

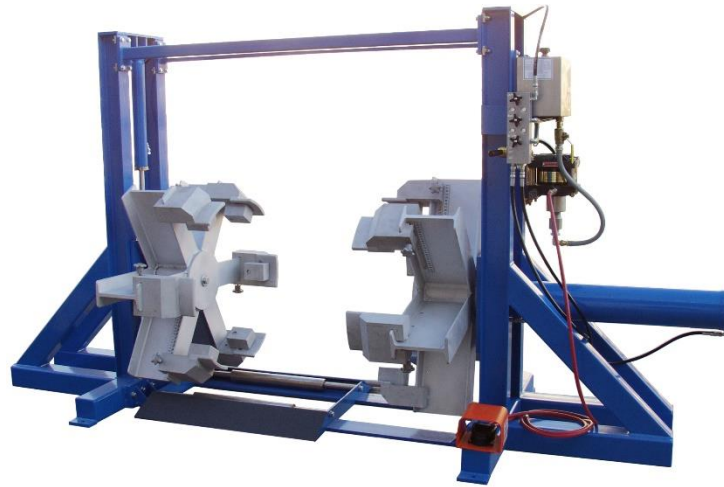

# OPERATION & SERVICE MANUAL



**Model: 14-6878-0110  
Hydraulic Beadbreaker**



01/2024 – Rev. 01

The Tronair Group of Companies: Tronair | DatcoMedia | Columbus Jack | Eagle | DAE | Malabar International

**Tronair, Inc.**  
1 Air Cargo Pkwy East  
Swanton, OH 43558

Phone: (419) 866-6301 | 800-426-6301  
Web: [www.tronair.com](http://www.tronair.com)  
Email: [sales@tronair.com](mailto:sales@tronair.com)

REVISION	DATE	TEXT AFFECTED
OR	01/2008	Original Release
01	01/2024	Major revision



**TABLE OF CONTENTS**

	<b><u>PAGE</u></b>
<b>1.0 PRODUCT INFORMATION .....</b>	<b>1</b>
1.1 DESCRIPTION.....	1
1.2 MODEL & SERIAL NUMBER.....	1
1.3 MANUFACTURER .....	1
1.4 TECHNICAL SPECIFICATIONS .....	1
<b>2.0 SAFETY INFORMATION .....</b>	<b>1</b>
2.1 USAGE AND SAFETY INFORMATION .....	1
<b>3.0 TRAINING .....</b>	<b>1</b>
3.1 TRAINING REQUIREMENTS .....	1
3.2 TRAINING PROGRAM .....	1
3.3 OPERATOR TRAINING .....	1
<b>4.0 PREPARATION FOR USE .....</b>	<b>2</b>
<b>5.0 OPERATION .....</b>	<b>3</b>
<b>6.0 MAINTENANCE .....</b>	<b>3</b>
<b>7.0 PROVISION OF SPARES .....</b>	<b>4</b>
7.1 SOURCE OF SPARE PARTS.....	4
7.2 RECOMMENDED SPARE PARTS LISTS .....	4
<b>8.0 GUARANTEES/LIMITATION OF LIABILITY .....</b>	<b>4</b>
<b>9.0 APPENDICES .....</b>	<b>4</b>



This product can not be modified without the written approval of Tronair, Inc. Any modifications done without written approval voids all warranties and releases Tronair, Inc., its suppliers, distributors, employees, or financial institutions from any liability from consequences that may occur. Only Tronair OEM replacement parts shall be used.

**1.0 PRODUCT INFORMATION**

**1.1 DESCRIPTION**

The Tronair Hydraulic Beadbreaker is an easy-to-use device for breaking the tire bead on rims 12-28 in (30-71 cm) diameter for tire sizes of 28-54 in (71-137 cm) diameter. An adapter kit, K-3151, may be purchased separately to allow for tires as small as 18 in (45.7 cm) diameter.

The tire beadbreaker uses a hydraulic cylinder driven by a pneumatic pump. The hydraulic controls are located in a manifold block and the cylinder operation is controlled through a foot-pedal pneumatic valve.

**1.2 MODEL & SERIAL NUMBER**

Reference nameplate on unit

**1.3 MANUFACTURER**

<b>TRONAIR</b> , Inc.	Telephone: (419) 866-6301 or 800-426-6301
1 Air Cargo Pkwy East	Fax: (419) 867-0634
Swanton, Ohio 43558 USA	E-mail: sales@tronair.com

**1.4 TECHNICAL SPECIFICATIONS**

Construction .....	All steel welded frame and members
Capacity - Rim sizes.....	12-28 in (30-71 cm) diameter
Maximum Working Pressure .....	1725 psi at 150 input air
Length .....	121 in (307 cm)
Width .....	40 in (102 cm)
Height.....	62.5 in (159)
Weight.....	1400 lbs (635 kg)

**2.0 SAFETY INFORMATION**

**2.1 USAGE AND SAFETY INFORMATION**

To ensure safe operations please read the following statements and understand their meaning. Also refer to your equipment manufacturer’s manual for other important safety information. This manual contains safety precautions which are explained below. Please read carefully.



**WARNING!**

Warning is used to indicate the presence of a hazard that can cause **severe personal injury, death, and/or substantial property damage** if the Warning Notice is ignored.



**CAUTION!**

Caution is used to indicate the presence of a hazard, which will or can cause **minor personal injury or property damage** if the Caution Notice is ignored.

**3.0 TRAINING**

**3.1 TRAINING REQUIREMENTS**

The employer of the operator is responsible for providing a training program sufficient for the safe operation of the unit.

**3.2 TRAINING PROGRAM**

The employer provided operator training program should cover safety procedures concerning use of the unit in and around the intended aircraft at the intended aircraft servicing location.

**3.3 OPERATOR TRAINING**

The operator training should provide the required training for safe operation of the unit.

**NOTE: Maintenance and Trouble Shooting are to be performed by a skilled and trained technician.**

**4.0 PREPARATION FOR USE**

1. Reference sections the Parts List Illustrations in this manual.
2. The hydraulic beadbreaker is shipped fully assembled and ready to use. Remove all packaging material and discard prior to use.
3. Secure to floor or sufficient fixturing using the  $\text{Ø}5/8$  mounting holes provided in 6 places as shown.

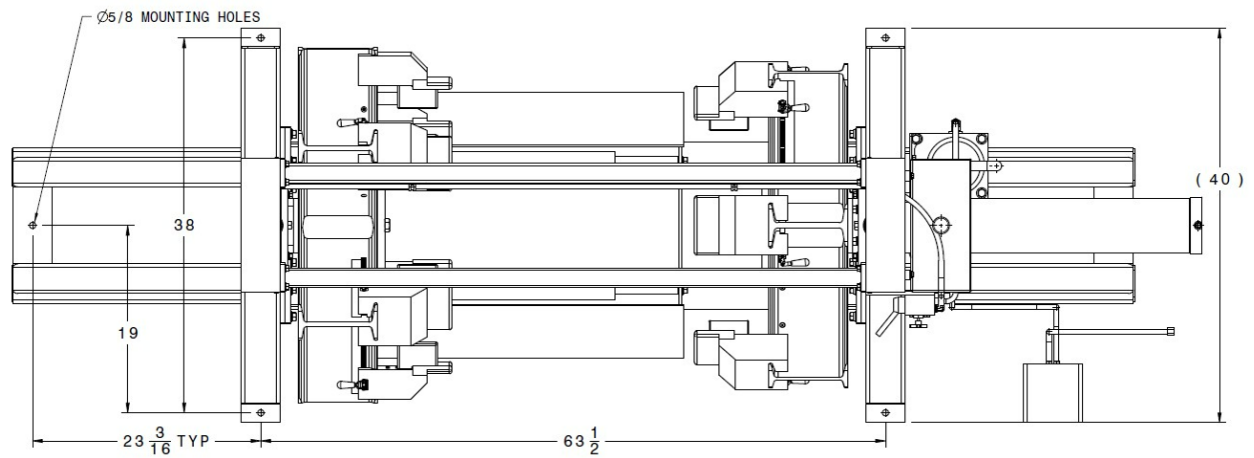

4. Check reservoir fluid level; fill as required. With all cylinders fully retracted, reservoir capacity is 2.5 gal (9.5 l). **Use MIL-PRF-5606 Hydraulic Fluid.**
5. Beadbreaker requires 80-150 psi (5.5-10.3 bar) shop air hook-up for operation.

## 5.0 OPERATION



### WARNINGS

- **ALWAYS follow the wheel manufacturer's instructions and procedures relative to their respective products.**
  - **Do Not attempt to disassemble wheel until tire has been completely deflated; otherwise, serious injury to personnel or damage to equipment may result.**
  - **Do Not attempt to remove valve core until tire has been completely deflated. Valve cores will be ejected at high velocity if unscrewed before air pressure has been released.**
1. Measure the outside tire rim diameter.
  2. Adjust the hydraulic beadbreaker fingers evenly from center, by positioning the inner face of the finger blocks to the rim diameter plus one (1) inch.
  3. Roll the tire into position on the beadbreaker rollers, getting it as close to the fixed side (side opposite the controls) as possible.
  4. Rotate the finger assembly on the fixed side; position one finger block vertically to aid in the positioning of the finger assembly height.
  5. Adjust the height of the fixed side finger assembly:
    - a. Lower the finger assembly by opening the control manifold valve labeled "Left" (uppermost). Slowly open the control manifold valve labeled "Return" (lower); close the "Return" valve when the inner face of the uppermost finger block is positioned about one-half inch above the wheel rim or centered around the rim. Once the finger assembly is positioned, close the "Left" valve.
    - b. Raise the finger assembly by opening the "Left" valve and stepping on the foot valve until the uppermost finger block is positioned about one-half inch above the wheel rim or centered around the rim. Once the finger assembly is positioned, close the "Left" valve.
  6. Adjust the height of the movable side (Control Side) finger assembly:
    - a. Lower the finger assembly by opening the control manifold valve labeled "Right" (Center) then slowly open the "Return" valve. Close the "Return" valve when the inner face of the uppermost finger block is positioned about one-half inch above the wheel rim or centered around the rim. Once the finger assembly is positioned, close the "Right" valve.
    - b. Raise the finger assembly by opening the "Right" valve and stepping on the foot valve until the uppermost finger block is positioned about one-half inch above the wheel rim or centered around the rim. Once the finger assembly is positioned, close the "Right" valve.
  7. Turn the control manifold selector valve to the "In" position. The pump airflow should be adjusted using the pneumatic valve on the pump so the cylinder is operating in a pulsing fashion.
  8. Step on the foot valve to bring the finger assemblies closer to the tire until there is slight contact between the tire and beadbreaker.
 

**Important: Check finger block positioning in relationship to the rim edge. Damage will occur to the wheel if the fingers come in contact with the rim.**
  9. If the finger assembly is not positioned correctly, re-position them before continuing.
  10. With the finger assembly correctly positioned, step on the foot valve. The cylinder will extend. Allow for both sides of the tire to break free from the wheel. Tires will normally break away from the wheel one side at a time; continue the beadbreaking process until both sides of the tire are free from the wheel.
  11. Turn the control manifold selector valve to the "Off" position. If the wheel has a locking ring, remove it at this time.
  12. To remove the tire and wheel from the beadbreaker, retract the cylinder by turning the control manifold selector valve to the "Out" position and stepping on the foot valve until the finger assembly has cleared the wheel. Turn the selector valve to the "Off" position and remove the wheel.

## 6.0 MAINTENANCE

1. Periodically perform a visual inspection of the beadbreaker assembly. Replace suspect parts as required.
2. Inspect mounting hardware, ensuring mounting is tight and unit is secure and stable.
3. Maintain hydraulic oil level in the pump reservoir.



## 7.0 PROVISION OF SPARES

### 7.1 SOURCE OF SPARE PARTS

Spare parts may be obtained from the manufacturer:

<b>TRONAIR</b> , Inc.	Telephone: (419) 866-6301 or 800-426-6301
1 Air Cargo Pkwy East	Fax: (419) 867-0634
Swanton, Ohio 43558 USA	E-mail: sales@tronair.com
	Website: www.tronair.com

For Spare Parts, Operations & Service Manuals or Service Needs:  
Scan the QR code or visit [Tronair.com/aftermarket](http://Tronair.com/aftermarket)

### 7.2 RECOMMENDED SPARE PARTS LISTS

Reference the following page(s) for Replacement Parts and Kits available.

## 8.0 GUARANTEES/LIMITATION OF LIABILITY

Tronair products are warranted to be free of manufacturing or material defects for a period of one year after shipment to the original customer. This is solely limited to the repair or replacement of defective components. This warranty does not cover the following items:

- Parts required for normal maintenance
- Parts covered by a component manufacturers warranty
- Replacement parts have a 90-day warranty from date of shipment

If you have a problem that may require service, contact Tronair immediately. Do not attempt to repair or disassemble a product without first contacting Tronair, any action may affect warranty coverage. When you contact Tronair be prepared to provide the following information:

- Product Model Number
- Product Serial Number
- Description of the problem

If warranty coverage is approved, either replacement parts will be sent or the product will have to be returned to Tronair for repairs. If the product is to be returned, a Return Material Authorization (RMA) number will be issued for reference purposes on any shipping documents. Failure to obtain a RMA in advance of returning an item will result in a service fee. A decision on the extent of warranty coverage on returned products is reserved pending inspection at Tronair. Any shipments to Tronair must be shipped freight prepaid. Freight costs on shipments to customers will be paid by Tronair on any warranty claims only. Any unauthorized modification of the Tronair products or use of the Tronair products in violation of cautions and warnings in any manual (including updates) or safety bulletins published or delivered by Tronair will immediately void any warranty, express or implied.

The obligations of Tronair expressly stated herein are in lieu of all other warranties or conditions expressed or implied. **Any unauthorized modification of the Tronair products or use of the Tronair products in violations of cautions and warnings in any manual (including updates) or safety bulletins published or delivered by Tronair will immediately void any warranty, express or implied and Tronair disclaims any and all liability for injury (WITHOUT LIMITATION and including DEATH), loss or damage arising from or relating to such misuse.**

## 9.0 APPENDICES

APPENDIX I SDS – MIL-PRF-5606 Hydraulic Fluid  
APPENDIX II Haskel Air Pump  
APPENDIX III Declaration of Conformity

### Parts List

When ordering replacement parts/kits, please specify model, serial number and color of your unit.

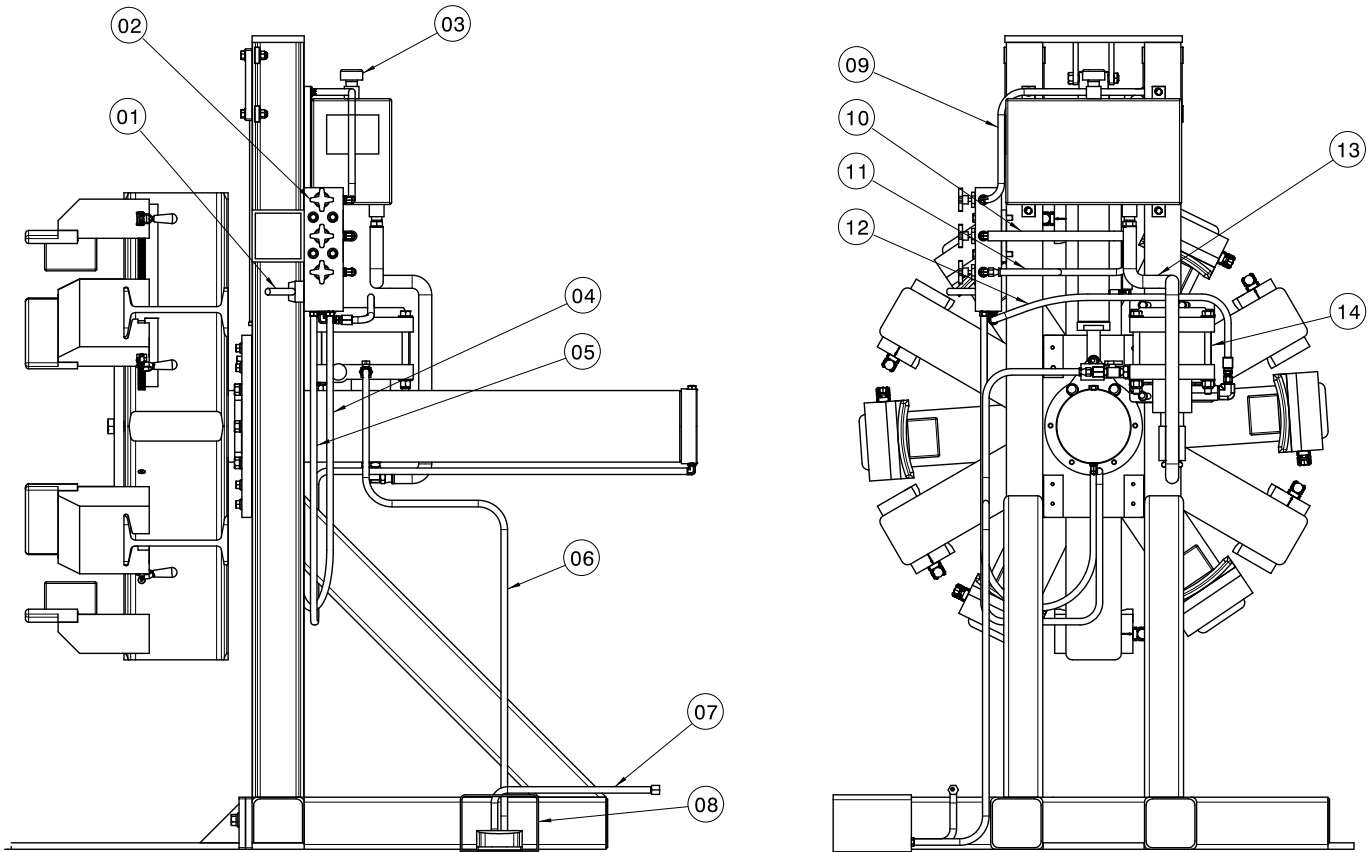

Item	Part Number	Description	Qty
1	HC-1837	VALVE, DIRECTIONAL CONTROL	1
2	HC-1716	VALVE, CARTRIDGE NEEDLE	3
3	H-1045	BREATHER	1
4	TF-1043-01*45.0	ASSEMBLY, HOSE	1
5	TF-1043-01*60.0	ASSEMBLY, HOSE	1
6	TF-1047-02*96.0	HOSE, PUSH-ON	1
7	TF-1047-02*36.0	HOSE, PUSH-ON	1
8	Z-4385	ASSEMBLY, FOOT PEDAL (includes Items 6 & 7)	1
9	TF-1043-01*105	ASSEMBLY, HOSE	1
10	TF-1043-01*18.0	ASSEMBLY, HOSE	1
11	TF-1047-01*12.0	HOSE, PUSH-ON	1
12	TF-1043-01*24.0	ASSEMBLY, HOSE	1
13	TF-1047-05*25.0	HOSE, PUSH-ON	1
14	PC-1083	AIR PUMP	1
N/S	17571-10	LIQUID SECTION SEAL KIT	1
N/S	16772	AIR DRIVE SEAL KIT	1
N/S	16771	AIR VALVE SEAL KIT	1

### Parts List

When ordering replacement parts/kits, please specify model, serial number and color of your unit.

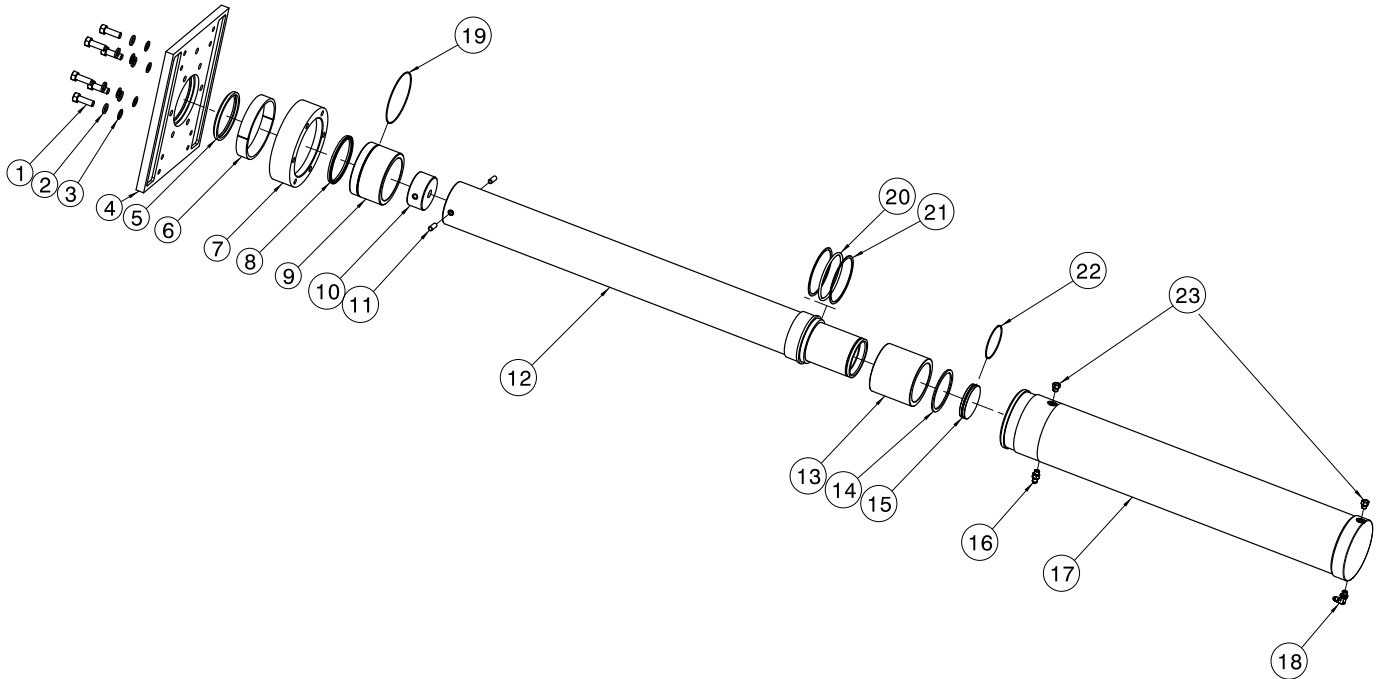

Item	Part Number	Description	Qty
1	G-1420-109520	BOLT, HH GR 8, 1/2 - 20 X 2 LG	6
2	G-1251-1090R	LOCKWASHER, 1/2 REGULAR	6
3	G-1255-09	WASHER, 1/2 AN	6
4	J-4133-01	PLATE, CYLINDER	1
5	HC-1619-4000D	WIPER, RING	1
6	TR-1678	RING, LOCKING	1
7	R-2312-01	SUPPORT, CYLINDER	1
8	HC-1621-212	SEAL, POLYPAK	1
9	TR-1989	RING, GUIDE	1
10	R-2309	PLUG, FRONT RAM	1
11	G-1300-38100	PIN, ROLL 3/8 X 1	2
12	TR-1987	TUBE, RAM	1
13	TR-1988	BUSHING, RAM	1
14	G-1395-57	RING, EXTERNAL	1
15	R-2310	PLUG, REAR RAM	1
16	N-2007-03-S-B	CONNECTOR, STR THD (-04 X -04)	1
17	Z-6636-01	WELDMENT, MAIN CYLINDER	1
18	N-2001-03-S-B	ELBOW, STR THD (-04 X -04)	1
19	HC-2000-048	O-RING SERIES 2	1
20	HC-2000-346	O-RING SERIES 2	1
21	HC-2023-346	RING, BACK-UP, ONE PIECE	2
22	HC-2000-041	O-RING SERIES 2	1
23	N-2053-03-S-B	PLUG, HH STR THD (-04)	2

**Parts List**

When ordering replacement parts/kits, please specify model, serial number and color of your unit.

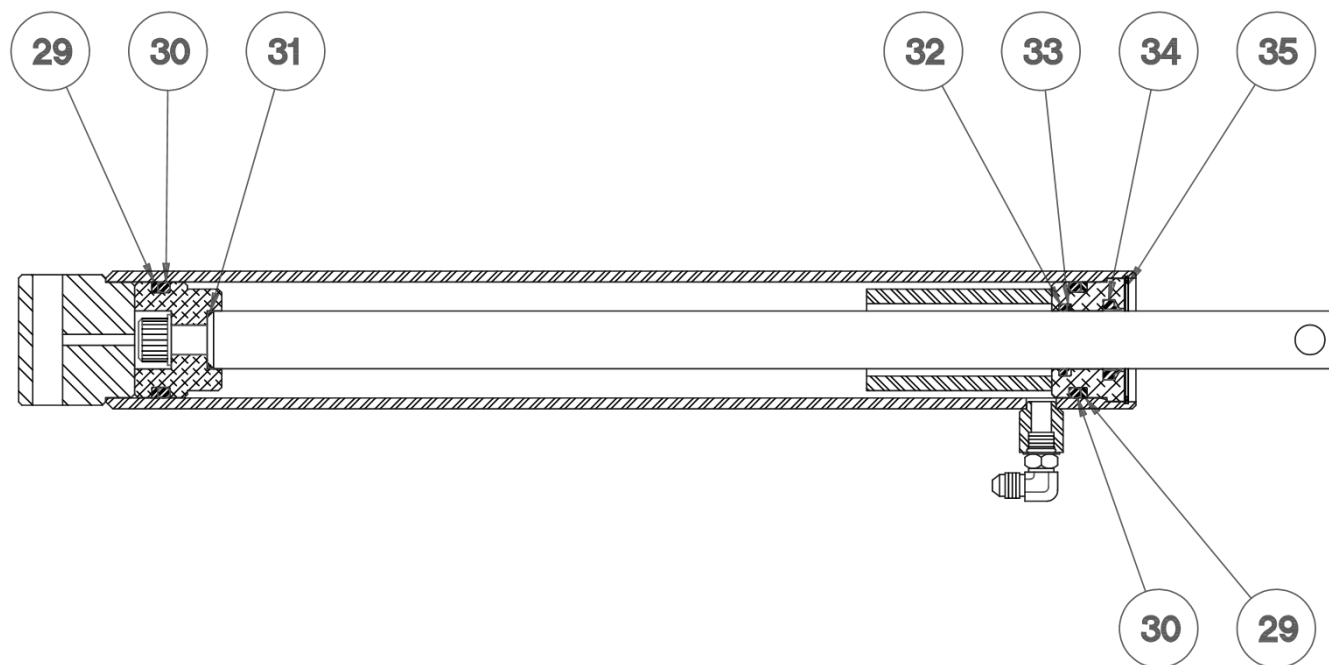

Item	Part Number	Description	Qty
	<b>K-3143</b>	<b>KIT, CYLINDER SEAL REPLACEMENT; consists of:</b>	
29	HC-2020-326	RING, BACKUP	2
30	HC-2000-326	O-RING	2
31	HC-2000-117	O-RING	1
32	HC-2000-214	O-RING	1
33	HC-2020-214	RING, BACKUP	1
34	HC-1655-09	RING, WIPER	1
35	G-1398-212	RING, RETAINING	1
	<b>K-3151</b>	<b>KIT, SMALL TIRE ADAPTER; consists of:</b>	
N/S	V-1001	LABEL, "MADE IN USA"	1
N/S	V-1197-02	LABEL, "TRONAIR"	1
N/S	Z-4524	ASSEMBLY, SMALL TIRE ADAPTER; CONSISTS OF:	
N/S	Z-4523-01	WELDMENT, SMALL TIRE ADAPTER	1
N/S	G-1100-109512	BOLT, ½--20 HEX HEAD GRADE 5	4
N/S	G-1250-1090N	FLATWASHER, ½ NARROW	4
N/S	G-1251-1090R	LOCKWASHER, ½ REGULAR	4
N/S	H-1884	BEARING, ROLLER	4
N/S	R-1971	ROD, ROLLER	2
N/S	TR-1702	TUBE, ROLLER	2

### Parts List

When ordering replacement parts/kits, please specify model, serial number and color of your unit.

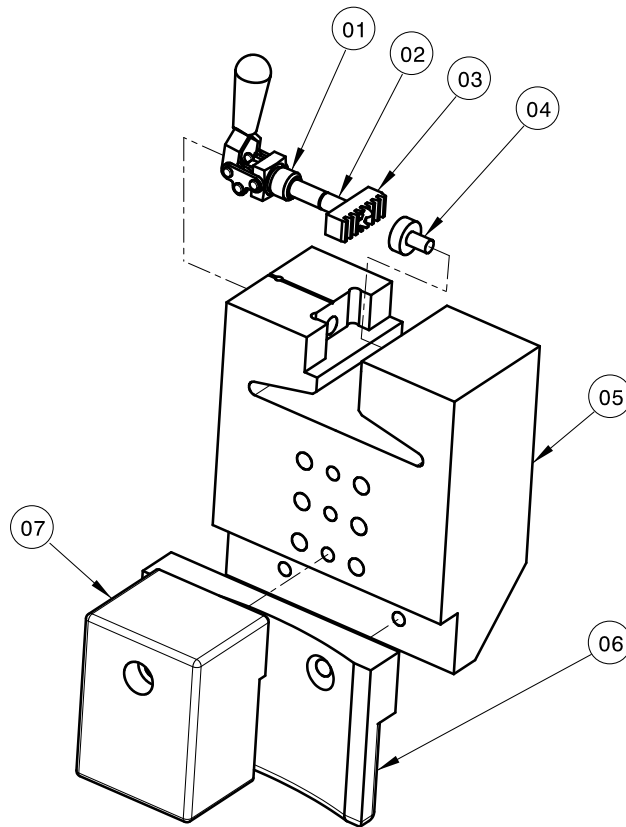

Item	Part Number	Description	Qty
1	H-3094	Clamp, Toggle	1
2	TR375-05*000.58	Spacer	1
3	J-4236	Gear, Lock	1
4	R-1818	Plug, Stop	1
5	J-4134	Block, Slide	1
6	J-2978	Finger, Top	1
7	J-2977	Block, Stop	1





## **APPENDIX I**

**Safety Data Sheet (SDS)  
MIL-PRF-5606  
Hydraulic Fluid**





Product Name: MOBIL AERO HFA  
Revision Date: 01 Oct 2015  
Page 1 of 12

## SAFETY DATA SHEET

### SECTION 1 PRODUCT AND COMPANY IDENTIFICATION

#### PRODUCT

**Product Name:** MOBIL AERO HFA  
**Product Description:** Base Oil and Additives  
**Product Code:** 201550401020, 490110-00, 970584  
**Intended Use:** Aviation hydraulic oil

#### COMPANY IDENTIFICATION

**Supplier:** EXXON MOBIL CORPORATION  
22777 Springwoods Village Parkway  
Spring, TX. 77253 USA  
**24 Hour Health Emergency** 609-737-4411  
**Transportation Emergency Phone** 800-424-9300 or 703-527-3887 CHEMTREC  
**Product Technical Information** 800-662-4525  
**MSDS Internet Address** <http://www.exxon.com>, <http://www.mobil.com>

### SECTION 2 HAZARDS IDENTIFICATION

This material is hazardous according to regulatory guidelines (see (M)SDS Section 15).

#### CLASSIFICATION:

Flammable liquid: Category 4.  
Aspiration toxicant: Category 1.

#### LABEL:

Pictogram:



**Signal Word:** Danger

#### Hazard Statements:

H227: Combustible liquid. H304: May be fatal if swallowed and enters airways.

#### Precautionary Statements:

P210: Keep away from flames and hot surfaces. -- No smoking. P273: Avoid release to the environment. P280: Wear protective gloves and eye / face protection. P301 + P310: IF SWALLOWED: Immediately call a POISON CENTER or doctor/physician. P331: Do NOT induce vomiting. P370 + P378: In case of fire: Use water fog, foam, dry chemical or carbon dioxide (CO2) to extinguish. P403 + P235: Store in a well-ventilated place. Keep cool. P405: Store locked up. P501: Dispose of contents and container in accordance with local regulations.



Product Name: MOBIL AERO HFA  
 Revision Date: 01 Oct 2015  
 Page 2 of 12

**Other hazard information:**

**HAZARD NOT OTHERWISE CLASSIFIED (HNOC):** None as defined under 29 CFR 1910.1200.

**PHYSICAL / CHEMICAL HAZARDS**

Material can accumulate static charges which may cause an ignition. Material can release vapors that readily form flammable mixtures. Vapor accumulation could flash and/or explode if ignited. Combustible.

**HEALTH HAZARDS**

High-pressure injection under skin may cause serious damage. Excessive exposure may result in eye, skin, or respiratory irritation.

**ENVIRONMENTAL HAZARDS**

No significant hazards.

**NFPA Hazard ID:** Health: 1 Flammability: 2 Reactivity: 0  
**HMIS Hazard ID:** Health: 1\* Flammability: 2 Reactivity: 0

**NOTE:** This material should not be used for any other purpose than the intended use in Section 1 without expert advice. Health studies have shown that chemical exposure may cause potential human health risks which may vary from person to person.

**SECTION 3 COMPOSITION / INFORMATION ON INGREDIENTS**

This material is defined as a mixture.

**Hazardous Substance(s) or Complex Substance(s) required for disclosure**

Name	CAS#	Concentration*	GHS Hazard Codes
2,6-DI-TERT-BUTYL-P-CRESOL	128-37-0	0.1 - < 1%	H400(M factor 1), H410(M factor 1)
DISTILLATES (PETROLEUM), HYDROTREATED LIGHT	64742-47-8	5 - < 10%	H304
HYDROTREATED LIGHT NAPHTHENIC DISTILLATE (PETROLEUM)	64742-53-6	50 - < 70%	H227, H304
HYDROTREATED MIDDLE DISTILLATE (PETROLEUM)	64742-46-7	20 - < 30%	H304
TRIPHENYL PHOSPHATE	115-86-6	0.1 - < 0.25%	H400(M factor 1), H410(M factor 1)

\* All concentrations are percent by weight unless material is a gas. Gas concentrations are in percent by volume.

As per paragraph (i) of 29 CFR 1910.1200, formulation is considered a trade secret and specific chemical identity and exact percentage (concentration) of composition may have been withheld. Specific chemical identity and exact percentage composition will be provided to health professionals, employees, or designated representatives in accordance with applicable provisions of paragraph (i).

**SECTION 4 FIRST AID MEASURES**

**INHALATION**



Product Name: MOBIL AERO HFA  
Revision Date: 01 Oct 2015  
Page 3 of 12

Remove from further exposure. For those providing assistance, avoid exposure to yourself or others. Use adequate respiratory protection. If respiratory irritation, dizziness, nausea, or unconsciousness occurs, seek immediate medical assistance. If breathing has stopped, assist ventilation with a mechanical device or use mouth-to-mouth resuscitation.

#### SKIN CONTACT

Wash contact areas with soap and water. Remove contaminated clothing. Launder contaminated clothing before reuse. If product is injected into or under the skin, or into any part of the body, regardless of the appearance of the wound or its size, the individual should be evaluated immediately by a physician as a surgical emergency. Even though initial symptoms from high pressure injection may be minimal or absent, early surgical treatment within the first few hours may significantly reduce the ultimate extent of injury.

#### EYE CONTACT

Flush thoroughly with water. If irritation occurs, get medical assistance.

#### INGESTION

Seek immediate medical attention. Do not induce vomiting.

#### NOTE TO PHYSICIAN

If ingested, material may be aspirated into the lungs and cause chemical pneumonitis. Treat appropriately.

### SECTION 5 FIRE FIGHTING MEASURES

#### EXTINGUISHING MEDIA

**Appropriate Extinguishing Media:** Use water fog, foam, dry chemical or carbon dioxide (CO<sub>2</sub>) to extinguish flames.

**Inappropriate Extinguishing Media:** Straight Streams of Water

#### FIRE FIGHTING

**Fire Fighting Instructions:** Evacuate area. Prevent runoff from fire control or dilution from entering streams, sewers, or drinking water supply. Firefighters should use standard protective equipment and in enclosed spaces, self-contained breathing apparatus (SCBA). Use water spray to cool fire exposed surfaces and to protect personnel.

**Unusual Fire Hazards:** Combustible. Pressurized mists may form a flammable mixture.

**Hazardous Combustion Products:** Aldehydes, Incomplete combustion products, Oxides of carbon, Phosphorus oxides, Smoke, Fume, Sulfur oxides

#### FLAMMABILITY PROPERTIES

**Flash Point [Method]:** >82°C (180°F) [ASTM D-93]

**Flammable Limits (Approximate volume % in air):** LEL: 0.7 UEL: 7.0 [Estimated]

**Autoignition Temperature:** >225°C (437°F)

### SECTION 6 ACCIDENTAL RELEASE MEASURES

#### NOTIFICATION PROCEDURES

In the event of a spill or accidental release, notify relevant authorities in accordance with all applicable



Product Name: MOBIL AERO HFA  
Revision Date: 01 Oct 2015  
Page 4 of 12

regulations. US regulations require reporting releases of this material to the environment which exceed the applicable reportable quantity or oil spills which could reach any waterway including intermittent dry creeks. The National Response Center can be reached at (800)424-8802.

#### PROTECTIVE MEASURES

Avoid contact with spilled material. Warn or evacuate occupants in surrounding and downwind areas if required due to toxicity or flammability of the material. See Section 5 for fire fighting information. See the Hazard Identification Section for Significant Hazards. See Section 4 for First Aid Advice. See Section 8 for advice on the minimum requirements for personal protective equipment. Additional protective measures may be necessary, depending on the specific circumstances and/or the expert judgment of the emergency responders.

For emergency responders: Respiratory protection: respiratory protection will be necessary only in special cases, e.g., formation of mists. Half-face or full-face respirator with filter(s) for dust/organic vapor or Self Contained Breathing Apparatus (SCBA) can be used depending on the size of spill and potential level of exposure. If the exposure cannot be completely characterized or an oxygen deficient atmosphere is possible or anticipated, SCBA is recommended. Work gloves that are resistant to hydrocarbons are recommended. Gloves made of polyvinyl acetate (PVA) are not water-resistant and are not suitable for emergency use. Chemical goggles are recommended if splashes or contact with eyes is possible. Small spills: normal antistatic work clothes are usually adequate. Large spills: full body suit of chemical resistant, antistatic material is recommended.

#### SPILL MANAGEMENT

**Land Spill:** Eliminate all ignition sources (no smoking, flares, sparks or flames in immediate area). Stop leak if you can do it without risk. All equipment used when handling the product must be grounded. Do not touch or walk through spilled material. Prevent entry into waterways, sewer, basements or confined areas. A vapor suppressing foam may be used to reduce vapors. Use clean non-sparking tools to collect absorbed material. Absorb or cover with dry earth, sand or other non-combustible material and transfer to containers. Large Spills: Water spray may reduce vapor; but may not prevent ignition in closed spaces. Recover by pumping or with suitable absorbent.

**Water Spill:** Stop leak if you can do it without risk. Confine the spill immediately with booms. Warn other shipping. Remove from the surface by skimming or with suitable absorbents. Seek the advice of a specialist before using dispersants.

Water spill and land spill recommendations are based on the most likely spill scenario for this material; however, geographic conditions, wind, temperature, (and in the case of a water spill) wave and current direction and speed may greatly influence the appropriate action to be taken. For this reason, local experts should be consulted. Note: Local regulations may prescribe or limit action to be taken.

#### ENVIRONMENTAL PRECAUTIONS

Large Spills: Dike far ahead of liquid spill for later recovery and disposal. Prevent entry into waterways, sewers, basements or confined areas.

<b>SECTION 7</b>	<b>HANDLING AND STORAGE</b>
------------------	-----------------------------

#### HANDLING

Avoid contact with skin. Avoid prolonged breathing of mists and heated vapor. Prevent small spills and leakage to avoid slip hazard. Material can accumulate static charges which may cause an electrical spark (ignition source). When the material is handled in bulk, an electrical spark could ignite any flammable vapors from liquids or residues that may be present (e.g., during switch-loading operations). Use proper bonding and/or ground procedures. However, bonding and grounds may not eliminate the hazard from static



Product Name: MOBIL AERO HFA

Revision Date: 01 Oct 2015

Page 5 of 12

accumulation. Consult local applicable standards for guidance. Additional references include American Petroleum Institute 2003 (Protection Against Ignitions Arising out of Static, Lightning and Stray Currents) or National Fire Protection Agency 77 (Recommended Practice on Static Electricity) or CENELEC CLC/TR 50404 (Electrostatics - Code of practice for the avoidance of hazards due to static electricity).

**Static Accumulator:** This material is a static accumulator.

## STORAGE

The container choice, for example storage vessel, may effect static accumulation and dissipation. Keep container closed. Handle containers with care. Open slowly in order to control possible pressure release. Store in a cool, well-ventilated area. Storage containers should be grounded and bonded. Fixed storage containers, transfer containers and associated equipment should be grounded and bonded to prevent accumulation of static charge.

## SECTION 8 EXPOSURE CONTROLS / PERSONAL PROTECTION

### EXPOSURE LIMIT VALUES

Exposure limits/standards (Note: Exposure limits are not additive)

Substance Name	Form	Limit / Standard		NOTE	Source
2,6-DI-TERT-BUTYL-P-CRESOL	Inhalable fraction and vapor	TWA	2 mg/m <sup>3</sup>	N/A	ACGIH
DISTILLATES (PETROLEUM), HYDROTREATED LIGHT [total hydrocarbon vapor]	Non-Aerosol	TWA	200 mg/m <sup>3</sup>	Skin	ACGIH
HYDROTREATED LIGHT NAPHTHENIC DISTILLATE (PETROLEUM)	Mist.	TWA	5 mg/m <sup>3</sup>	N/A	OSHA Z1
HYDROTREATED LIGHT NAPHTHENIC DISTILLATE (PETROLEUM)	Inhalable fraction.	TWA	5 mg/m <sup>3</sup>	N/A	ACGIH
HYDROTREATED LIGHT NAPHTHENIC DISTILLATE (PETROLEUM)	Mist.	TWA	5 mg/m <sup>3</sup>	N/A	ACGIH
HYDROTREATED MIDDLE DISTILLATE (PETROLEUM)	Mist.	TWA	5 mg/m <sup>3</sup>	N/A	OSHA Z1
HYDROTREATED MIDDLE DISTILLATE (PETROLEUM)	Inhalable fraction.	TWA	5 mg/m <sup>3</sup>	N/A	ACGIH
TRIPHENYL PHOSPHATE		TWA	3 mg/m <sup>3</sup>	N/A	OSHA Z1
TRIPHENYL PHOSPHATE		TWA	3 mg/m <sup>3</sup>	N/A	ACGIH

**Exposure limits/standards for materials that can be formed when handling this product:** When mists/aerosols can occur the following are recommended: 5 mg/m<sup>3</sup> - ACGIH TLV (inhalable fraction), 5 mg/m<sup>3</sup> - OSHA PEL.

NOTE: Limits/standards shown for guidance only. Follow applicable regulations.

No biological limits allocated.

### ENGINEERING CONTROLS

The level of protection and types of controls necessary will vary depending upon potential exposure conditions.



Product Name: MOBIL AERO HFA  
Revision Date: 01 Oct 2015  
Page 6 of 12

---

Control measures to consider:  
Use explosion-proof ventilation equipment to stay below exposure limits.

## PERSONAL PROTECTION

Personal protective equipment selections vary based on potential exposure conditions such as applications, handling practices, concentration and ventilation. Information on the selection of protective equipment for use with this material, as provided below, is based upon intended, normal usage.

**Respiratory Protection:** If engineering controls do not maintain airborne contaminant concentrations at a level which is adequate to protect worker health, an approved respirator may be appropriate. Respirator selection, use, and maintenance must be in accordance with regulatory requirements, if applicable. Types of respirators to be considered for this material include:

No special requirements under ordinary conditions of use and with adequate ventilation.

For high airborne concentrations, use an approved supplied-air respirator, operated in positive pressure mode. Supplied air respirators with an escape bottle may be appropriate when oxygen levels are inadequate, gas/vapor warning properties are poor, or if air purifying filter capacity/rating may be exceeded.

**Hand Protection:** Any specific glove information provided is based on published literature and glove manufacturer data. Glove suitability and breakthrough time will differ depending on the specific use conditions. Contact the glove manufacturer for specific advice on glove selection and breakthrough times for your use conditions. Inspect and replace worn or damaged gloves. The types of gloves to be considered for this material include:

If prolonged or repeated contact is likely, chemical resistant gloves are recommended. If contact with forearms is likely, wear gauntlet style gloves.

**Eye Protection:** If contact is likely, safety glasses with side shields are recommended.

**Skin and Body Protection:** Any specific clothing information provided is based on published literature or manufacturer data. The types of clothing to be considered for this material include:

If prolonged or repeated contact is likely, chemical, and oil resistant clothing is recommended.

**Specific Hygiene Measures:** Always observe good personal hygiene measures, such as washing after handling the material and before eating, drinking, and/or smoking. Routinely wash work clothing and protective equipment to remove contaminants. Discard contaminated clothing and footwear that cannot be cleaned. Practice good housekeeping.

## ENVIRONMENTAL CONTROLS

Comply with applicable environmental regulations limiting discharge to air, water and soil. Protect the environment by applying appropriate control measures to prevent or limit emissions.

<b>SECTION 9</b>	<b>PHYSICAL AND CHEMICAL PROPERTIES</b>
------------------	---

**Note:** Physical and chemical properties are provided for safety, health and environmental considerations only and may not fully represent product specifications. Contact the Supplier for additional information.

## GENERAL INFORMATION

**Physical State:** Liquid  
**Color:** Red



Product Name: MOBIL AERO HFA  
 Revision Date: 01 Oct 2015  
 Page 7 of 12

**Odor:** Characteristic  
**Odor Threshold:** N/D

#### IMPORTANT HEALTH, SAFETY, AND ENVIRONMENTAL INFORMATION

**Relative Density (at 15 °C):** 0.88  
**Flammability (Solid, Gas):** N/A  
**Flash Point [Method]:** >82°C (180°F) [ASTM D-93]  
**Flammable Limits (Approximate volume % in air):** LEL: 0.7 UEL: 7.0 [Estimated]  
**Autoignition Temperature:** >225°C (437°F)  
**Boiling Point / Range:** N/D  
**Decomposition Temperature:** N/D  
**Vapor Density (Air = 1):** N/D  
**Vapor Pressure:** [N/D at 20 °C]  
**Evaporation Rate (n-butyl acetate = 1):** N/D  
**pH:** N/A  
**Log Pow (n-Octanol/Water Partition Coefficient):** N/D  
**Solubility in Water:** Negligible  
**Viscosity:** 13.8 cSt (13.8 mm<sup>2</sup>/sec) at 40 °C | 5.1 cSt (5.1 mm<sup>2</sup>/sec) at 100°C [ASTM D 445]  
**Oxidizing Properties:** See Hazards Identification Section.

#### OTHER INFORMATION

**Freezing Point:** N/D  
**Melting Point:** N/A  
**Pour Point:** -60°C (-76°F) [ASTM D97]  
**DMSO Extract (mineral oil only), IP-346:** < 3 %wt

### SECTION 10 STABILITY AND REACTIVITY

**REACTIVITY:** See sub-sections below.

**STABILITY:** Material is stable under normal conditions.

**CONDITIONS TO AVOID:** Open flames and high energy ignition sources.

**MATERIALS TO AVOID:** Strong oxidizers

**HAZARDOUS DECOMPOSITION PRODUCTS:** Material does not decompose at ambient temperatures.

**POSSIBILITY OF HAZARDOUS REACTIONS:** Hazardous polymerization will not occur.

### SECTION 11 TOXICOLOGICAL INFORMATION

#### INFORMATION ON TOXICOLOGICAL EFFECTS

Hazard Class	Conclusion / Remarks
<b>Inhalation</b>	
Acute Toxicity: No end point data for material.	Minimally Toxic. Based on assessment of the components.
Irritation: No end point data for material.	Elevated temperatures or mechanical action may form vapors, mist, or fumes which may be irritating to the eyes, nose, throat, or lungs.



Product Name: MOBIL AERO HFA

Revision Date: 01 Oct 2015

Page 8 of 12

<b>Ingestion</b>	
Acute Toxicity: No end point data for material.	Minimally Toxic. Based on assessment of the components.
<b>Skin</b>	
Acute Toxicity: No end point data for material.	Minimally Toxic. Based on assessment of the components.
Skin Corrosion/Irritation: No end point data for material.	May dry the skin leading to discomfort and dermatitis. Based on assessment of the components.
<b>Eye</b>	
Serious Eye Damage/Irritation: No end point data for material.	May cause mild, short-lasting discomfort to eyes. Based on assessment of the components.
<b>Sensitization</b>	
Respiratory Sensitization: No end point data for material.	Not expected to be a respiratory sensitizer.
Skin Sensitization: No end point data for material.	Not expected to be a skin sensitizer. Based on assessment of the components.
<b>Aspiration:</b> Data available.	May be fatal if swallowed and enters airways. Based on physico-chemical properties of the material.
<b>Germ Cell Mutagenicity:</b> No end point data for material.	Not expected to be a germ cell mutagen. Based on assessment of the components.
<b>Carcinogenicity:</b> No end point data for material.	Not expected to cause cancer. Based on assessment of the components.
<b>Reproductive Toxicity:</b> No end point data for material.	Not expected to be a reproductive toxicant. Based on assessment of the components.
<b>Lactation:</b> No end point data for material.	Not expected to cause harm to breast-fed children.
<b>Specific Target Organ Toxicity (STOT)</b>	
Single Exposure: No end point data for material.	Not expected to cause organ damage from a single exposure.
Repeated Exposure: No end point data for material.	Not expected to cause organ damage from prolonged or repeated exposure. Based on assessment of the components.

#### TOXICITY FOR SUBSTANCES

NAME	ACUTE TOXICITY
2,6-DI-TERT-BUTYL-P-CRESOL	Oral Lethality: LD50 0.89 g/kg (Rat)

#### OTHER INFORMATION

##### For the product itself:

Repeated and/or prolonged exposure may cause irritation to the skin, eyes, or respiratory tract. Small amounts of liquid aspirated into the lungs during ingestion or from vomiting may cause chemical pneumonitis or pulmonary edema.

##### Contains:

Base oil severely refined: Not carcinogenic in animal studies. Representative material passes IP-346, Modified Ames test, and/or other screening tests. Dermal and inhalation studies showed minimal effects; lung non-specific infiltration of immune cells, oil deposition and minimal granuloma formation. Not sensitizing in test animals.

The following ingredients are cited on the lists below: None.

--REGULATORY LISTS SEARCHED--



Product Name: MOBIL AERO HFA  
Revision Date: 01 Oct 2015  
Page 9 of 12

1 = NTP CARC  
2 = NTP SUS

3 = IARC 1  
4 = IARC 2A

5 = IARC 2B  
6 = OSHA CARC

## SECTION 12 ECOLOGICAL INFORMATION

The information given is based on data available for the material, the components of the material, and similar materials.

### ECOTOXICITY

Material -- Not expected to be harmful to aquatic organisms.

### MOBILITY

More volatile component -- Highly volatile, will partition rapidly to air. Not expected to partition to sediment and wastewater solids.

Less volatile component -- Low solubility and floats and is expected to migrate from water to the land. Expected to partition to sediment and wastewater solids.

### PERSISTENCE AND DEGRADABILITY

#### Biodegradation:

Components -- Expected to be inherently biodegradable

### BIOACCUMULATION POTENTIAL

Majority of components -- Has the potential to bioaccumulate, however metabolism or physical properties may reduce the bioconcentration or limit bioavailability.

## SECTION 13 DISPOSAL CONSIDERATIONS

Disposal recommendations based on material as supplied. Disposal must be in accordance with current applicable laws and regulations, and material characteristics at time of disposal.

### DISPOSAL RECOMMENDATIONS

Product is suitable for burning in an enclosed controlled burner for fuel value or disposal by supervised incineration at very high temperatures to prevent formation of undesirable combustion products. Protect the environment. Dispose of used oil at designated sites. Minimize skin contact. Do not mix used oils with solvents, brake fluids or coolants.

### REGULATORY DISPOSAL INFORMATION

RCRA Information: The unused product, in our opinion, is not specifically listed by the EPA as a hazardous waste (40 CFR, Part 261D), nor is it formulated to contain materials which are listed as hazardous wastes. It does not exhibit the hazardous characteristics of ignitability, corrosivity or reactivity and is not formulated with contaminants as determined by the Toxicity Characteristic Leaching Procedure (TCLP). However, used product may be regulated.

**Empty Container Warning** Empty Container Warning (where applicable): Empty containers may contain residue and can be dangerous. Do not attempt to refill or clean containers without proper instructions. Empty drums should be



Product Name: MOBIL AERO HFA  
Revision Date: 01 Oct 2015  
Page 10 of 12

completely drained and safely stored until appropriately reconditioned or disposed. Empty containers should be taken for recycling, recovery, or disposal through suitably qualified or licensed contractor and in accordance with governmental regulations. DO NOT PRESSURISE, CUT, WELD, BRAZE, SOLDER, DRILL, GRIND, OR EXPOSE SUCH CONTAINERS TO HEAT, FLAME, SPARKS, STATIC ELECTRICITY, OR OTHER SOURCES OF IGNITION. THEY MAY EXPLODE AND CAUSE INJURY OR DEATH.

<b>SECTION 14</b>	<b>TRANSPORT INFORMATION</b>
-------------------	------------------------------

**LAND (DOT)**

**Proper Shipping Name:** COMBUSTIBLE LIQUID, N.O.S. (Distillates (Petroleum), Hydrotreated Light)  
**Hazard Class & Division:** COMBUSTIBLE LIQUID  
**ID Number:** NA1993  
**Packing Group:** III  
**ERG Number:** 128  
**Label(s):** NONE  
**Transport Document Name:** NA1993, COMBUSTIBLE LIQUID, N.O.S. (Distillates (Petroleum), Hydrotreated Light), COMBUSTIBLE LIQUID, PG III

Footnote: This material is not regulated under 49 CFR in a container of 119 gallon capacity or less when transported solely by land, as long as the material is not a hazardous waste, a marine pollutant, or specifically listed as a hazardous substance.

**LAND (TDG):** Not Regulated for Land Transport

**SEA (IMDG):** Not Regulated for Sea Transport according to IMDG-Code

**Marine Pollutant:** No

**AIR (IATA):** Not Regulated for Air Transport

<b>SECTION 15</b>	<b>REGULATORY INFORMATION</b>
-------------------	-------------------------------

**OSHA HAZARD COMMUNICATION STANDARD:** This material is considered hazardous in accordance with OSHA HazCom 2012, 29 CFR 1910.1200.

**Listed or exempt from listing/notification on the following chemical inventories:** AICS, DSL, ENCS, IECSC, KECI, PICCS, TCSI, TSCA

**EPCRA SECTION 302:** This material contains no extremely hazardous substances.

**SARA (311/312) REPORTABLE HAZARD CATEGORIES:** Fire. Immediate Health. Delayed Health.

**SARA (313) TOXIC RELEASE INVENTORY:** This material contains no chemicals subject to the supplier notification requirements of the SARA 313 Toxic Release Program.



Product Name: MOBIL AERO HFA

Revision Date: 01 Oct 2015

Page 11 of 12

The following ingredients are cited on the lists below:

Chemical Name	CAS Number	List Citations
DISTILLATES (PETROLEUM), HYDROTREATED LIGHT	64742-47-8	1, 17, 18
HYDROTREATED LIGHT NAPHTHENIC DISTILLATE (PETROLEUM)	64742-53-6	1, 4, 13, 17, 18
HYDROTREATED MIDDLE DISTILLATE (PETROLEUM)	64742-46-7	1, 4, 17, 18

## --REGULATORY LISTS SEARCHED--

1 = ACGIH ALL	6 = TSCA 5a2	11 = CA P65 REPRO	16 = MN RTK
2 = ACGIH A1	7 = TSCA 5e	12 = CA RTK	17 = NJ RTK
3 = ACGIH A2	8 = TSCA 6	13 = IL RTK	18 = PA RTK
4 = OSHA Z	9 = TSCA 12b	14 = LA RTK	19 = RI RTK
5 = TSCA 4	10 = CA P65 CARC	15 = MI 293	

Code key: CARC=Carcinogen; REPRO=Reproductive

SECTION 16	OTHER INFORMATION
------------	-------------------

N/D = Not determined, N/A = Not applicable

**KEY TO THE H-CODES CONTAINED IN SECTION 3 OF THIS DOCUMENT (for information only):**

H227: Combustible liquid; Flammable Liquid, Cat 4

H304: May be fatal if swallowed and enters airways; Aspiration, Cat 1

H400: Very toxic to aquatic life; Acute Env Tox, Cat 1

H410: Very toxic to aquatic life with long lasting effects; Chronic Env Tox, Cat 1

**THIS SAFETY DATA SHEET CONTAINS THE FOLLOWING REVISIONS:**

Revision Changes:

Section 01: Company Mailing Address information was modified.

Section 05: Hazardous Combustion Products information was modified.

Section 15: List Citations Table information was modified.

Section 15: National Chemical Inventory Listing information was modified.

Section 14: Marine Pollutant information was modified.

Composition: Component Table information was modified.

Section 08: Exposure Limits Table information was modified.

Section 16: Revision Information - Implementation of GHS requirements phrase. information was deleted.

-----

The information and recommendations contained herein are, to the best of ExxonMobil's knowledge and belief, accurate and reliable as of the date issued. You can contact ExxonMobil to insure that this document is the most current available from ExxonMobil. The information and recommendations are offered for the user's consideration and examination. It is the user's responsibility to satisfy itself that the product is suitable for the intended use. If buyer repackages this product, it is the user's responsibility to insure proper health, safety and other necessary information is included with and/or on the container. Appropriate warnings and safe-handling procedures should be provided to handlers and users. Alteration of this document is strictly prohibited. Except to the extent required by law,



Product Name: MOBIL AERO HFA  
Revision Date: 01 Oct 2015  
Page 12 of 12

---

re-publication or retransmission of this document, in whole or in part, is not permitted. The term, "ExxonMobil" is used for convenience, and may include any one or more of ExxonMobil Chemical Company, Exxon Mobil Corporation, or any affiliates in which they directly or indirectly hold any interest.

---

Internal Use Only

MHC: 2A, 0, 0, 0, 1, 1

PPEC: C

DGN: 2005454XUS (552975)

---

Copyright 2002 Exxon Mobil Corporation, All rights reserved



## **APPENDIX II**

### **Haskel Air Pump Technical Specifications & Performance Data**



**Haskel**  
an Accudyne Industries brand

Pressure on Demand

*Pneumatic Driven Liquid Pumps*





## High Pressure

Haskel pneumatic driven liquid pumps are designed to provide a safe, reliable and economical, source of hydraulic pressure.

This brochure introduces our pneumatic driven liquid pump range. Visit our website at [www.haskel.com](http://www.haskel.com) for more information or to locate a distributor.

## Why Use Haskel Pneumatic Driven Pumps?

*Our pumps offer many advantages over electrically driven pumps:*

- Safe pneumatic operation – no heat, flame or spark risk
- Up to 100,000 psi (7000 bar) capability
- Infinitely variable cycling speed
- Stall feature at pre-determined pressure to hold that pressure without consuming power
- Problem-free stop/start applications
- Easily automated – many modification and control options
- Suitable for most liquids and liquefied gases
- Alternative gas drive options – sour gas, natural gas, boil off gases, nitrogen
- No need for air line lubrication – saves costs and prevents contamination
- Robust, reliable, compact and easy to maintain proven design
- Unbalanced cycling spool provides immediate response to pressure changes
- Also available in standard, or custom built power pac configurations
- Excellent worldwide service for spares and repairs
- ATEX approved
- CE certified

## Applications include:

- Pressure testing
- Work holding/power clamping
- Jacking/lifting
- Valve actuator control
- Hydraulic cylinder actuation
- Press safety overload devices
- Roller tensioning
- Metering
- Precision lubrication and spraying
- Liquefied gas transfer

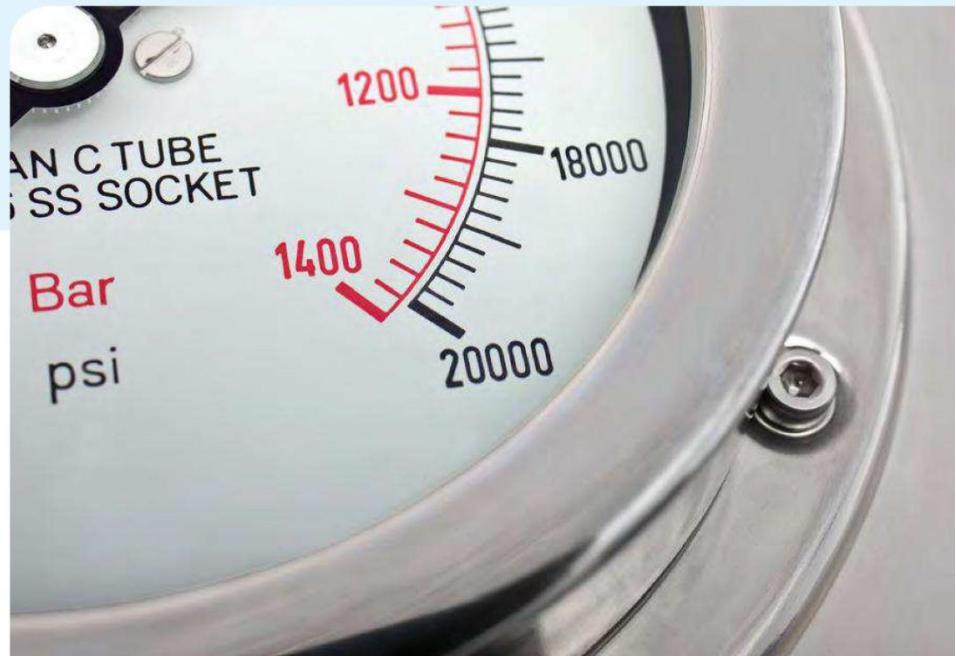

## Pressure and Flow on Demand

This guide will help you to pre-select the pump ideally suited for your application. If you have specific questions, however, we urge you to provide Haskel with the operational details of your application. We will recommend a model and any corresponding accessories.

## Output Horsepower Ratings

The pumps are categorized on their horsepower ratings (see pages 6-7). These are approximate and peak at 100 psi (7 bar), assuming adequate drive, pressure and volume. Peak horsepower is at about 75% nominal ratio x drive pressure, i.e. 100:1 pump @ 100 psi air drive peaks at  $100 \times 100 = 10000 \times 0.75$  psi = 7500 psi (517 bar) hydraulic pressure.

## Operation

The pumps automatically reciprocate on a differential piston principle. A large piston driven by relatively low pressure drive acts directly upon a smaller hydraulic piston.

The nominal ratio between piston sizes is indicated in the model coding and approximates to the maximum working pressure. The actual ratio is about 15% above nominal so that the pump continues to cycle when drive pressure equals nominal ratio. Initially, the pump will cycle at maximum speed acting as a transfer pump to pressurize downstream.

It will cycle at a slower rate as the fluid meets resistance until it stalls at maximum output pressure. When a pressure drop downstream occurs, it will recycle as necessary in an effort to maintain maximum pressure. Stall pressure is achieved when the outlet pressure rises and offers more resistance to the reciprocating differential piston assembly. The piston assembly then stalls when the forces balance, e.g. when drive pressure x drive piston area equals outlet (stall) pressure x driven hydraulic plunger area. The pump design is sensitive to very small pressure drops due to the low frictional resistance of the large diameter drive piston and hydraulic piston seals.

## Double and Triple Air Head Pumps

Performance can be extended for the 1.5 hp pumps by stacking air pistons without changing the hydraulic piston. Haskel multi-head pumps consume less air than competitive single head pumps of the same area, as only one head is pressurized on the return stroke; e.g., on a 1.5 hp pump additional heads can raise performance to 2 hp.

Double air head pumps are identified by the last digit 2 in the pump model number. Thus, a nominal 50:1 ratio pump with two air heads is described as a 52. Similarly, a triple air head pump is identified with a last digit 3. Thus, a 900 ratio pump with three air heads is described as a 903.

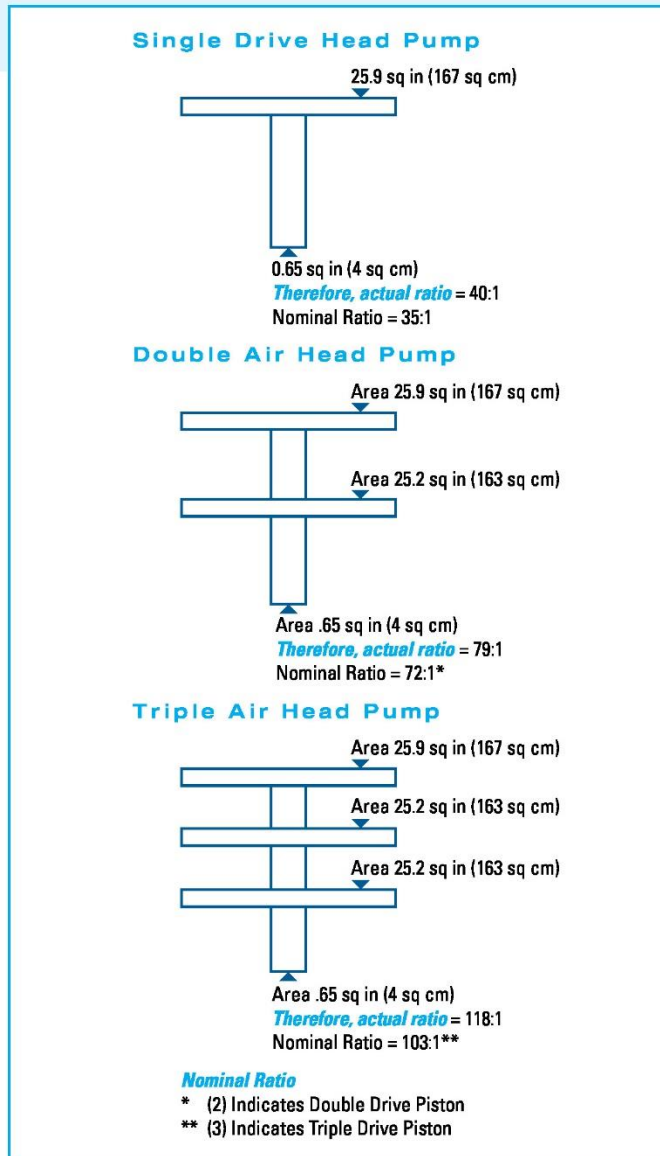

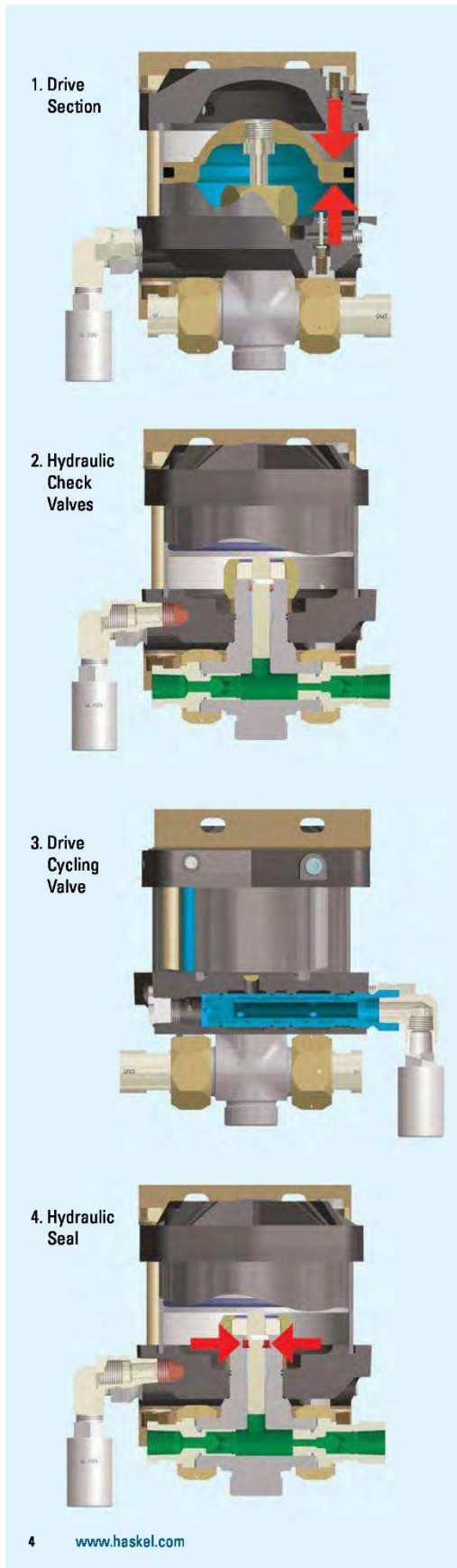

## Anatomy of a Pneumatic Driven Pump

### 1. Drive Section

The piston, complete with "O" ring seal, operates in an epoxy filled, fiberglass wound barrel, the diameter of which is constant throughout a given series of pumps. Drive media forces the piston down on the compression stroke and raises it on the suction stroke (M series have a spring return). The piston is pre-lubricated during assembly and therefore no air line lubricator is necessary.

### 2. Hydraulic Section/Check Valves

The drive piston is linked and connected to the hydraulic plunger/piston in the hydraulic section. Outlet flow and pressure are determined by the area of the hydraulic piston head, its nominal ratio with the drive piston head, and drive pressure. On the down stroke, liquid in the hydraulic section is forced under compression through the outlet check valve. Fresh liquid is induced via the inlet check valve on the return stroke. These check valves control the flow of liquid through the hydraulic section. They are spring-loaded and have a very low cracking pressure, allowing maximum opening on the induction stroke. The pressure of hydraulic fluid on the down stroke closes the inlet check valve and acts against the spring to open the outlet check valve.

### 3. Drive Cycling Valve

This is a pilot-operated, unbalanced, lightweight spool, which directs drive pressure, first to the top of the drive piston, and then to the underside to reciprocate the piston (cycle). It actuates via pilot valves at the top and the bottom of the stroke, which causes the unbalanced spool to shift and reciprocate the piston.

### 4. Hydraulic Seal/Check Valves

This is one of the few wear parts. Its function is to allow the hydraulic piston to reciprocate without passing fluid into the drive section. The liquid, its pressure and its temperature determine seal specification. A distance piece can be incorporated between drive and hydraulic sections for complete contamination-free operation on most Haskel pumps.



## WETTED MATERIALS OF CONSTRUCTION AND SERVICES

	MODEL	SERVICES (refer to pg. 17)	WETTED MATERIALS		NON METALLICS
			PUMP SECTION	PLUNGERS	
.33 hp	<b>M</b>	1	Cad plated steel, Aluminum & SS	416 SS	Urethane, PTFE, Buna
	<b>MS</b>	1, 2	All SS	316 SS	UHMWPE, PTFE, Buna
	<b>297Z3</b>	1, 2, 3, 5, 6	Separation - All SS	Hard Chrome Plated 15.5PH SS + Dichronite	UHMWPE, PTFE, Ryton
	<b>MDSTV</b>	1, 2, 3, 4, 5, 6	Stainless Steel and Aluminum	303 Stainless Steel	Viton, PTFE
.75hp	<b>4B-14 thru -37</b>	1, 2	Aluminum	Aluminum(Hard coated)	UHMWPE, Buna
	<b>4B-55 thru -100</b>	1, 2	303 SS	440 C. SS	UHMWPE, Buna
1.5 hp	<b>AW</b>	1	Nickel Plated Steel & SS	440C SS	Urethane, Buna N, PTFE
	<b>ASF</b>	1, 2	All SS	440C SS	UHMWPE, Buna, PTFE, Ryton
	<b>DSF</b>	1, 2, 3, 5, 6	Separation - All SS	440C SS Hard Chrome Plated	UHMWPE, Viton, PTFE, Ryton
	<b>HF</b>	1	Nickel Plated Steel & SS	Stellite 15-5PH SS	UHMWPE, Buna N
	<b>HSF</b>	1, 2	All SS	Stellite 15-5PH SS	UHMWPE, Buna N
	<b>DSHF</b>	1, 2, 5, 6	Separation - All SS	Stellite 15-5PH SS	UHMWPE, Buna N
	<b>ATV</b>	1, 2	Aluminum, Bronze & SS	15.5PH SS	PTFE, Viton
	<b>DTV</b>	1, 2, 5	Separation - Aluminum, Bronze & SS	15.5PH SS	PTFE, Viton
	<b>DSTV-1.5</b>	1, 2, 3, 4, 5, 6	Separation - All SS	17.4PH SS	PTFE, Viton
	<b>DSTV</b>	1, 2, 3, 4, 5	Separation - All SS	440C SS Hard Chrome Plated	PTFE, Viton
	<b>DTN</b>	1, 2, 5	Stainless Steel, Aluminum	300 Series SS	Neopreen, PTFE
2 thru 3hp	<b>AW</b>	1	Nickel Plated Steel & SS	440C SS	Urethane, Buna N, PTFE
	<b>AFD</b>	1	Nickel Plated Steel & SS	416 SS	UHMWPE, Buna, PTFE, Ryton
	<b>DFD</b>	1, 3, 5	Nickel Plated Steel & SS	416 SS	UHMWPE, Viton, PTFE, Ryton
	<b>ASFD</b>	1, 2	All SS	15.5PH SS	UHMWPE, Viton, PTFE, Ryton
	<b>ASF</b>	1, 2	All SS	440C SS	UHMWPE, Viton, PTFE, Ryton
	<b>DSFD</b>	1, 2, 3, 5, 6	Separation - All SS	15.5PH SS	UHMWPE, Viton, PTFE, Ryton
	<b>DSF</b>	1, 2, 3, 5, 6	Separation - All SS	440C SS Hard chrome plated	UHMWPE, Viton, PTFE, Ryton
	<b>HF</b>	1	Nickel Plated Steel & SS	Stellite 15-5PH SS*	UHMWPE, Buna N
	<b>HSF</b>	1, 2	All SS	Stellite 15-5PH SS*	UHMWPE, Buna N
	<b>DSHF</b>	1, 2, 5, 6	Separation - All SS	Stellite 15-5PH SS*	UHMWPE, Buna N
	<b>DSXHF</b>	1, 2, 5, 6	Separation - All SS	Stellite 15-5PH SS	UHMWPE, Buna N
	<b>DSXHW</b>	1, 2	Separation - All SS	Stellite 15-5PH SS	Urethane, PTFE
	<b>DSTV-1.5</b>	1, 2, 3, 4, 5, 6	Separation - All SS	17.4PH SS	PTFE, Viton
	<b>DSTV</b>	1, 2, 3, 4, 5	Separation - All SS	440C SS Hard chrome plated	PTFE, Viton
	<b>*Except -202 ratio is chrome plated 440 SS</b>				
6 hp	<b>GW</b>	1	Nickel Plated Steel, SS & Bronze	Hard chrome plated 15.5PH SS	Urethane, Buna N, PTFE
	<b>GSF</b>	1, 2	All SS & Bronze	Hard chrome plated 15.5PH SS	UHMWPE, Viton, PTFE, Ryton
	<b>DGSF</b>	1, 2, 3, 5, 6	Separation- All SS & Bronze	Hard chrome plated 15.5PH SS	UHMWPE, Viton, PTFE, Ryton
	<b>DGSTV</b>	1, 2, 3, 4, 5	Separation- All SS & Bronze	Hard chrome plated 15.5PH SS	Viton, PTFE, Ryton
	<b>GWD</b>	1	Nickel Plated Steel & SS	15.5PH SS Hard chrome plate optional	Urethane, Buna N, PTFE
	<b>GSFD</b>	1, 2	All SS & Bronze	15.5PH SS Hard chrome plate optional	UHMWPE, Buena N, PTFE, Ryton
	<b>DGFD</b>	1, 3, 5	Separation- Nickel Plated Steel & SS	15.5PH SS hard chrome plate optional	UHMWPE, Viton, PTFE, Ryton
	<b>DGSFD</b>	1, 2, 3, 4, 5, 6	Separation- All SS & Bronze	15.5PH SS Hard chrome plate optional	UHMWPE, Viton, PTFE, Ryton
	<b>DGSTVD</b>	1, 2, 3, 4, 5	Separation- All SS & Bronze	17.4PH SS Hard chrome plate optional	PTFE, Viton
8 hp	<b>8SFD</b>	1, 2	All SS & Bronze*	Hard chrome plated 15.5PH SS	UHMWPE, Viton, PTFE, Ryton
	<b>8DSFD</b>	1, 2, 3, 5, 6	Separation- All SS & Bronze	15.5PH SS Hard chrome	UHMWPE, Viton, PTFE, Ryton
	<b>8DSTD</b>	1, 2, 3, 4, 5, 6	Separation- All SS & Bronze	15.5PH SS Hard chrome	PTFE, Viton
	<b>8HSFD</b>	1, 2	All SS & Bronze*	17.4PH SS	UHMWPE, Viton, PTFE, Ryton
	<b>8DSTVD</b>	1, 2, 3, 5, 6	All SS & Bronze*	15-5 PH SS Hard chrome	Viton, PTFE
	<b>8SFD2</b>	1, 2, 6	All SS & Bronze*	15-5 PH SS Hard chrome	PTFE, Viton, UHMWPE
10 hp	<b>D14STD-125</b>	1, 2, 3, 4, 5A	All SS & Bronze	Hard chrome plated 440C SS	PTFE, Viton
	<b>D14STD-315</b>	1, 2, 3, 4, 5A	All SS & Bronze	Hard chrome plated 440C SS	PTFE, Viton
	<b>D14SFD-125</b>	1, 2, 3, 5A, 6	All SS & Bronze	Tungston Carbide Coated 15.5PH SS	UHMWPE, Viton, PTFE, Ryton
	<b>D14SFD-315</b>	1, 2, 3, 5A, 6	All SS & Bronze	Tungston Carbide Coated 15.5PH SS	UHMWPE, Viton, PTFE, Ryton

### Performance and Specification Overview

Max Air Air Head Power	Pump Model Code	Ratio Dash no.	Actual Area Ratio	Maximum Rated Output Pressure				Displacement/Cycle		Maximum Flow		
				Continuous		Intermittent		cu in	ml	cu in/min	l/min	
				psi	bar	psi	bar					
125 psi/8.6 bar Single 0.33 hp	M, MDSTV	-5	5.6	625	43	625	43	0.83	13.6	506	8.30	
	M, MS	-7	7.8	900	62	900	62	0.60	9.8	366	6.00	
	M, MS, 29723	-12	14	1500	103	1500	103	0.36	5.9	234	3.83	
		-21	25	2600	179	2600	179	0.20	3.3	130	2.13	
		-36	41	4500	310	4500	310	0.12	2.0	78	1.28	
	M, MS	-71	82	8800	607	8800	607	0.06	1.0	39	0.64	
		-110	126	13500	931	13500	931	0.039	0.60	25	0.42	
		-188	217	15000	1034	15000	1034	0.023	0.40	18	0.29	
29723	-188	217	10000	1034	10000	1034	0.023	0.40	18	0.29		
MS	-220	220	20000	1380	25000	1723	0.021	0.34	14	0.22		
100 psi/7 bar Single 0.75 hp	4B	-14	16	1500	103	1500	103	0.9	14.7	428	7.01	
		-30	34	3200	221	3200	221	0.43	7.0	204	3.35	
		-37	42	3800	262	3800	262	0.35	5.7	166	2.72	
		-55	63	6000	414	6000	414	0.22	3.6	105	1.71	
		-100	114	10600	731	10600	731	0.13	2.0	62	1.01	
150 psi/10.5 bar Single 1.5 hp	DSTV	-1.5	1.6	240	17	300	21	31.90	513	5104	83.6	
	ATV, DTN, DTV	-4	4.6	690	48	1200	83	20.00	328	3200	52.4	
	AW, ASF, DSF, DSTV	-B10	11.5	1600	110	1600	110	4.05	66.4	1215	19.9	
		-B15	17	2400	165	2400	165	2.70	44.3	810	13.3	
		-25	29	4000	276	4000	276	1.62	26.6	486	8.0	
		-35	40	5700	393	5700	393	1.16	19.0	348	5.7	
		-60	69	9800	676	9800	676	0.67	11.0	201	3.3	
		-100	115	15000	1034	16500	1138	0.41	6.7	123	2.0	
	HF, HSF, DSHF	-150	173	15000	1034	20000	1379	0.27	4.5	81	1.3	
		-151	173	25000	1724	25000	1724	0.27	4.5	81	1.3	
		-225	260	30000	2069	37000	2552	0.18	3.0	41	0.7	
	HF	-300	345	30000	2069	50000	3448	0.14	2.3	32	0.5	
		-450	533	45000	3103	45000	3103	0.0	1.5	20	0.3	
	150 psi/10.5 bar Double 2 hp	ATV	-8	9.2	850	59	1200	83	20	328	3200	52.4
AW, ASF, DSF, DSTV		-B22	23	3200	221	3200	221	4.05	66.4	1215	19.9	
		-B32	34	4800	331	4800	331	2.70	44.3	810	13.3	
		-52	57	5000	345	8000	552	1.62	26.6	488	8.0	
		-72	80	11000	759	11000	759	1.16	19.0	348	5.7	
HF, HSF, DSHF		-122	138	15000	1034	19000	1310	0.67	11.0	201	3.3	
		-202	230	30000	2069	33000	2276	0.41	6.7	92	1.5	
DSXHF		-302	346	30000	2069	50000	3448	0.27	4.5	61	1.0	
		-452	520	30000	2069	70000	4828	0.18	3.0	41	0.7	
-602		690	30000	2069	75000	5172	0.14	2.3	32	0.5		
100 psi/7 bar Triple 2 hp	DXHF, DSXHF	-683	780	30000	2069	70000	4828	0.18	3.0	25	0.41	
	DSXHW	-903	1038	30000	2069	75000	5172	0.14	2.3	20	0.33	
		-1373	1575	30000	2069	100000	6897	0.086	1.4	12	0.197	
2.2	AFD-DFD-ASF-DSFD	-B80	69	6500	448	6500	448	1.34	2.2	369	6.0	
150 psi/10.5 bar 3 hp	ASFD	-10	11.5	1600	110	1600	110	8.10	133	1823	29.9	
		-15	17	2400	165	2400	165	5.40	89	1215	19.9	
		-25	29	4000	276	4000	276	3.24	53.6	729	11.9	
		-35	40	5700	393	5700	393	2.32	38.0	522	8.6	
		-60	69	9800	676	9800	676	1.34	22.0	302	4.9	
		-100	115	15000	1034	16500	1138	0.82	13.4	185	3.0	
		-150	173	15000	1034	20000	1379	0.54	9.0	122	2.0	
		-202	230	30000	2069	33000	2276	0.62	13.4	144	2.4	
125 psi/8.6 bar Single 6 hp	GWD, GSFD, DGSFD, DGSTVD	-12	14.8	1850	128	4000	276	15.9	260	5009	82.1	
	GW, GSF, DGSF, DGSTV	-35	40.3	4375	302	4375	302	6.0	98	1890	31.0	
		-60	69	7500	517	7500	517	3.5	57	1103	18.1	
		-100	115	8000	552	10000	690	2.1	34	662	10.8	
125 psi/8.6 bar 8 hp	8SFD, 8DSFD, 8DSTVD	-25	27.5	3575	246	4000	276	14.0	229	2660	43.5	
		-40	43.5	6000	414	6000	414	8.90	145	1691	28.0	
		-65	73	10000	690	10000	690	5.40	88	1026	17.0	
		-100	112	10000	690	10000	690	3.52	58	669	11.0	
		8HSFD	-225	253	25000	1724	25000	1724	1.56	26	296	5.0
		8SFD2 (Double Air Drive Piston Models)	-55	55	5500	379	7200	497	14.14	232	1900	31.1
			-88	88	8800	607	10000	690	8.84	145	1182	19.36
-224	225	25000	1724	25000	1724	3.53	58	476	7.6			
10 hp	D14STD, D14SFD	-125	138	18000	1103	18000	1103	8.80	144.2	704	11.5	
		-315	347	36000	2483	36000	2483	3.50	57.4	280	4.6	

Typical Performance using 100 psi (7 bar) Air drive							
Outlet Pressure		Outlet Flow		Outlet Pressure		Outlet Flow	
psi	bar	cu in/min	l/min	psi	bar	cu in/min	l/min
225	15.5	500	8.20	415	29	249	4.09
300	21	350	5.70	600	41	160	2.6
700	48	200	3.28	1125	78	100	1.64
1500	103	90	1.48	2000	138	48.9	0.8
1700	117	70	1.15	3100	214	39.6	0.65
2450	169	tbd	tbd	4500	310	tbd	tbd
3000	207	40	0.64	6000	414	19	0.31
7500	517	20	0.33	10000	690	8.5	0.14
5000	345	18	0.30	10000	690	14	0.23
5000	345	18	0.30	10000	690	14	0.23
7500	517	15	0.24	15000	1034	12	0.2
700	48	400	6.55	1450	100	61	1.00
1500	103	200	3.28	3000	207	62	1.00
1750	121	170	2.78	3500	241	82	1.33
2000	138	110	1.80	5000	345	66	1.08
5000	345	57	0.93	10000	690	26	0.43
50	3	5000	81.9	150	10	1000	16.4
100	7	1953	32	400	28	750	12.3
400	28	1000	16.4	900	68	500	8.19
750	52	598	9.8	1600	110	200	3.28
1000	69	403	6.6	2500	172	195	3.2
2000	138	350	4.1	3600	248	98	1.6
3000	207	152	2.5	6200	427	50	0.82
4000	276	100	1.64	10000	690	24.4	0.4
7000	483	59.7	0.98	15000	1034	29.9	0.49
7000	483	59.7	0.98	15000	1034	29.9	0.49
7500	517	39.6	0.65	24000	1655	9.8	0.16
15000	1034	29.9	0.49	27000	1862	20.1	0.33
36000	2483	14.6	0.24	45000	3103	9.2	0.15
200	14	1953	32	800	28	750	12.3
400	28	799	13.1	2100	145	200	3.28
700	48	500	8.2	3000	207	152	2.50
1900	131	299	4.9	5000	345	98	1.60
2000	138	226	3.7	7500	517	50	0.82
4000	276	122	2.0	12000	828	40.2	0.66
7000	483	91.5	1.5	20000	1379	20.1	0.33
10000	690	45.2	0.7	30000	2069	15.2	0.25
10000	690	34.8	0.6	40000	2759	15.2	0.25
15000	1034	24.4	0.4	50000	3448	12.2	0.2
15000	1034	19.5	0.32	60000	4138	4.9	0.08
15000	1034	15.9	0.26	70000	4828	5.5	0.09
16000	1103	9.2	0.15	90000	6207	3.1	0.05
1000	69	348	5.7	5500	379	152	2.5
500	34	1520	24.9	1000	69	380	6.22
750	52	1030	16.9	1500	103	260	4.26
1000	69	662	10.9	2500	172	162	2.66
1500	1034	465	7.6	3500	248	100	1.64
3000	138	248	4.1	6000	414	56	0.92
5000	345	151	2.5	10000	690	41	0.67
7500	517	103	2.0	15000	1034	27	0.44
10000	690	63	1.0	20000	1379	47	0.77
200	14	5004	82	1200	83	1454	24
1000	69	1770	29	3500	241	600	9.8
2000	138	976	16	5500	379	397	6.5
2000	138	573	9.4	10000	690	195	3.2
1000	69	2400	39.3	2500	172	280	4.6
2000	138	1420	23.2	4000	276	200	3.27
3000	207	880	14.4	6000	414	310	5.08
5000	345	555	9.1	10000	690	163	2.67
10000	690	270	4.4	20000	1379	144	2.36
2500	172	1230	20.1	4000	276	675	11
4000	276	850	13.9	5000	345	800	13.1
10000	690	315	5.2	18500	1276	140	2.3
8000	552	488	8.0	12000	828	195	3.2
15000	1034	238	3.9	30000	2069	79.3	1.3

## Pump Selection Information

All Haskel pumps are identified by letters coding the type of pump, followed by a number indicating the practical working ratio of the drive area to the hydraulic plunger area. These letters are explained in the chart below.

### Pump Model Letter Coding

<b>M</b>	.875" stroke .33 hp miniature pump series
<b>S</b>	Stainless steel hydraulic piston and body
<b>29723</b>	.33 hp Chemical Pump
<b>D (Prefix)</b>	Pump incorporates a Distance Piece
<b>D (Suffix)</b>	Double Acting pump
<b>4B</b>	1" stroke .75 hp pump series (bottom inlet only)
<b>A</b>	2" stroke 1.5 + 2 hp pump series
<b>H</b>	2" stroke 1.5 + 2 hp High Pressure pump series
<b>XH</b>	2" stroke 1.5 + 2 hp Extreme High Pressure pump series
<b>G</b>	4.5" stroke 6 hp pump series
<b>B</b>	4.5" stroke 8 hp pump or booster series
<b>14</b>	4" stroke 10 hp pump series
<b>W</b>	Polyurethane U-cup dynamic seal
<b>F</b>	UHMWPE (Ultra-high Molecular Weight Polyethylene Dynamic Seal
<b>T</b>	Reinforced Teflon® dynamic seal
<b>V</b>	Viton® o-ring static seal



## Guidelines for 24/7 Continuous Duty Applications for Maximizing Seal Life Performance

Pump Series	Maximum Cycles per Minute
0.3 hp	90 cpm
0.75 hp	80 cpm
1.5, 2.0 and 2.2 hp (Single and Double Drive Piston)	60 cpm
2.0 hp (Triple Drive Piston)	60 cpm
3.0 hp	60 cpm
6.0 hp	40 cpm
8.0 hp	40 cpm
10.0 hp	40 cpm

## .33 hp (.25 kW) M Series Pump Models



### Key Features

- Choice of 6 models, 9 ratios, 27 possible combinations
- Flows to 2 gpm (7.5 l/min)
- Choice of wetted materials
- Single air head
- Drive pressure 25 to 125 psi (1.8 to 9 bar)
- Pressures to 25,000 psi (1724 bar)
- All Hydraulic fluids, water (plain or DI), solvents, mild chemicals, liquefied gases

### Optional Modifications

Number	Description
-HP	Hand pump attachment (with handle). Provides manual operation of pump for precision pressure control or use without air power
26220-2	Hand pump attachment kit.
29002	Viton air drive.
51331	EPR seals for liquid section for 29723-XX ratio pumps.
51788	Piped exhaust – standard. Provides connection ports for drive and pilot exhausts. Enables under tank top mounting and/or natural gas drive.
51794	Piped exhaust – sour gas. With hand pump (HP).
51794-2	Piped exhaust – sour gas. Without hand pump (HP).
53175	Level II cleaning.
53304	High pressure outlet port. Fits 1/4" O.D. high pressure threaded and coned tube.
53935	Low temperature drive. Enables operation down to 5°F. Some sacrifice of seal life at normal temperature. M or MS series.
57905	No return spring. Provides improved fill on suction stroke pumping liquefied gases by utilizing the inlet pressure. Only available on M and MS series.
59888	Cycle timer installed.
80103	Noise reduction kit fitted.
82367	SS trim for 1/3 hp drive

Model	Nominal Ratio	Maximum Working Pressure <small>Consult chart on page 6 for more information regarding continuous/intermittent pressures.</small>	Displacement per Cycle
M, MDSTV	-5	625 psi (43 bar)	.83 cu in (13.6 ml)
M, MS	-7	900 psi (62 bar)	.6 cu in (9.8 ml)
	-12	1500 psi (103 bar)	.36 cu in (5.9 ml)
M, MS, 29723*	-21	2600 psi (179 bar)	.2 cu in (3.3 ml)
	-36	4500 psi (310 bar)	.12 cu in (2.0 ml)
	-71	8800 psi (607 bar)	.06 cu in (1.0 ml)
	-110	13500 psi (931 bar)	.039 cu in (0.6 ml)
	-188	15000 psi (1034 bar)	.023 cu in (.4 ml)
MS	-220	25000 psi (1723 bar)	.021 cu in (.34 ml)

\*Note: 29723 series rated to 10,000 psi (690 bar) maximum (ratios -110 and -188)

For service codes, see page 17.  
For weights and dimensions, see page 18.

## .75 hp (.56 kW) Pump Models



Model	Nominal Ratio	Maximum Working Pressure <small>Consult chart on page 8 for more information regarding continuous/intermittent pressures.</small>	Displacement per Cycle
4B	-14	1500 psi (103 bar)	.9 cu in (14.8 ml)
	-30	3200 psi (221 bar)	.43 cu in (7.1 ml)
	-37	3800 psi (262 bar)	.35 cu in (5.7 ml)
	-55	6000 psi (414 bar)	.22 cu in (3.6 ml)
	-100	10600 psi (731 bar)	.13 cu in (2.1 ml)

For service codes, see page 17.  
For weights and dimensions, see page 18.

### Key Features

- One model available in 5 ratios
- Output pressures to 10,000 psi (690 bar)
- Flows to 1.5 gpm (5.7 l/min)
- Choice of wetted materials
- Single air head
- Drive pressure 3 psi to 100 psi (.2 to 7 bar)

### Optional Modifications

Number	Description
57839	Low drive air pressure. Allows user to regulate drive air to as low as 3 psi (.2 bar).
59354	Noise reduction kit fitted.
81575	Changes the "F" seal to a "W" seal. Recommend for use with water.
82104	Viton air drive.

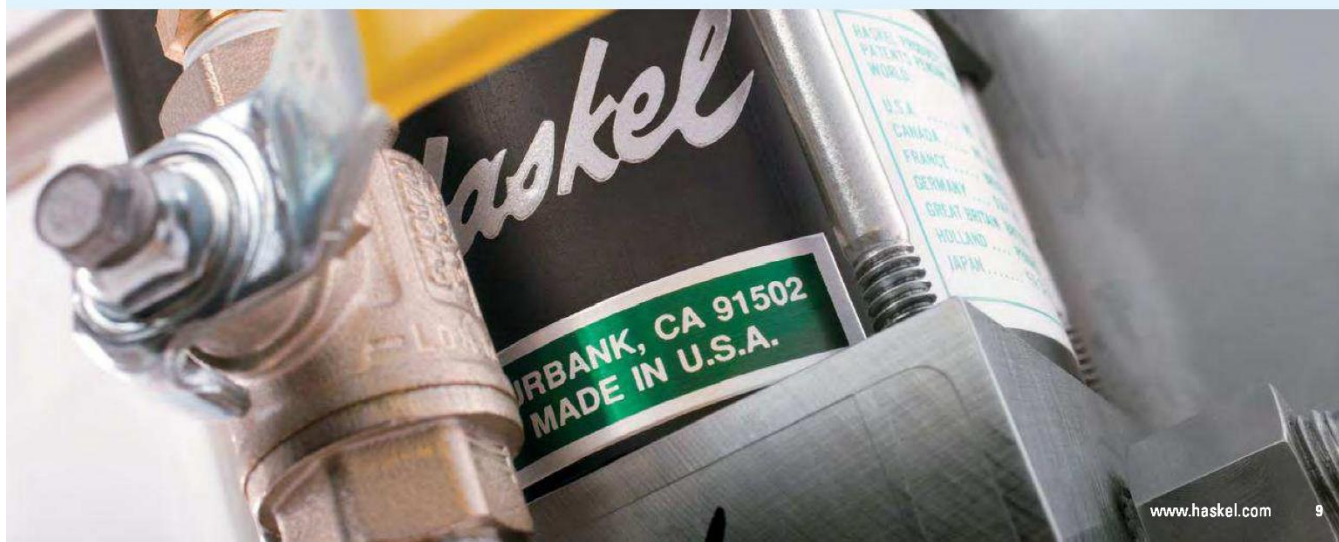

## 1.5 hp (1.12 kW) Pump Models



### Key Features

- Choice of 10 models, 13 ratios, 50 possible combinations
- Choice of wetted materials
- Output pressures to 50,000 psi (3448 bar)
- Single air head
- Flows to 22 gpm (83.0 l/min)
- Drive pressure 3 to 150 ps (2 to 10 bar)

### Optional Modifications

Number	Description
16821	Low air pressure control feature. For operating at air pressures as low as 3 to 4 psi (2 to .3 bar). Includes 28881 modification. 45 psi minimum pilot air required.
16831	Low temperature modification. For special sealing in air drive for operating temperatures from as low as -20°F up to normal +120°F.
16834	Exhaust adapter. With back pressure balance piston.
27964	Interconnecting inlet-outlet tubing. 1/2" female for 4:1 ratio series pumps (ATV-4 or DTV-4).
28000	Threaded vent (or purge) ports on standard distance piece. Except 1.5:1 ratio.
28881	Air pilot modification. 1/8" NPT. Allows remote start/stop of pump.
29376	Three-way cycling spool. For 1.5 hp and 2 hp single acting pumps, for use with CO2
29702	Single stroke modification.
51050	Extreme service cycling modification. Not recommended for long stall periods.
51056	Exhaust/pilot vent combination.
51331	EPR (Ethylene propylene) static seals in wetted section. Applies to distance piece pumps only.
51345	Sour gas drive provision to N.A.C.E. specifications. 1.5 hp to 2.2 hp distance piece pumps only, single air head and double air head.
52788	Viton seals air drive.
53925	Severe Arctic low temperature service. -25, -35, -60, -100, -150, -151, -225, -300, -450 ratios.
54885	Rotate pump body 90° from standard.
54935	SS trim for 5/3 air drive.
55516	Polyurethane ("W") seal. For F or TV series pumps, except high output models.
59353	Noise reduction kit fitted. Not available on AFD, DFD, ASFD or DSFD.
82460	HNBR seals in air drive section.

Model	Nominal Ratio	Maximum Working Pressure	Displacement per Cycle
		Consult chart on page 6 for more information regarding continuous/intermittent pressures.	
DSTV <sup>(1)</sup>	-1.5	160 psi (11 bar)	31.9 cu in (513.0 ml)
ATV, DTV <sup>(1)(2)</sup> DTN <sup>(1)</sup>	-4	1200 psi (83 bar)	20.0 cu in (328.0 ml)
AW, ASF, DSF, DSTV	-B10	1600 psi (110 bar)	4 cu in (66.4 ml)
	-B15	2400 psi (165 bar)	2.7 cu in (44.3 ml)
	-25	4000 psi (276 bar)	1.6 cu in (26.6 ml)
	-35	5700 psi (393 bar)	1.2 cu in (19 ml)
	-60	9800 psi (676 bar)	.7 cu in (11 ml)
ATV	-8	850 psi (59 bar)	20 cu in (328.0 ml)
AW, ASF, DSF, DSTV	-100	16500 psi (1138 bar)	.4 cu in (6.7 ml)
	-150	20000 psi (1375 bar)	.28 cu in (4.5 ml)
HF, HSF, DSHF	-151	25000 psi (1724 bar)	.28 cu in (4.5 ml)
	-225	37000 psi (2551 bar)	.18 cu in (3.0 ml)
	-300	50000 psi (3448 bar)	.14 cu in (2.3 ml)
HF	-450	45000 psi (3403 bar)	.09 cu in (1.5 ml)

(1) These series are "Lift" pumps and maximum outlet pressure is (air drive x pump ratio) + inlet pressure

(2) DTV has poppet checks

**For service codes, see page 17.  
For weights and dimensions, see page 20.**

### 1.5 hp (1.12 kW) High Output Flow Pumps

Available in a choice of 4 models, these high output, low ratio pumps are capable of pressures to 1200 psi (82 bar) and flow rates of up to 22 gpm (83 l/min). These are "lift" pumps whereby the outlet pressure equals the air drive x the pump ratio plus the inlet pressure.

Model DSTV-1.5 has a maximum air drive of 150 psi (10 bar) and is capable of pressures up to 160 psi (11 bar). The model ATV, DTN-4 and DTV-4 work on a maximum air drive of 150 psi (10 bar) and have a maximum intermittent pressure rating of 1200 psi (83 bar). A noise reduction modification is available for applications where noise level is an issue.

### Distance Piece (Separation)

Pumps with prefix "D" in the model number have aluminum distance piece between the air drive and pump section (except DSTV-1.5).

### Mounting Brackets

All series mounting brackets have 7/16" holes (slots) for 3/8" bolts. Upper mounting brackets are not furnished as standard on single air head non-distance piece units.

#### Dimensional Data

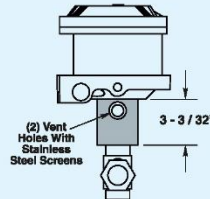

#### Mounting Brackets

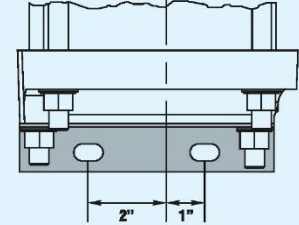

## 2 & 2.2 hp (1.49 & 1.64 kW) Pump Models



### Key Features

- Choice of 16 models, 13 ratios, 46 possible combinations
- Choice of wetted materials
- Double and triple air heads
- Output pressures to 100000 psi (7000 bar)
- Flows to 5 gpm (15 l/min)
- Drive pressure 3 to 100 psi (.2 to 7 bar)

When using high pressure ratio pumps the reliability of the XH models (-452 through -1373) will be improved with an air driven supercharge pump, not only to simplify priming but to reduce fatigue stresses. The higher the supercharge, the better the results. Also install a relief valve to protect the lower pressure pump from potential back pressure. Supercharging of the -1373 model is recommended. This approach will ensure a reasonable life for the seals and other wear components.

Model	Nominal Ratio	Maximum Working Pressure <small>Consult chart on page 6 for more information regarding continuous/intermittent pressures.</small>	Displacement per Cycle
AW, ASF, DSF, DSTV	-B22	3200 psi (221 bar)	4 cu in (66.4 ml)
	-B32	4800 psi (331 bar)	2.7 cu in (44.3 ml)
	-52	8000 psi (552 bar)	1.6 cu in (26.6 ml)
	-72	11000 psi (758 bar)	1.2 cu in (19 ml)
	-122	19000 psi (1310 bar)	.7 cu in (11 ml)
HF, HSF, DSHF	-202	33000 psi (2275 bar)	.4 cu in (6.7 ml)
	-302	50000 psi (3448 bar)	.28 cu in (4.5 ml)
DSXHF	-452	70000 psi (4827 bar)	.18 cu in (3.0 ml)
	-602	75000 psi (5171 bar)	.14 cu in (2.3 ml)
DSXHF	-683	70000 psi (4827 bar)	.18 cu in (3.0 ml)
	-903	75000 psi (5171 bar)	.14 cu in (2.3 ml)
DSXHW	-1373	100000 psi (6895 bar)	.09 cu in (1.4 ml)
AFD, DSFD, DFD, ASFD	-B60	6500 psi (448 bar)	1.3 cu in (22 ml)

For service codes, see page 17.  
For weights and dimensions, see page 20.

## 3 hp (2.24 kW) Pump Models



### Key Features

- One model available in 8 ratios
- Output pressures to 33000 psi (2275 bar)
- Flow rates to 8 gpm (30 l/min)
- Single air head
- Drive pressure 3 to 150 psi (.2 to 10 bar)

For service codes, see page 17.  
For weights and dimensions, see page 20.

Model	Nominal Ratio	Maximum Working Pressure <small>Consult chart on page 6 for more information regarding continuous/intermittent pressures.</small>	Displacement per Cycle
ASFD	10	1800 psi (110 bar)	8.1 cu in (132.8 ml)
	15	2400 psi (165 bar)	5.4 cu in (88.6 ml)
	25	4000 psi (276 bar)	3.3 cu in (53.2 ml)
	35	5700 psi (393 bar)	2.3 cu in (38 ml)
	60	9800 psi (676 bar)	1.3 cu in (22 ml)
	100	16500 psi (1138 bar)	.8 cu in (13.4 ml)
	150	20000 psi (1379 bar)	.6 cu in (9 ml)
	202	33000 psi (2275 bar)	.8 cu in (13.4 ml)

For service codes, see page 17.  
For weights and dimensions, see page 21.

**Optional Modifications (for 2 hp, 2.2 hp and 3 hp pump models)**

Number	Description
18821	Assures reliable drive operation with pressures low as 3 psi as long as 20 psi or more is provided to the separate 1/8" NPT port.
18831	Low temperature modification. For special sealing in air drive for operating temperatures from as low as -20°F up to normal +120°F.
18834	Exhaust adapter. With back pressure balance piston.
29376	Three-way cycling spool. For 1.5 hp and 2 hp single acting pumps.
51050	Extreme service cycling modification. Not recommended for long stall periods.
51056	Exhaust/pilot vent combination.
51331	EPR (Ethylene propylene) static seals in wetted section. Applies to distance piece pumps only.
51345	Sour gas drive provision to N.A.C.E. specifications. 1.5 hp to 2.2 hp distance piece pumps only, single air head and double air head.
52788	Viton seals. Air drive only - 1.5 hp to 2.2 hp pumps only.
53925-4	Severe Arctic low temperature service. -10, -15, -22, -32
54885	Rotate pump body 90° from standard. Except 3 hp pump.
54935	SS trim for 5/3 air drive.
55516	Polyurethane ("W") seal. For F or TV series pumps, except high output models.
59353	Noise reduction kit fitted. Not available on AFD, DFD, ASFD or DSFD.
55465	Ceramic Plunger -80 Ratio.
55516	Polyurethane "W" seal in "F" series pumps-except high output models.
59353	Noise reduction kit fitted. Not available on AFD, DFD, ASFD or DSFD.
59888	Cycle timer installed.
82460	HNBR Seals in air drive section.

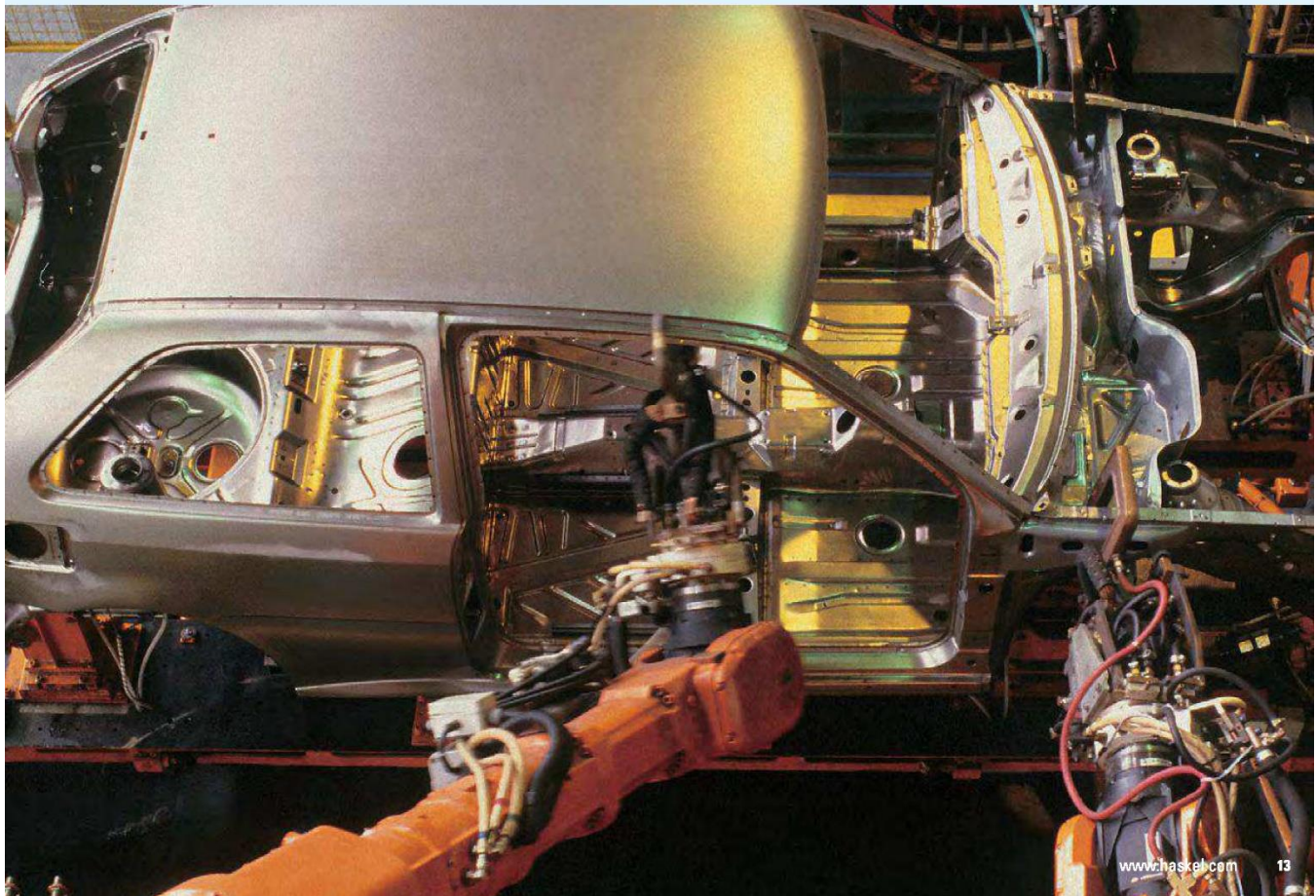

## 6 hp (4.47 kW) Pump Models



### Key Features

- Choice of 10 models, 4 ratios, 20 possible combinations
- Output pressures to 10,000 psi (690 bar)
- Flow rates to 21 gpm (80 l/min)
- Choice of wetted materials
- Single air head – double acting
- Drive pressure 3 to 125 psi (.2 to 9 bar)
- All hydraulic fluids, water (plain or DI), solvents

Model	Nominal Ratio	Maximum Working Pressure <small>Consult chart on page 6 for more information regarding continuous/intermittent pressures.</small>	Displacement per Cycle
GWD, GSFD, DGSFD <sup>(1)</sup> , DGSTVD <sup>(1)</sup>	-12	4000 psi (276 bar)	15.9 cu in (260 ml)
GW, GSF,	-35	4375 psi (302 bar)	6.0 cu in (98 ml)
DGSF,	-60	7500 psi (517 bar)	3.5 cu in (57 ml)
DGSTV	-100	10000 psi (690 bar)	2.1 cu in (34.5 ml)

(1) Double Acting "Lift" Pumps

*For service codes, see page 17.  
For weights and dimensions, see page 22.*

Incorporating 10 models, this heavy duty range of double acting pumps provide pressures up to 10,000 psi (690 bar) and flow rates up to 4 gpm (15 l/min).

Designed to operate with air drive pressures between 40 and 125 psi (2.8 and 9 bar). For drive pressures 3 to 40 psi (.2 to 2.8 bar), order 51875-1 mod.

## 8 hp (5.97 kW) Pump Models



### Key Features

- Choice of 9 models, 8 ratios, 9 possible combinations
- Pressures to 30,000 psi (2068 bar)
- Flow rates to 11.5 gpm (44 l/min)
- All hydraulic fluids, water (plain or DI), solvents, liquefied gases
- Choice of wetted materials
- Single air head – double acting
- Drive pressure 3 to 125 psi (.2 to 9 bar)

Model	Nominal Ratio	Maximum Working Pressure <small>Consult chart on page 6 for more information regarding continuous/intermittent pressures.</small>	Displacement per Cycle
8SFD, 8DSFD, 8DSTVD 8FD	-25 <sup>(1)</sup>	4000 psi (276 bar)	14 cu in (229 ml)
8SFD	-40	6000 psi (408 bar)	9 cu in (145.3 ml)
	-65	10000 psi (690 bar)	5.4 cu in (88.2 ml)
8DSFD	-100 <sup>(1)</sup>	10000 psi (690 bar)	3.5 cu in (57.5 ml)
8SFD <sup>(1)</sup>	-55	7200 psi (496 bar)	14 cu in (229 ml)
	-88	10000 psi (786 bar)	8.83 cu in (144 ml)
	-224	29000 psi (1724 bar)	3.5 cu in (57 ml)
8HSFD	-225 <sup>(1)</sup>	25000 psi (1724 bar)	1.6 cu in (25.5 ml)

(1) Double Acting "Lift" Pumps

*For service codes, see page 17.  
For weights and dimensions, see page 21.*

## 10 hp (7.46 kW) Pump Models



### Key Features

- Choice of 4 models, 4 ratios, 4 possible combinations
- Pressures to 36000 psi (2500 bar)
- Flow rates to 3 gpm (11 l/min)
- Drive pressure 3 to 125 psi (.2 to 9 bar)
- All hydraulic fluids, water (plain or DI), solvents, liquefied gases
- Choice of wetted materials

### Optional Modifications (for 6 hp, 8 hp and 10 hp pump)

Number	Description
29125	External pilot modification – for 6 hp thru 10 hp pumps.
87410	Low air pressure control – for 6 hp thru 10 hp pumps.
54030	Sour gas air drive provision to NACE spec. 6 hp distance piece pumps only.
54936	Exhaust/pilot vent combiner.
57002	Viton seals – air drive only – 6 hp
57944	Viton seals – air drive only – 8 hp
59888	Cycle timer installed.

Model	Nominal Ratio	Maximum Working Pressure	Displacement per Cycle
		Consult chart on page 6 for more information regarding continuous/intermittent pressures.	
D14STD	125 <sup>(1)</sup>	16000 psi (1103 bar)	8.8 cu in (144.2 ml)
	315 <sup>(1)</sup>	36000 psi (2482 bar)	3.5 cu in (57.4 ml)
D14SFD	125 <sup>(1)</sup>	16000 psi (1103 bar)	8.8 cu in (144.2 ml)
	315 <sup>(1)</sup>	36000 psi (2482 bar)	3.5 cu in (57.4 ml)

(1) Double Acting "Lift" Pumps

For service codes, see page 17.  
For weights and dimensions, see page 21.

Incorporating two basic models, this heavy duty range of double acting pumps provide pressures up to 36000 psi (2482 bar) and output flow rate up to 3 gpm (11 l/min).

Operating from a maximum air drive pressure of 125 psi (9 bar), these pumps are designed for medium to high pressure service with minimum maintenance.

These large, slow speed pumps approach a seal life as high as 5 times that of many smaller pumps and this advantage becomes ever greater in heavy duty service involving water, or other liquids with negligible lubricity.



## Power System Specialists

World safety standards and quality demands are rising. Component manufacturers are required to provide test certification and product quality assurance which can only be determined using the types of systems which Haskel can provide. Typically, we have built systems for production and field testing the proof, leak, and burst aspects of hoses, cylinders, and valves.

These systems can be portable, mobile, or static test rigs. We also offer a range of standard pressure packs used for power jacking, clamping, and other applications where reliable power is needed.

## Selecting Your Accessories

Haskel can either provide accessories separately or supply them fitted to form a complete package suited to your application. Additionally, Haskel can fit customer nominated accessories. Our accessories catalog is available and our technical support team is always ready to advise you on the most suitable choice of accessories for your application.

- Air pilot switches
- Air pilot valves
- Regulating relief valves
- Directional control and release valves
- Hydraulic accumulators, gas receivers and storage cylinders
- High pressure valves, fittings and tubing
- Plenum chambers
- Port adapters
- Gauge snubbers
- Filters
- Stainless steel check valves
- Intensifiers with integral checks for cycling
- Capillary type gauge snubbers

## Quality and After-Sale Service



Haskel meets the requirements of international quality assurance ISO 9001. Build quality is matched by an innovative design and problem solving ability which stems from years of experience. Our representatives around the world are carefully chosen and trained to help you arrive at a correct product choice, and to offer a maintenance and parts service that is second to none.

*Please ask for your copy of our latest accessories brochure.*



## Liquids Compatible with Haskel Pumps

To assist in easier pump selection, we have classified various popular liquids in groups and assigned to each group a service code. These service code numbers are featured in the chart to the right and are designated for each pump series. Seals and other wetted materials can be supplied to suit your preferred liquid. For advice, please contact our technical services personnel at 818-843-4000.

## Services

### Service Codes

- 1** Petroleum-based oils, kerosene, ethylene glycol, water with 5% soluble oil.
  - 2** Plain water, diesel fuel.
  - 3** Most phosphate ester-based fire-resistant hydraulic fluids, e.g. Pydraul, Lindol, Cellulube, Fyrquel, and Houghtosafe 1120 and petroleum-based solvents compatible with UHMWPE (Ultra-high Molecular Weight Polyethylene) dynamic seals and Viton static seals.
  - 4** Petroleum-based solvents, e.g. aromatic hydrocarbons (benzene, toluene, xylene, hylene, etc.); chlorinated solvents (trichlorethylene, carbon tetrachloride, chlorobenzine, etc.); mercaptans, Dowtherm A, fluoronated solvents (fluorobenzene, fluorochlorethylene, etc.); Dowtherm E, plus all of Group 3 and some mildly corrosive acids compatible with wetted materials. See note 5A for service with methyl-ethyl-ketone, methyl acetone, diacetone, alcohol and freon 22.
  - 5** Skydrol and Aerosafe hydraulic fluid; acetone and some alcohols (ethyl, methyl, and isopropyl).
- 5A.** Also suitable for these fluids if Viton static seals are replaced with EPR; specify modification number 51331 (no extra charge); e.g., 51331-MDTV-5. Most phosphate ester-based fluids solidify at approximately 30000 psi.
- 6** Deionized water; demineralized water.

*Note: Dynamic seal life with non-lubricating fluids will understandably be less than with lubricating types.*

## Operating Temperatures

### Drive Section

-4° (25°F) to +65°C (150°F) (low temperature seals are available for Arctic operation).

### Liquid Section

For reasonable seal life, high temperature should be limited to 54° C (130° F), for F and W seal models, 135° C (275° F) for T and TV models (with distance piece).

		Services					
hp	Model	1	2	3	4	5	6
.33	M	•					
	MS	•	•				•
	MDSTV	•	•	•	•	•	•
	29723	•	•	•		•	•
.75	4B -14 to -37	•	•				•
	4B -55 to -100	•	•				•
1.5 2 2.2	AW	•					
	ASF	•	•				•
	DSF	•	•	•		•	•
	HF	•	•				
	HSF	•	•				•
	DSHF	•	•			•	•
	DSTV	•	•	•	•	•	•
	ATV	•	•	•			•
	DTV	•	•			•	•
	DSTV-1.5	•	•		•	•	•
	AFD	•		•			
	DFD	•		•		•	
	ASFD	•	•				•
DSFD	•	•	•		•	•	
DSXHF	•	•			•	•	
DSXHW	•	•				•	
3	ASFD	•	•				•
6	GW	•					•
	GSF	•	•				•
	DGSF	•	•	•		•	•
	DGSTV	•	•	•	•	•	•
	GWd	•					•
	GSFD	•	•	•		•	•
	DGFD	•		•		•	•
	DGSFD	•	•	•	•	•	•
DGSTVD	•	•	•	•	•	•	
8	8FD	•					•
	8SFD	•	•	•	•	•	•
	8SFD2	•	•	•	•	•	•
	8DSFD	•	•	•		•	•
	8DSTVD	•	•	•		•	•
	8HSFD	•	•	•	•	•	•
10	D14STD-125	•	•	•	•	•	•
	D14STD-315	•	•		•	•	•
	D14SFD-125	•	•	•		•	•
	D14SFD-315	•	•	•		•	•

# Weights and Dimensions

## .33 hp (.25 kW) M Series Pump Models

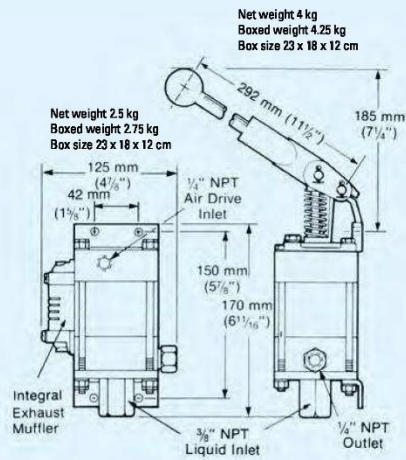
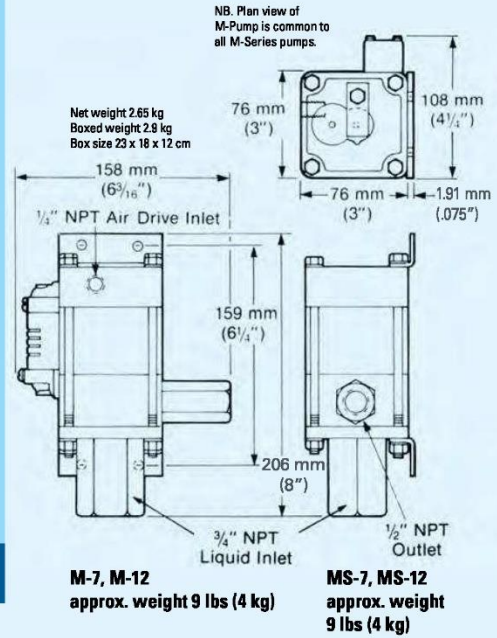

**MS-21, MS-36, MS-71, MS-110, MS-188, approx. weight 6 lbs (2.7 kg)**

**M-21, M-36, M-71, M-110, M-188 approx. weight 6 lbs (2.7 kg)**

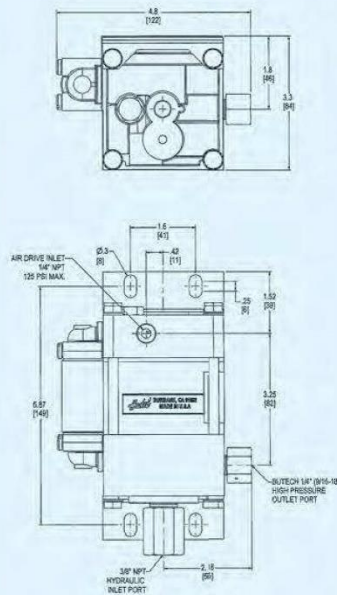

**MS-220 approx. weight 6 lbs (2.7 kg)**

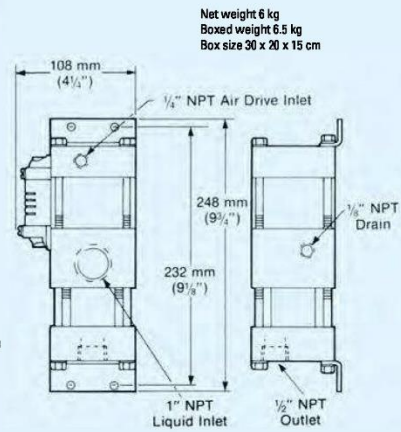

**M-5 approx. weight 9 lbs (4 kg)**

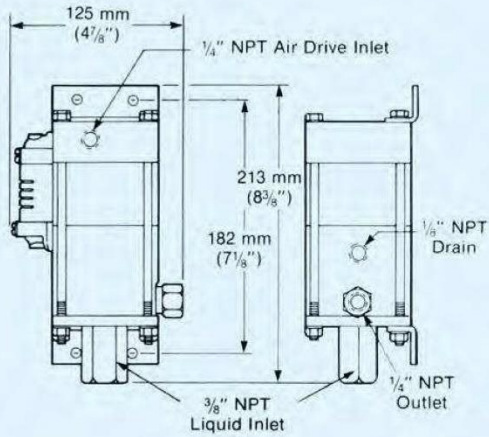

29723-21, 29723-36, 29723-71, 29723-110  
approx. weight 6.5 lbs (3 kg)

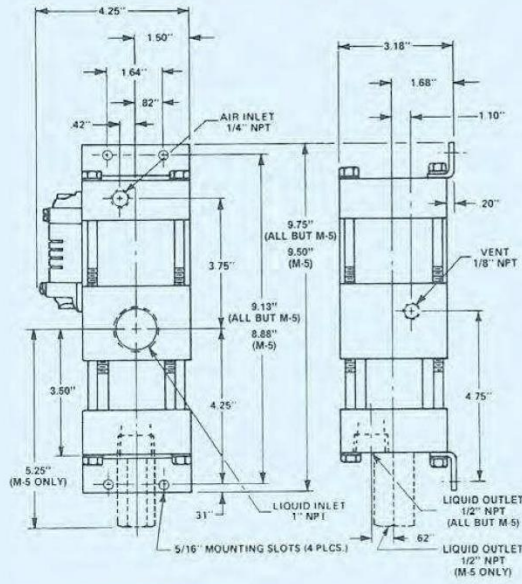

MDSTV-5, MDTV  
Approx weight 15 1/2 lbs (7 kg)

**.75 hp (.56 kW) Pump Models**

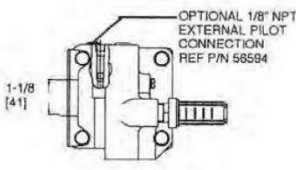
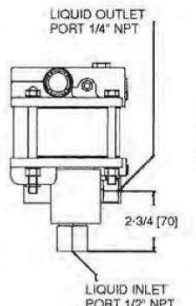
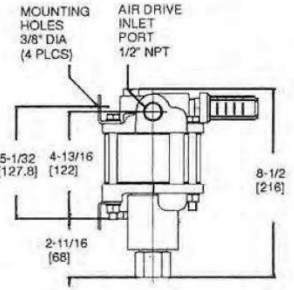
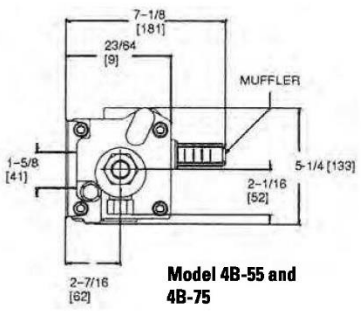
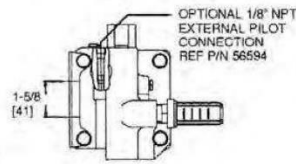
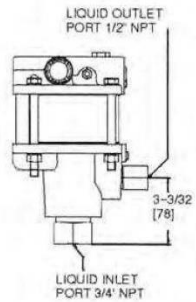
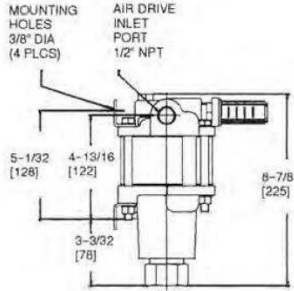
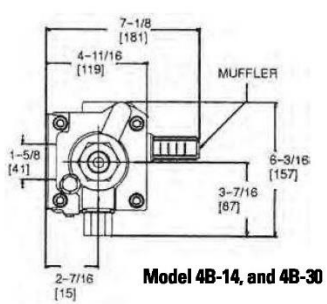

## 1.5 hp, 2 & 2.2 hp (1.12, 1.49 & 1.64 kW) Pump Models

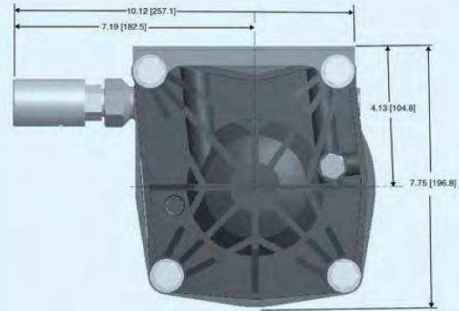
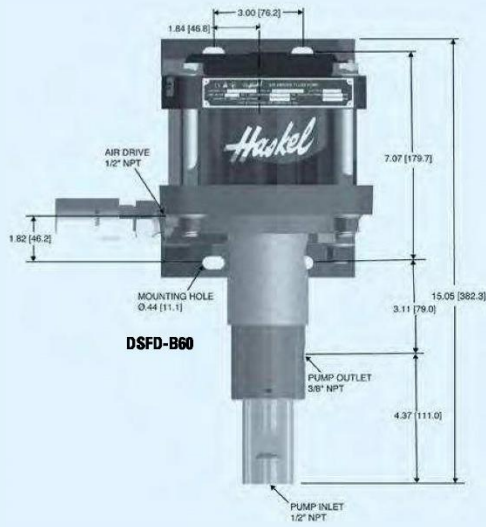

Net weight 18 kg  
 Boxed weight 20 kg  
 Box size 68 x 42 x 50 cm

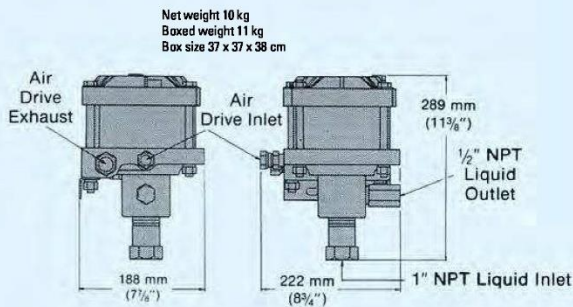

**1.5 and 2 hp low ratio pumps;  
 -B10 and -B15 ratios**

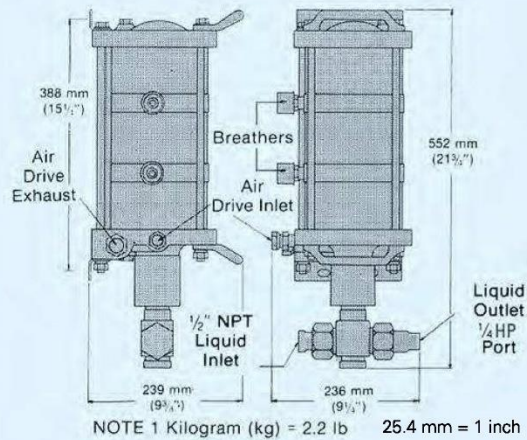

**2 hp high ratio pumps;  
 -683 and -903 ratios**

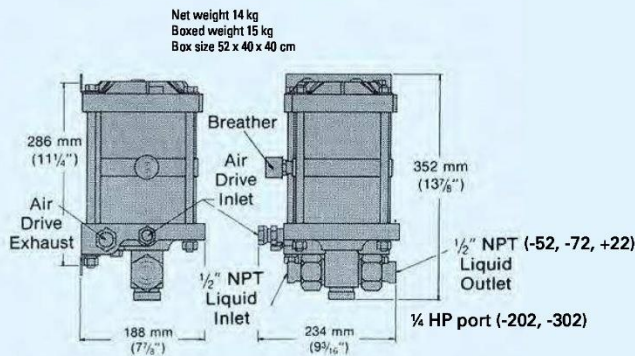

**1.5 and 2 hp medium ratio pumps;  
 -52, -72, -122, -202 and -302 ratios**

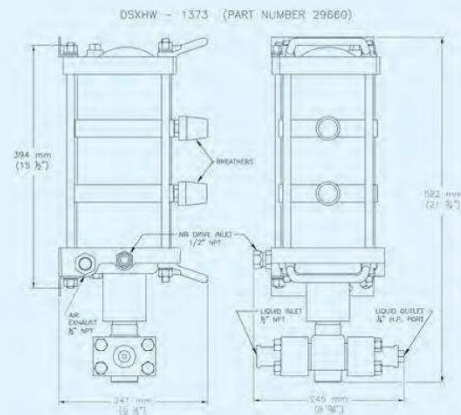

**2 hp (1.49 & 1.64 kW) Pump Models;  
 -1373 ratio**

**.75 hp (.56 kW) Pump Models (cont.)**

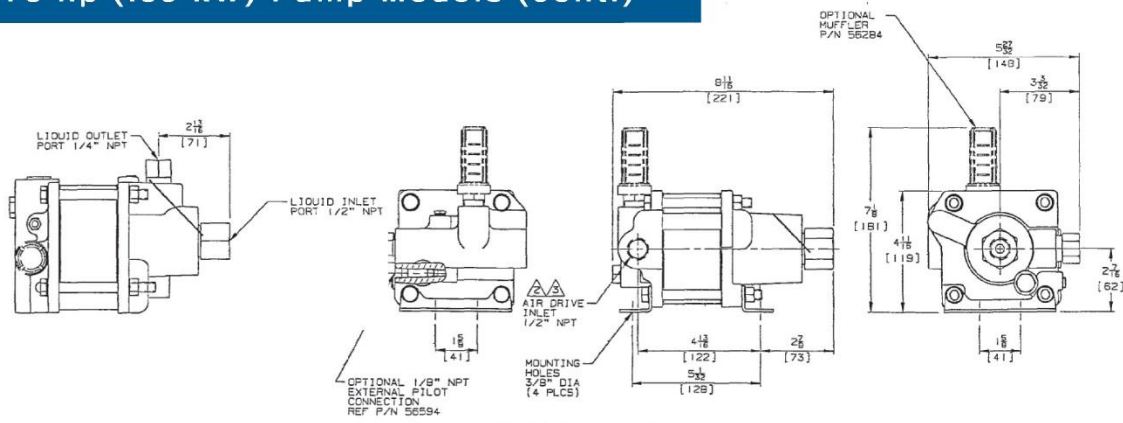

**Model 4B-37**  
approx. weight 10 lbs (4.5 kg)

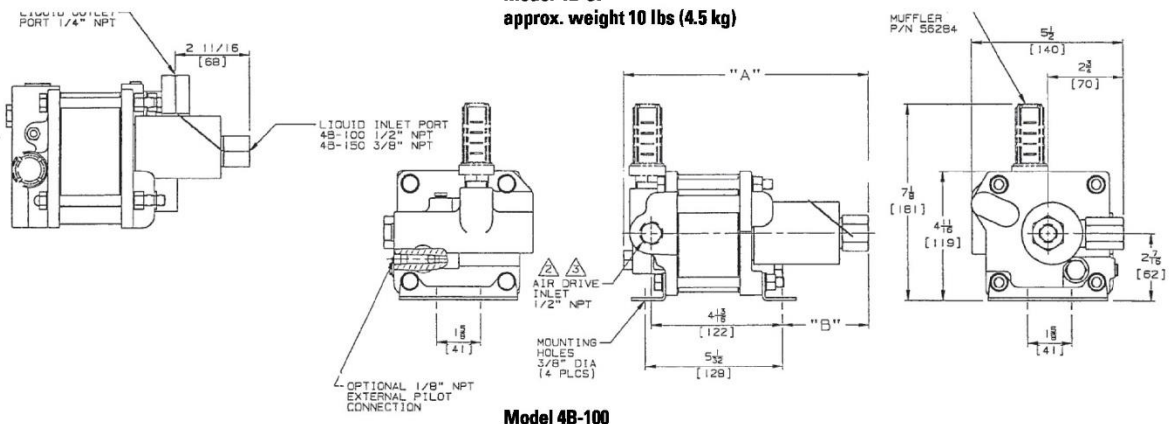

**Model 4B-100**  
approx. weight 11 lbs (5 kg)

**1.5 hp, 2 & 2.2 hp (1.12, 1.49 & 1.64 kW) Pump Models**

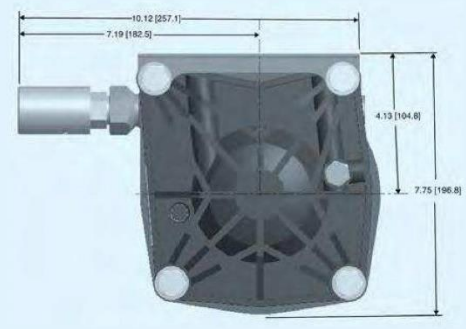
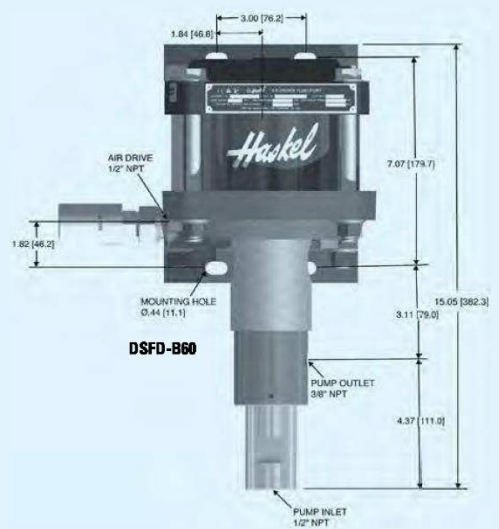

**1.5 hp, 2&2.2 hp (1.12, 1.49 & 1.64 kW) Pump Models (cont.)**

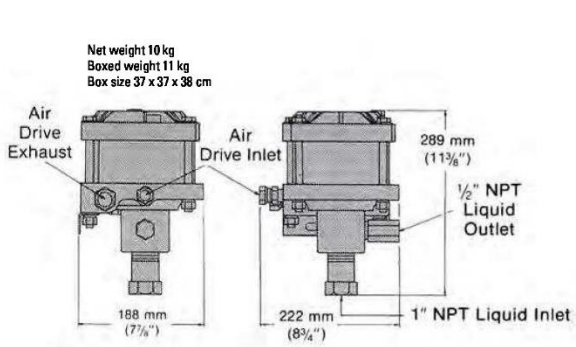

**1.5 and 2 hp low ratio pumps;  
-B10 and -B15 ratios**

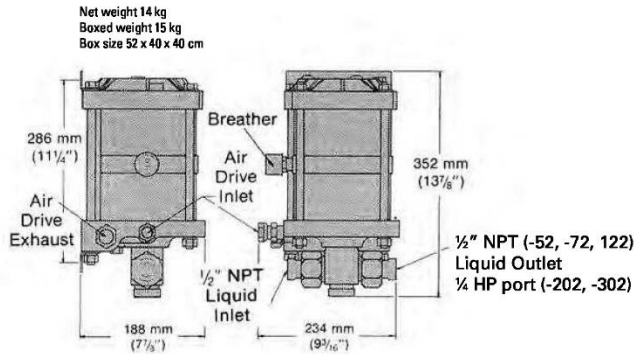

**1.5 and 2 hp medium ratio pumps;  
-52, -72, -122, -202 and -302 ratios**

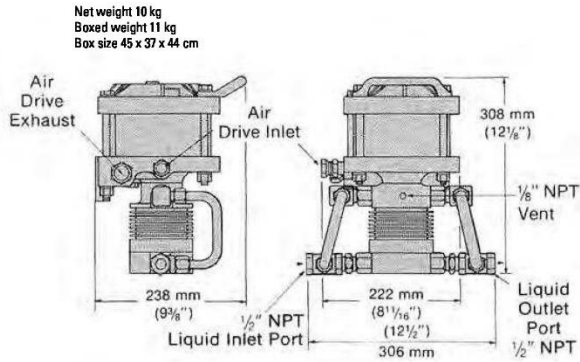

**ATV-4 pumps; double acting, high output**

Note: For model DTV-4, add distance piece dimension from page 11. Interconnecting inlet and outlet port tubing shown.

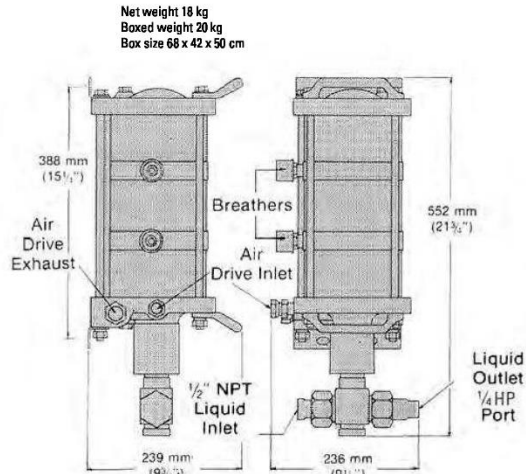

NOTE 1 Kilogram (kg) = 2.2 lb 25.4 mm = 1 inch

**2 hp high ratio pumps;  
-683 and -903 ratios**

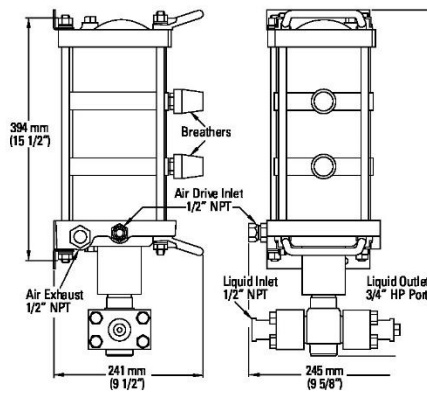

**2 hp (1.49 & 1.64 kW) pump models;  
-1373 ratio**

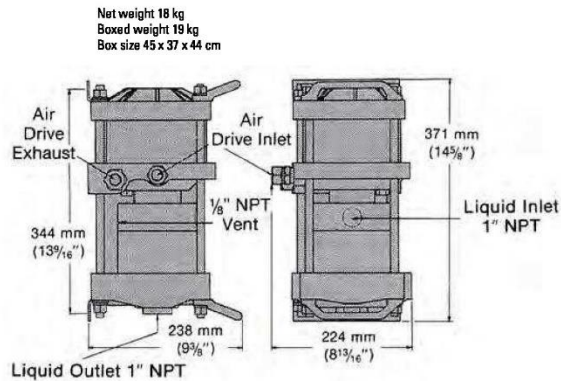

**DSTV-1.5 pump; single acting, high output**



## 6 hp (4.47 kW) Pump Models

Net weight 31 lbs (14 kg)  
 Boxed weight 35 lbs (16 kg)  
 Box size 52 x 39 x 39 cm

All models have 2 off 1/4" NPT air exhaust ports and 1 off 3/4" NPT air drive inlet ports.

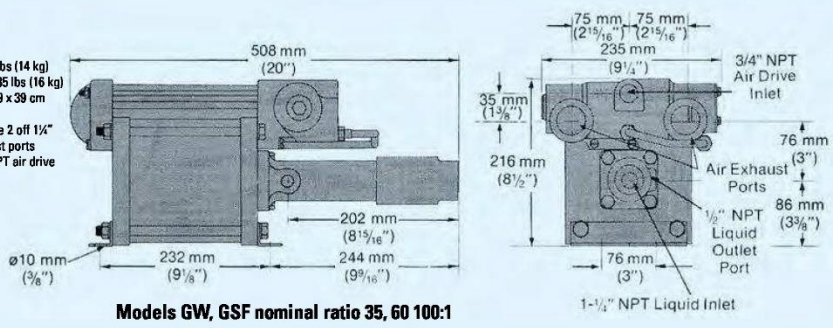

**Models GW, GSF nominal ratio 35, 60 100:1**

Net weight 41 lbs (18.5 kg)  
 Boxed weight 48 lbs (22 kg)  
 Box size 66 x 41 x 49 cm

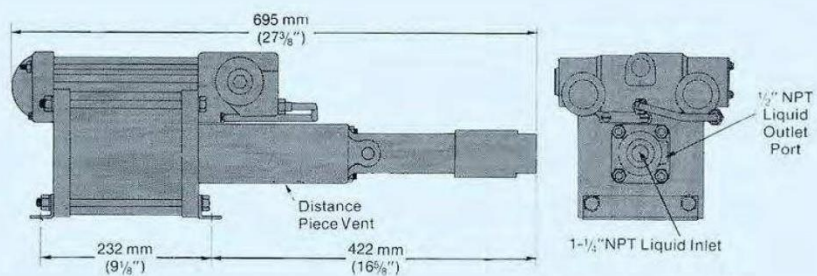

**Models DGSF, DGSTV nominal ratio 35, 60 100:1**

End dimensions as GW/GSF

Net weight 57 lbs (26 kg)  
 Boxed weight 61 lbs (27 kg)  
 Box size 66 x 41 x 49 cm

If interconnecting piping for the two inlets and two outlets is required, specify modification 29077 with your order.

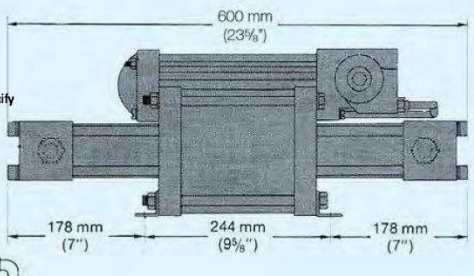
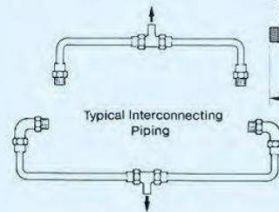

**Models GWD, GSFD nominal ratio 12:1**

End dimensions as GW/GSF

Net weight 66 lbs (30 kg)  
 Boxed weight 75 lbs (34 kg)  
 Box size 91 x 51 x 39 cm

If interconnecting piping for the two inlets and two outlets is required, specify modification 29078 with your order.

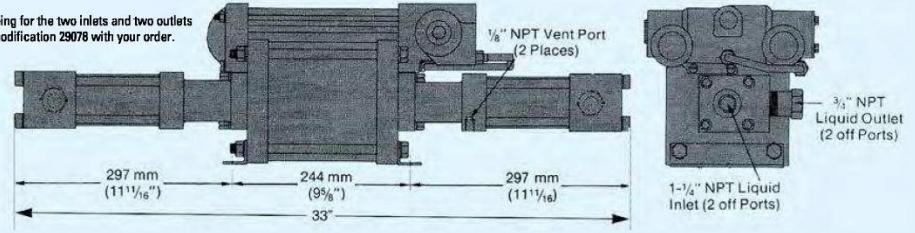

**Models DGSFD, DGSTV nominal ratio 12:1**

## 8 hp (5.97 kW) Pump Models

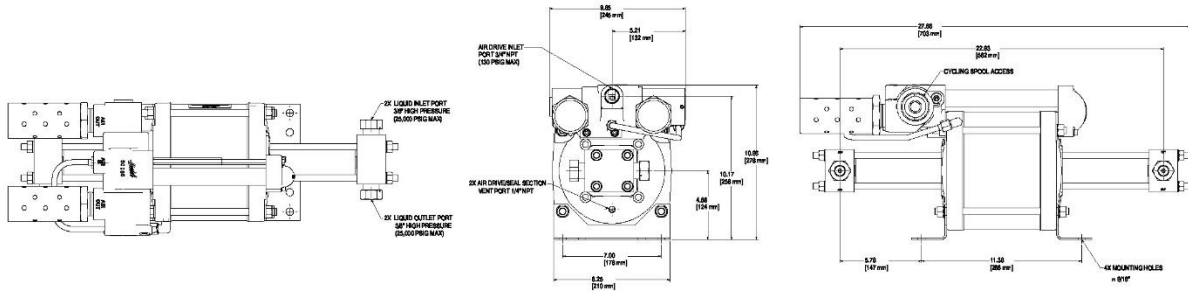

**Model 8HSFD-25**  
Inlet, Outlet ports 3/8" HP

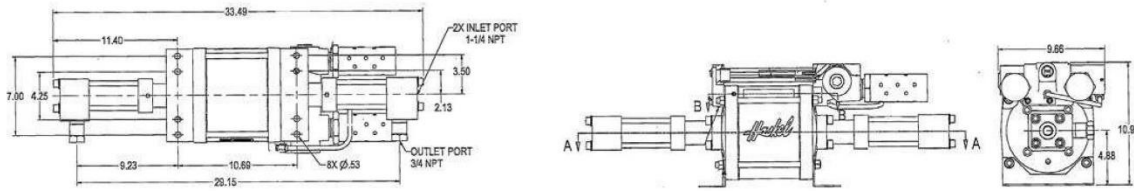

**Models 8DSFD-25 & 8DSTVD-25**

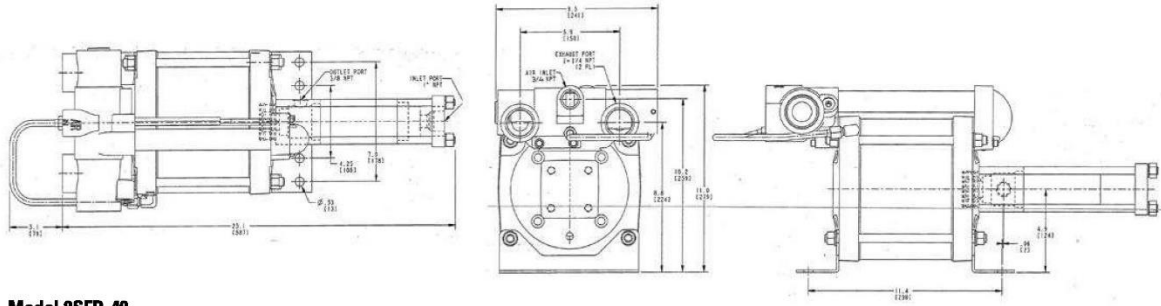

**Model 8SFD-40**

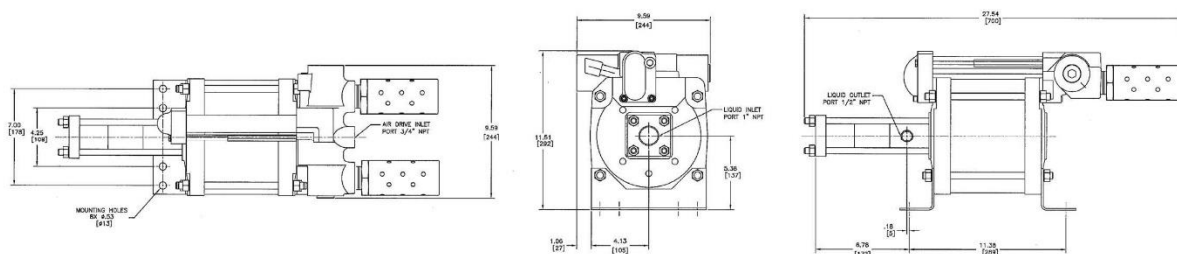

**Model 8SFD-65**

**8 hp (5.97 kW) Pump Models (cont.)**

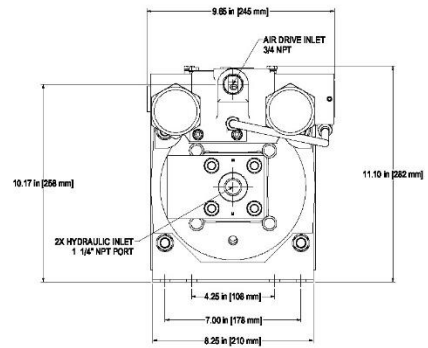
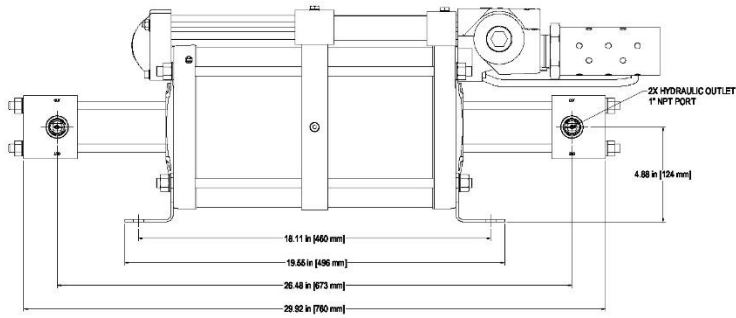
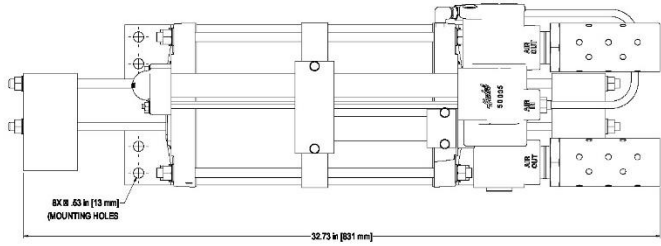

**Model 8SFD2-55**

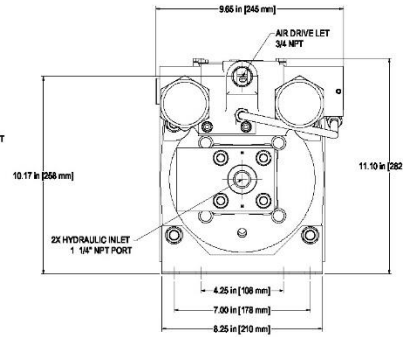
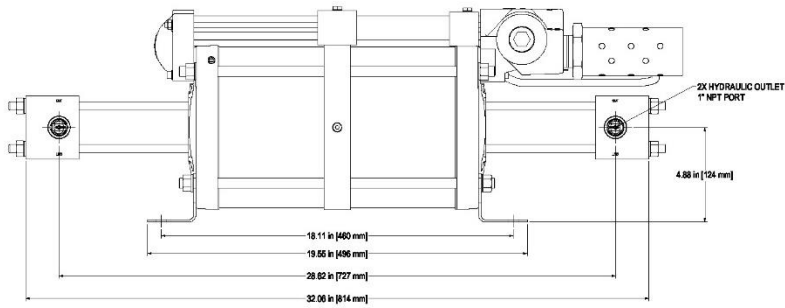
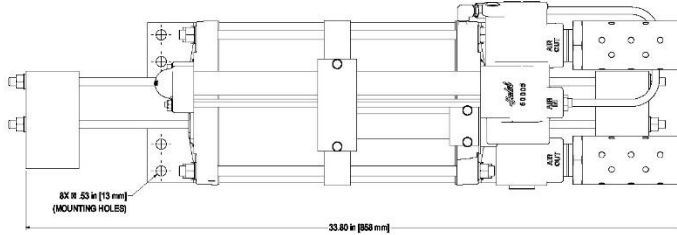

**Model 8SFD2-88**



**For more information on our high-pressure products, visit [Haskel.com](http://Haskel.com) or contact your local Haskel representative.**  
*Haskel is a brand of Accudyne Industries, a leading global provider of precision-engineered, process-critical and technologically advanced flow control systems and industrial compressors that deliver consistently high performance and give confidence to the mission of our customers in the most important industries and harshest environments around the world. The company is powered by more than 3,000 employees at 18 manufacturing facilities, supporting a broad range of industries in more than 150 countries.*

**Accudyne**  
INDUSTRIES

**Haskel**  
an Accudyne Industries brand

[haskel.com](http://haskel.com)  
[sales@haskel.com](mailto:sales@haskel.com)

LP-GL 04/17  
Printed in USA



## **APPENDIX III**

### **Declaration of Conformity**





## DECLARATION of CONFORMITY

The design, development and manufacture is in accordance with European Community guidelines

Hydraulic Beadbreaker  
14-6878-0110

Relevant provisions complied with by the machinery:  
2006/42/EC

Relevant standards complied with by the machinery:  
EN ISO 12100-1

Identification of person empowered to sign on behalf of the Manufacturer:

A handwritten signature in black ink that reads "Patrick Finch". The signature is written in a cursive style and is positioned above a solid horizontal line.

Quality Assurance Representative