

Date: June 6, 2016

MALABAR

INTERNATIONAL

AIRCRAFT MAINTENANCE & SUPPORT EQUIPMENT

OWNER'S MANUAL FOR MALABAR MODEL

PF55451-7

15 GALLON FLUID DISPENSER

***READ
AND
SAVE***

**THIS
INSTRUCTION
MANUAL**

- * GENERAL DESCRIPTION
- * OPERATION
- * SERVICE
- * PARTS BREAKDOWN

For Service & Spare
Parts, Please Contact:

Malabar International
220 W. Los Angeles Avenue
Simi Valley, California 93065
Phone: (805) 581-0116
Fax: (805) 584-1624
E-mail: sales@malabar.com
Web site: <http://www.malabar.com>

OVER 65 YEARS OF SERVICE & EXPERIENCE

GENERAL DESCRIPTION, OPERATION, SERVICE AND PARTS BREAKDOWN

MALABAR MODEL PF55451-7 15 GALLON FLUID DISPENSER

CAUTION: AIRCRAFT MANUFACTURER'S SPECIFICATIONS AND INSTRUCTIONS MUST BE FOLLOWED. IN THE EVENT OF CONTRADICTION BETWEEN AIRCRAFT MANUFACTURER'S SPECIFICATIONS AND MALABAR'S, AIRCRAFT MANUFACTURER'S WILL PREVAIL.

SPECIFICATIONS:

Fluid	PETROLEUM BASED	
Reservoir capacity	15 U.S. gal	56.8 liters
Relief valve set at	150 ± 10 psig	1034 ± 69 kPa
Volume per stroke	4.0 cubic in	65.5 cc
Hose length	120 in	3048 mm
Net weight (empty)	82 lbs	37.2 kg
Filter rating	3 micron nominal	

GENERAL DESCRIPTION:

The Malabar Model PF55451-7 is a 15 gallon fluid dispenser used to service various commercial aircraft. The hand pump dispenser consists of a reservoir, pump assembly with relief valve, fluid meter, filter assembly, and a fluid delivery hose with a coupling and a gravity fill adapter assembly.

PREPARATION FOR USE:

The unit is shipped fully assembled. Fill reservoir at fillport with approved fluid. Operate hand pump assembly a few strokes to bleed all air out of the system. The unit is now ready for use.

OPERATION:

1. Remove dust plug from hose coupling and connect the hose coupling to the aircraft service point.
2. Use full steady pumping strokes when operating pump assembly during replenishing.
3. Disconnect the hose coupling from the aircraft service point, replace the dust plug and store the unit in a dry, dust free location.

ILLUSTRATED PARTS LIST:

Refer to figure 1A & 1B for unit assembly (see sheets 5 & 6) or figure 2 for pump assembly (see sheet 7).

SERVICING:

1. The frequency of filter change depends on operating conditions. Generally, changes should be made every 3-4 months or sooner if more than normal resistance is felt on the pumping stroke at low pressure. Refer to item 8 in figure 1B (see sheet 6) to change the filter element.
2. Lubricate wheel bearings as required. Refer to item 12 in figure 1B (see sheet 6).

REPAIR AND REPLACEMENT:

No definite time schedule can be established for the overhaul of the pump assembly for the replacement of the various moving parts. The number of times the pump assembly is operated materially affect the life of the working parts. The moving piston seal (item 9) and scraper (item 8) are normally the first to wear (see sheet 7). This is usually indicated by leakage of fluid past the plunger (item 2). It is advisable to overhaul the pump assembly immediately if leakage is discovered as described below in overhaul instructions. A repair parts kit (P/N PF15-2PK) is available and recommended to keep on hand at your facility. Refer to sheet 8 for the complete list of parts contained in the repair parts kit.

OVERHAUL INSTRUCTIONS:

During overhaul, replace all parts that do not pass the following inspection requirements. Each time the pump assembly is disassembled, carefully inspect for the following:

Inspect interior walls of cylinder and outer walls of plunger and piston for smoothness and freedom from rust, pits, scratches and excessive wear. Check oil screen for cleanliness. Regardless of apparent condition, replace all o-rings, scrapers, retaining rings, gaskets, roll pins, flathead pins, cotter pins, ball valves and filter element. Coat all o-rings and back-up rings with compatible fluid prior to assembly. Clean all metal parts with clean solvent and dry with compressed air. Lubricate all threads. Use teflon

tape carefully on all pipe threads. Remove excess tape because it can clog valves and passages. If ball valves do not seat properly, they may need to be reseated by tapping the ball into the valve seat with a brass rod cupped at one end.

1. Hand pump disassembly (see figure 2):
 - a. Remove ten bolts and lockwashers (figure 1B, items 3 & 4) from cover (item 7) and lift pump assembly and gasket (figure 1B, items 1 & 2) from tank (figure 1A, item 1).
 - b. Remove handle (item 16) and pump link (item 17) by removing cotter pins (items 19) and flathead pins (items 18).
 - c. Remove tubing (item 26).
 - d. Unscrew nipple (item 20) and attached parts (items 20, 21, 22, 23 and 24) from valve body (item 4). Pull out valve body (item 4), adapter (item 5), nipple (item 13) and oil screen (item 14) from cylinder (item 1). Remove o-ring (item 9) from valve body.
 - e. Unscrew adapter (item 5), nipple (item 13) and oil screen (item 14) from valve body (item 4). Remove o-ring (item 28) and ball (item 12).
 - f. Tap out roll pin (item 15) from plunger (item 2) and slip off collar (item 6).
 - g. Pull plunger (item 2) and piston (item 3) out of cylinder (item 1).
 - h. Remove retaining ring (item 11) from plunger (item 2) and slide piston (item 3) off. Remove o-ring (item 10) from plunger and o-ring (item 9) from piston.
 - i. Unscrew cylinder (item 1) from cover (item 7).
 - j. Remove retaining ring (item 27) and scraper (item 8) from cover (item 7).
2. Hand pump reassembly (see figure 2):
 - a. Install scraper (item 8) and retaining ring (item 27) onto cover (item 7).
 - b. Screw cylinder (item 1) onto cover (item 7).
 - c. Install o-ring (item 10) onto plunger (item 2). Next install o-ring (item 9) onto piston (item 3). Finally install piston onto plunger and secure with retaining ring (item 11).
 - d. Slide plunger (item 2) and piston (item 3) assembly into cylinder (item 1).
 - e. Slide collar (item 6) onto plunger (item 2) and install roll pin (item 15) through both.
 - f. Install o-ring (item 9) onto valve body (item 4). Next install o-ring (item 28) onto adapter (item 5). Place steel ball (item 12) into valve body (item 4). Attach adapter (item 5), nipple (item 13) and oil screen (item 14) to valve body (item 4). Install the entire assembly into the cylinder (item 1) and align thread with hole in cylinder.
 - g. Attach nipple (item 20) and connected parts (items 20, 21, 22, 23 and 24) to valve body (item 4) and cylinder (item 1).
 - h. Attach tubing (item 26) to connectors (items 24 & 25).
 - i. Install handle (item 16), pump link (item 17), flathead pins (items 18) and cotter pins (items 19).
 - j. Place gasket (figure 1B, item 2) and pump assembly on tank (figure 1A, item 1). Install 10 bolts and 10 lockwashers (figure 1B, items 3 & 4) and secure pump assembly to the tank.

3. Relief valve setting (see figure 2):

Caution: The relief valve should not be adjusted unless absolutely necessary. If adjustment is required, proceed as follows:

- a. Remove pump assembly and gasket from tank as described in step 1a.
- b. Install tee, pressure gauge (0-200 psig) and shut off valve to the end of the hose assembly (figure 1A, item 7).
- c. Bleed air from pump assembly.
- d. Remove cap from end of relief valve (item 22) and loosen locknut on relief valve. Using 3/16 wrench, adjust relief valve to 150 ± 10 psig. Replace locknut and cap upon completion.
- e. Remove tee, shut off valve and pressure gauge from hose assembly.
- f. Attach gasket and pump assembly to tank as described in step 2j.

TROUBLE SHOOTING:

If pump assembly loses prime, pressure or volume output:

1. Check fluid level.
2. Dirt or foreign particles may be lodged in valve body or adapter assembly. Clean with solvent and dry with compressed air. Replace o-rings before reassembling.
3. Check condition of filter element. Replace as required.
4. Oil screen may be clogged. Clean with solvent and dry with compressed air.
5. Relief valve may need to be reset. Adjust relief valve per overhaul instructions.
6. Piston o-ring may be worn. Replace per overhaul instructions.
7. Hydraulic hose, fittings or tubing may be leaking. Tighten or replace as required.

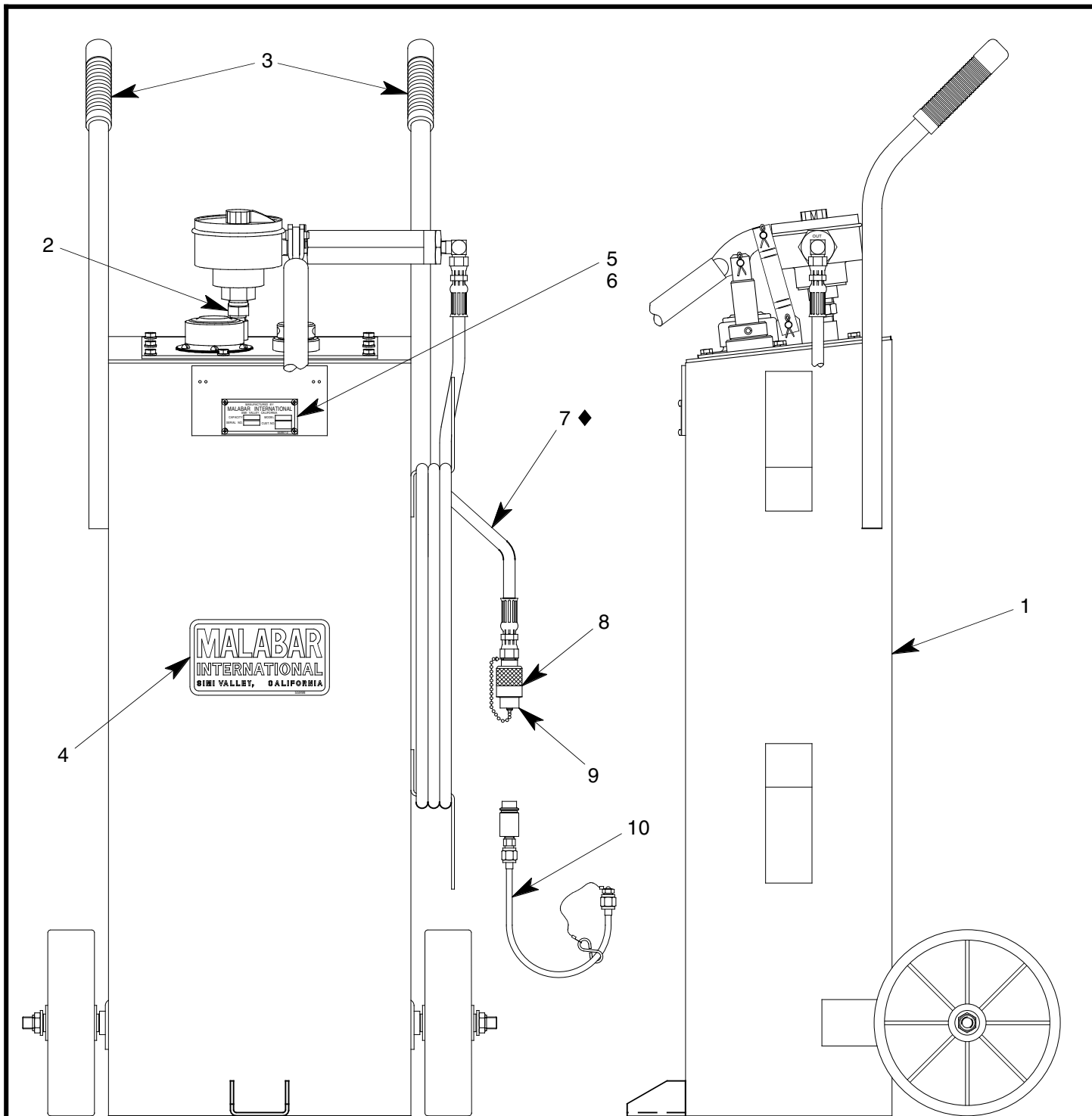

◆ PART OF REPAIR PARTS KIT

FIGURE 1A

PF55451-7 UNIT ASSEMBLY

NO.	QTY	PART NO.	PART NAME	NO.	QTY	PART NO.	PART NAME
1	1	PF53452	TANK	6	4	397-010	SELF TAPPING SCREW, 6-32
2	1	711-022	NIPPLE, 3/8 NPT x 1/2 NPT	7	1	PF55456	HOSE ASSEMBLY
3	2	494-006	HANDLE GRIP	8	1	736-013	COUPLING
4	1	55998	STICKER, MALABAR	9	1	PF55987	DUST PLUG & CHAIN ASSY
5	1	55997-2	NAMEPLATE	10	1	PF55759	GRAVITY FILL ADAPTER ASSY

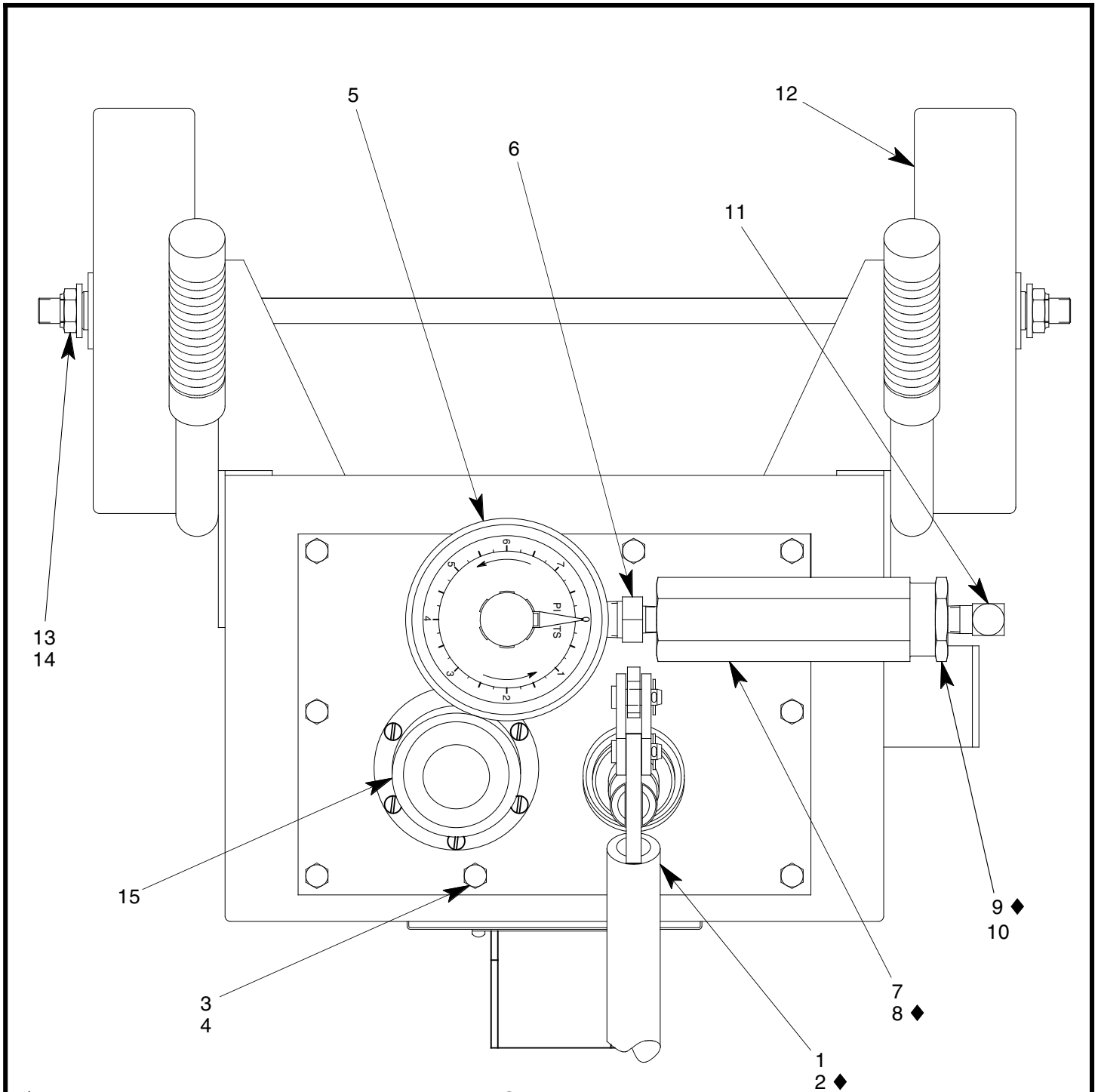

◆ PART OF REPAIR PARTS KIT

FIGURE 1B

PF55451-7 UNIT ASSEMBLY

NO.	QTY	PART NO.	PART NAME	NO.	QTY	PART NO.	PART NAME
1	1	PF55485-1	PUMP ASSEMBLY	9	1	55925-025	O-RING
2	1	PF53456	GASKET	10	1	PF101163	FILTER HOUSING ENDCAP
3	10	321-134	HHCS, 1/4-28 x 5/8 LG	11	1	722-005	ELBOW, 1/4 NPT x 3/8 37°
4	10	363-001	SPLIT LOCKWASHER, 1/4	12	2	492-002	WHEEL
5	1	486-024	FLUID METER	13	2	362-005	FLAT WASHER, 1/2
6	1	711-079	NIPPLE, 1/2 NPT x 1/4 NPT	14	2	355-011	HEX LOCKNUT, 1/2-13
7	1	PF101161	FILTER HOUSING	15	1	PF55447	FILLPORT ASSEMBLY
8	1	481-006	FILTER ELEMENT				

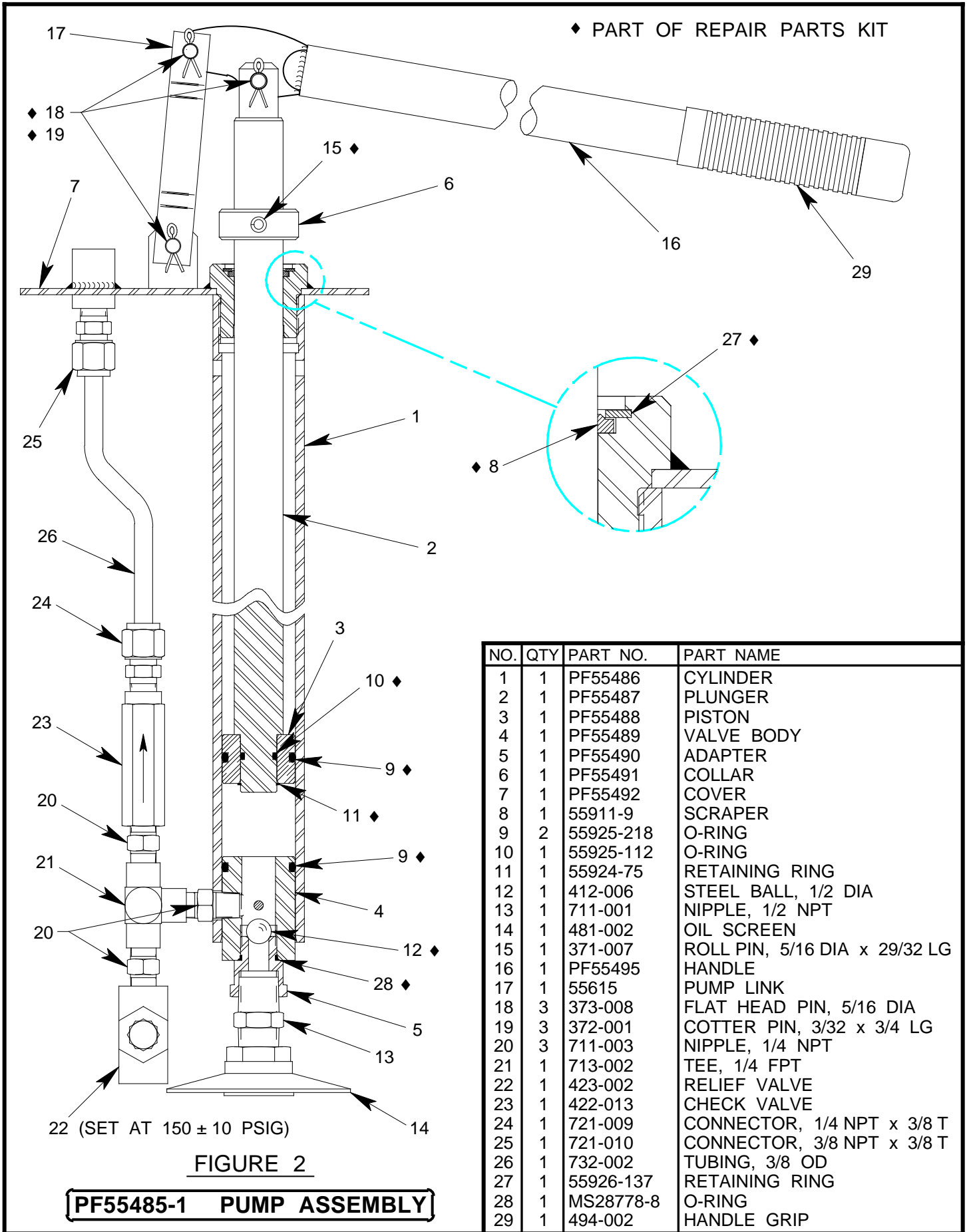

PF15-2PK REPAIR PARTS KIT

QTY	PART NO.	PART NAME
1	PF55456	HOSE ASSEMBLY
1	PF53456	GASKET
1	481-006	FILTER ELEMENT
1	55925-025	O-RING
1	55911-9	SCRAPER
2	55925-218	O-RING
1	55925-112	O-RING
1	55924-75	RETAINING RING
1	412-006	STEEL BALL, 1/2 DIA
1	371-007	ROLL PIN, 5/16 DIA x 29/32 LG
3	373-008	FLAT HEAD PIN, 5/16 DIA
3	372-001	COTTER PIN, 3/32 DIA x 3/4 LG
1	55926-137	RETAINING RING
1	MS28778-8	O-RING
1	PF15-2PKDOC	REPAIR PARTS KIT LIST