

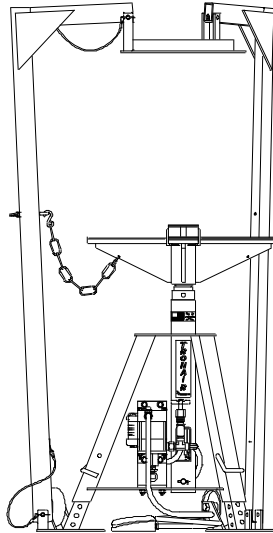

OPERATION & SERVICE MANUAL



Model: 14B6801-0120 Hydraulic Beadbreaker with Air Pump

10/2004 - Rev. 01

REVISION
01

DATE
01/2004

TEXT AFFECTED
Original Release



TABLE OF CONTENTS

PAGE

1.0	GENERAL DESCRIPTION	1
2.0	TECHNICAL SPECIFICATIONS.....	1
3.0	PREPARATION FOR USE	1
4.0	OPERATION	1
4.1	BOLTED/SPLIT WHEEL ASSEMBLIES	1
4.2	GOODYEAR WHEEL WITH De-mountable FLANGE (<i>Disassembly</i>).....	2
4.3	GOODYEAR WHEEL WITH De-mountable FLANGE (<i>Assembly</i>).....	3
5.0	MAINTENANCE.....	3
6.0	OPTIONAL TIRE RINGS	3
7.0	PROVISION OF SPARES.....	4
7.1	SOURCE OF SPARE PARTS.....	4
7.2	RECOMMENDED SPARE PARTS LISTS	4
8.0	GUARANTEES/LIMITATION OF LIABILITY	4
9.0	APPENDICES	4

This product can not be modified without the written approval of Tronair, Inc. Any modifications done without written approval voids all warranties and releases Tronair, Inc., its suppliers, distributors, employees, or financial institutions from any liability from consequences that may occur. Only Tronair OEM replacement parts shall be used.

1.0 GENERAL DESCRIPTION

The Tronair Hydraulic Beadbreakers are an easy-to-use device for breaking the tire bead from rims of up to 19 inches in diameter. It is also a handy assembly tool that will reduce the tire side wall height while assembling the rim assembly.

This tire beadbreaker is especially suited for breaking down and building up the Goodyear forged aluminum wheel with demountable flange (split ring) currently used on the Sabre 65 and Grumman III aircraft.

2.0 TECHNICAL SPECIFICATIONS

- Construction: All steel welded frame and members.
- Power Source: 2 1/4 Ton hydraulic force, air operated pump.
- Capacity: Rim sizes from five inches (5") to 19 inches, O.D.
- Ring Sizes: Ordered separately, see section 6.0 Optional Tire Rings
- Pump Rating: 8800 PSI

3.0 PREPARATION FOR USE

1. Refer to the Illustrated Parts Lists in this manual.
2. The Hydraulic Beadbreaker is shipped fully assembled and ready to use. Remove all packaging material and discard.
3. Check reservoir fluid level; allow no more than one-eighth inch (1/8") down.
4. Customer is to supply a shop air connection (1/8 NPT) to pneumatic foot switch.

NOTE: *The type of hydraulic fluid is MIL-H-5606.*

4.0 OPERATION

WARNING!



- **ALWAYS follow the wheel manufacturer's instructions and procedures relative to their respective products.**
- **DO NOT attempt to disassemble wheel until tire has been completely deflated; otherwise, serious injury to personnel or damage to equipment can result.**
- **DO NOT attempt to remove valve core until tire has been completely deflated. Valve cores will be ejected at high velocity if unscrewed before air pressure has been released.**

4.1 BOLTED/SPLIT WHEEL ASSEMBLIES

To break the tire bead on this type of wheel assembly:

1. Deflate the tire and remove the valve core.
2. Select the proper tire ring.
3. Adjust the mechanical leg extensions so that the tire/wheel assembly is within approximately two inches (2") of the tire ring or at its maximum height.



CAUTION!

- **Do not go beyond the last hole in the extension tube.**
- **Extend mechanical leg extensions equally; wheel support must be level.**

4. Place tire/wheel assembly onto the wheel support and center.

NOTE: *Depending on the wheel configuration, the movable support pads may be or may not be required. If not required, slide the three support pads to the middle of the wheel support so they are out of the way.*



CAUTION!

The wheel rim must rest solidly on either the wheel support proper or on the support pads.

5. Open the air valve (Item 14) and close the hydraulic relief valve (Item 25) on the beadbreaker unit. When the pneumatic foot switch (Item 37) is actuated, the beadbreaker piston will raise the tire/wheel assembly. As the tire nears contact with the tire ring, center the tire ring around the wheel.



CAUTION!

The tire ring and wheel must have at least one-quarter inch (1/4") clearance and must have come in contact with the wheel proper.

6. Continue lifting tire/wheel assembly until the tire bead breaks loose from the wheel assembly.
7. Lower the tire/wheel assembly by closing the air valve (Item 14) and opening the hydraulic relief valve (Item 25) on the beadbreaker unit. Flip tire/wheel assembly and repeat Steps 4 through 6.

4.0 OPERATION *(continued)***4.2 GOODYEAR WHEEL WITH De-mountable FLANGE** *(Disassembly)*

To break the tire bead on this type of wheel assembly:

1. Deflate the tire and remove the valve core.
2. Select the proper tire ring.
3. Adjust the mechanical leg extensions so that the tire/wheel assembly is within approximately two inches (2") of the tire ring or at its maximum height.

**CAUTION!**

- **Do not go beyond the last hole in the extension tube.**
- **Extend mechanical leg extensions equally; wheel support must be level.**

4. Place tire/wheel assembly onto the wheel support and center.
5. Slide the support pads under the wheel rim.

**CAUTION!**

The wheel rim must rest solidly on the support PADS.

6. Open the air valve (Item 14) and close the hydraulic relief valve (Item 25) on the beadbreaker unit. When the pneumatic foot switch (Item 37) is actuated, the beadbreaker piston will raise the tire/wheel assembly. As the tire nears contact with the tire ring, center the tire ring around the wheel.

**CAUTION!**

The tire ring and wheel must have at least one-quarter inch (1/4") inch clearance and must never come in contact with the wheel proper.

7. Continue lifting tire/wheel assembly until the tire bead has broken loose from the wheel de-mountable flange and the de-mountable flange has shifted downward exposing the wheel split ring and clip.
8. Remove the wheel split ring.
9. Lower the tire/wheel assembly by closing the air valve (Item 14) and opening the hydraulic relief valve (Item 25) on the beadbreaker unit.
10. Remove the wheel de-mountable flange if possible. If still tight on the wheel, carefully flip the tire/wheel assembly on the wheel support and re-center.

NOTE: The support pads must now be relocated.

CAUTION!

- **The support pads must be located beneath the wheel rim.**
- **Assure clearance between the rim O.D. and the de-mountable flange to pass without contacting the support pads.**

11. Using the beadbreaker hydraulics, lift the tire/wheel assembly. As the tire nears contact with the tire ring, center the tire ring around the wheel.

**CAUTION!**

The tire ring and wheel must have at least 1/4 inch clearance and must never come in contact with the wheel proper.

12. Continue lifting the tire/wheel assembly until both the tire bead has been broken loose from the wheel assembly and the de-mountable flange has been pushed off the O-ring; should be resting on the wheel support proper.
13. Lower the tire/wheel assembly by closing the air valve (Item 14) and opening the hydraulic relief valve (Item 25) on the beadbreaker unit. Carefully remove the component parts.

4.0 Operation continued on the following page.

4.0 OPERATION (continued)**4.3 GOODYEAR WHEEL WITH De-mountable FLANGE** (Assembly)

To install a tire on this wheel assembly:

1. Remove two (2) of the three (3) pins holding the tire ring in place and flip the ring out of the way.
2. Place the wheel on the wheel support and center.

NOTE: The support pads are not required here and should be slid to the middle of the wheel support.

**CAUTION!**

The wheel rim must rest solidly on the wheel support.

3. Install tire onto wheel following manufacturer's instructions for alignment.
4. Re-install the tire ring.
5. Open the air valve (Item 14) and close the hydraulic relief valve (Item 25) on the beadbreaker unit. When the pneumatic foot switch (Item 37) is actuated, the beadbreaker piston will raise the wheel and compress the tire. The tire ring must be centered on the tire.
6. Complete the installation of the beadbreaker ring, de-mountable flange, split ring, retaining clip and safety wire per manufacturer's instructions.
7. Lower the tire/wheel assembly by closing the air valve (Item 14) and opening the hydraulic relief valve (Item 25) on the beadbreaker unit. Remove from the wheel support.

5.0 MAINTENANCE

Periodically perform a visual inspection of the beadbreaker assembly. Repair or replace suspect parts.

Maintain the correct hydraulic oil level in the pump reservoir. Reference **3.0 Preparation for Use**.

6.0 OPTIONAL TIRE RINGS

The following table is a listing of available tire rings for use on tires. To determine the ring size you require, add 0.55 inches to the wheel maximum O.D. then round this number to the next higher whole number.

SIZING (inches)	WITHOUT CHINES	WITH CHINES
6	Z-1063-06	Z-1064-06
7	Z-1063-07	Z-1064-07
8	Z-1063-08	Z-1064-08
9	Z-1063-09	Z-1064-09
10	Z-1063-10	Z-1064-10
11	Z-1063-11	Z-1064-11
12	Z-1063-12	Z-1064-12
13	Z-1063-13	Z-1064-13
14	Z-1063-14	Z-1064-14
15	Z-1063-15	Z-1064-15
16	Z-1063-16	Z-1064-16
17	Z-1063-17	Z-1064-17
18	Z-1063-18	Z-1064-18
19	Z-1063-19	Z-1064-19
20	Z-3072-20	Z-1064-20
21	Z-3072-21	--
22	Z-3072-22	-

EXAMPLE: For a wheel O.D. of 11.62 inches, the calculation is as follows:

STEP 1. 11.62 inches (Maximum wheel O.D.)
 + 0.55 (Tronair standard size factor)
 = 12.17

STEP 2. Rounding to next whole number = 13

STEP 3. A "sizing" number of 13 dictates a Z-106X-13 tire ring.



7.0 PROVISION OF SPARES

7.1 SOURCE OF SPARE PARTS

Spare parts may be obtained from the manufacturer:

TRONAIR, Inc.

1 Air Cargo Pkwy East

Swanton, Ohio 43558 USA

Telephone: (419) 866-6301 or 800-426-6301

Fax: (419) 867-0634

E-mail: sales@tronair.com

Website: www.tronair.com

7.2 RECOMMENDED SPARE PARTS LISTS

Reference the following page(s) for Replacement Parts and Kits available.

8.0 GUARANTEES/LIMITATION OF LIABILITY

Tronair products are warranted to be free of manufacturing or material defects for a period of one year after shipment to the original customer. This is solely limited to the repair or replacement of defective components. This warranty does not cover the following items:

- a) Parts required for normal maintenance
- b) Parts covered by a component manufacturers warranty
- c) Replacement parts have a 90-day warranty from date of shipment

If you have a problem that may require service, contact Tronair immediately. Do not attempt to repair or disassemble a product without first contacting Tronair, any action may affect warranty coverage. When you contact Tronair be prepared to provide the following information:

- a) Product Model Number
- b) Product Serial Number
- c) Description of the problem

If warranty coverage is approved, either replacement parts will be sent or the product will have to be returned to Tronair for repairs. If the product is to be returned, a Return Material Authorization (RMA) number will be issued for reference purposes on any shipping documents. Failure to obtain a RMA in advance of returning an item will result in a service fee. A decision on the extent of warranty coverage on returned products is reserved pending inspection at Tronair. Any shipments to Tronair must be shipped freight prepaid. Freight costs on shipments to customers will be paid by Tronair on any warranty claims only. Any unauthorized modification of the Tronair products or use of the Tronair products in violation of cautions and warnings in any manual (including updates) or safety bulletins published or delivered by Tronair will immediately void any warranty, express or implied.

The obligations of Tronair expressly stated herein are in lieu of all other warranties or conditions expressed or implied. **Any unauthorized modification of the Tronair products or use of the Tronair products in violations of cautions and warnings in any manual (including updates) or safety bulletins published or delivered by Tronair will immediately void any warranty, express or implied and Tronair disclaims any and all liability for injury (WITHOUT LIMITATION and including DEATH), loss or damage arising from or relating to such misuse.**

9.0 APPENDICES

APPENDIX I Haskel MLP-20/46D Technical Specifications & Performance Data, Drawings 28550

Parts List

When ordering replacement parts/kits, please specify model, serial number and color of your unit.

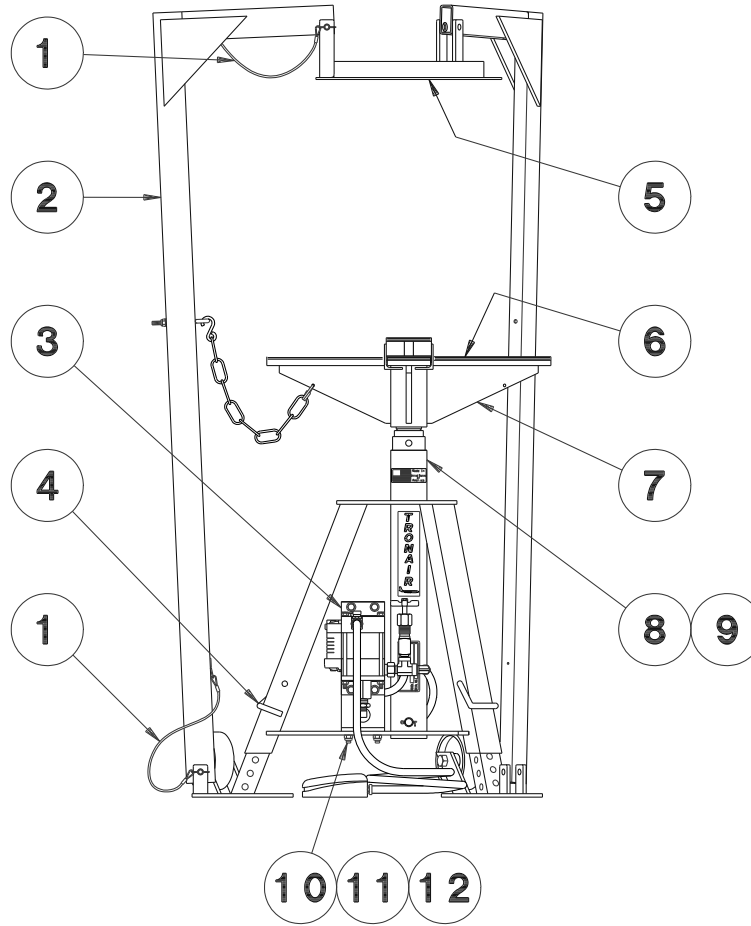

Item	Part Number	Description	Qty
2	Z-1069-01	Weldment, Arm	3
4	G-1311-01	Pin, Lock	3
5	See 6.0 Optional Tire Rings	Weldment, Tire Ring	1
8	HC-1683-01	Cylinder, Replacement	1
10	G-1100-106510	Bolt, Hex Head, Grade 5, 5/16-24 x 1" long	Ref
11	G-1250-1060N	Flatwasher, 5/16 Narrow	Ref
12	G-1202-1065	Stopnut, 5/16-24 Elastic	Ref
1	K-2377	Kit, Replacement Pin; consists of:	
	G-1307-0618	'C' Pin, 3/8" x 1.8" long	1
	G-1351-04	Rivet, 1/8" Open-End Steel	1
	H-1026*12.0	Assembly, Lanyard	1
6	K-2378	Kit, Support Pad; consists of:	
	Z-1073	Weldment, Support Pad	1
	H-1023	Neoprene Padding	1
7	K-2379	Kit, Wheel Support; consists of:	
	Z-1066-01	Weldment, Support	1
	H-1022	Neoprene Padding	1
9	K-2513	Kit, Cylinder Seal; consists of:	
	HK-2513	Kit, Seal Repair	1

Parts List

When ordering Replacement Parts/Kits, please specify Model, Color and Serial Number of your Unit

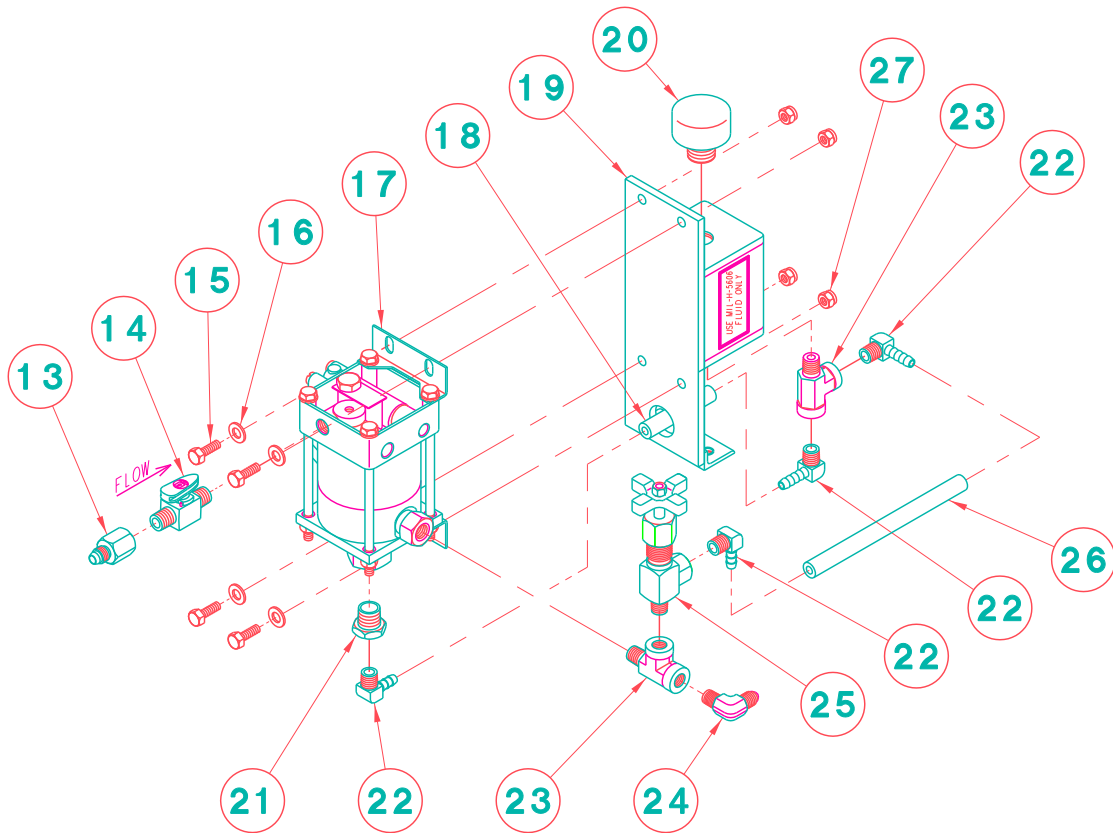

Item	Part Number	Description	Qty
	K-3721	Kit, Air Pump ; consists of:	
10	G-1100-106510	Bolt, Hex Head, Grade 5, 5/16-24 x 1" long	2
11	G-1250-1060N	Flatwasher, 5/16 Narrow	2
12	G-1202-1065	Stopnut, 5/16-24 Elastic	2
13	N-2010-04-S	Connector, Female	1
14	H-1173	Valve, Plug	1
15	G-1100-105506	Bolt, Hex Head, Grade 5, 1/4-28 x 3/4" long	4
16	G-1250-1050N	Flatwasher, 1/4 Narrow	4
17	H-2796	Pump, Air	1
18	TF-1047-01*03.0	Hose, 1/4" Grey	1
19	Z-3281-01	Weldment, Bracket	1
20	H-1045	Breather	1
21	N-2210-05-S	Reducer, Pipe Thread	1
22	N-2410-02	Elbow, 90° Male	4
23	N-2209-03-S	Tee, Street	2
24	N-2005-04-S	Elbow, 90° Male	1
25	HC-1101-01	Valve, Needle	1
26	TF-1047-01*08.0	Hose, 1/4" Grey	1
27	G-1202-1055	Stopnut, 1/4-28 Elastic	4

Parts List

When ordering Replacement Parts/Kits, please specify Model, Color and Serial Number of your Unit

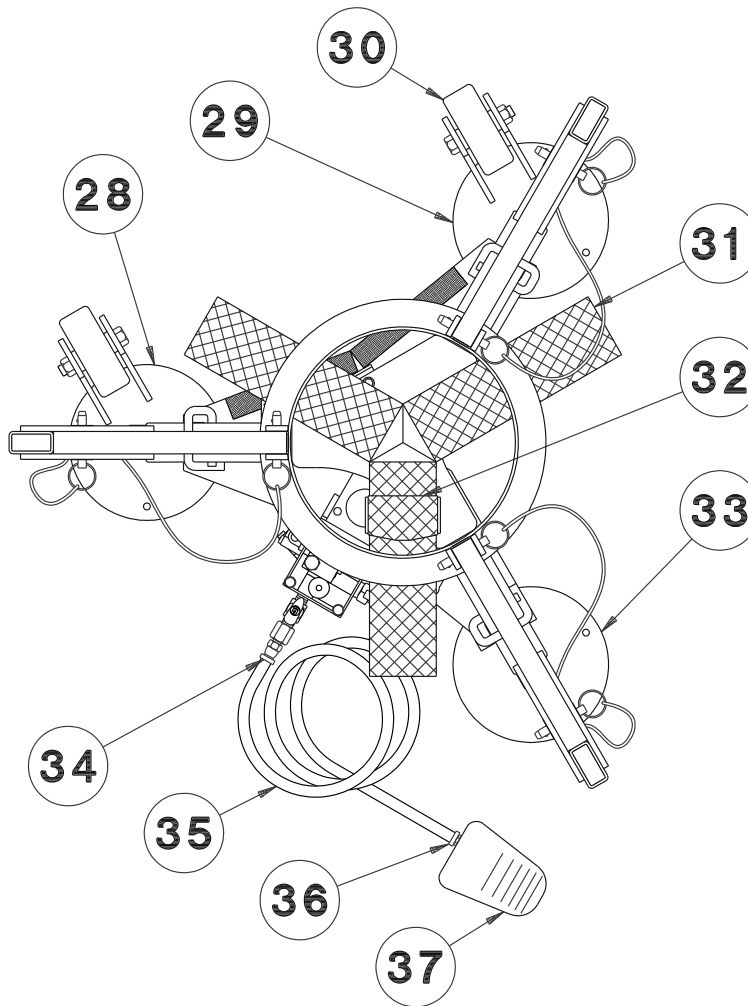

Item	Part Number	Description	Qty
28	Z-1136-02-01	Weldment, Leg Set	1
29	Z-1136-03-01	Weldment, Leg Set	1
31	H-1022	Pad, Neoprene	3
32	H-1023	Pad, Neoprene	3
33	Z-1136-01-01	Weldment, Leg Set	1
30	K-1165	Kit, Replacement Wheel ; consists of:	
	U-1002	Wheel	2
	G-1203-1095	Jamnut, 1/2-20 Elastic	2
	G-1100-109526	Bolt, Hex Head, Grade 5, 1/2-20 x 2 3/4" long	2
	K-2546	Kit, Foot Valve ; consists of:	
34	N-2026-01-S	Swivel, 37° JIC	1
35	TF-1047-01*72.0	Hose, 1/4" Gray	1
36	N-2412-04	Connector, Straight Male	1
37	PC-1066	Valve, Pneumatic Foot	1



APPENDIX I

Haskel Air Pump Manufacturer Data



PNEUMATIC DRIVEN LIQUID PUMPS

PERFORMANCE • QUALITY • RELIABILITY

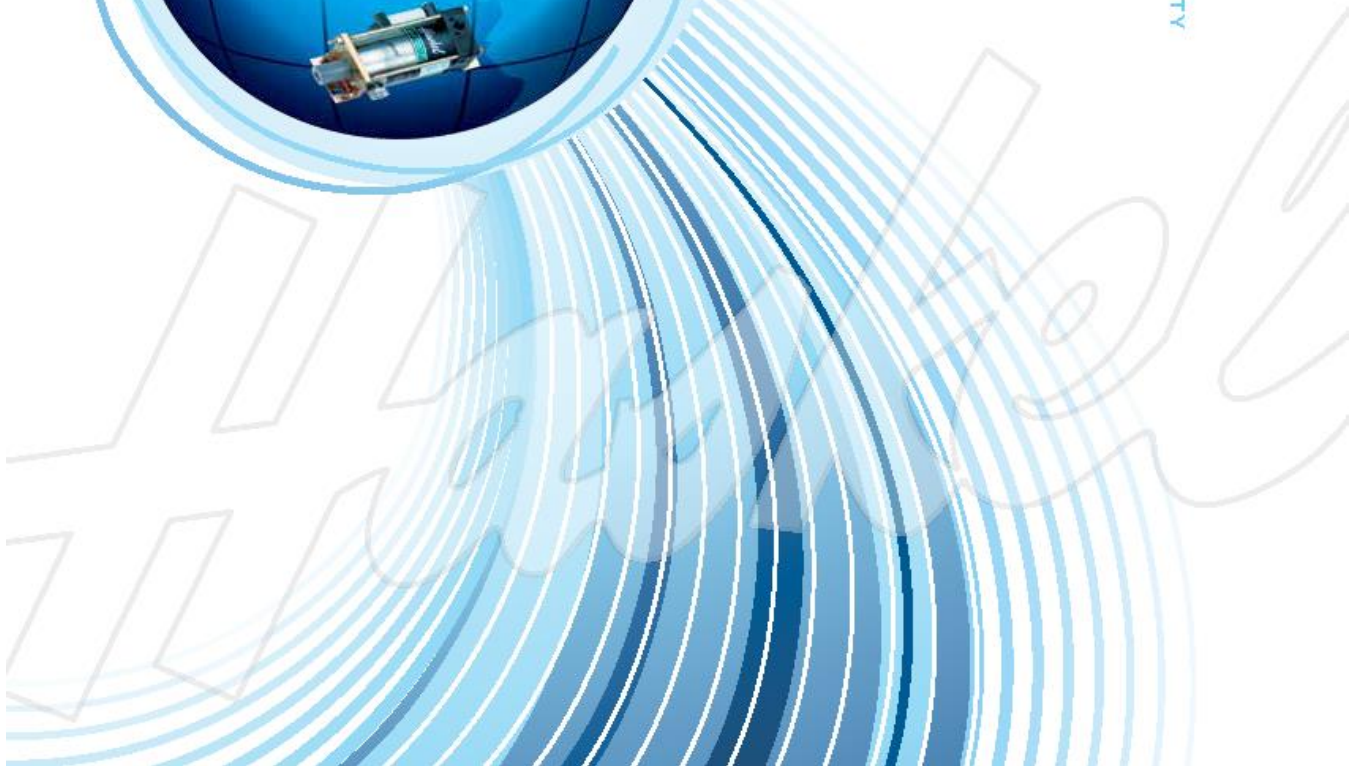



Welcome to Haskel

Haskel is an international organization offering a worldwide service through the Haskel group of companies and factory trained distributors. The Haskel group is headquartered in Burbank, California, with facilities throughout the world. We have built an enviable reputation for quality based on high pressure fluid and gas handling equipment.

In addition to offering a comprehensive range of pneumatic driven liquid pumps, air amplifiers, pneumatic and hydraulic driven gas boosters, high pressure valves, fittings and accessories, we custom design and build power pacs and test rigs. Our continued investment in technology ensures that Haskel will stay at the leading edge of high pressure technology.

This brochure introduces our pneumatic driven liquid pump range. Technical details and advice on any of the products shown is available on request.

We are here to solve your problems. Just give us a call at 818-843-4000 or visit our website at www.haskel.com for more information or to locate a distributor.

Why Use Haskel Pneumatic Driven Pumps?

Our pumps offer many advantages over electrically driven pumps:

- Safe pneumatic operation – no heat, flame or spark risk
- Up to 100000 psi (7000 bar) capability
- Infinitely variable cycling speed
- Stall feature at pre-determined pressure to hold that pressure without consuming power
- Problem-free stop/start applications
- Easily automated – many modification and control options
- Suitable for most liquids and liquefied gases
- Alternative gas drive options – sour gas, natural gas, boil off gases, nitrogen
- No need for air line lubrication – saves costs and prevents contamination
- Robust, reliable, compact and easy to maintain proven design
- Unbalanced cycling spool provides immediate response to pressure changes
- Also available in standard, or custom built power pac configurations
- Excellent worldwide service for spares and repairs
- Can be manufactured to meet API 675, ATEX, CE and NACE

Applications include:

- Pressure testing
- Work holding/power clamping
- Jacking/lifting
- Valve actuator control
- Hydraulic cylinder actuation
- Press safety overload devices
- Roller tensioning
- Metering
- Precision lubrication and spraying
- Liquefied gas transfer



Pressure and Flow on Demand

This guide will help you to pre-select the pump ideally suited for your application. If you have specific questions, however, we urge you to provide us with details of the duties you require from the pump, available air/gas drive pressure, and pressure/flow requirements, and we will recommend a model and any corresponding accessories.

Output Horsepower Ratings

The pumps are categorized on their horsepower ratings (see pages 6-7). These are approximate and peak at 100 psi (7 bar), assuming adequate drive air, pressure and volume. Peak horsepower is at about 75% nominal ratio x air drive pressure, i.e. 100:1 pump @ 100 psi air drive peaks at $100 \times 100 = 10000 \times 0.75$ psi = 7500 psi (517 bar) hydraulic pressure.

Operation

The pumps automatically reciprocate on a differential piston principle. A large piston driven by relatively low pressure drive acts directly upon a smaller hydraulic piston.

The nominal ratio between piston sizes is indicated in the model coding and approximates to the maximum working pressure. The actual ratio is about 15% above nominal so that the pump continues to cycle when drive pressure equals nominal ratio. Initially, the pump will cycle at maximum speed acting as a transfer pump to pressurize downstream.

It will cycle at a slower rate as the fluid meets resistance until it stalls at maximum output pressure. When a pressure drop downstream occurs, it will recycle as necessary in an effort to maintain maximum pressure. Stall pressure is achieved when the outlet pressure rises and offers more resistance to the reciprocating differential piston assembly. The piston assembly then stalls when the forces balance, e.g. when drive pressure x drive piston area equals outlet (stall) pressure x driven hydraulic plunger area. The pump design is sensitive to very small pressure drops due to the low frictional resistance of the large diameter drive piston and hydraulic piston seals.

Double and Triple Air Head Pumps

Performance can be extended by stacking air pistons without changing the hydraulic piston. Haskel multi-head pumps consume less air than competitive single head pumps of the same area, as only one head is pressurized on the return stroke; e.g., on a 1.5 hp pump additional heads can raise performance to 2 hp.

Double air head pumps are identified by the last digit 2 in the pump model number. Thus, a nominal 50:1 ratio pump with two air heads is described as a 52. Similarly, a triple air head pump is identified with a last digit 3. Thus, a 900 ratio pump with three air heads is described as a 903.

Single Drive Head Pump

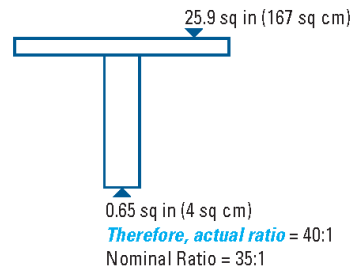

Double Air Head Pump

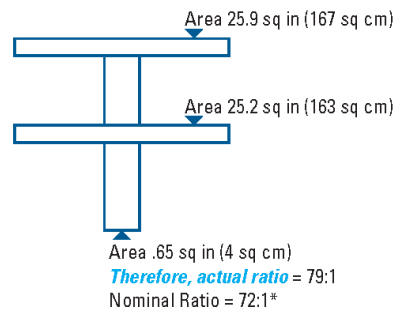

Triple Air Head Pump

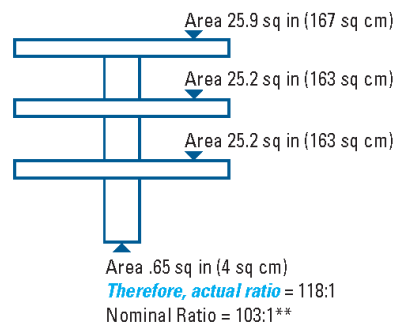

Nominal Ratio

* (2) Indicates Double Drive Piston

** (3) Indicates Triple Drive Piston

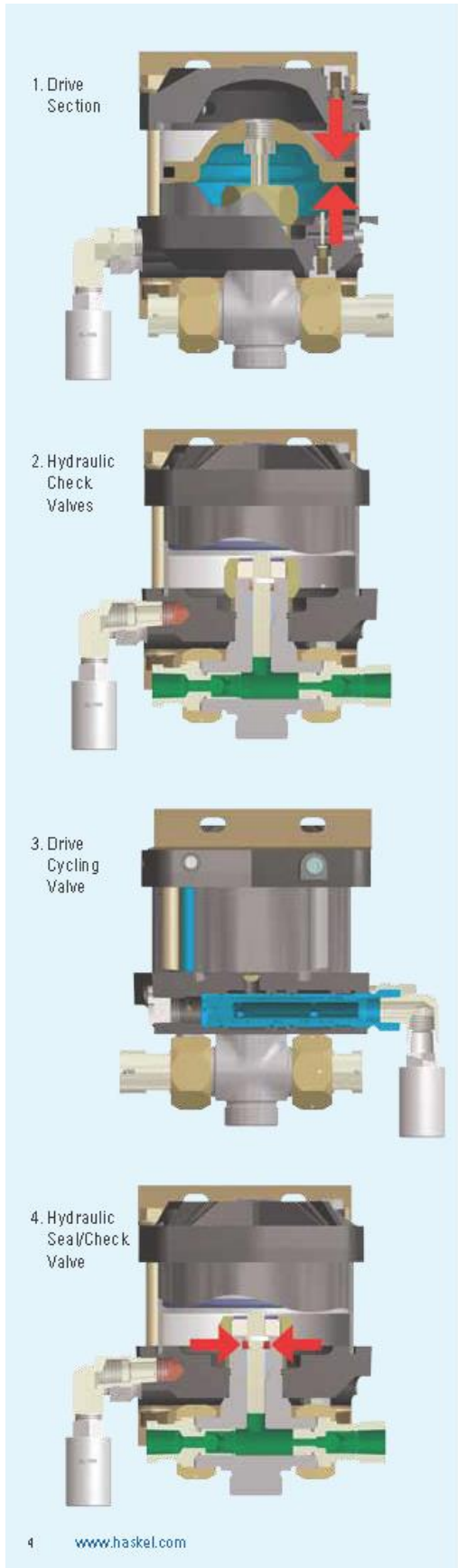

Anatomy of a Pneumatic Driven Pump

1. Drive Section

The piston, complete with "O" ring seal, operates in an epoxy filled, fiberglass wound barrel, the diameter of which is constant throughout a given series of pumps. Drive media forces the piston down on the compression stroke and raises it on the suction stroke (M series have a spring return). The piston is pre-lubricated during assembly and therefore no air line lubricator is necessary.

2. Hydraulic Section/Check Valves

This is directly linked to the drive piston by the hydraulic piston, the bottom portion of which is in the hydraulic body. Outlet flow and pressure are determined by the area of the hydraulic piston head, its nominal ratio with the drive piston head, and drive pressure. On the down stroke, liquid in the hydraulic section is forced under compression through the outlet check valve. Fresh liquid is induced via the inlet check valve on the return stroke. These check valves control the flow of liquid through the hydraulic section. They are spring-loaded and have a very low cracking pressure, allowing maximum opening on the induction stroke. The pressure of hydraulic fluid on the down stroke closes the inlet check valve and acts against the spring to open the outlet check valve.

3. Drive Cycling Valve

This is a pilot-operated, unbalanced, lightweight spool, which directs drive pressure, first to the top of the drive piston, and then to the underside to reciprocate the piston (cycle). It actuates via pilot valves at the top and the bottom of the stroke, which causes the unbalanced spool to shift and reciprocate the piston.

4. Hydraulic Seal/Check Valves

This is one of the few wear parts. Its function is to allow the hydraulic piston to reciprocate without passing fluid into the drive section. The liquid, its pressure and its temperature determine seal specification. A distance piece can be incorporated between drive and hydraulic sections for complete contamination-free operation on most Haskel pumps.



Pump Selection Information

All Haskel pumps are identified by letters coding the type of pump, followed by a number indicating the practical working ratio

of the drive area to the hydraulic plunger area. These letters are explained in the chart below.

Pump Model Letter Coding

M	.875" stroke .33 hp miniature pump series	XH	2" stroke 1.5 + 2 hp Extreme High Pressure pump series
S	Stainless steel hydraulic piston and body	G	4.5" stroke 6 hp pump series
29723	.33 hp Chemical Pump	8	4.5" stroke 8 hp pump or booster series
D (Prefix)	Pump incorporates a Distance Piece	14	4" stroke 10 hp pump series
D (Suffix)	Double Acting pump	W	Polyurethane U-cup dynamic seal
4B	1" stroke .75 hp pump series (bottom inlet only)	F	UHMWPE (Ultra-high Molecular Weight Polyethylene Dynamic Seal
A	2" stroke 1.5 + 2 hp pump series	T	Reinforced teflon dynamic seal
H	2" stroke 1.5 + 2 hp High Pressure pump series	V	Viton o-ring static seal
-C	Filter, regulator with gauge and shut-off/speed control valve	-B	Bottom inlet
		-CP	Chemical Pump

Quick Model Comparison Chart

The chart to the right shows the pressure/flow capability of each pump in the range. The diagonal lines show constant output horsepower for each series. The model ratios are circled.

Example

The pressure required is 2175 psi (150 bar). The flow required is 215 cubic inches (3.52 liters) per minute. The black dot plots position. Only models on diagonals to the right of the dot will meet the demand; e.g., the -35 ratio 1.5 hp pump, assuming a supply at 100 psi (7 bar) and 70 scfm (119m³/hr) can be met; if not, a -32 or -52 2 hp pump would be needed.

The diagonal horsepower lines in the chart below are based on 100 psi (7 bar) drive pressure. Drive flow requirement is different for each series as follows:

.33 hp	15 scfm (25 m ³ /hr)	3 hp	85 scfm (144 m ³ /hr)
.75 hp	45 scfm (76 m ³ /hr)	6 hp	175 scfm (297 m ³ /hr)
1.5 hp	70 scfm (119 m ³ /hr)	8 hp	225 scfm (382 m ³ /hr)
2 hp	85 scfm (144 m ³ /hr)	10 hp	270 scfm (459 m ³ /hr)

Reduced air drive flow or pressure will result in a corresponding reduction in output horsepower. This chart can be used to select pump series and model ratio.

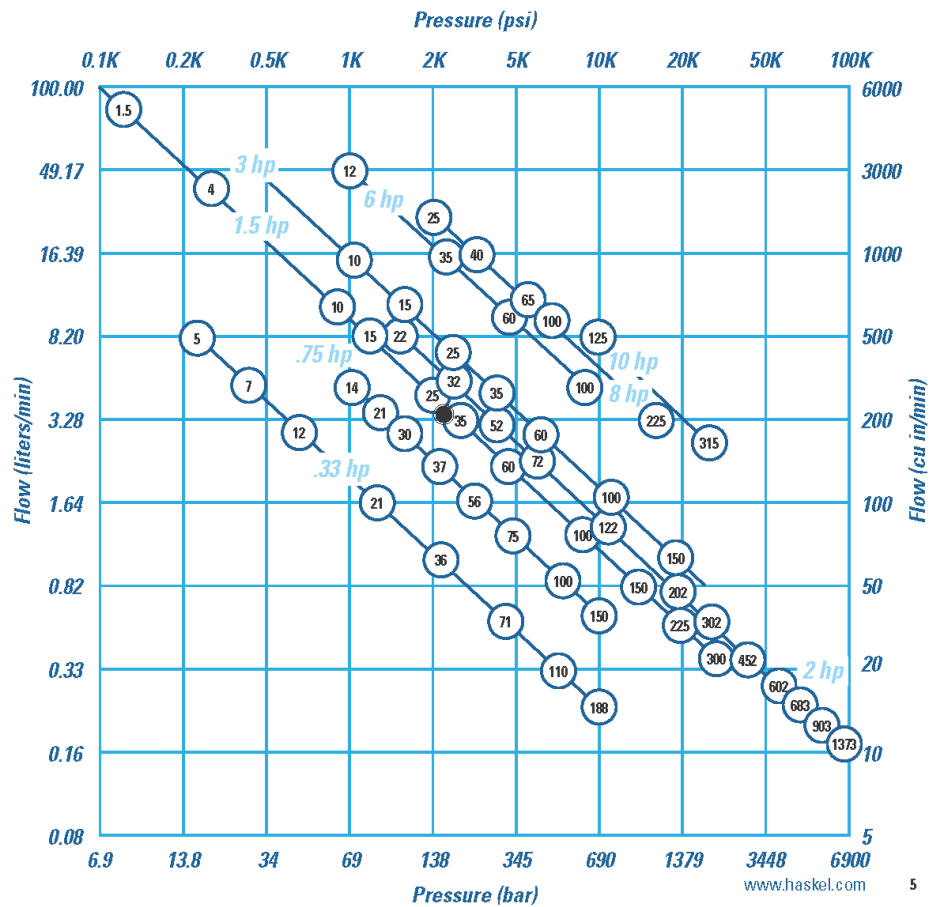

Note: For specific performance curves, refer to Liquid Pump Rapid Reference Guide.

Performance and Specification Overview

Max Drive Drive Head HP	Pump Model Code	Nominal Ratio	Actual Ratio	Mainimum Rated Output Pressure				Displacement/Cycle		Maximum Flow	
				Continuous		Intermittent		cu in	ml	cu in/min	l/min
				psi	bar	psi	bar				
125 psi/8.6 bar Single 0.33 hp	M, MDSTV	-5	5.6	625	43	625	43	0.83	13.6	506	8.30
	M, MS	-7	7.8	900	62	900	62	0.60	9.8	366	6.00
		-12	14	1500	103	1500	103	0.36	5.9	234	3.83
	M, MS, 29723	-21	25	2600	179	2600	179	0.20	3.3	130	2.13
		-36	41	4500	310	4500	310	0.12	2.0	78	1.28
		-71	82	8800	607	8800	607	0.060	1.0	39	0.64
		-110	126	13500	931	13500	931	0.039	0.6	25	0.42
		-188	217	15000	1034	15000	1034	0.023	0.4	18	0.29
	MS	-220	237	20000	1380	25000	1723	0.021	0.344	14	0.22
100 psi/7 bar Single 0.75 hp		-14	16	1500	103	1500	103	0.90	14.7	428	7.01
		-21	24	2300	159	2300	159	0.60	9.8	285	4.67
		-25	29	2700	186	2700	186	0.50	8.2	238	3.89
	4B	-30	34	3200	221	3200	221	0.43	7.0	204	3.35
		-37	42	3800	262	3800	262	0.35	5.7	166	2.72
		-55	63	6000	414	6000	414	0.22	3.6	105	1.71
		-75	86	7800	538	7800	538	0.17	2.8	81	1.32
		-100	114	10600	731	10600	731	0.13	2.0	62	1.01
		-150	171	15000	1034	15000	1034	0.088	1.44	42	0.68
	150 psi/10.5 bar Single 1.5 hp	DSTV	-1.5	1.6	120	8	160	11	31.90	513	5104
ATV, DTV		-4	80	690	48	1200	83	20.00	328	3200	52.4
		-B10	11.5	1600	110	1600	110	4.05	66.4	1215	19.9
		-B15	17	2400	165	2400	165	2.70	44.3	810	13.3
AW, ASF, DF, DSF, DSTV		-25	29	4000	276	4000	276	1.62	26.6	486	8.0
		-35	40	5700	393	5700	393	1.16	19.0	348	5.7
		-60	69	9800	676	9800	676	0.67	11.0	201	3.3
		-100	115	15000	1034	16500	1138	0.41	6.7	123	2.0
		-150	173	15000	1034	20000	1380	0.27	4.5	81	1.3
		-151	173	25000	1724	25000	1724	0.27	4.5	81	1.3
HF, HSF, DHF, DSHF		-225	260	30000	2069	37000	2551	0.18	3.0	41	0.7
		-300	345	30000	2069	50000	3448	0.14	2.3	32	0.5
HF	-450	533	25000	1724	45000	3403	0.091	1.5	20	0.3	
150 psi/10.5 bar Double 2 hp		-B22	23	3200	221	3200	221	4.05	66.4	1215	19.9
		-B32	34	4800	331	4800	331	2.70	44.3	810	13.3
	AW, ASF, DF, DSF, DSTV	-52	57	5000	345	8000	552	1.62	26.6	486	8.0
		-72	80	11000	758	11000	758	1.16	19.0	348	5.7
		-122	138	15000	1034	19000	1310	0.67	11.0	201	3.3
	HF, HSF, DHF, DSHF	-202	230	30000	2069	33000	2275	0.41	6.7	92	1.5
		-302	346	30000	2069	50000	3448	0.27	4.5	61	1.0
	DXHF, DSXHF	-452	520	30000	2069	70000	4827	0.18	3.0	41	0.7
	-602	690	30000	2069	75000	5171	0.14	2.3	32	0.5	
100 psi/7 bar Triple 2 hp	DXHF, DSXHF	-683	780	30000	2069	70000	4827	0.18	3.0	25	0.41
		-903	1038	30000	2069	75000	5171	0.14	2.3	20	0.33
	DSXHW	-1373	1575	30000	2069	100000	6895	0.086	1.4	12	0.197
100 psi/7 bar 2.2	AFD, DFD, ASFD, DSFD	-B60	69	6500	448	6500	448	1.34	2.2	369	6.0
		-10	11.5	1600	110	1600	110	8.10	133	1823	29.9
150 psi/10.5 bar 3 hp		-15	17	2400	165	2400	165	5.40	89	1215	19.9
	ASFD	-25	29	4000	276	4000	276	3.24	53.2	729	11.9
		-35	40	5700	393	5700	393	2.32	38.0	522	8.6
		-60	69	9800	676	9800	676	1.34	22.0	302	4.9
		-100	115	15000	1034	16500	1138	0.82	13.4	185	3.0
		-150	173	15000	1034	20000	1380	0.54	9.0	122	2.0
		-202	230	30000	2069	33000	2275	0.32	13.4	144	2.4
125 psi/8.6 bar Single 6 hp	GWD, GSFD, DGF, DGSFD, DGSTVD	-12	14.8	1850	128	4000	276	15.9	260	5009	82.1
		-35	40.3	4375	302	4375	302	6.0	98	1890	31.0
	GW, DGF, GSF, DGSF, DGSTV	-60	69	7500	517	7500	517	3.5	57	1103	18.1
		-100	115	8000	552	10000	690	2.1	34	662	10.8
125 psi/8.6 bar 8 hp	8SFD, 8DSFD, 8DSTVD	-25	27.5	3575	246	4000	276	14.0	229	2660	44
		-40	43.5	6000	414	6000	414	8.90	145	1691	28
	8SFD	-65	73	10000	690	10000	680	5.40	88	1026	17
	8DSFD	-100	112	10000	690	10000	680	3.52	57.5	669	11
	8HSFD	-225	253	22500	1530	22500	1530	1.56	25.5	296	5
10 hp	D14STD, D14SFD	-125	138	16000	1103	16000	1103	8.80	144	704	11.5
		-315	347	36000	2482	36000	2482	3.50	57.4	280	4.6

Typical Performance Based on 100 psi (7 bar) Pressure and Drive Flow Data on Page 5							
Outlet Pressure		Outlet Flow		Outlet Pressure		Outlet Flow	
psi	bar	cu in/min	l/min	psi	bar	cu in/min	l/min
225	15.5	500	8.20	415	29	249	4.09
300	21	350	5.70	600	41	160	2.60
700	48	200	3.28	1125	78	100	1.64
1500	103	90	1.48	2000	138	48.9	0.80
1700	117	70	1.15	3100	214	39.6	0.65
3000	207	39	0.64	6000	414	19	0.31
7500	517	20	0.33	8500	586	17	0.28
9000	345	18	0.30	10000	690	14	0.23
7500	517	14	0.23	15000	1034	12	0.20
700	48	400	6.55	1450	100	61	1
1000	69	270	4.42	2000	138	120	2
1250	86	230	3.77	2500	172	61	1
1500	104	200	3.28	3000	207	62	1
1750	121	170	2.78	3500	241	82	1.33
2000	138	110	1.8	5000	345	66	1.08
2500	172	87	1.42	7500	517	37	0.6
9000	345	57	0.93	10000	690	26	0.43
7500	517	37	0.6	15000	1034	7	0.11
50	3	5000	81.9	150	10.3	1000	16.4
100	7	1953	32	400	28	750	12.3
400	28	1000	16.4	990	68	500	8.19
750	52	598	9.8	1600	110	200	3.28
1000	69	403	6.6	2500	172	195	3.2
2000	138	350	4.1	3600	248	98	1.6
3000	207	152	2.5	6200	427	50	0.82
4000	276	100	1.64	10000	690	24.4	0.4
7000	483	59.7	0.98	15000	1034	29.9	0.49
7000	483	59.7	0.98	15000	1034	29.9	0.49
7500	517	39.6	0.65	24000	1655	9.8	0.16
15000	1034	29.9	0.49	27000	1862	20.1	0.33
36000	2483	14.6	0.24	45000	3103	9.2	0.15
400	28	799	13.1	2100	145	200	3.28
700	48	500	8.2	3000	207	152	2.5
1900	131	299	4.9	5000	345	97.6	1.6
2000	138	226	3.7	7500	517	50	0.82
4000	276	122	2	12000	828	40.2	0.66
7000	483	91.5	1.5	20000	1379	20.1	0.33
10000	690	45.2	0.74	30000	2069	15.2	0.25
10000	690	34.8	0.57	40000	2799	15.2	0.25
15000	1034	24.4	0.4	50000	3448	12.2	0.2
15000	1034	19.5	0.32	60000	4138	4.9	0.08
15000	1034	15.9	0.26	70000	4828	5.5	0.09
16000	1103	9.2	0.15	90000	6207	3.1	0.05
1000	69	348	5.7	5500	379	152	2.5
500	34	1520	24.9	1000	69	380	6.22
750	52	1030	16.88	1500	103	260	4.26
1000	69	662	10.85	2500	172	162	2.66
1500	104	465	7.62	3500	248	100	1.64
3000	138	248	4.07	6000	414	56	0.92
9000	345	151	2.48	10000	690	41	0.67
7500	517	103	2	15000	1034	27	0.44
10000	690	63	1.03	20000	1379	47	0.77
200	14	5004	82	1200	83	1494	24
1000	69	1770	29	3500	241	600	9.8
2000	138	976	16	5500	379	397	6.5
2000	138	573	9.4	10000	690	195	3.2
1000	69	2400	39.3	2500	172	280	4.6
2000	138	1420	23.2	4000	276	200	3.27
3000	207	880	14.4	6000	414	310	5.08
9000	345	555	9.1	10000	690	163	2.67
10000	690	270	4.4	20000	1379	144	2.36
8000	552	488	8.0	12000	828	195	3.2
15000	1034	238	3.9	30000	2069	79.3	1.3



Guidelines for Continuous Duty Applications for Maximizing Seal Life Performance

Pump Series	Maximum Cycles per Minute
0.3 hp	325 cpm
0.75 hp	225 cpm
1.5, 2.0 and 2.2 hp (Single and Double Drive Piston)	90 cpm
2.0 hp (Triple Drive Piston)	60 cpm
3.0 hp	90 cpm
6.0 hp	60 cpm
8.0 hp	90 cpm
10.0 hp	40 cpm

.33 hp (.25 kW) M Series Pump Models



Key Features

- Choice of 5 models, 9 ratios, 27 possible combinations
- Flows to 2 gpm (7.5 l/min)
- Choice of wetted materials
- Single air head
- Drive pressure 25 to 125 psi (1.8 to 9 bar)
- Pressures to 25000 psi (1724 bar)
- All Hydraulic fluids, water (plain or DI), solvents, mild chemicals, liquefied gases

Optional Modifications

Number	Description
-HP	Hand pump attachment (with handle). Provides manual operation of pump for precision pressure control or use without air power.
26082	Handle only.
26220-2	With handle.
26220-3	Without handle.
	Kits for converting existing units.
-V	Manual release with relief valve. For M and MS pumps only. Provides high pressure needle valve with internal adjustable safety relief downstream of pump outlet checks. Tank return is 1/2" NPT in pump body.
26063-3	Dead Man valve. 1/2" NPT port.
26064-3	Combination air regulator/filter with gauge. 1/2" NPT port.
26065-3	Speed control valve. 1/2" NPT port.
26065-3 plus 26064-3	-C air controls installed on pump. 1/2" NPT port.
26320	Mainifold mount inlet port. Provides O-ring boss in aluminum block to enable mounting inside of tank below oil level. Modification applies to M-21 through M-188 only.
28390	Palm or foot start/stop button drive. Spring loaded shut.
28700-1	Air OP release valve.
28926	Remote start/stop control. Provides 1/2" NPT bleed signal port for single line remote control.
29002	Viton air drive.
29697	Single stroke from remote air pulse. Useful for metering applications. One stroke per air pulse signal; eliminates automatic cycling. 1/2" NPT signal port.
51331	EPR seals for liquid section for 29723-10X ratio pumps.
51788	Piped exhaust—standard. Provides connection ports for drive and pilot exhausts. Enables under tank top mounting and/or natural gas drive.
51794	Piped exhaust—sour gas. With hand pump (HP).
51794-2	Piped exhaust—sour gas. Without hand pump (HP).
51804	Muffler (for use with piped exhaust modifications below). 1/2" NPT male port.

Model	Nominal Ratio	Maximum Working Pressure	Displacement per Cycle
M, MDSTV	-5	625 psi (43 bar)	.83 cu in (13.6 ml)
M, MS ^{PI}	-7 -12	900 psi (62 bar) 1500 psi (103 bar)	.6 cu in (9.8 ml) .26 cu in (5.3 ml)
M, MS ^{PI} 29723 ^{PI} **	-21 -36 -71 -110 -188	2600 psi (179 bar) 4500 psi (310 bar) 8800 psi (607 bar) 13900 psi (931 bar) 19000 psi (1034 bar)	2 cu in (3.3 ml) .12 cu in (2.0 ml) .06 cu in (1.0 ml) .039 cu in (0.6 ml) .023 cu in (0.4 ml)
MS	-220	29000 psi (1723 bar)	.021 cu in (3.4 ml)

** Not available in 188:1 ratio

(3) Maximum intermittent pressure for stainless steel in the MS and 29723 is 10000 psig (690 bar).

For service codes, see page 17.

For weights and dimensions, see page 18.

Number	Description
51809	Normally open air operated release with relief valve. Provides highest release flow capacity. Will hold full pump psi piloted from drive air. Vents are not threaded. Ref. drawing 56643 for tank top mounting parts.
51809-1	Normally closed air operated release with relief valve. Used to hold hydraulic jacks. Will release up to 11000 psi (using 100 psi air). Vents are not threaded. Ref. drawing 56643 for tank top mounting parts. Not available in 188:1 ratio.
51810	Safety relief valve. Relief is upstream of outlet check. Vent hole 1/16" NPT M or MS series -21 through 188.
51811	External air pilot. Provides 1/2" NPT port for external air to pilot for remote start/stop.
52340	Solid air cap.
52360	Electric stroke counter provision. Micro switch (BZE6-2RQ) mounted on upper cap trips with each cycle.
53175	Level II cleaning.
53304	High pressure outlet port. Fits 1/2" O.D. high pressure threaded and coned tube.
53784	Piped exhaust (drive only). For field conversion of any .33 HP pump. Provides 1/2" NPT exhaust port.
53935	Low temperature drive. Enables operation down to 5°F. Some sacrifice of seal life at normal temperature. M or MS series.
54179	Stroke adjuster (includes 29697 above). Useful for metering applications. Knurled knob with vertical scale on pump cap.
57905	No return spring. Provides improved fill on suction stroke pumping liquefied gases by utilizing the inlet pressure. Only available on M and MS series.
59888	Cycle timer installed.
80103	Noise reduction kit fitted.
80348	SAE outlet for M-pumps, 1/2" SAE, 6500 psi (448 bar) max.
81499	EPR Seals for M and MS series for Liquid Section.
82367	SS trim for 1/2 hp drive
82500	ATEX Modification (Available on MS & 29723 but not M series).
85630	Conversion kit, new style exhaust muffler.
86337	Extended life air drive.

.75 hp (.56 kW) Pump Models



Key Features

- One model available in 9 ratios
- Output pressures to 15000 psi (1034 bar)
- Flows to 1.5 gpm (5.7 l/min)
- Choice of wetted materials
- Single air head
- Drive pressure 3 psi to 100 psi (.2 to 7 bar)

Model	Nominal Ratio	Maximum Working Pressure	Displacement per Cycle
4B	-14	1500 psi (103 bar)	9 cu in (14.8 ml)
	-21	2300 psi (159 bar)	6 cu in (9.8 ml)
	-25	2700 psi (186 bar)	5 cu in (8.2 ml)
	-30	3200 psi (221 bar)	4.3 cu in (7.1 ml)
	-37	3800 psi (262 bar)	3.5 cu in (5.7 ml)
	-55	6000 psi (414 bar)	2.2 cu in (3.6 ml)
	-75	7800 psi (538 bar)	1.7 cu in (2.8 ml)
	-100	10600 psi (731 bar)	1.3 cu in (2.1 ml)
	-150	15000 psi (1034 bar)	0.88 cu in (1.4 ml)

For service codes, see page 17.

For weights and dimensions, see page 19.

Optional Modifications

Number	Description
-C	Air drive controls.
56364	Extreme cycling service. Not recommended for long stall periods.
56394	External air pilot port. 1/4" NPT. Allows remote start/stop of pump.
57639	Low drive air pressure. Allows user to regulate drive air to as low as 3 psi (2 bar).
57960	Single acting drive. Used for pumping liquefied gases under pressure.
58475	1/4" NPT port on drive for recycle valve connection.
59354	Noise reduction kit fitted.

Number	Description
59988	Cycle timer installed.
80637	SAE outlet fitting for ratio 37 to 100, 1/4" SAE, 6500 psi (448 bar) max.
82104	Viton air drive.
82500	ATEX modification.
86337	Extended life air drive.



1.5 hp (1.12 kW) Pump Models



Key Features

- Choice of 11 models, 13 ratios, 48 possible combinations
- Output pressures to 50000 psi (3448 bar)
- Flows to 22 gpm (83.0 l/min)
- Choice of wetted materials
- Single air head
- Drive pressure 3 to 150 psi (.2 to 10 bar)

Model	Nominal Ratio	Maximum Working Pressure	Displacement per Cycle
DSTV ⁽¹⁾	-1.5	160 psi (11 bar)	319 cu in (513.0 ml)
ATV, DTW ⁽¹⁾	4	1200 psi (83 bar)	200 cu in (328.0 ml)
AW, ASF, DF, DSF, DSTV	-B10	1600 psi (110 bar)	4 cu in (66.4 ml)
	-B15	2400 psi (165 bar)	2.7 cu in (44.3 ml)
	-25	4000 psi (276 bar)	1.6 cu in (26.6 ml)
	-35	5700 psi (393 bar)	1.2 cu in (19 ml)
	-60	9800 psi (676 bar)	.7 cu in (11 ml)
AW, ASF, DF, DSF, DSTV	-100	16500 psi (1138 bar)	.4 cu in (6.7 ml)
	-150	20000 psi (1375 bar)	.28 cu in (4.5 ml)
HF, HSF, DSHF	-151	25000 psi (1724 bar)	.28 cu in (4.5 ml)
	-225	37000 psi (2551 bar)	.18 cu in (3.0 ml)
	-300	50000 psi (3448 bar)	.14 cu in (2.3 ml)
HF	-450	45000 psi (3103 bar)	.09 cu in (1.5 ml)

(1) These series are "lift" pumps and maximum outlet pressure is (air drive x pump ratio) + inlet pressure

For service codes, see page 17.
For weights and dimensions, see page 20.

Optional Modifications

Number	Description
-C	Air controls (filter, regulator, gauge, shut-off). ½" NPT.
-CP	Air controls with precision regulator. ½" NPT.
-C0	Air controls with recycle button. ½" NPT.
-CPO	Air controls with precision regulator and recycle button. ½" NPT.
-B	Bottom Inlet (designate "B" before ratio dash number, "BR" on -B10, -B15, -B22 and -B32) 1.5 hp and 2 hp pumps (not applicable to high output, chemical, 2.2 hp, or AWD series pumps).
-W	Additional upper foot bracket.
16821	Low air pressure control feature. For operating at air pressures as low as 3 to 4 psi (.2 to .3 bar). Includes 28881 modification.
16831	Low temperature modification. For special sealing in air drive for operating temperatures from as low as -20°F up to normal +120°F.
16834	Exhaust adapter. With back pressure balance piston.
17860	Electrical stroke counter provision. Includes BZE5-2RQ microswitch.
25721	Mechanical stroke counter, installed (6 digit).
27964	Interconnecting inlet-outlet tubing. ½" female for 4:1 ratio series pumps (ATV-4 or DTV-4).
28000	Threaded vent (or purge) ports on standard distance piece. Except 1.5:1 ratio.
28003	Test port. Provides access port in pump's body between inlet and outlet check valves for 1.5 hp and 2 hp pumps. -10 ratio or higher, single acting.
28881	Air pilot modification. ½" NPT. Allows remote start/stop of pump.
29376	Three-way cycling spool. For 1.5 hp and 2 hp single acting pumps, for use with CO ₂ .
29702	Single stroke modification.

Number	Description
29806	Double distance piece. For 1.5 hp and 2 hp pumps only, except 1.5:1 ratio.
51050	Extreme service cycling modification. Not recommended for long stall periods.
51056	Exhaust/pilot vent combination.
51331	EPR (Ethylene propylene) static seals in wetted section. Applies to distance piece pumps only.
51345	Sour gas drive provision to N.A.C.E. specifications. 1.5 hp to 2.2 hp distance piece pumps only, single air head and double air head.
52788	Viton seals air drive.
53825	Severe Arctic low temperature service. -25, -35, -60, -100, -150, -151, -225, -300, -450 ratios.
54885	Rotate pump body 90° from standard.
54935	SS trim for 5/3 air drive.
55005	Tube ports. ½" SAE inlet and outlet. For 1.5 hp to 2 hp pumps. 15 pump minimum.
55516	Polyurethane ("W") seal. For ForTV series pumps, except high output models.
55630	Stainless steel (AISI-316) distance piece. For 1.5 hp to 2 hp pumps.
58353	Noise reduction kit fitted. Not available on AFD, DFD, ASFD or DSFD.
82460	HNBR seals in air drive section.
82500	ATEC modification (not available on AHW or DSXHW pumps).
82988	¾" High pressure outlet converts medium ratio 10-122 outlet ½" port to high pressure port.
86337	Extended life air drive.

1.5 hp (1.12 kW) High Output Flow Pumps

Available in a choice of 3 models, these high output, low ratio pumps are capable of pressures to 1200 psi (82 bar) and flow rates of up to 22 gpm (83 l/min). These are "lift" pumps whereby the outlet pressure equals the air drive x the pump ratio plus the inlet pressure.

Model DSTV-1.5 has a maximum air drive of 150 psi (10 bar) and is capable of pressures up to 180 psi (11 bar). The model ATV and DTV-4 work on a maximum air drive of 150 psi (10 bar) and have a maximum pressure rating of 1200 psi (83 bar). A noise reduction modification is available for applications where noise level is an issue.

Distance Piece (Separation)

Pumps with prefix "D" in the model number have aluminum distance piece between the air drive and pump section (except DSTV-1.5). Vent holes can be threaded 1/2" NPT female at extra cost. Specify modification number 28000. Horizontal mounting is recommended for non-exchange of contaminants.

Mounting Brackets

All series mounting brackets have 7/16" holes (slots) for 3/8" bolts. Upper mounting brackets are not furnished as standard on single air head non-distance piece units.

Dimensional Data

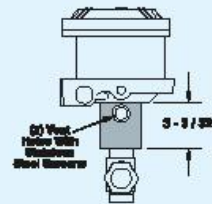

Mounting Brackets

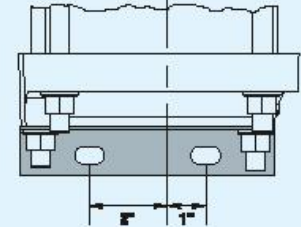

Optional Pump Inlets for Tank Mounting

To specify ratios -10, -15, -22 or -32, add "BR" between the model number and the ratio, e.g. AUV-BR10.

Inlet externally threaded 1 1/4" NPT male
Internally threaded 1" NPT female

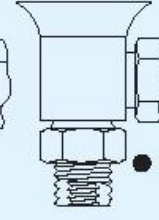
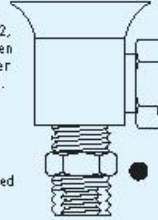

To specify ratios -25 through -303, add "B" between the model number and the ratio, e.g. AUV-B25.

Inlet on the bottom and externally threaded 1" NPT male
Internally threaded 1/2" NPT female

Drive inlet and exhaust are 1/2" NPT female. Drive inlet also includes a 1/2" NPT male x 1/2" NPT female (straight pipe thread) swivel adapter (connecting male nipple should include 30° inside bevel for proper fit).



2 & 2.2 hp (1.49 & 1.64 kW) Pump Models



Key Features

- Choice of 16 models, 13 ratios, 46 possible combinations
- Output pressures to 100000 psi (7000 bar)
- Flows to 5 gpm (15 l/min)
- Choice of wetted materials
- Double and triple air heads
- Drive pressure 3 to 100 psi (.2 to 7 bar)

Model	Nominal Ratio	Maximum Working Pressure	Displacement per Cycle
AW, ASF, DF, DSF, DSTV	-822	3200 psi (221 bar)	4 cu in (66.4 ml)
	-832	4800 psi (331 bar)	2.7 cu in (44.3 ml)
	-52	8000 psi (552 bar)	1.6 cu in (26.6 ml)
	-72	11000 psi (759 bar)	1.2 cu in (19 ml)
	-122	19000 psi (1310 bar)	.7 cu in (11 ml)
HF, HSF, DHF, DSHF	-202	33000 psi (2275 bar)	4 cu in (6.7 ml)
	-302	50000 psi (3448 bar)	28 cu in (4.5 ml)
DXHF, DSXHF	-452	70000 psi (4827 bar)	.18 cu in (3.0 ml)
	-602	75000 psi (5171 bar)	.14 cu in (2.3 ml)
DXHF, DSXHF	-683	70000 psi (4827 bar)	.18 cu in (3.0 ml)
	-903	75000 psi (5171 bar)	.14 cu in (2.3 ml)
DSXHW	-1373	100000 psi (6895 bar)	.09 cu in (1.4 ml)
AFD, DSFD, DFD, ASFD	-860	6500 psi (448 bar)	1.3 cu in (22 ml)

For service codes, see page 17.

For weights and dimensions, see page 20.

3 hp (2.24 kW) Pump Models



Key Features

- One model available in 8 ratios
- Output pressures to 33000 psi (2275 bar)
- Flow rates to 8 gpm (30 l/min)
- Single air head
- Drive pressure 3 to 150 psi (.2 to 10 bar)

Model	Nominal Ratio	Maximum Working Pressure*	Displacement per Cycle
ASFD	10	1600 psi (110 bar)	8.1 cu in (132.8 ml)
	15	2400 psi (165 bar)	5.4 cu in (88.6 ml)
	25	4000 psi (276 bar)	3.3 cu in (53.2 ml)
	35	5700 psi (393 bar)	2.3 cu in (38 ml)
	60	9800 psi (676 bar)	1.3 cu in (22 ml)
	100	16500 psi (1138 bar)	8 cu in (13.4 ml)
	150	20000 psi (1379 bar)	6 cu in (9 ml)
	202	33000 psi (2275 bar)	8 cu in (13.4 ml)

* Continuous/Intermittent

For service codes, see page 17.

For weights and dimensions, see page 21.

Optional Modifications (for 2 hp, 2.2 hp and 3 hp pump models)

Number	Description
-C	Air controls (filter, regulator, gauge, shut-off). 1/2" NPT.
-CP	Air controls with precision regulator. 1/2" NPT.
-C0	Air controls with recycle button. 1/2" NPT.
-CPO	Air controls with precision regulator and recycle button. 1/2" NPT.
-B	Bottom Inlet (designate "B" before ratio dash number, "BR" on -B10, -B15, -B22 and -B32) 1.5 hp and 2 hp pumps (not applicable to high output, chemical (2.2 hp, or AWD series pumps)
16821	Low air pressure control feature. For operating at air pressures as low as 3 to 4 psi (.2 to .3 bar).
16831	Low temperature modification. For special sealing in air drive for operating temperatures from as low as -20°F up to normal +120°F.
16834	Exhaust adapter. With back pressure balance piston.
17860	Electrical stroke counter provision. Includes BZES-2RQ microswitch.
25721	Mechanical stroke counter. Installed (6 digit).
27964	Interconnecting inlet-outlet tubing. 1/2" female for 4:1 ratio series pumps (ATV-4 or DTV-4).
28000	Threaded vent (or purge) ports on standard distance piece. Except 1.5:1 ratio and 3 hp pump.
28003	Test port. Provides access port in pump's body between inlet and outlet check valves for 1.5 hp and 2 hp pumps, -10 ratio or higher, single acting.
28881	Air pilot modification. 1/2" NPT - Allows remote start/stop of pump.
29376	Three-way cycling spool. For 1.5 hp and 2 hp single acting pumps.
29702	Single stroke modification. Except 3 hp pump.
29806	Double distance piece. For 1.5 hp and 2 hp pumps only, except 1.5:1 ratio.

Number	Description
51050	Extreme service cycling modification. Not recommended for long stall periods.
51056	Exhaust/pilot vent combiner.
51331	EPR (Ethylene propylene) static seals in wetted section. Applies to distance piece pumps only.
51345	Sour gas drive provision to N.A.C.E. specifications. 1.5 hp to 2.2 hp distance piece pumps only, single air head and double air head.
52788	Viton seals. Air drive only - 1.5 hp to 2.2 hp pumps only.
53325	Severe Arctic low temperature service. -25, -35, -60, -100, -150, -151, -225, -300, -450 ratios except 3 hp pump.
54885	Rotate pump body 90° from standard. Except 3 hp pump.
54935	SS trim for 5/3 air drive.
55191	Mounting ring kit for AWD series.
55192	3/4" NPT inlet port installed on AWD series (in place of threaded port).
55193	Extra foot bracket installed.
55305	Tube ports. 3/4" SAE inlet and outlet - for 1.5 hp to 2 hp pumps, 15 pump minimum.
55465	Ceramic Plunger-60 Ratio.
55516	Polyurethane "W" seal in "F" series pumps-except high output models.
55630	Stainless steel (SS-316) distance piece - for 1.5 thru 2 hp pumps.
58353	Noise reduction kit fitted. Not available on AFD, DFD, ASFD or DSFD.
58888	Cycle timer installed.
82460	HNBR Seals in air drive section.
82500	ATEK modification (not available on AAW or DSXHW pumps).
86337	Extended life air drive.

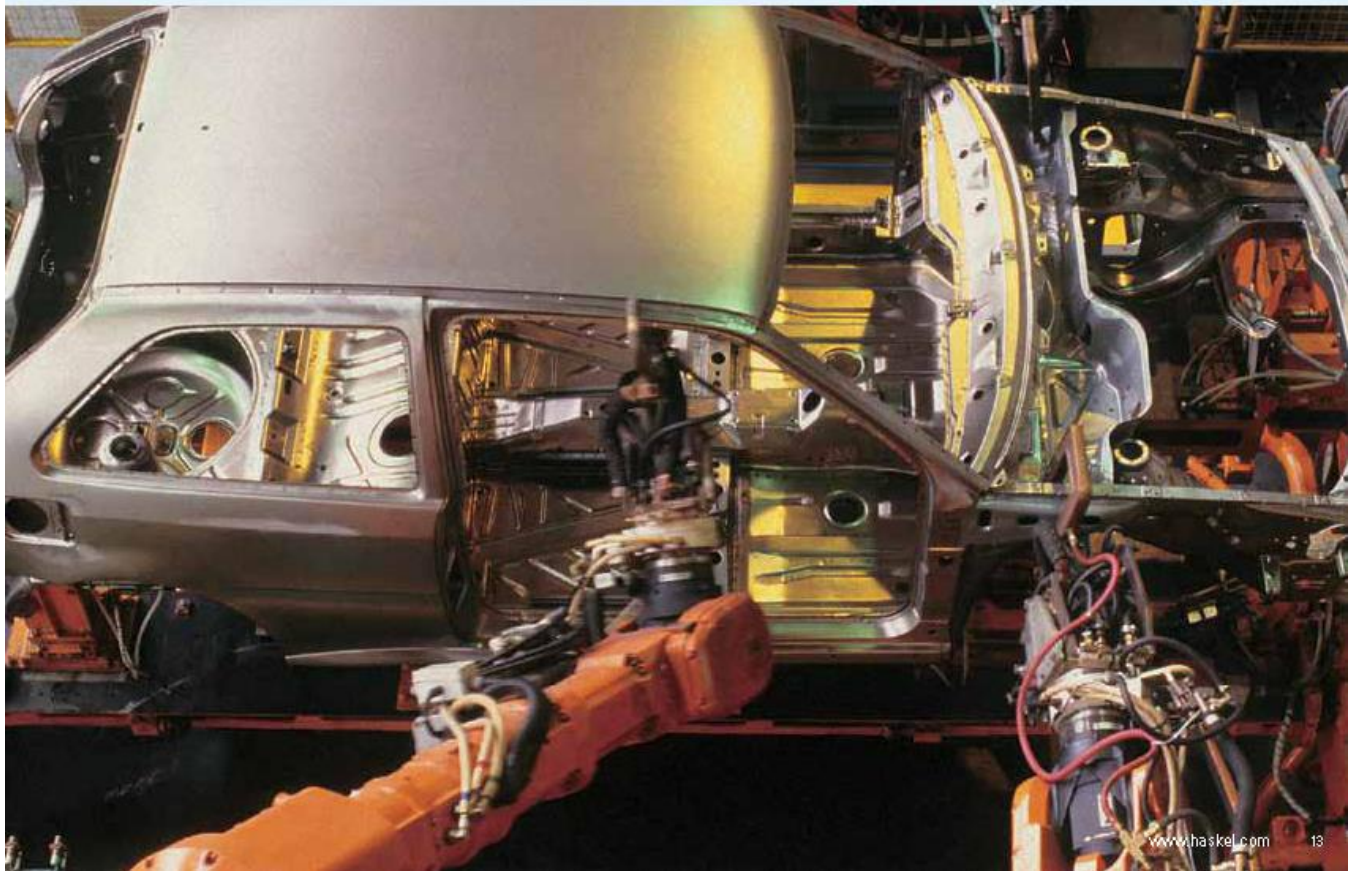

6 hp (4.47 kW) Pump Models



Key Features

- Choice of 10 models, 4 ratios, 20 possible combinations
- Output pressures to 10000 psi (690 bar)
- Flow rates to 21 gpm (80 l/min)
- Choice of wetted materials
- Single air head – double acting
- Drive pressure 3 to 125 psi (.2 to 9 bar)
- All hydraulic fluids, water (plain or DI), solvents

Model	Nominal Ratio	Maximum Working Pressure	Displacement per Cycle
GW, GSFD, DGFD ⁽¹⁾ , DGSFD ⁽¹⁾ , DGSTVD ⁽¹⁾	-12	4000 psi (276 bar)	159 cu in (260 m ³)
GW, GSFD, DGF, DGSD, DGSTV	-35	4375 psi (302 bar)	6.0 cu in (98 m ³)
	-60	7500 psi (517 bar)	3.5 cu in (57 m ³)
	-100	10000 psi (690 bar)	2.1 cu in (34.5 m ³)

(1) Double Acting "Lift" Pumps

For service codes, see page 17.

For weights and dimensions, see page 22.

Incorporating 10 models, this heavy duty range of double acting pumps provide pressures up to 10000 psi (690 bar) and flow rates up to 4 gpm (15 l/min).

Designed to operate with air drive pressures between 40 and 125 psi (2.8 and 9 bar). For drive pressures 3 to 40 psi (.2 to 2.8 bar), order 51875-1 mod.

8 hp (5.97 kW) Pump Models



Key Features

- Choice of 6 models, 5 ratios, 9 possible combinations
- Pressures to 22500 psi (1530 bar)
- Flow rates to 11.5 gpm (44 l/min)
- All hydraulic fluids, water (plain or DI), solvents, liquefied gases
- Choice of wetted materials
- Single air head – double acting
- Drive pressure 3 to 125 psi (.2 to 9 bar)

Model	Nominal Ratio	Maximum Working Pressure	Displacement per Cycle
8SFD, 8DFD, 8DSFD, 8DSTVD, 8FD	-25 ⁽¹⁾	4000 psi (276 bar)	14 cu in (229 m ³)
8SFD	-40	6000 psi (408 bar)	9 cu in (145.3 m ³)
8DSFD	-65	10000 psi (690 bar)	5.4 cu in (88.2 m ³)
	-100 ⁽¹⁾	10000 psi (690 bar)	3.5 cu in (57.5 m ³)
8HSFD	-225 ⁽¹⁾	22500 psi (1530 bar)	1.6 cu in (25.5 m ³)

(1) Double Acting "Lift" Pumps

For service codes, see page 17.

For weights and dimensions, see page 23.

10 hp (7.46 kW) Pump Models



Key Features

- Choice of 4 models, 4 ratios, 4 possible combinations
- Pressures to 36000 psi (2500 bar)
- Flow rates to 3 gpm (11 l/min)
- Drive pressure 3 to 125 psi (.2 to 9 bar)
- All hydraulic fluids, water (plain or DI), solvents, liquefied gases
- Choice of wetted materials

Model	Nominal Ratio	Maximum Working Pressure	Displacement per Cycle
D14 STD	125 ^{PSI}	16000 psi (1103 bar)	8.8 cu in (144.2 ml)
	315 ^{PSI}	36000 psi (2482 bar)	3.5 cu in (57.4 ml)
D14 SFD	125 ^{PSI}	16000 psi (1103 bar)	8.8 cu in (144.2 ml)
	315 ^{PSI}	36000 psi (2482 bar)	3.5 cu in (57.4 ml)

(1) Double Acting "Lift" Pumps

For service codes, see page 17.

For weights and dimensions, see page 23.

Incorporating two basic models, this heavy duty range of double acting pumps provide pressures up to 36000 psi (2482 bar) and output flow rate up to 3 gpm (11 l/min).

Operating from a maximum air drive pressure of 125 psi (9 bar), these pumps are designed for medium to high pressure service with minimum maintenance.

These large, slow speed pumps approach a seal life as high as 5 times that of many smaller pumps and this advantage becomes ever greater in heavy duty service involving water, or other liquids with negligible lubricity.

Optional Modifications (for 6 hp, 8 hp and 10 hp pump)

Number	Description
C	Air controls.
17860	Electrical stroke counter provision (includes BZE5-2RQ micro switch).
25721	Mechanical stroke counter installed (5 digit).
29077	Interconnecting tubing - 6 hp and 8 hp pumps, double ended.
29077-1	Interconnecting tubing - 6 hp and 8 hp pumps, double ended low ratio pumps.
29078	Same as 29077, 29077-1 double ended w/distance piece.
29078-1	Same as 29077, 29077-1 double ended w/distance piece low ratio pumps.
29079	Interconnecting tubing - 10 hp pumps.
29125	External pilot modification - for 6 hp thru 10 hp pumps.
51875-1	Low air pressure control - for 6 hp thru 10 hp pumps.
54030	Source gas air drive provision to NACE spec. 6 hp distance piece pumps only.

Number	Description
54312	Extreme service cycling modification - for 6 hp thru 10 hp pumps.
54306	Exhaust/pilot vent combiner.
55330	Interconnecting tubing 8D SFD-100 low pressure inlet.
55330-1	Interconnecting tubing 8D SFD-100 high pressure inlet.
55366	Interconnecting tubing 8D SFD-225.
57002	Witon seals - air drive only - 6 hp.
57944	Witon seals - air drive only - 8 hp.
59888	Cycle timer installed.
82800	ATEX modification available for 6 hp only, not available on 8 hp or 14 hp drive, nor on 6W, 6SE, D6 SE, 6 SFD, or D6 SFD models.
86337	Extended life air drive.



Power System Specialists

World safety standards and quality demands are rising. Component manufacturers are required to provide test certification and product quality assurance which can only be determined using the types of systems which Haskel can provide. Typically, we have built systems for production and field testing the proof, leak, and burst aspects of hoses, cylinders, and valves.

These systems can be portable, mobile, or static test rigs. We also offer a range of standard pressure packs used for power jacking, clamping, and other applications where reliable power is needed.

Selecting Your Accessories

Haskel can either provide accessories separately or supply them fitted to form a complete package suited to your application. Additionally, Haskel can fit customer nominated accessories. Our accessories catalog is available and our technical support team is always ready to advise you on the most suitable choice of accessories for your application.

- Air pilot switches
- Air pilot valves
- Regulating relief valves
- Directional control and release valves
- Hydraulic accumulators, gas receivers and storage cylinders
- High pressure valves, fittings and tubing
- Plenum chambers
- Port adapters
- Pressure regulators
- Gauge snubbers
- Filters
- Stainless steel check valves
- Intensifiers with integral checks for cycling
- Capillary type gauge snubbers

Quality and After-Sale Service



Haskel meets the requirements of international quality assurance ISO 9001. Build quality is matched by an innovative design and problem solving ability which stems from years of years of experience. Our representatives around the world are carefully chosen and trained to help you arrive at a correct product choice, and to offer a maintenance and parts service that is second to none.

Please ask for your copy of our latest accessories brochure.



Liquids Compatible with Haskel Pumps

To assist in easier pump selection, we have classified various popular liquids in groups and assigned to each group a service code. These service code numbers are featured in the chart to the right and are designated for each pump series. Seals and other wetted materials can be supplied to suit your preferred liquid. For advice, please contact our technical services personnel at 818-843-4000.

Services

Service Codes

- 1** Petroleum-based oils, kerosene, water with 5% soluble oil.
- 2** Plain water, diesel fuel.
- 3** Most phosphate ester-based fire-resistant hydraulic fluids, e.g. Pydraul, Lindol, Cellulube, Fyrquel, and Houghtosafe 1120 and petroleum-based solvents compatible with UHMWPE (Ultra-high Molecular Weight Polyethylene) dynamic seals and Viton static seals.
- 4** Petroleum-based solvents, e.g. boron fuels, aromatic hydrocarbons (benzene, toluene, xylene, hylene, etc.); chlorinated solvents (trichlorethylene, carbon tetrachloride, chlorobenzene, etc.); mercaptans, Dowtherm A, fluorinated solvents (fluorobenzene, fluorochlorethylene, etc.); Dowtherm E, plus all of Group 3 and some mildly corrosive acids compatible with wetted materials. See note 5A for service with methyl-ethyl-ketone, methyl acetone, diacetone, alcohol and freon 22.
- 5** Skydrol and Aerosafe hydraulic fluid; acetone and some alcohols (ethyl, methyl, and isopropyl).
- 5A.** Also suitable for these fluids if Viton static seals are replaced with EPR; specify modification number 51331 (no extra charge); e.g., 51331-MDTV-5. Most phosphate ester-based fluids solidify at approximately 30000 psi.
- 6** Deionized water; demineralized water.

Note: Dynamic seal life with non-lubricating fluids will understandably be less than with lubricating types.

Operating Temperatures

Drive Section

-4° (25°F) to +65°C (150°F) (low temperature seals are available for Arctic operation).

Liquid Section

For reasonable seal life, high temperature should be limited to 54° C (130° F), for F and W seal models, 135° C (275° F) for T and TV models (with distance piece).

hp	Model	Services						
		1	2	3	4	5	5A	6
.33	M	•						
	MS	•	•					
	MDTV	•		•			•	
	MDSTV	•	•	•	•		•	
	MCPV	•	•	•	•	•		
	29723	•	•	•		•		•
.75	4B -14 to -37	•						
	4B -55 to -150	•	•					
1.5 2 2.2	AW	•						
	ASF	•	•					
	DF	•		•			•	
	DSF	•	•	•			•	•
	HF	•						
	HSF	•	•					
	DHF	•					•	
	DSHF	•	•				•	•
	DSTV	•	•	•	•		•	
	ATV	•	•					
	DTV	•	•				•	
	DSTV -1.5	•	•	•	•		•	•
	AFD	•						
	DFD	•		•			•	
	ASFD	•	•					
DSFD	•	•	•			•	•	
DXHF	•					•		
DSXHF	•	•				•	•	
DSXHW	•	•						
3	ASFD	•	•					
6	GW	•						
	GSF	•	•					
	DGF	•		•			•	
	DGSF	•	•	•			•	•
	DGSTV	•	•	•	•		•	
	GWD	•						
	GSFD	•	•				•	
	DGFD	•		•				
	DGSFD	•	•	•	•		•	•
	DGSTVD	•	•	•	•		•	
8	8FD	•						
	8SFD	•	•	•	•		•	
	8DFD	•						
	8DSFD	•	•					
	8DSTVD	•		•			•	
	8HSFD	•	•	•	•		•	
10	D14STD -125	•	•	•	•		•	
	D14STD -315	•	•	•	•		•	
	D14SFD -125	•	•	•			•	•
	D14SFD -315	•	•	•			•	•

Weights and Dimensions

.33 hp (.25 kW) M Series Pump Models

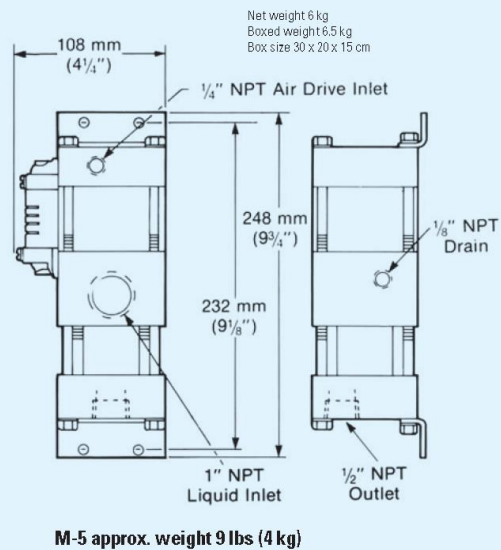
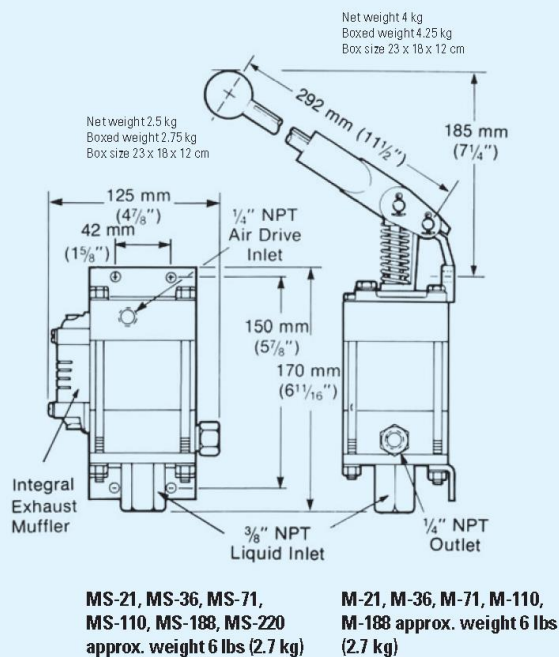
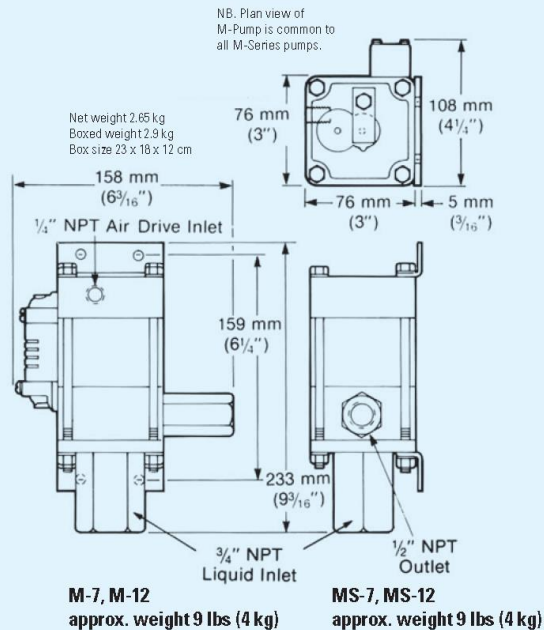

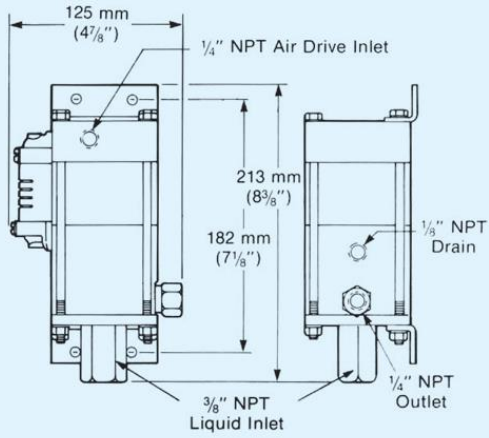

29723-21, 29723-36, 29723-71, 29723-110
 approx. weight 6.5 lbs (3 kg)

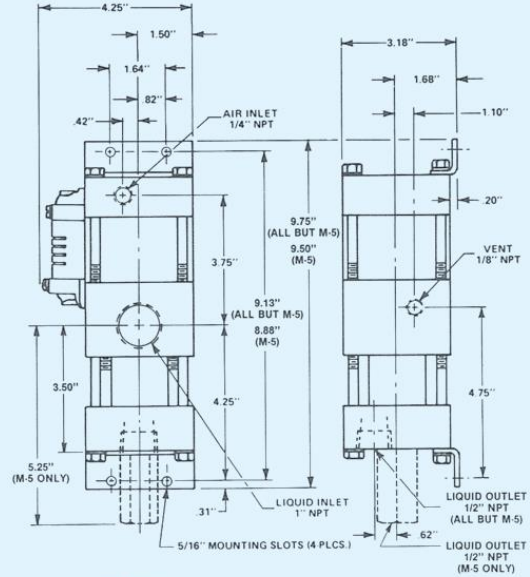

MDSTV-5
 Approx weight 15 1/2 lbs (7 kg)

.75 hp (.56 kW) Pump Models

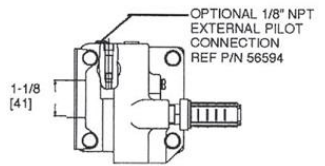
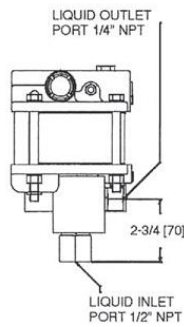
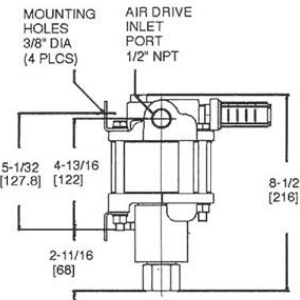
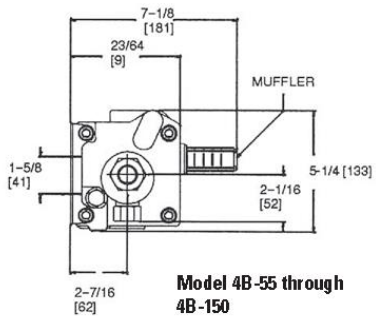
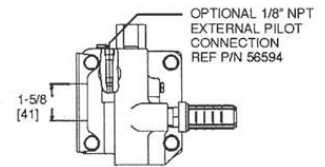
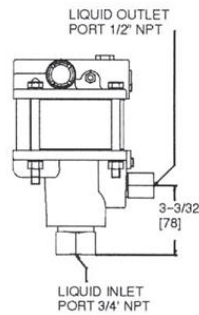
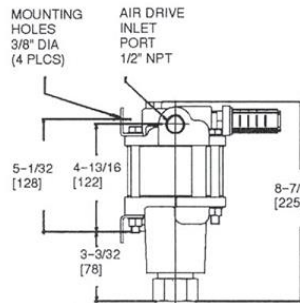
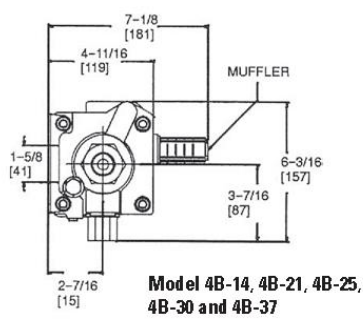

1.5 hp, 2 & 2.2 hp (1.12, 1.49 & 1.64 kW) Pump Models

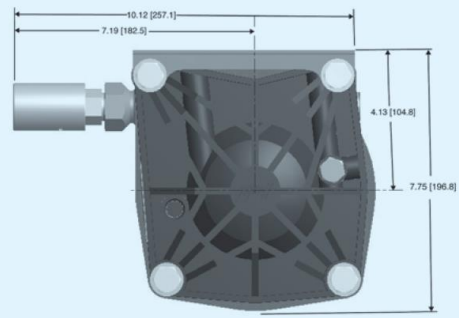
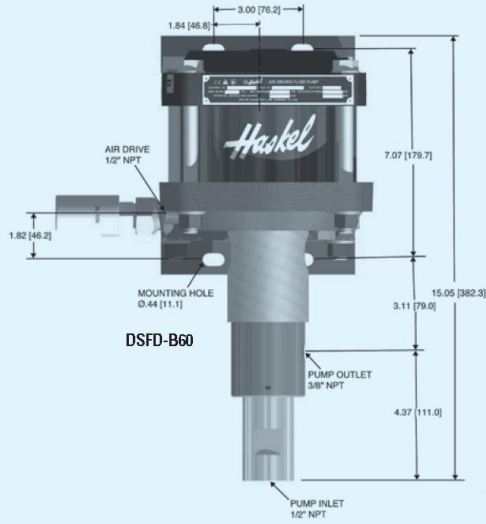

Net weight 18 kg
 Boxed weight 20 kg
 Box size 68 x 42 x 50 cm

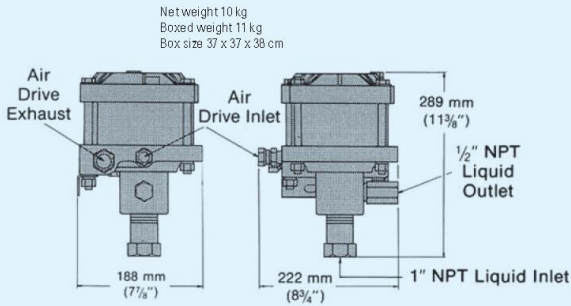

Net weight 10 kg
 Boxed weight 11 kg
 Box size 37 x 37 x 38 cm

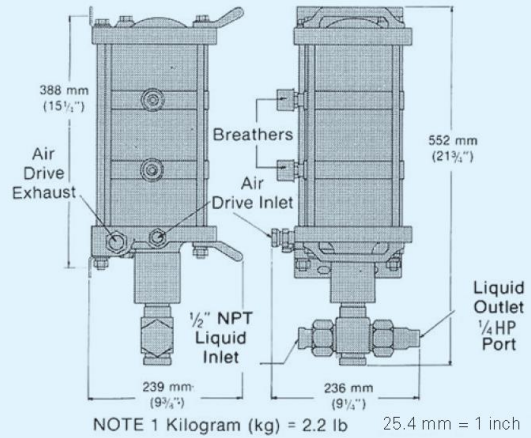

NOTE 1 Kilogram (kg) = 2.2 lb 25.4 mm = 1 inch

**1.5 and 2 hp low ratio pumps;
 -B10 and -B15 ratios**

**1.5 and 2 hp high ratio pumps;
 -683 and -903 ratios**

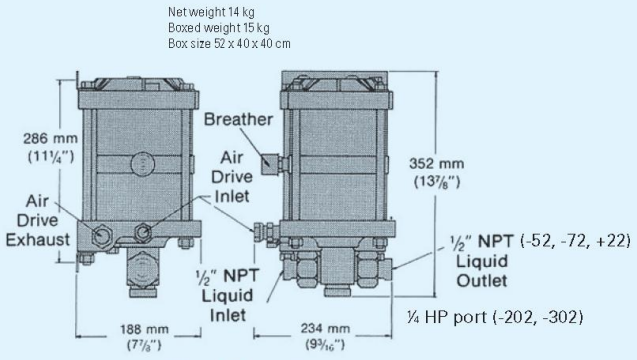

Net weight 14 kg
 Boxed weight 15 kg
 Box size 52 x 40 x 40 cm

**1.5 and 2 hp medium ratio pumps;
 -52, -72, -122, -202 and -302 ratios**

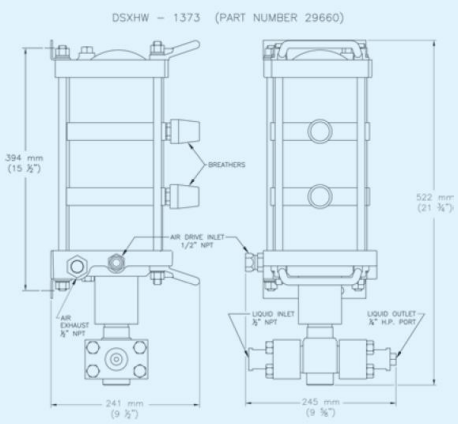

2 & 2.2 hp (1.49 & 1.64 kW) Pump Models

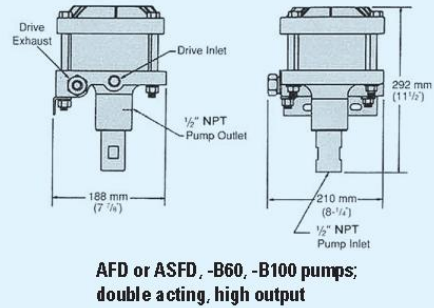
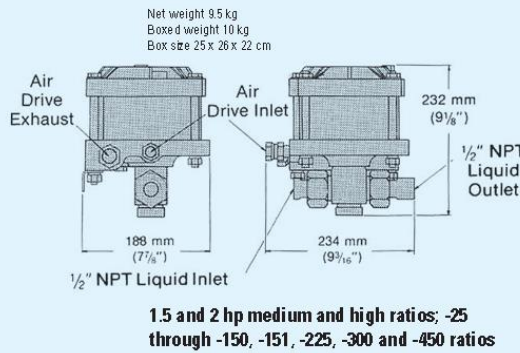
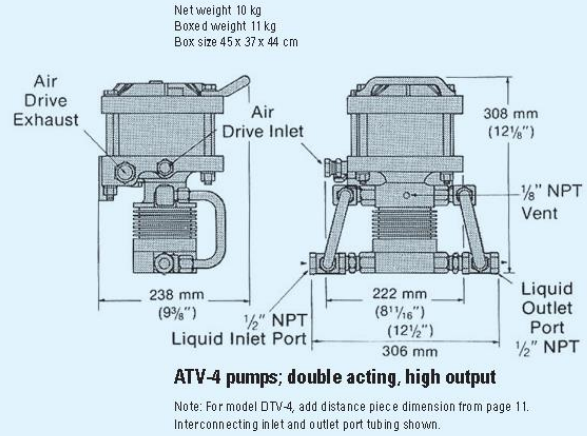
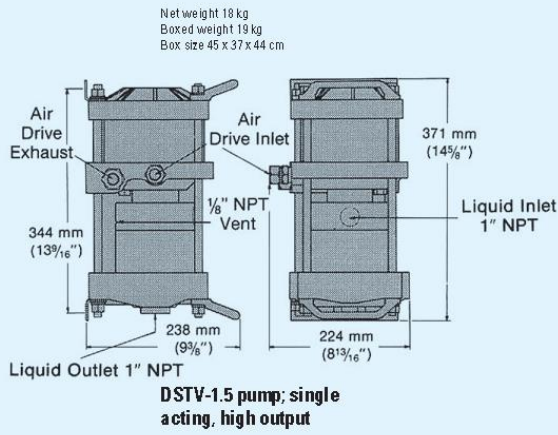

3 hp (2.24 kW) Pump Models

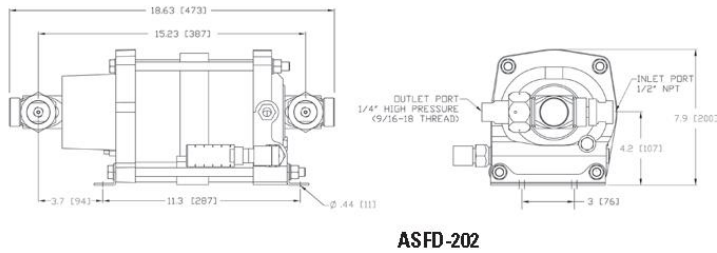
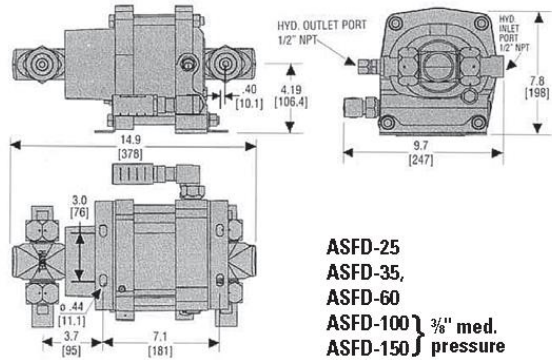
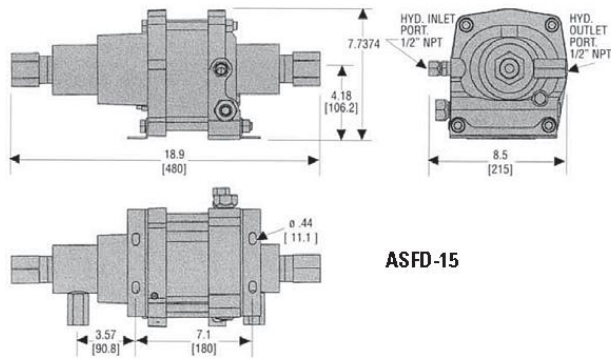

6 hp (4.47 kW) Pump Models

Net weight 31 lbs (14 kg)
 Boxed weight 35 lbs (16 kg)
 Box size 52 x 39 x 39 cm

All models have 2 off 1/4" NPT air exhaust ports and 1 off 3/4" NPT air drive inlet ports.

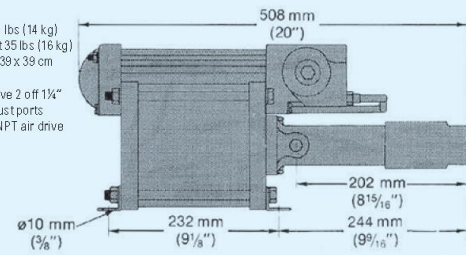

Models GW, GSF nominal ratio 35, 60 100:1

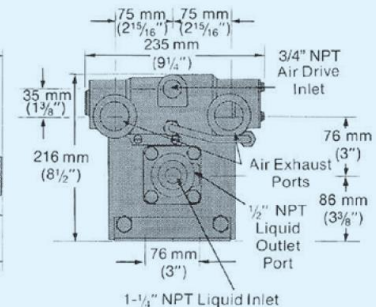

Net weight 41 lbs (18.5 kg)
 Boxed weight 48 (22 kg)
 Box size 66 x 41 x 49 cm

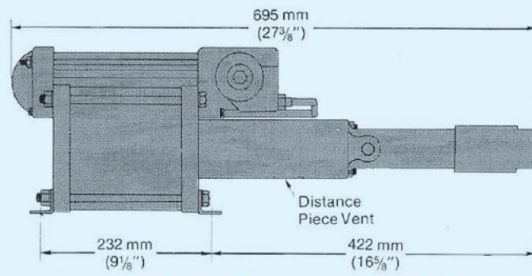

Models DGF, DGSF, DGSTV nominal ratio 35, 60 100:1

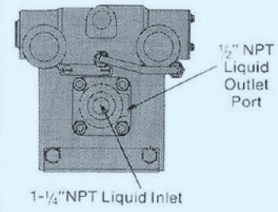

End dimensions as GW/GSF

Net weight 57 lbs (26 kg)
 Boxed weight 61 (27 kg)
 Box size 66 x 41 x 49 cm

If interconnecting piping for the two inlets and two outlets is required, specify modification 29077 with your order.

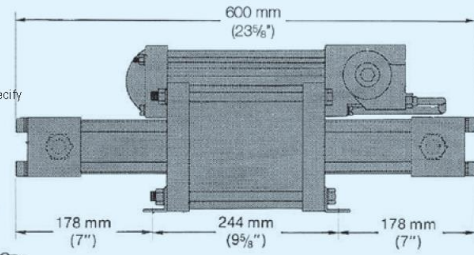
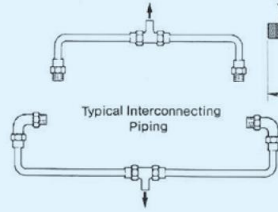

Models GWD, GSFD nominal ratio 12:1

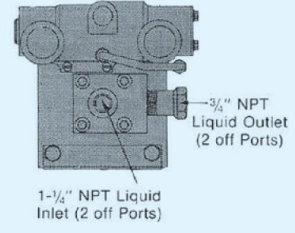

End dimensions as GW/GSF

Net weight 66 lbs (30 kg)
 Boxed weight 75 lbs (34 kg)
 Box size 91 x 51 x 39 cm

If interconnecting piping for the two inlets and two outlets is required, specify modification 29078 with your order.

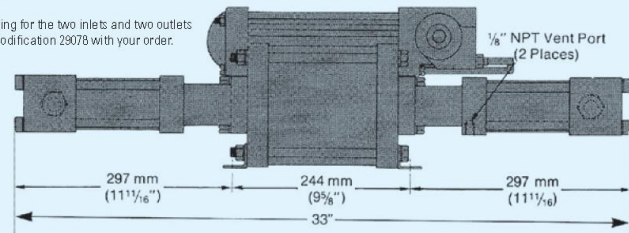

Models DGFD, DGSFD, DGSTVD nominal ratio 12:1

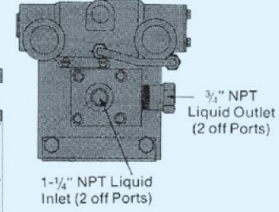

8 hp (5.97 kW) Pump Models

Model	Length	Width	Height	Weight	Air Drive	Liquid Inlet	Liquid Outlet
8FD-25 8SFD-25	25 3/4" (644.5 mm)	9 1/2" (241 mm)	11" (279 mm)	80 lbs (36 kg)	3/4"	1 1/4" NPT ⁽²⁾	3/4" NPT ⁽²⁾
8DFD-25 8DSFD-25 8DSTVD-25	34 3/4" (883 mm)	9 1/2" (241 mm)	11" (279 mm)	94 lbs (43 kg)	3/4"	1 1/4" NPT ⁽²⁾	3/4" NPT ⁽²⁾
8SFD-40	26 3/4" (683 mm)	9 1/2" (241 mm)	11" (279 mm)	64 lbs (29 kg)	3/4"	1" NPT	3/8" NPT
8SFD-65	26 3/4" (683 mm)	9 1/2" (241 mm)	11" (279 mm)	63 lbs (28.5 kg)	3/4"	1" NPT	1/2" NPT
8HSFD-225	28 3/4" (721)	9 1/2" (241 mm)	11" (279 mm)	71 lbs (32 kg)	3/4"	3/8" M/P (20K coned and threaded connection)	3/8" M/P (20K coned and threaded connection)
8DSFD-100	41 3/4" (1060 mm)	9 1/2" (241 mm)	11" (279 mm)	92 lbs (42 kg)	3/4"	1 1/4" NPT ⁽²⁾	3/4" NPT ⁽²⁾

10 hp (7.46 kW) Pump Models

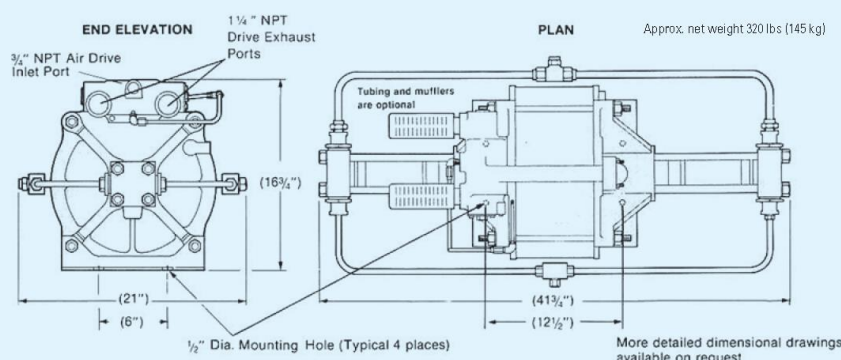

Note: See 29079 interconnecting tubing optional page 15. (29079 shown)
 Single Inlet port – 3/4 JIC male flare connection, single outlet port 3/4 HP ports (BuTech).
 Individual Pump ports – Liquid inlets 2 ea. 1/2 NPT ports, 2 ea. 3/4 HP ports (BuTech)

CELEBRATING OVER 80
YEARS OF HYDRAULIC AND
PNEUMATIC ENGINEERING
EXPERIENCE IN THE DESIGN
AND MANUFACTURING
OF HIGH PRESSURE
GENERATING EQUIPMENT
AND CONTROLS



Q16225
EMSS11920

Haskel International, Inc.

100 East Graham Place
Burbank, California 91502 USA
Tel: 818-843-4000 / Fax: 818-556-2549 or 818-841-4291
www.haskel.com

Haskel Europe Ltd.

North Hylton Road
Sunderland SR5 3JD, England, UK
Tel: 44-191-549-1212 / Fax: 44-191-549-0911
www.haskel-europe.com

Haskel Middle East

Hamilton Sundstrand Industrial ME FZE
P.O. Box 262384 Jebel Ali, Dubai, United Arab Emirates
Tel: +971 4886 2686 / Fax: +971 4886 2687
Email: sales@haskel.ae

Haskel Asia

Hamilton Sundstrand Singapore Industrial Pte. Ltd.
23 Tagore Lane #03-06
Tagore 23 Warehouse Complex, Singapore 787601
Tel: 65-6455-7589 / Fax: 65-6455-2841
www.haskel.com.sg

**For further information on Haskel
products, please visit us online at
www.haskel.com**

REVISIONS

1	USE OF THIS DRAWING IS LIMITED TO THE SPECIFIC CONTRACT AND PROJECT FOR WHICH IT WAS PREPARED. IT IS NOT TO BE REPRODUCED OR USED FOR ANY OTHER PROJECT WITHOUT THE WRITTEN PERMISSION OF THE ORIGINAL DRAWING ENGINEER.
2	ISSUE SHEET 1

INLET CHECK VALVE
M-50

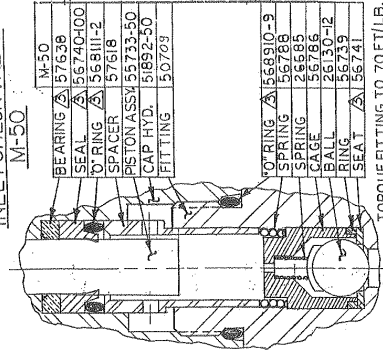

BEARING	M-50
SEAL	567639
O-RING	56740-100
SPACER	56711-2
PISTON ASSY	567518
CAP HYD.	56733-50
FITTING	567923
ROTOR RING	568910-9
SPRING	56788
CAGE	56785
BALL	56786
RING	56130-12
SEAT	56739
	56741

TORQUE FITTING TO 70 FT/LB.

<p>CONTRACT NO. _____</p> <p>DATE _____</p> <p>SCALE _____</p>	<p> 14B6801-0120 INLET CHECK VALVE MODEL "M" PUMP </p>
<p> DRAWN BY: _____ CHECKED BY: _____ DATE: _____ </p>	<p> PART NO. 14B6801-0120 REV. 1 SCALE: 1" = 1" </p>