

TRONAIR

OPERATION & SERVICE MANUAL

MODEL: 18-4208-X010

FOUR BOTTLE NITROGEN CART with BOOSTER AND MANIFOLD/ REGULATOR

January 1998

Revision: 04

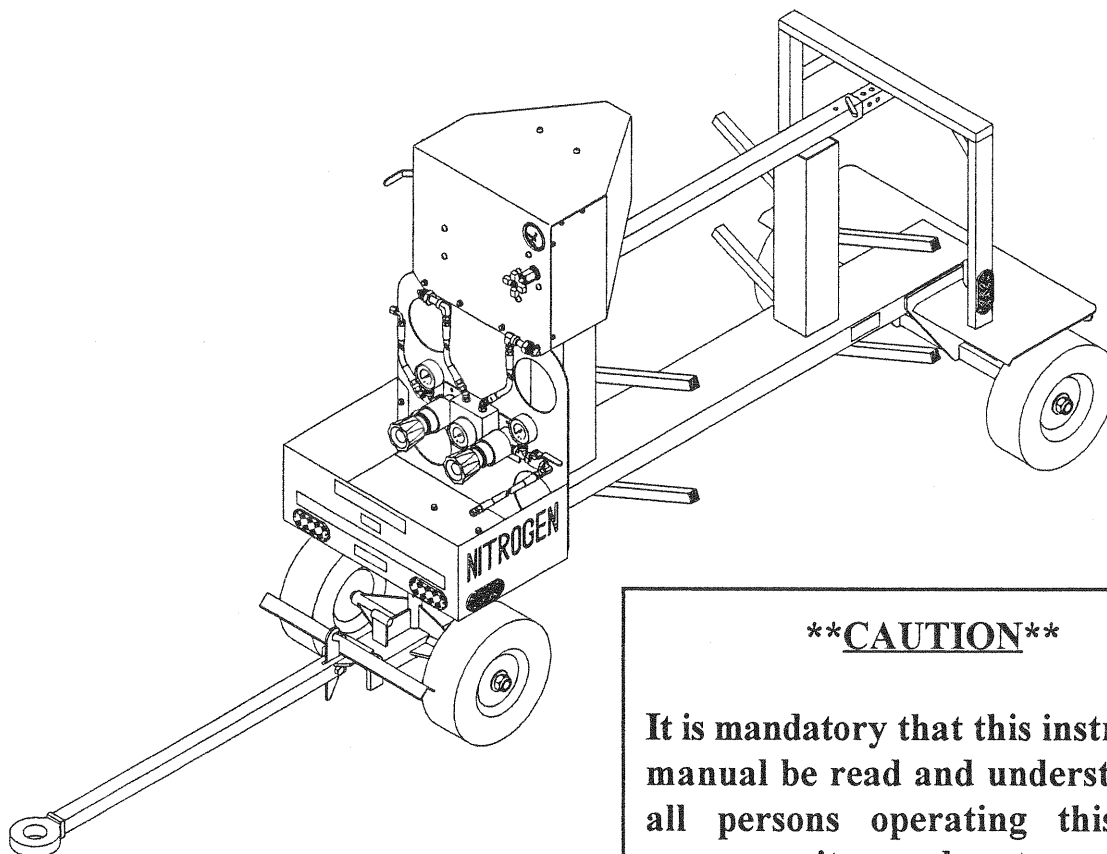

****CAUTION****

It is mandatory that this instruction manual be read and understood by all persons operating this high pressure nitrogen booster.

Tronair

South 1740 Eber Road
Holland, Ohio 43528-9794

Phone: (419) 866-6301 • 800-426-6301

Fax: (419) 867-0634

Web Site: www.tronair.com E-mail Address: mail@tronair.com

TRONAIR

18-4208-X010 Four Bottle Nitrogen Cart with Booster and Manifold/Regulator

TABLE OF CONTENTS

	<u>PAGE</u>
Figure 1 General Parts List	5
Figure 2 Operating Panel	6
Figure 3 Nitrogen Booster	7
Figure 4 Exploded View of Nitrogen Booster	7
Figure 5 Schematic & Component Listing	8
Figure 6 Efficient Bottle Usage	10
Figure 7 General Layout	15
Figure 8 Rupture Disc	17
Figure 9 Identification Tag Wire	17
1.0 General Description	1
2.0 Specifications/Features	2
3.0 Safety Instructions	3
4.0 Preparation for Use/Assembly Instructions	4
5.0 Operation of Nitrogen Booster	9
5.1 General Safety Requirements	9
5.2 Bottle Connection Instructions	10-11
5.3 Nitrogen System Connection	11-12
5.4 Charging the Aircraft Nitrogen System (High Pressure)	12
5.5 If Rupture Disc Ruptures	13
5.6 Disconnecting Nitrogen Booster from Aircraft	13
5.7 Charging the Aircraft Nitrogen System (Low Pressure)	14
6.0 Maintenance	16
6.1 Rupture Disc Replacement	17
6.2 Storage	17
7.0 Trouble Shooting	18
8.0 Parts List/Illustrations	19-26

TRONAIR

18-4208-X010

Four Bottle Nitrogen Cart with Booster and Manifold/Regulator

****CAUTION****

It is mandatory that this instruction manual be read and understood by all persons operating this high pressure nitrogen booster.

1.0 GENERAL DESCRIPTION

The Tronair Four Bottle Cart With Booster is designed to transport nitrogen bottles which are used in the aviation industry. The manifold contains two regulators. The high pressure regulator is for regulating booster output pressure from 0-4000 PSI, and the low pressure regulator is for operating nitrogen booster and servicing needs of 0-500 PSI.

The booster provides the capability of boosting remaining lower pressure nitrogen from supply bottles to the required higher aircraft system pressure; up to 4000 PSIG maximum.

****DANGER****

TO AVOID SERIOUS INJURY, LOSS OF LIMB OR DEATH:

1. **Do Not** use on **Low Pressure** aircraft components or systems such as tires, etc. This is a **Regulated Nitrogen Source** equal to supply pressure.
2. **Do Not** use with **Oxygen** or gas other than nitrogen.
3. **Do Not** exceed 4000 PSIG nitrogen pressure.

TRONAIR

18-4208-X010

Four Bottle Nitrogen Cart with Booster and Manifold/Regulator

2.0 SPECIFICATIONS / FEATURES

Model Number:	18-4208-0010 - Blue 18-4208-5010 - Yellow
Height:	52½" (134 cm)
Length:	82" (208 cm)
Width:	32¾" (83 cm)
Weight:	290 lbs. (131 kg)

CART:

- Easy loading
- Use with all standard 9" diameter nitrogen bottles; CGA 580 connection
- Adjustable bottle stop
- Bottles fully captured
- Pneumatic tires
- Parking brake
- Hose compartment

BOOSTER:

- Output hose: 25 feet long with #4, 37° JIC (female 37° flared swivel fitting) at aircraft hook-up end.
- Nitrogen output rating: 4000 PSIG maximum. **(Do not exceed)**
- Maximum supply bottle pressure: 3000 PSIG
- Minimum supply bottle pressure: 500 PSIG
- Nitrogen input to booster pump: 80 SCFM at 150 PSIG maximum
- System pressure relief is provided by a non resettable, 4300 PSI rupture disc assembly.

LOW PRESSURE REGULATOR:

- 0-500 PSI output
- 15 ft. service hose

TRONAIR

18-4208-X010 Four Bottle Nitrogen Cart with Booster and Manifold/Regulator

3.0 SAFETY INSTRUCTIONS

****CAUTION****

It is mandatory that this instruction manual be read and understood by all persons operating this high pressure nitrogen booster.

- 3.1 **General:** Information presented in this manual and on various labels, tags, and plates on the unit pertains to equipment design, installation, operation, maintenance and trouble shooting which should be read, understood, and followed for the safe and effective use of this equipment.
- 3.2 **Safety:** The operation, maintenance, and trouble shooting of this high pressure nitrogen booster requires practices and procedures which ensure personal operator safety and the safety of others. Therefore, this equipment is to be operated and maintained only by qualified persons in accordance with this manual and all applicable local codes.

NOTE:

Safety instructions specifically pertaining to this unit appear throughout this manual highlighted by the signal words ****WARNING****, ****CAUTION****, ****DANGER**** which identify different levels of hazard.

WARNING - Denote practices which if not carefully followed, could result in serious personal injury and / or death.

CAUTION - Denote practices which if not carefully followed, could result in minor personal injury or damage to this equipment.

Nitrogen equipment must be kept clean and free from contaminants at all times. It is imperative that all inspection, maintenance, testing and servicing of nitrogen system components be done by trained and qualified personnel using approved procedures.

System pressure relief is provided by a 4300 psi non-resettable rupture disc assembly. The rupture disc assembly is safely directed toward the ground. Care should be taken to keep the area below the nitrogen booster clear at all times in case of rupture disc rupture. The rupture disc itself is a non-fragmenting single use disc, and under normal operation, provides a long service life.

TRONAIR

18-4208-X010 Four Bottle Nitrogen Cart with Booster and Manifold/Regulator

4.0 PREPARATION FOR USE/ASSEMBLY INSTRUCTION

This unit is shipped without the booster mounted. Mount booster onto 4 bottle cart using instructions below. See Figure 1.

1. Install Item 10 (Bracket Weldment) to Item 5 (Piping Assembly) using Items 8, 9, and 11, see Figure 1.
2. Attach booster assembly to Item 1 (bottle cart) using Items 2, 3, and 4.
3. Secure booster to top rail of bottle cart using Items 7, 8, and 9.
4. Follow instructions in Figure 2 for proper hose connections, see Figures 2 and 5.
5. Install both the left side and right side panels (Items 6 and 12) using Item 13 (self tapping screws).

CAUTION

Only use bottles for which this unit was designed: 9 inch diameter, 3000 PSIG maximum pressure with CGA 580 connection.

Install bottles by removing bottle stop pin and sliding bottle stop rearward, place bottles in cart, slide bottles forward against front stop. If using only one or two bottles load the lower bottle compartment, this will prevent the cart from becoming too top heavy. Slide bottle stop securely against the back of the bottles and install bottle stop pin.

CAUTION

Maximum towing speed is 10 mph.

TRONAIR

18-4208-X010 Four Bottle Nitrogen Cart with Booster and Manifold/Regulator

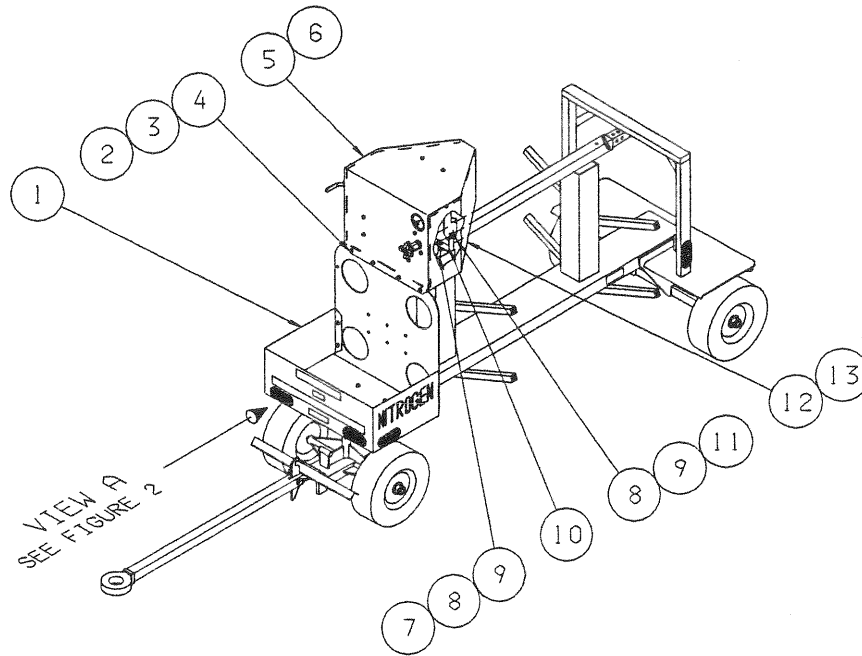

Figure 1

PARTS LIST

<u>ITEM</u>	<u>PART NUMBER</u>	<u>DESCRIPTION</u>	<u>QTY ON CART</u>
1	Z-2810	4 Bottle Cart Assembly	1
2	G-1100-105510	1/4"-28 Hex Head, Grade 5, 1" long Bolt	4
3	G-1250-1050N	1/4" Narrow Flatwasher	8
4	G-1202-1055	1/4"-28 Elastic Stopnut	4
5	Z-3385	Piping Assembly	1
6	S-1441-01	Left Side Panel	1
7	G-1370-01	3/8"-16 U-Bolt	1
8	G-1250-1070N	3/8" Narrow Flatwasher	4
9	G-1202-1070	3/8"-16 Elastic Stopnut	4
10	Z-2809-01	Bracket Weldment	1
11	G-1100-107004	3/8"-16 Hex Head, Grade 5 1/2" long Bolt	2
12	Z-2803-01	Right Side Panel	1
13	G-1178-103004	10-32 x 1/2" long Self Tapping Screw	15

Please specify model number and color when ordering replacement parts.

<u>MODEL</u>	<u>CART</u>	<u>BOOSTER</u>
18-4208-0010	Blue	Blue
18-4208-5010	Yellow	Yellow

TRONAIR

18-4208-X010

Four Bottle Nitrogen Cart with Booster and Manifold/Regulator

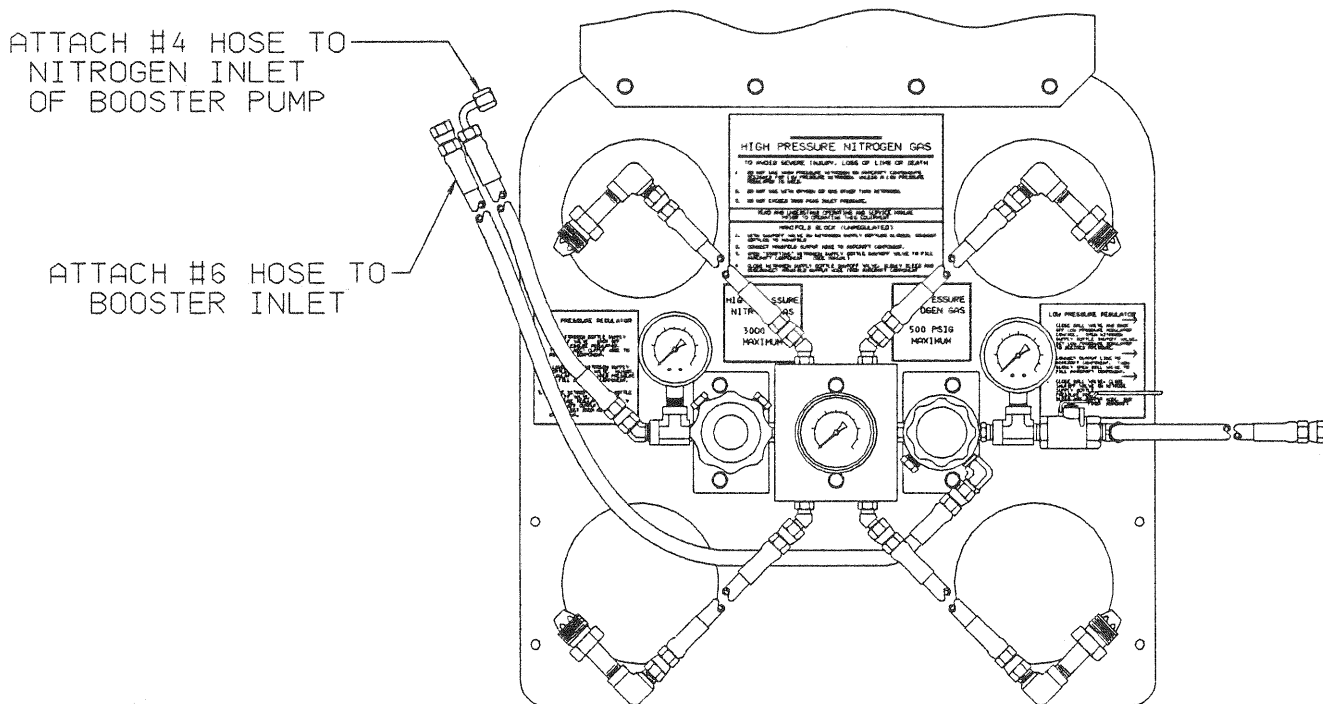

□ NOTES :

- 1 SEE FIGURE 5 (REAR VIEW OF BOOSTER PUMP) FOR HOSE CONNECTIONS.

Figure 2

Operating Panel

TRONAIR

18-4208-X010

Four Bottle Nitrogen Cart with Booster and Manifold/Regulator

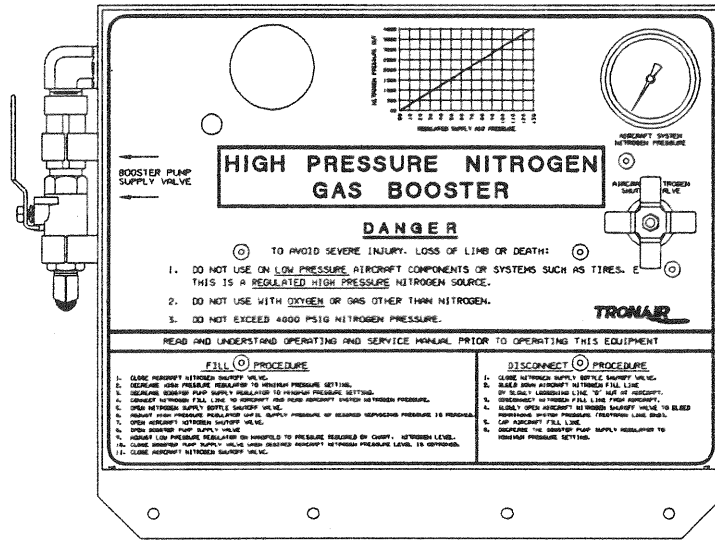

Figure 3

Nitrogen Booster

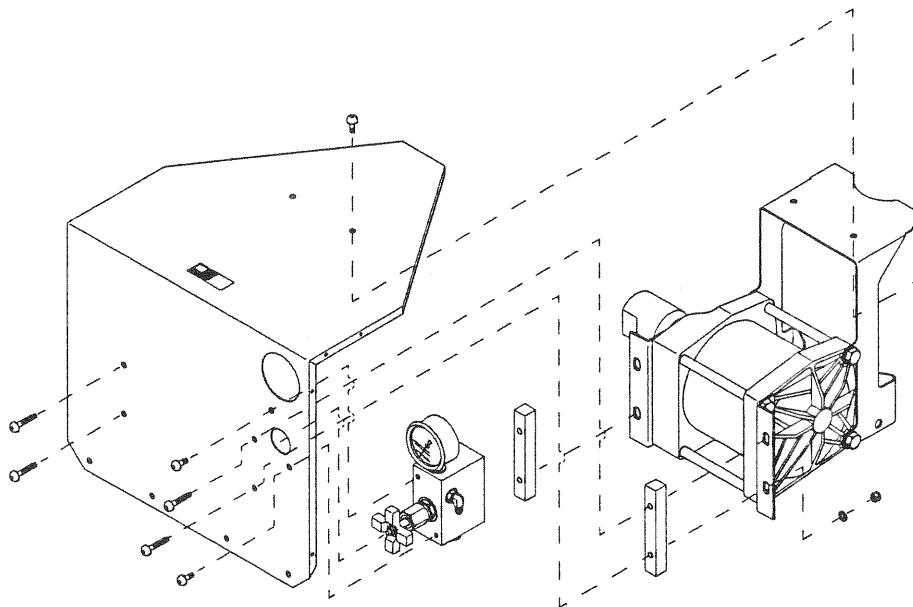
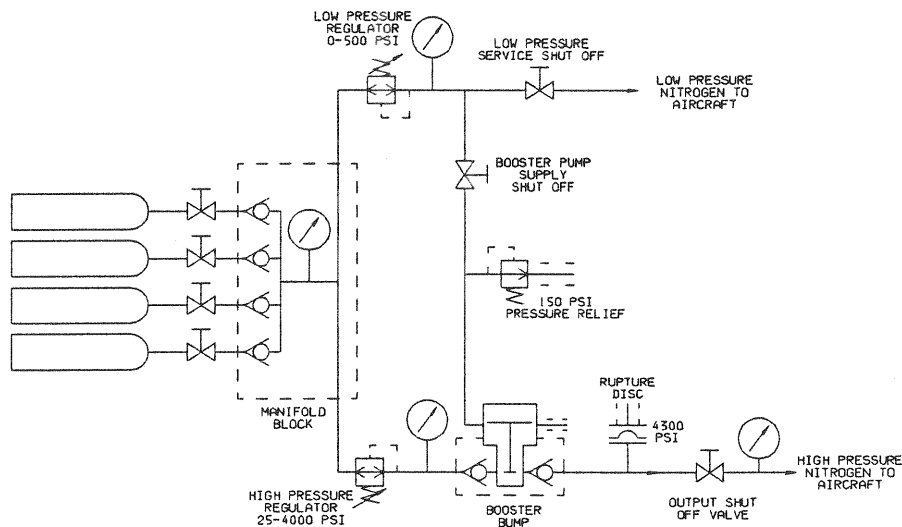

Figure 4

Exploded View of Nitrogen Booster

TRONAIR

18-4208-X010 Four Bottle Nitrogen Cart with Booster and Manifold/Regulator



Schematic

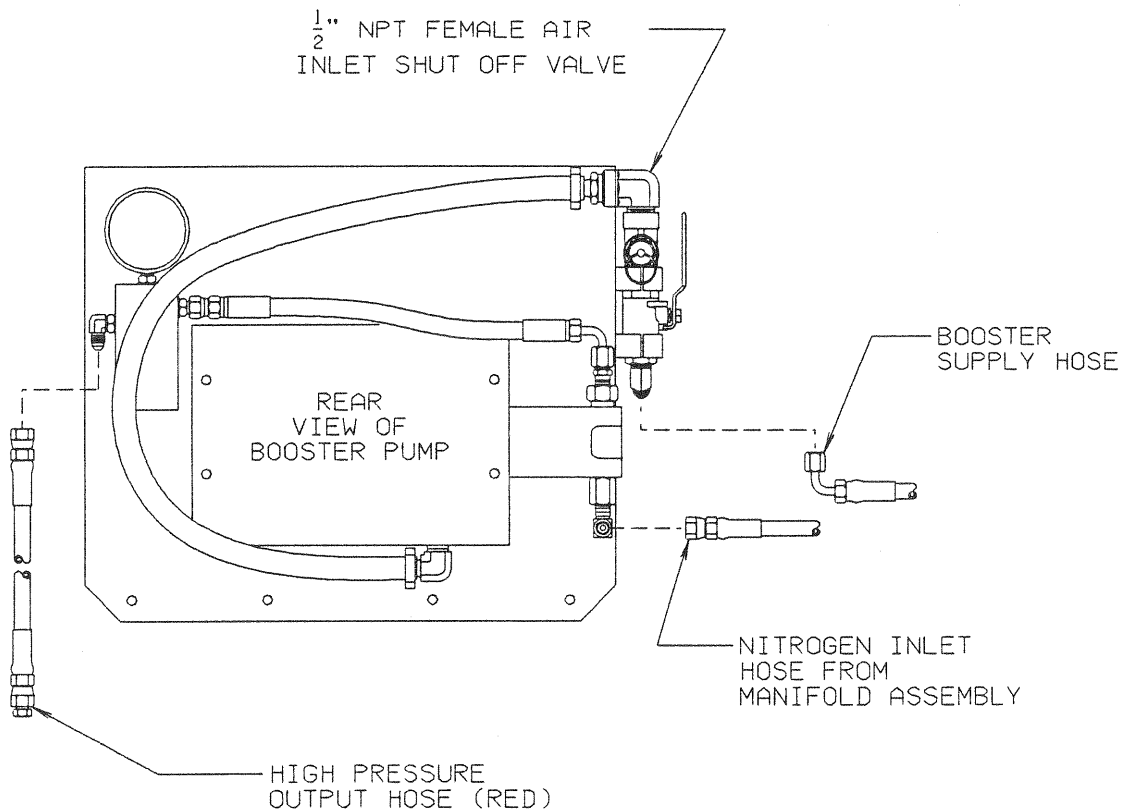

Figure 5
Schematic and Component Listing

TRONAIR

18-4208-X010

Four Bottle Nitrogen Cart with Booster and Manifold/Regulator

5.0 OPERATION OF NITROGEN BOOSTER

****WARNING****

TO AVOID SERIOUS INJURY, LOSS OF LIMB, OR DEATH

1. **Do not** use high pressure nitrogen on aircraft components designed for low pressure nitrogen.
2. **Do not** use with oxygen or gas other than nitrogen.
3. **Do not** exceed 3000 PSI inlet pressure.
4. Servicing and maintenance of nitrogen systems shall be done by only trained and qualified personnel using approved procedures.

GENERAL

Information presented in this manual, and on various labels on this unit, pertains to equipment specifications, installation, operation, maintenance, and trouble shooting which should be read, understood, and followed for the safe and effective use of this equipment.

TRAINING

Read this entire manual prior to operation of the unit. All personnel using this Nitrogen Booster should understand and follow this manual and receive training. We encourage our customers to call Tronair to discuss any operating or testing requirements. Phone: 1-800-426-6301.

5.1 GENERAL SAFETY REQUIREMENTS

PRESSURES

Gasses under pressure are a potential hazard in the form of stored energy. Accidents can occur when this energy is improperly handled. Be sure that all equipment used is compatible and designed to control the pressures encountered.

NITROGEN

Nitrogen is chemically stable, nonflammable, and does not support combustion.

HANDLING

Nitrogen handling must be done with care. The rapid expansion of nitrogen gas from a high pressure source to an area of low pressure, can produce cryogenic temperatures which could cause severe burns.

TRONAIR

18-4208-X010

Four Bottle Nitrogen Cart with Booster and Manifold/Regulator

EFFICIENT BOTTLE USAGE

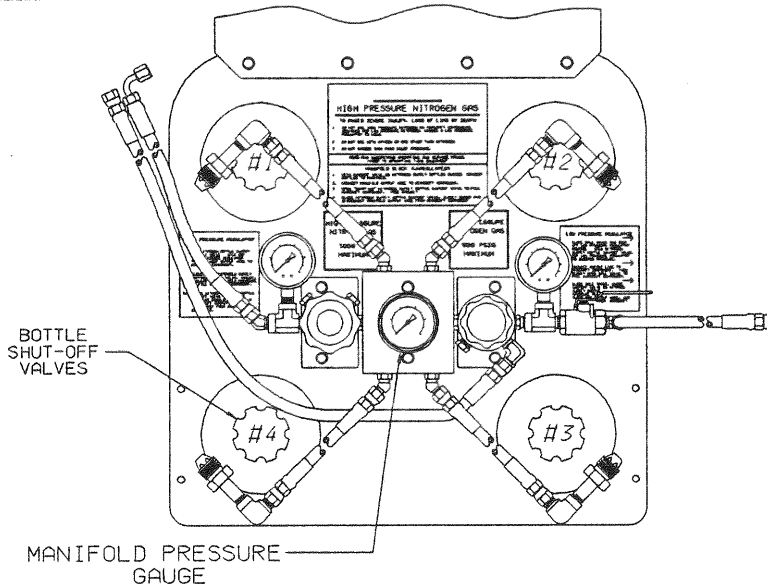

Figure 6

5.2 BOTTLE CONNECTION INSTRUCTIONS

1. Rotate the nitrogen supply bottles so that the manifold inlet hoses may be easily connected to the bottles. Make sure the hoses are not kinked or damaged.
2. Check that nitrogen supply bottle shut off valve is closed. Recheck all fittings for tightness.
3. Clean out nitrogen supply gas bottle valve outlet on one bottle and install nitrogen booster inlet brass fitting and hose. Stop and inspect any indication of cross-threading or galling. Repeat for the remaining three (3) bottles.
4. If less than four bottles are used, plug or cover unused inlet hoses to insure nitrogen system cleanliness.

5.2.1. TO READ INDIVIDUAL BOTTLE PRESSURE

1. Open a bottle shutoff valve.
2. Read pressure on manifold pressure gauge.
3. Close bottle shutoff valve.
4. **Slowly** loosen plug to relieve pressure.
5. Repeat procedure for other bottles.

TRONAIR

18-4208-X010

Four Bottle Nitrogen Cart with Booster and Manifold/Regulator

5.2 BOTTLE CONNECTION INSTRUCTIONS (Continued...)

5.2.2 EFFICIENT USE OF SYSTEM

Maximum nitrogen may be removed from supply bottles if aircraft are serviced from the lowest pressure bottle first. In this manner, the most nitrogen may be removed from each bottle. Even bottles with relatively low pressures may be used to service aircraft if the aircraft has a depleted system.

5.3 NITROGEN SYSTEM CONNECTION

5.3.1 Never operate this nitrogen booster if rupture disc is not in place.

****WARNING****

Do not attempt to circumvent the rupture disc assembly. If the rupture disc fails, it is imperative that an approved replacement rupture disc be installed and maintained for proper operation of this equipment. To ensure safety, only install approved rupture discs, breaking rings and O-rings in the pressure relief cavity. See illustrated parts list for replacement components.

****WARNING****

If there are any differences between the following instructions and the aircraft maintenance manual, the aircraft maintenance manual will take precedence.

5.3.2 Be sure all valves and controls are in the closed or “off” position.

5.3.3 Decrease all pressure regulators to the minimum pressure setting. The regulator adjustment knobs are the rotating type. Clockwise rotation of the knob increases pressure and counter-clockwise rotation reduces pressure.

****WARNING****

Be sure fill line is secured prior to purging the unit. This will prevent the hose end from “whipping” about if too much nitrogen is allowed to flow through the unit.

TRONAIR

18-4208-X010

Four Bottle Nitrogen Cart with Booster and Manifold/Regulator

5.3 NITROGEN SYSTEM CONNECTION (Continued...)

- 5.3.4 Connect nitrogen fill line loosely to aircraft and purge line by **SLOWLY** cracking open nitrogen supply bottle shutoff valve.
- 5.3.5 Tighten nitrogen fill line connection at aircraft.
- 5.3.6 Generally check unit and assure the tightness of all fittings, nuts and bolts.
- 5.3.7 The high pressure nitrogen booster is now ready to charge an aircraft nitrogen system.

5.4 CHARGING THE AIRCRAFT NITROGEN SYSTEM (HIGH PRESSURE)

- 5.4.1 If the nitrogen supply bottle pressure is lower than the aircraft nitrogen system pressure, check valves in the nitrogen booster will prevent back flow from the aircraft.
- 5.4.2 Connect the "RED" high pressure output hose from the booster to the aircraft.
- 5.4.3 **SLOWLY** open nitrogen supply bottle valve.
- 5.4.4 **SLOWLY** adjust low-pressure regulator valve of the manifold assembly to send nitrogen to the nitrogen booster.

****WARNING****

DO NOT USE ON LOW PRESSURE NITROGEN SYSTEM OR COMPONENTS.

- 5.4.5 Adjust the manifold low pressure regulator to prevent over-pressurization of the booster pump regulator. Clockwise rotation increases pressure, and counter-clockwise rotation reduces pressure.

Since the nitrogen booster pump compression ratio is 30:1, 135 PSIG of low pressure regulator inlet will develop approximately 4000 PSIG of output nitrogen pressure.
- 5.4.6 Adjust the booster regulator to obtain desired output nitrogen pressure required by the chart.
- 5.4.7 Close low pressure regulator valve when desired aircraft nitrogen pressure level is obtained.

****CAUTION****

Continued operation of this nitrogen booster at pressures above 4300 PSI may result in premature disc rupture.

TRONAIR

18-4208-X010

Four Bottle Nitrogen Cart with Booster and Manifold/Regulator

5.5 IF RUPTURE DISC RUPTURES

The pressure relief incorporated in this unit is provided by a rupture disc assembly. If the nitrogen system pressure exceeds 4300 PSI (\pm 05%), the disc will rupture. If rupture occurs, the following will result:

- The onboard aircraft nitrogen tank will bleed down until empty.
- The nitrogen supply bottle will bleed down until the supply valve is shut off.
- The nitrogen booster will remain inoperable until a replacement rupture disc is installed in the unit, since the rupture disc cannot be reset.
SEE 6.1 RUPTURE DISC REPLACEMENT.

5.6 DISCONNECTING NITROGEN BOOSTER FROM AIRCRAFT

- 5.6.1 SLOWLY close nitrogen supply bottle shut off valve. This will stop inlet nitrogen flow.
- 5.6.2 Decrease the shop air pressure regulator on nitrogen booster to minimum pressure setting. This will stop the booster pump from compressing existing nitrogen.
- 5.6.3 Decrease the manifold low pressure regulator to minimum pressure setting.
- 5.6.4 SLOWLY loosen, bleed down, and disconnect aircraft nitrogen fill line from aircraft.
- 5.6.5 Cap aircraft nitrogen fill line to prevent contamination.

TRONAIR

18-4208-X010

Four Bottle Nitrogen Cart with Booster and Manifold/Regulator

5.7 CHARGING THE AIRCRAFT NITROGEN SYSTEM (LOW PRESSURE)

- 5.7.1 Ensure that all valves and controls are in the closed or “OFF” position.
- 5.7.2 Ensure that all pressure regulators are decreased to minimum pressure settings.
- 5.7.3 Connect the “BLACK” low pressure output hose from the manifold assembly to the low pressure application.
- 5.7.4 **SLOWLY** open the nitrogen supply bottle valve.
- 5.7.5 Slowly increase the low pressure regulator on right side of manifold assembly to obtain desired low pressure output. (Clockwise rotation increases pressure).
- 5.7.6 Slowly close nitrogen supply bottle shut-off valve.
- 5.7.7 Decrease low pressure regulator to minimum pressure setting after completing low pressure charge. (Counter-clockwise rotation decreases pressure).
- 5.7.8 **SLOWLY** loosen, bleed down, and disconnect aircraft nitrogen fill line from aircraft.
- 5.7.9 Cap aircraft nitrogen fill line to prevent contamination.

TRONAIR

18-4208-X010 Four Bottle Nitrogen Cart with Booster and Manifold/Regulator

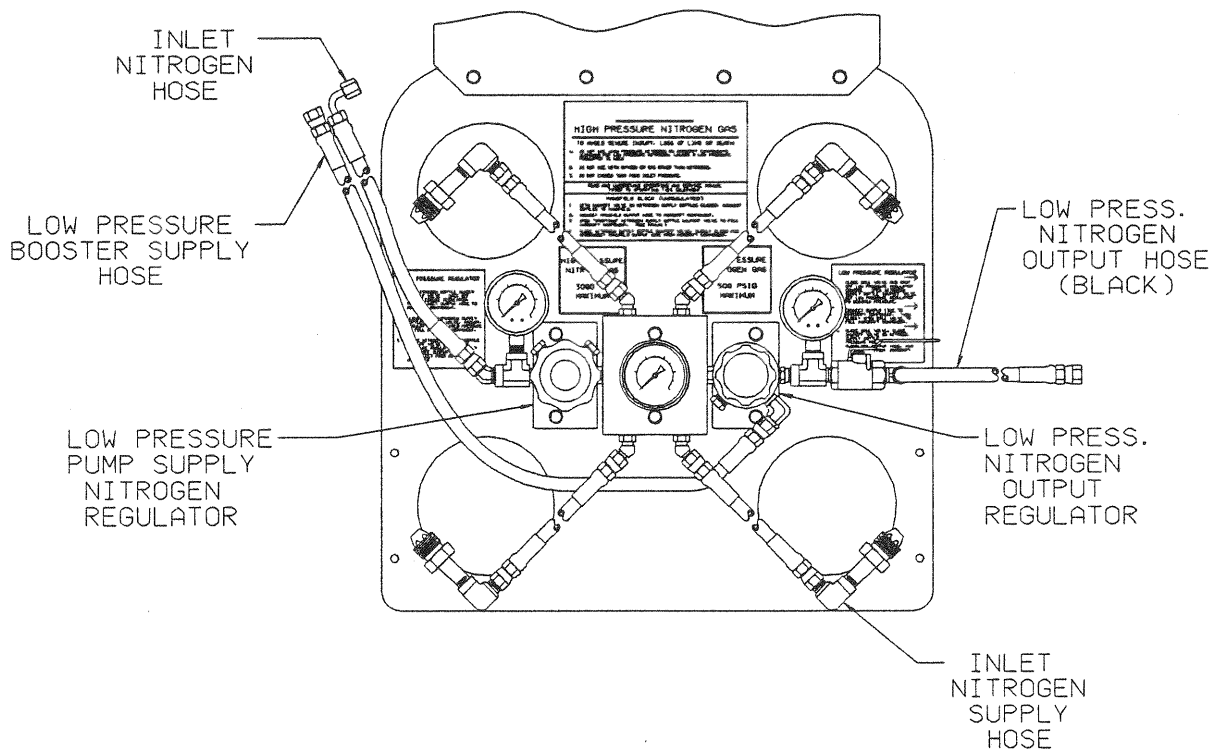

Figure 7

General Layout

TRONAIR

18-4208-X010

Four Bottle Nitrogen Cart with Booster and Manifold/Regulator

6.0 MAINTENANCE

- Maintain 45 - 50 PSI tire pressure.
- Grease wheel bearings quarterly.
- All maintenance performed on this high pressure nitrogen booster shall be conducted in accordance with all applicable codes governing the handling, operation, installation and trouble shooting for high pressure nitrogen operation. Maintenance is to only be done by qualified persons.
- See Appendix 2 for Air Driven Gas Booster Compressor Maintenance Instructions.
- Twice a year, or sooner if driven with Nitrogen or used heavily, the air cycling valve (Part Number 17567) in the Booster Pump, should be lubricated. The air cycling valve is separate from the nitrogen side of the pump and can be serviced without danger of nitrogen system contamination. Reference Appendix 2, Air Valve Maintenance Section and Air Cycling Valve seals kit part number 16771.
- The gauges on this unit should be inspected and calibrated annually to maintain and ensure accuracy.
- Manifold inlet hoses should be inspected weekly for signs of cracking or kinking, replace as necessary.
- Inspect nitrogen output hoses prior to each use for signs of cracking or kinking, replace as necessary.
- Generally keep the entire unit clean and free from any contaminants. Visually inspect for any system leaks or damage. Correction of any problems prior to unit operation is imperative for safe operation.

****WARNING****

Never apply high pressure gas to the high pressure section of this booster whenever the air driven section of this unit is disassembled, or when maintenance is being performed on unit.

TRONAIR

18-4208-X010 Four Bottle Nitrogen Cart with Booster and Manifold/Regulator

6.1 RUPTURE DISC REPLACEMENT

1. Close all valves, decrease air pressure regulator to minimum pressure setting, and **SLOWLY** disconnect unit from supply bottle and aircraft.
2. Locate replacement rupture disc and rupture disc identification tag.
3. Locate rupture disc port on bottom of cartridge block.
4. Remove old identification tag from plug fitting and discard wire and old rupture disc identification tag.
5. Remove plug, breaking ring, and failed rupture disc.
6. Inspect O-ring in port, replace if necessary (See Parts List.)
7. Place new rupture disc on O-ring in port with "bulge" facing the breaking ring (See Figure 8.)
8. Reinstall breaking ring over rupture disc and replace plug.
9. Tighten plug to 100 in-lb torque.
10. Wire identification tag included with new rupture disc to fitting (See Figure 9).
11. Unit is now ready to resume operation.

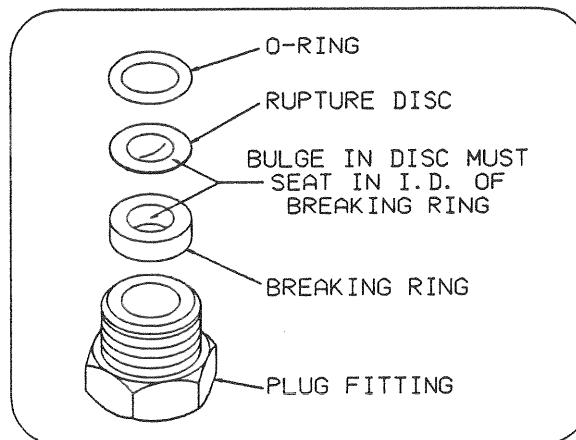

Figure 8 - Rupture Disc

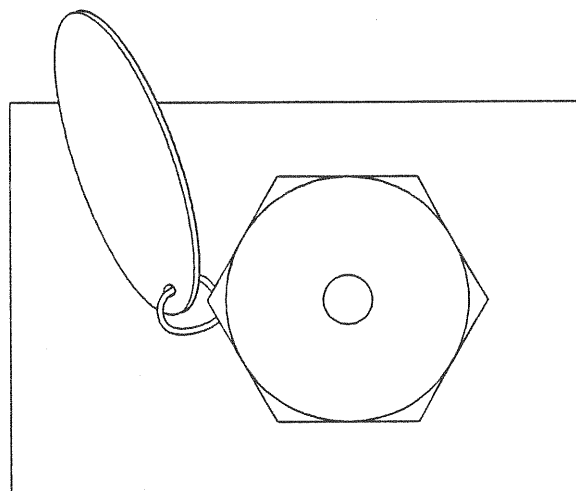

Figure 9 - Identification Tag Wire

6.2 STORAGE

Store the unit in a clean, dry area when not in use.

Be sure that all hoses are capped and the unit is covered for the duration of unit storage to ensure nitrogen system cleanliness for future aircraft system recharging.

TRONAIR

18-4208-X010

Four Bottle Nitrogen Cart with Booster and Manifold/Regulator

7.0 TROUBLE SHOOTING

TROUBLE	PROBABLE CAUSE	REMEDY
Will not run at low drive pressures (10-25 PSIG)	Excess friction of spool O-rings 568017	Re-lubrication or replacement of O-rings
Booster will not cycle, or slow cycling	Leakage of flow and/or pilot tubes	Replace O-rings on flow or pilot tubes
Unit will not build pressure	Indications that one or both pilot valves are malfunctioning	Remove pilot valves, inspect and/or replace
	Build-up of residue in muffler	Remove muffler and clean
	Nitrogen inlet pressure too low	Increase supply bottle inlet pressure to 350 PSIG minimum
“False” or double cycling, or continuous exhaust bleeding (air drive)	Small inlet supply line, restriction not allowing drive seals to function properly	Increase air drive piping to $1/2$ " I.D. and test system
Unit leaking oil	Worn seal	Replace O-rings in the following order: a: 56015 inside hex exhaust port b: 568017 spool O-rings c: 568020 sleeve O-ring
	Rod seal leakage	Replace rod seals and O-ring
Unit will not “dead head” or stall	Check valves contaminated	Remove, inspect, clean or replace as necessary
	Insufficient pressure at gas inlet	Increase supply bottle inlet pressure to 350 PSIG minimum
	High pressure piston leakage	Shut off air drive and remove muffler and cycling spool completely. Apply pressure to inlet port. If leakage is audible out of nitrogen vent port, replace gas piston seals.
Nitrogen will not flow through gas section with air drive “off”	Nitrogen filters plugged or contaminated.	Clean or replace filter elements.

TRONAIR

18-4208-X010

Four Bottle Nitrogen Cart with Booster and Manifold/Regulator

8.0 PARTS LIST

See Appendix 2 for Air Driven Gas Booster Compressor Replacement Parts.

Additional replacement parts available are as follows: