



OPERATION & SERVICE MANUAL

Model: 01-1374-0000
Custom Portable Towbar
Bell 429



10/2013 – Rev. 01

REVISION	DATE	TEXT AFFECTED
01	10/2013	Original Release

TABLE OF CONTENTS

	<u>PAGE</u>
1.0 PRODUCT INFORMATION	1
1.1 DESCRIPTION.....	1
1.2 MODEL & SERIAL NUMBER.....	1
1.3 MANUFACTURER.....	1
1.4 SPECIFICATIONS	1
1.5 FEATURES.....	1
2.0 SAFETY INFORMATION.....	2
2.1 GENERAL.....	2
3.0 TRAINING.....	2
3.1 TRAINING REQUIREMENTS	2
3.2 TRAINING PROGRAM	2
3.3 OPERATOR TRAINING.....	2
4.0 OPERATION.....	3
4.1 PRELIMINARY CHECKLIST.....	3
4.1.1 Towbar.....	3
4.1.2 Towing Head.....	3
4.2 USAGE PROCEDURE.....	3
4.2.1 Aircraft Attachment.....	3
4.2.2 Tug Attachment.....	3
4.2.3 Couplers.....	4
4.2.4 Towing Operation:.....	4
5.0 PROVISION OF SPARES.....	5
5.1 SOURCE OF SPARE PARTS.....	5
5.2 RECOMMENDED SPARE PARTS LISTS	5
6.0 IN-SERVICE SUPPORT.....	5
7.0 GUARANTEES/LIMITATION OF LIABILITY	5

Tronair towbars/heads must only be used with matching Tronair heads/towbars, and Tronair shear pins.

This product can not be modified without the written approval of Tronair, Inc. Any modifications done without written approval voids all warranties and releases Tronair, Inc., its suppliers, distributors, employees, or financial institutions from any liability from consequences that may occur. Only Tronair OEM replacement parts shall be used.

1.0 PRODUCT INFORMATION

1.1 DESCRIPTION

The Tronair Model -1374-0000 Custom Portable Towbar is a lightweight, carry-on towbar for Bell 429 Rotorcraft manufactured by Bell.

The portable towbar includes a telescoping towbar tube for collapsible storage. The aircraft attachment is by machined pins on the towing head to the nose landing gear axle. There is an eyebolt at the end of the towbar for towing.

1.2 MODEL & SERIAL NUMBER

Reference nameplate on unit

1.3 MANUFACTURER

TRONAIR, Inc.
1 Air Cargo Pkwy East
Swanton, Ohio 43558 USA

Telephone: (419) 866-6301 or 800-426-6301
Fax: (419) 867-0634
E-mail: sales@tronair.com
Website: www.tronair.com

1.4 SPECIFICATIONS

Aircraft Application	Bell 429 Rotorcraft
Maximum Aircraft Gross Weight..	7,000 lbs (3.18 Metric tons)
Length	133.187 in (28.3 cm) From eyebolt centerline to aircraft attachment centerline when fully extended
	57.37 in (69.5 cm) Overall collapsed (towbar only)
Width	14.07 in (35.7 cm)
Height.....	6.56 in (16.7 cm)
Material	Towbar Aluminum
Towing Head.....	Steel
Finish.....	Blue Powder Coat

1.5 FEATURES

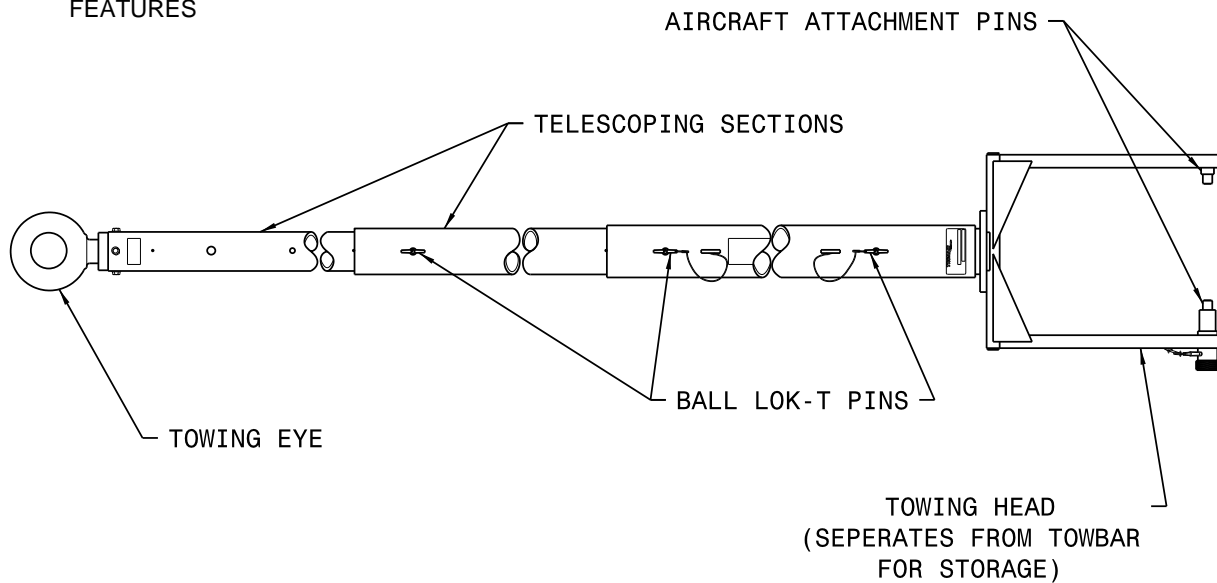

FIGURE 1 – Features

2.0 SAFETY INFORMATION

2.1 GENERAL

The Tronair Model 01-1374-0000 Portable Towbar is used for moving Bell 429 Rotorcraft only.

To ensure safe operation, please read the following statements and understand their meaning. This manual contains safety precautions which are explained as follows. Please read carefully.



WARNING! is used to indicate the presence of a hazard that can cause **severe personal injury, death, and/or substantial property damage** if the Warning Notice is ignored.

CAUTION! is used to indicate the presence of a hazard which will or can cause **minor personal injury or property damage** if the Caution Notice is ignored.



WARNING!

A damaged or bent towbar should not be used. Towbar should be repaired or replaced.

3.0 TRAINING

3.1 TRAINING REQUIREMENTS

The employer of the operator is responsible for providing a training program sufficient for the safe operation of the towbar.

3.2 TRAINING PROGRAM

The employer provided operator training program should cover safety procedures concerning use of the towbar in and around the aircraft at the servicing location.

3.3 OPERATOR TRAINING

The operator training should provide the required training for safe operation of the towbar.

NOTE: Maintenance and Trouble Shooting are to be performed by the skilled and trained technician.

4.0 OPERATION

4.1 PRELIMINARY CHECKLIST

4.1.1 Towbar

- Check lunette for bending, excessive wear and deformity.
- Check tube section ball lok-T pins. Ensure ball lok-T pins are securely attached to the lanyard tabs. Ensure ball lok-T pins are not missing.

4.1.2 Towing Head

Check welds between side rails and head rail for cracks:

- Check welds between side rails and stationary pin. Also sliding pin wear sleeve for cracks.
- Check sliding pin ball lok-T pin. Ensure ball lok-T pin is securely attached to the side rail via its lanyard. Ensure ball lok-T pin is not missing.
- Check sliding pin for bending or excessive wear. Ensure sliding pin slides freely.
- Check sliding pin roll pin. Ensure roll pin is not loose or missing.

4.2 USAGE PROCEDURE

4.2.1 Aircraft Attachment



CAUTION!

It is recommended that your towbar be attached to the aircraft first, and then connected to the tug to avoid possible aircraft damage.

- Ensure the sliding pin is locked in place using the ball lok-T pin.

4.2.2 Tug Attachment



CAUTION!

Damage to the towbar or aircraft can result from an excessive towbar angle during towing operations. Reference Figure 2.

- Use a pintle height so that the towbar is as level as possible during towing. Also, the pintle hook height should prevent contact of the towbar with the ground during towing.

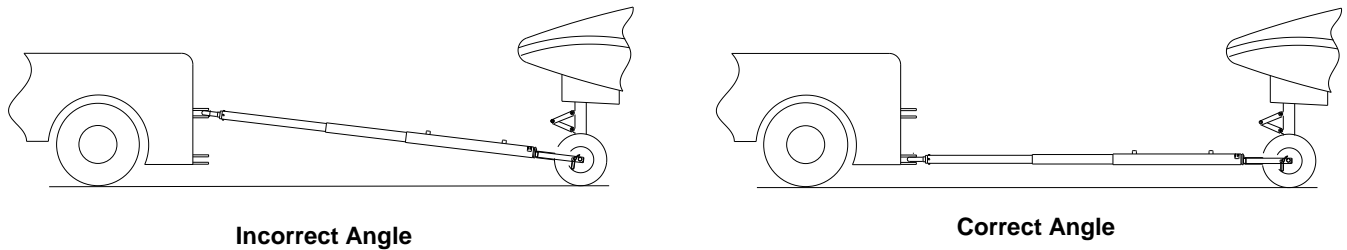

FIGURE 2

4.2.3 Couplers



CAUTION!

Damage to the towbar or aircraft can result while towing with the following types of couplers:

- Lift Head
- Standard Duty Latch
- Vertical Side Swing Latch
- Swivel Hook

The couplers listed above are known to cause binding and failure in the lunette eye. Indicators of binding are wear on outside diameter of the eyebolt and indentation on the inside diameter of the eyebolt.

Reference Figure 3.

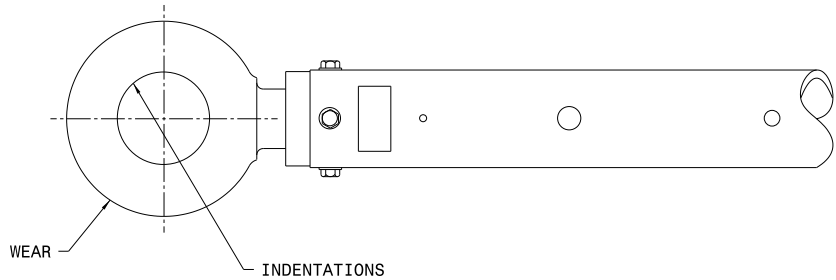

FIGURE 3

Tronair recommends a telecoupler pintle hook arrangement. This arrangement is known to eliminate binding. Tronair offers a Standard Telecoupler, Model Number 01-1950-5000, for use on tugs. **Reference Figure 4.**

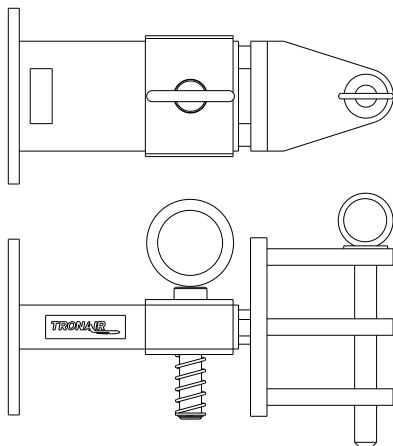

FIGURE 4
01-1950-5000 Standard Telecoupler

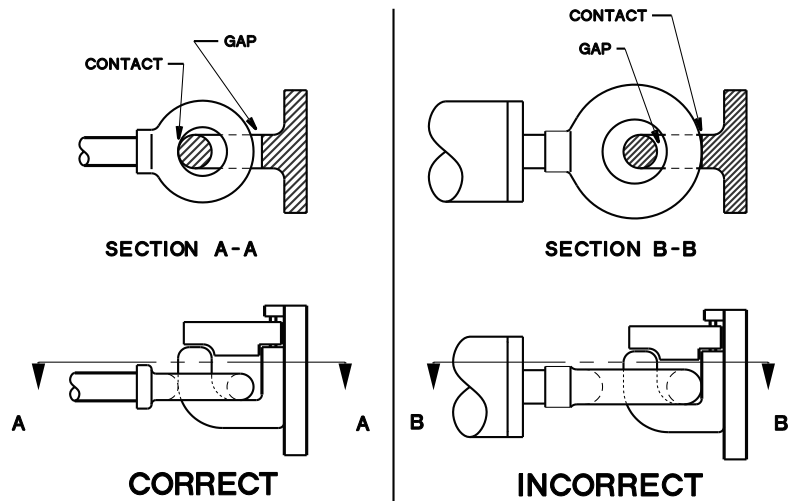

FIGURE 5

Damage to the towbar and/or aircraft can result by towing or pushing an aircraft with an incorrect size eyebolt or pintle pin. A correct size eyebolt will make contact with the pintle pin. A gap between the eyebolt outside diameter and the coupler face plate should be easily seen. An eyebolt which is too large will cause the eyebolt to make contact with the face plate of the coupler. When the eyebolt is too large for the coupler, a gap between the inside diameter of the eyebolt and the coupler face plate will be seen. **Reference Figure 5.**

To ensure proper towing and pushing, check to make sure the pintle pin diameter is not too long for the eyebolt's inside diameter. An approximate one-half inch (1/2") gap between the pin diameter and the eyebolt should be seen. If any of these conditions are not met, please contact Tronair for information to obtain a new coupler.

4.2.4 Towing Operation:

Damage to the towbar or aircraft can result from pushing an aircraft while maintaining too sharp of an angle between the tug and the aircraft. Contact between the towbar weldment and the tug must be avoided. It is recommended that the angle between the tug and towbar not exceed 90°. **Reference Figure 6.**

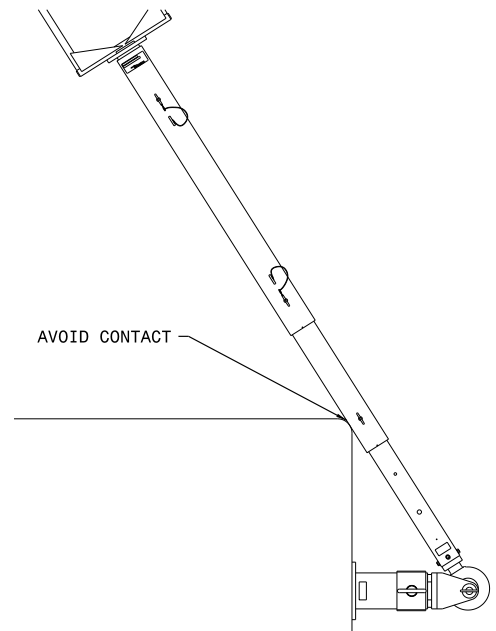

FIGURE 6



5.0 PROVISION OF SPARES

5.1 SOURCE OF SPARE PARTS

Spare parts may be obtained from the manufacturer:

TRONAIR, Inc.	Telephone: (419) 866-6301 or 800-426-6301
1 Air Cargo Pkwy East	Fax: (419) 867-0634
Swanton, Ohio 43558 USA	E-mail: sales@tronair.com
	Website: www.tronair.com

For Spare Parts, Operations & Service Manuals or Service Needs:
Scan the QR code or visit Tronair.com/aftermarket

5.2 RECOMMENDED SPARE PARTS LISTS

Reference the following page(s) for Replacement Parts and Kits available.

Recommended Spares to be kept on hand:

- G-1300-19040 Roll Pin
- G-1310-0415 Ball Lok-T Pin
- K-1401 Kit, Ball Lok-T Pin Replacement
- K-1548 Kit, Bolt/Washer Replacement

6.0 IN-SERVICE SUPPORT

Contact Tronair for technical services and information.

7.0 GUARANTEES/LIMITATION OF LIABILITY

Tronair products are warranted to be free of manufacturing or material defects for a period of one year after shipment to the original customer. This is solely limited to the repair or replacement of defective components. This warranty does not cover the following items:

- a) Parts required for normal maintenance
- b) Parts covered by a component manufacturers warranty
- c) Replacement parts have a 90-day warranty from date of shipment

If you have a problem that may require service, contact Tronair immediately. Do not attempt to repair or disassemble a product without first contacting Tronair, any action may affect warranty coverage. When you contact Tronair be prepared to provide the following information:

- a) Product Model Number
- b) Product Serial Number
- c) Description of the problem

If warranty coverage is approved, either replacement parts will be sent or the product will have to be returned to Tronair for repairs. If the product is to be returned, a Return Material Authorization (RMA) number will be issued for reference purposes on any shipping documents. Failure to obtain a RMA in advance of returning an item will result in a service fee. A decision on the extent of warranty coverage on returned products is reserved pending inspection at Tronair. Any shipments to Tronair must be shipped freight prepaid. Freight costs on shipments to customers will be paid by Tronair on any warranty claims only. Any unauthorized modification of the Tronair products or use of the Tronair products in violation of cautions and warnings in any manual (including updates) or safety bulletins published or delivered by Tronair will immediately void any warranty, express or implied.

The obligations of Tronair expressly stated herein are in lieu of all other warranties or conditions expressed or implied. **Any unauthorized modification of the Tronair products or use of the Tronair products in violations of cautions and warnings in any manual (including updates) or safety bulletins published or delivered by Tronair will immediately void any warranty, express or implied and Tronair disclaims any and all liability for injury (WITHOUT LIMITATION and including DEATH), loss or damage arising from or relating to such misuse.**

Parts List

When ordering replacement parts/kits, please specify model, serial number and color of your unit.

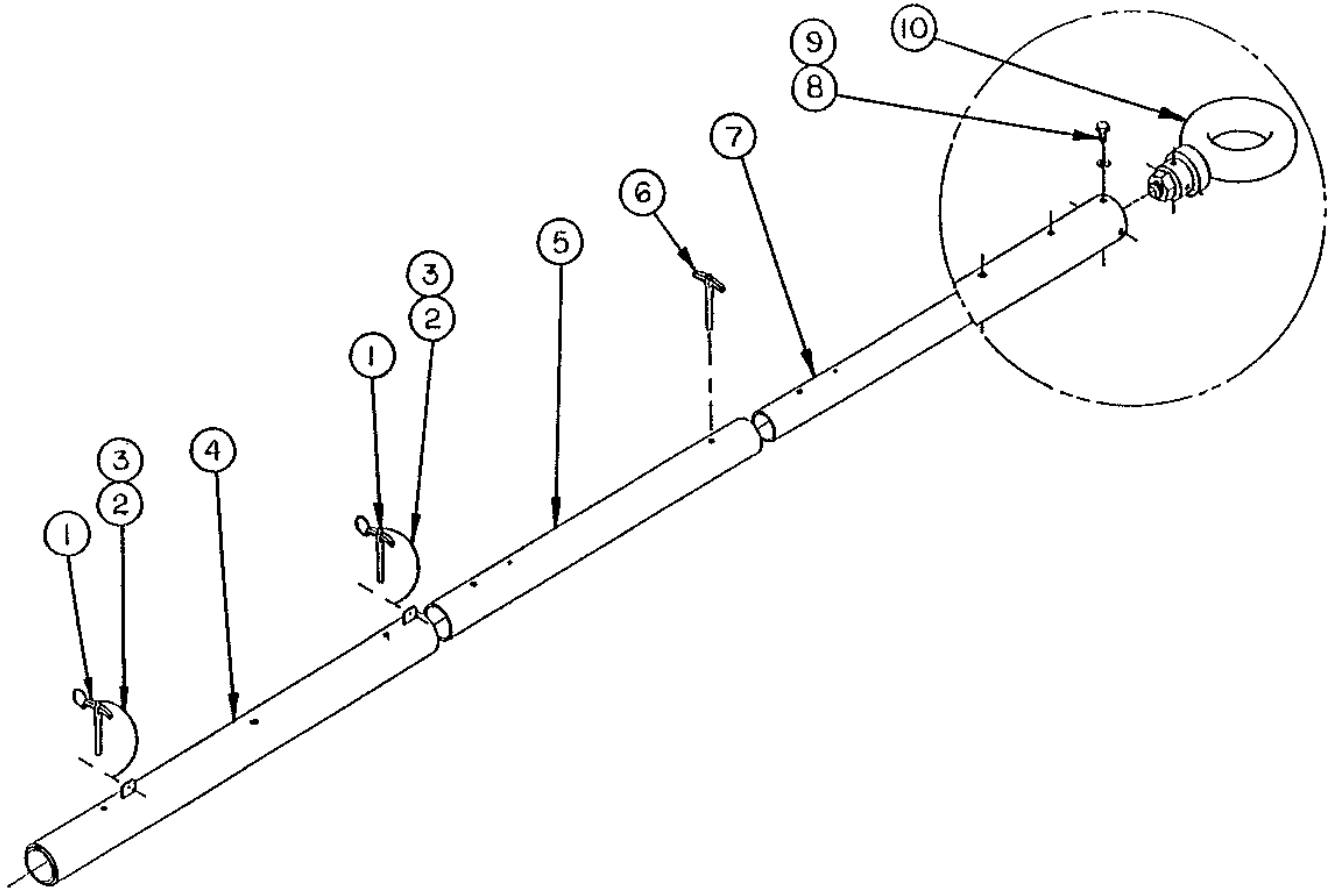

Item	Part Number	Description	Qty
4	Z-1536-01	ASSEMBLY, OUTER TUBE	1
5	TR-1148-01	TUBE, MIDDLE	1
6	G-1310-0835	PIN, BALL LOK-T, 1/2" DIAMETER X 4.5" GRIP	1
7	TR-1149-01	TUBE, INNER	1
	K-1401	BALL LOK-T PIN ASSEMBLY ; consists of:	
1	G-1310-0845	PIN, BALL LOK-T, 1/2" DIAMETER X 4.5" GRIP	1
2	G-1351-04	RIVET, 1/8 OPEN-END STEEL	1
3	H-1026*07.0	ASSEMBLY, LANYARD	1
	K-1548	BOLT/WASHER ASSEMBLY ; consists of:	
8	G-1420-106006	BOLT, HEX HEAD, GRADE 8, 5/16-18 X 3/4" LONG	4
9	G-1251-1060R	LOCKWASHER, 5/16 REGULAR	4
	K-1461	EYEBOLT ASSEMBLY ; consists of:	
8	G-1420-106006	BOLT, HEX HEAD, GRADE 8, 5/16-18 X 3/4" LONG	4
9	G-1251-1060R	LOCKWASHER, 5/16 REGULAR	4
10	Z-1537	WELDMENT, EYEBOLT	1

Parts List

When ordering replacement parts/kits, please specify model, serial number and color of your unit.

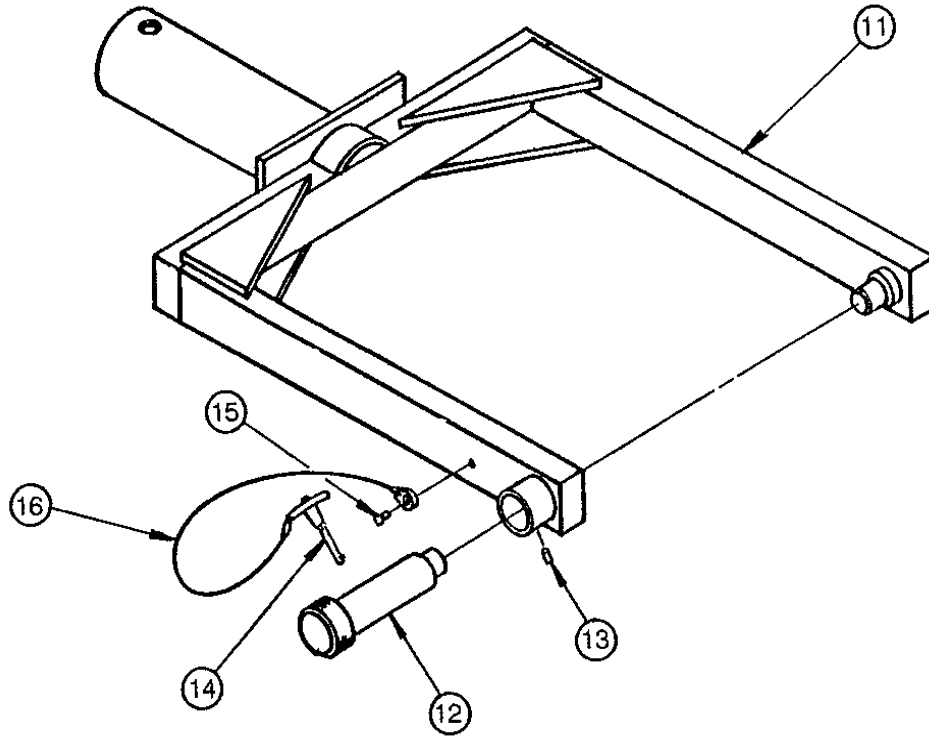

Item	Part Number	Description	Qty
	X-1223	ASSEMBLY, HEAD (INCLUDES ITEMS 11 TO 16)	
11	Z-8283-01	WELDMENT, HEAD	1
12	R-2815	PIN, SLIDING	1
13	G-1300-19040	PIN, ROLL, 3/16" DIAMETER X 1/2" LONG	1
14	G-1310-0415	PIN, BALL LOK-T PIN, 1/4" DIAMETER X 1.5" GRIP	1
15	G-1351-04	RIVET, 1/8 OPEN-END STEEL	1
16	H-1026*07.0	ASSEMBLY, LANYARD	1



APPENDIX I

Declaration of Conformity

[Click here to visit PilotJohn.com](http://PilotJohn.com)



EU Declaration of Conformity

Model Number(s) 01-1374-0000

Product Type/Name: 12 Ton (11 Metric Ton) Single Stage Jack

Serial Number(s): Enter serial number(s)

Declaration: Tronair has assessed the equipment described above against the Essential Health and Safety Requirements of one or more Directives. Based on this assessment, the equipment described above is deemed to comply with the directive(s) listed below.

This declaration of conformity is issued under the sole responsibility of the manufacturer.

Directives: European Machinery Directive 2006/42/EC

Standards: EN ISO 12100-1 Safety of machinery – General principles for design – Basic terminology, methodology

Markings: 

The technical documentation for the machinery is available from:

Mr. Joel Nunn
34 Epirus Road, SW6 7UH, London, UK
Email: jnunn@tronair.com

Location of Issue: Tronair, 1 Air Cargo Parkway East, Swanton, OH 43558

Certificate: EU_DoC_01-1374-0000

Identification of person empowered to sign on behalf of the Manufacturer:

Quality Assurance Representative

Enter a date
Date



[Click here to visit PilotJohn.com](http://PilotJohn.com)



Maintenance Schedule

Universal Portable Towbars

Models: 01-1215-0000, 01-1216-0000

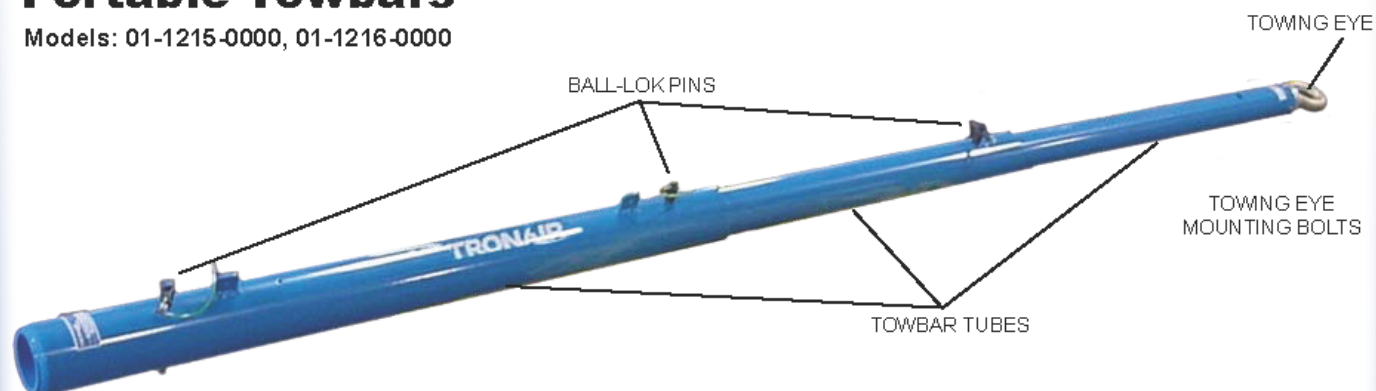

Tronair recommends towbar inspections at least once a week.

- ❑ Check towing eye for bending, excessive wear and deformity. If any are located, remove towbar from service and contact Tronair for repair.
- ❑ Check towing eye mounting bolts. Ensure the fasteners are tight and not missing. Tighten to 25 ft-lbs or replace as required.
- ❑ Inspect the towbar tube for cracks, gouges greater than 1/16", and bends or deformities. If any are located, remove towbar from service and contact Tronair for repair.
- ❑ Check the towbar tubes to ensure they slide within each other as intended. If the tubes bind, it indicates that bending has occurred. Remove towbar from service and contact Tronair or your Tronair distributor for replacement of bent section(s).
- ❑ Inspect ball-lok pins for bending or unusual wear. Verify the factory supplied pin is used. Contact Tronair or your Tronair distributor for replacement if required. Use only Tronair specified ball-lok pins.
- ❑ Ensure the ball-lok pins are connected to the towbar via their lanyards (if applicable). Replace lanyard(s) if missing.

INS-1791

www.tronair.com

Tronair • Email: sales@tronair.com • Phone: 419-866-6301 or 800-426-6301 • Fax: 419-867-0634

Asia Sales Offices: China - Email: tronairchina@tronair.com • Phone: 86-592-5560735 • Fax: 86-592-5563132

Asia/Australia - Email: tronairasia@tronair.com • Phone: 66-2665-6511 • Fax: 66-2204-1858

Europe, Middle East & Africa Sales Office • Email: saleseurope@tronair.com • Phone: 44-0-113-245-3300 • Fax: 44-0-113-322-0436

[Click here to visit PilotJohn.com](http://PilotJohn.com)



Maintenance Schedule

Standard Attachment Heads

Models:

01-0506-0000, 01-0507-0000, 01-0508-0000,
 01-0511-0000, 01-0513-0000, 01-0514-0000,
 01-0516-0000, 01-0518-0000, 01-0518-0010,
 01-0524-0000, 01-0525-0000, 01-0529-0000,
 01-0531-0000, 01-0532-0000, 01-0534-0000,
 01-0538-0000, 01-0540-0000, 01-0540-0010,
 01-0542-0000, 01-0542-0010, 01-0543-0000,
 01-0545-0000, 01-0545-0010, 01-0545-0011,
 01-0546-0000, 01-0547-0000, 01-0551-0000,
 01-0551-0010, 01-0552-0000, 01-0552-0010,
 01-0552-0011, 01-0556-0000, 01-0569-0000,
 01-0570-0000, 01-0570-0010, 01-0571-0000,
 01-0571-0010, 01-0571-0011, 01-0577-0000,
 01-0577-0010, 01-0579-0000, 01-0581-0000,
 01-0582-0000, 01-0582-0010, 01-0582-0000,
 01-0582-0011, 01-0597-0000, 01-0598-0000,
 01-0599-0000, 01-0801-0000, 01-0801-0010,
 01-0802-0000, 01-0802-0010, 01-0803-0000,
 01-0600-0000, 01-0608-0000

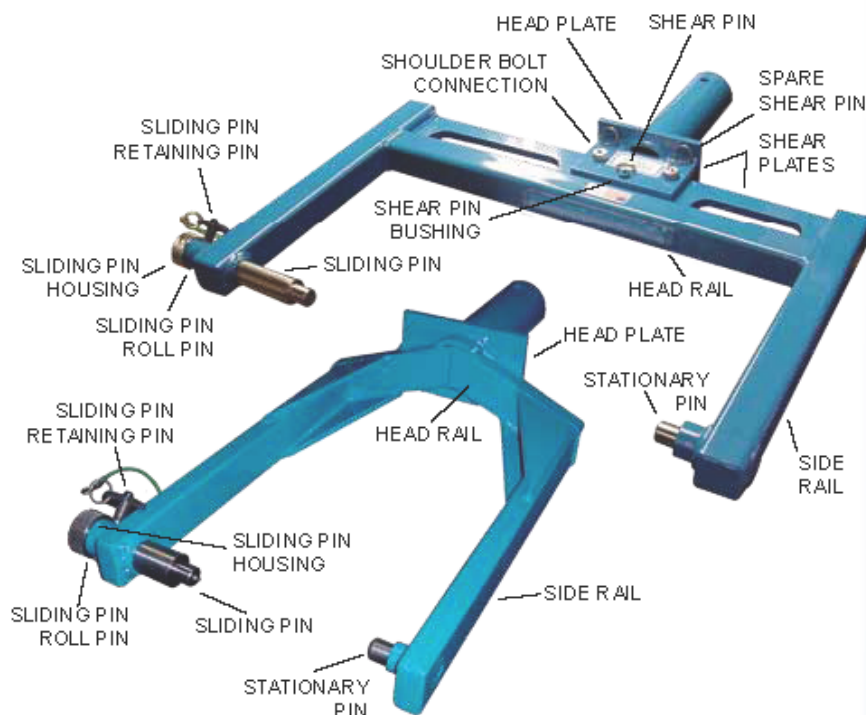

Tronair recommends towbar inspections at least once a week.

- Inspect for weld cracks. If found remove the towbar multi-head from service and contact Tronair for repair.
- Inspect the side rails, head rail, and head plate for bending. If found remove the towbar multi-head from service and contact Tronair for repair.
- For towbar multi-heads with shear, inspect the shear plates for bending. If found remove the towbar multi-head from service and contact Tronair for repair.
- Inspect the sliding pin(s) and (if applicable) the stationary pin for bending, cracks, and excessive wear. If found remove the towbar multi-head from service and contact Tronair or your Tronair distributor for replacement.
- Ensure the sliding pin(s) can move freely within its housing. If any binding occurs, inspect the sliding pin for bending and the housing for out-of-roundness. If either condition exists, contact Tronair for repair options.
- Inspect the sliding pin retaining pin assembly. Ensure the retaining pin is not missing. Ensure the retaining pin can engage the sliding pin through its housing and that it positively locks the sliding pin into place. If it does not, contact Tronair or your Tronair distributor for replacement/repair.
- Verify the sliding pin is secure to the towbar multi-head via its lanyard. Replace the lanyard if missing.
- Inspect the sliding pin roll pin (located through the sliding pin housing). Ensure the sliding pin roll pin is not loose or missing, contact Tronair or your Tronair distributor for replacement if needed.
- For towbar multi-heads with shear, check the shoulder bolt connections through the shear plates. Verify they are not clamping the shear plates together. There should not be any clamping force applied to the shear plates so the assembly functions properly. If required, back the stopnut off to remove any clamping force applied.
- For towbar multi-heads with shear, inspect the shear pin. If the shear pin is bent, broken, or missing contact Tronair or your Tronair distributor for replacement. Tronair recommends purchasing spare shear pins for rapid replacement, use only Tronair specified shear pins.
- For towbar multi-heads with shear, inspect the shear pin bushings. If the shear pin bushings are cracked or chipped, contact Tronair or your Tronair distributor for replacement, use only Tronair specified shear pin bushings.
- Inspect all steel components for signs of rust. Touch up with paint as required.

INS-1789

www.tronair.com

Tronair • Email: sales@tronair.com • Phone: 419-866-6301 or 800-426-6301 • Fax: 419-867-0634

Asia Sales Offices: China - Email: tronairchina@tronair.com • Phone: 86-592-5560735 • Fax: 86-592-5563132

Asia/Australia - Email: tronairasia@tronair.com • Phone: 66-2665-6511 • Fax: 66-2204-1858

Europe, Middle East & Africa Sales Office • Email: saleseurope@tronair.com • Phone: 44-0-113-245-3300 • Fax: 44-0-113-322-0436