



**Model: KHC-4023**

**Hydraulic Power Unit  
Run-Around Kit**

**\*\*\***

**Parts List**

02/2014 – Rev. 02

**When ordering Replacement Parts/Kits, please specify Model, Color and Serial Number of your Unit.**



This product can not be modified without the written approval of Tronair, Inc. Any modifications done without written approval voids all warranties and releases Tronair, Inc., its suppliers, distributors, employees, or financial institutions from any liability from consequences that may occur. Only Tronair OEM replacement parts shall be used.

### 1.0 HYDRAULIC POWER UNIT SELF-CLEANING PROCEDURE

1. Connect pressure and return hoses from system 1 together using a union or quick disconnect assembly
2. Connect pressure and return hoses from system 2 together using a union or quick disconnect assembly (if applicable)
3. Open return ball valves on systems 1 **and** 2 to maximum position (fully open)
4. Close the pressure valve on system 2 (right system, fully closed) (if applicable)
5. Open the pressure valve on system 1 (left system) to maximum position (fully open)

#### WARNING!



**Failure to open the return ball valves will cause hose or valve rupture. Property damage and personal injury can result.**

6. Turn on HPU, set flow rate to maximum, slowly close bypass valve fully (pressure control will need to be above minimal setting to achieve this flow).
7. Circulate for 15 minutes
8. Open bypass valve, shut off Hydraulic Power Unit
9. Open the pressure valve on system 2 (right system) to maximum position (fully open) (if applicable)
10. Close the pressure valve on system 1 (left system, fully closed)
11. Turn on HPU, slowly close bypass valve fully
12. Circulate for 15 minutes
13. Open bypass valve, shut off Hydraulic Power Unit
14. Take a fluid sample of the Hydraulic Power Unit using ISO 4021 procedure or equivalent. If the particle contamination is above acceptable limits, repeat procedure.
15. Change all Hydraulic Power Unit filters if additional self-cleaning does not produce acceptable particle counts.

**NOTE: This procedure will only reduce the particle count of the fluid. A complete fluid analysis should also check the fluid viscosity, TAN (Total Acid Number), water content, wear metals and additive levels, and a photo analysis. Fluorine and Chlorine levels for Aerospace applications should also be monitored.**

### 2.0 GUARANTEES/LIMITATION OF LIABILITY

Tronair products are warranted to be free of manufacturing or material defects for a period of one year after shipment to the original customer. This is solely limited to the repair or replacement of defective components. This warranty does not cover the following items:

- a) Parts required for normal maintenance
- b) Parts covered by a component manufacturers warranty
- c) Replacement parts have a 90-day warranty from date of shipment

If you have a problem that may require service, contact Tronair immediately. Do not attempt to repair or disassemble a product without first contacting Tronair, any action may affect warranty coverage. When you contact Tronair be prepared to provide the following information:

- a) Product Model Number
- b) Product Serial Number
- c) Description of the problem

If warranty coverage is approved, either replacement parts will be sent or the product will have to be returned to Tronair for repairs. If the product is to be returned, a Return Material Authorization (RMA) number will be issued for reference purposes on any shipping documents. Failure to obtain a RMA in advance of returning an item will result in a service fee. A decision on the extent of warranty coverage on returned products is reserved pending inspection at Tronair. Any shipments to Tronair must be shipped freight prepaid. Freight costs on shipments to customers will be paid by Tronair on any warranty claims only. Any unauthorized modification of the Tronair products or use of the Tronair products in violation of cautions and warnings in any manual (including updates) or safety bulletins published or delivered by Tronair will immediately void any warranty, express or implied.

The obligations of Tronair expressly stated herein are in lieu of all other warranties or conditions expressed or implied. **Any unauthorized modification of the Tronair products or use of the Tronair products in violations of cautions and warnings in any manual (including updates) or safety bulletins published or delivered by Tronair will immediately void any warranty, express or implied and Tronair disclaims any and all liability for injury (WITHOUT LIMITATION and including DEATH), loss or damage arising from or relating to such misuse.**



**Parts List**

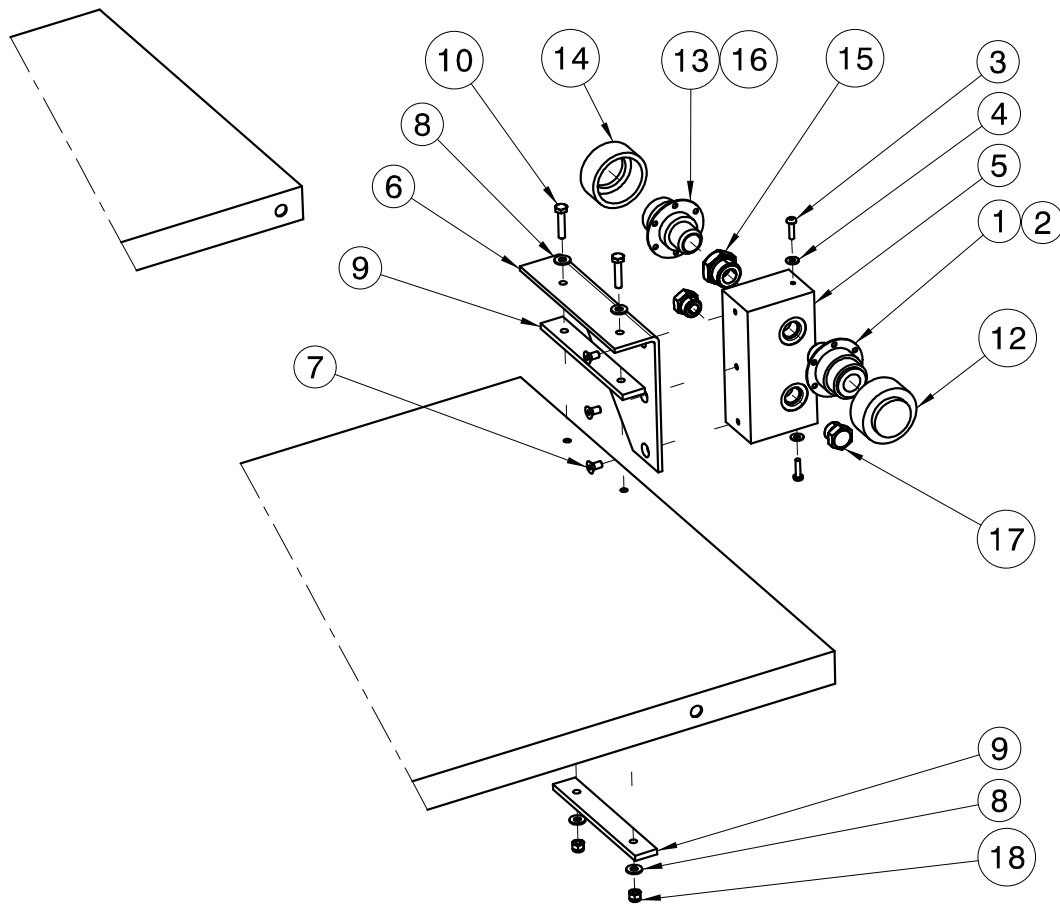

Item	Part Number	Description	Qty
1	N-2856	Coupling Half, Quick Disconnect	1
2	HC-2013-908	O-Ring, Series 3	1
3	G-1157-103006	Screw, #10 – 24 Pan HD CRS REC	2
4	G-1250-1030N	Flatwasher, #10 Narrow	2
5	J-4217	Manifold	1
6	S-2676	Bracket, Manifold	1
7	G-1152-105206	Screw, Soc Flt Hd 82° Cap	3
8	G-1250-1050W	Flatwasher, ¼ Wide	4
9	J-5688-01	Plate, Backer	2
10	G-1100-105012	Bolt, HH Grade 5, ¼ - 20 x 1 ¼ Long	2
12	N-2573-06	Cap, Quick Disconnect	1
13	N-2861	Coupling Half, Quick Disconnect	1
14	N-2702	Cap, Quick Disconnect	1
15	N-2463-06-S-E	Fitting, Expander	1
16	HC-2013-910	O-Ring, Series 3	1
17	N-2053-06-S-E	Plug, O-Ring	1
18	N-2053-05-S-E	Plug, O-Ring	1
19	G-1202-1050	ESN, ¼ - 20	2
Not Shown	V-1967	Label, Warning	1