



# OPERATION & SERVICE MANUAL



**Model: 08T4049-0013  
Engine Compressor Washer**



11/2023 - Rev. 03

REVISION	DATE	TEXT AFFECTED
01	05/2008	Original Release
02	11/2022	Major revision
03	11/2023	Modified 4.1.2 Fluid Agitation, 4.1.3 Cleaning Operation, 4.1.4 Rinse Operation

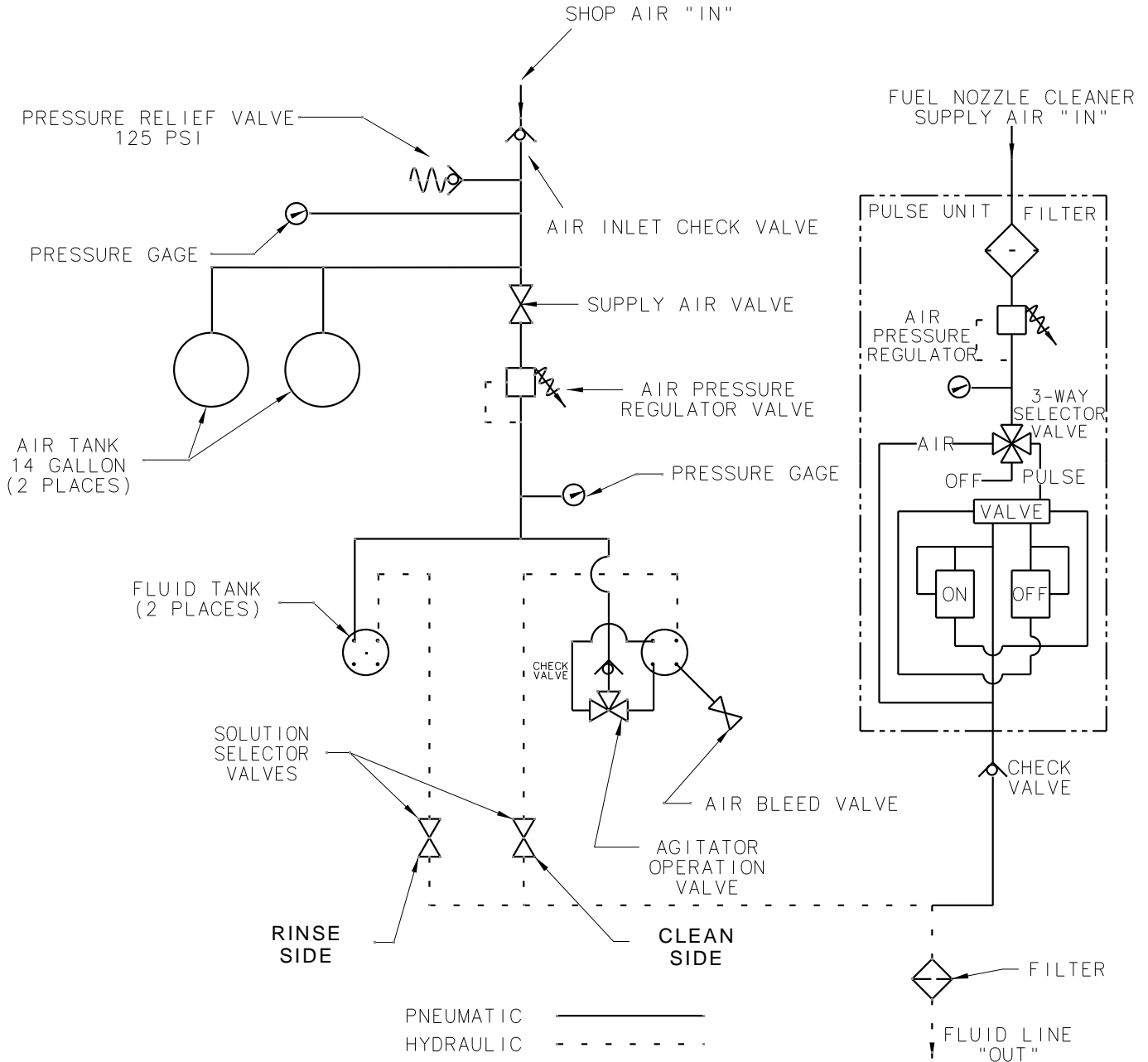

**TABLE OF CONTENTS**

**PAGE**

<b>1.0</b>	<b>PRODUCT INFORMATION .....</b>	<b>2</b>
1.1	DESCRIPTION.....	2
1.2	MODEL & SERIAL NUMBER.....	2
1.3	MANUFACTURER .....	2
<b>2.0</b>	<b>SAFETY INFORMATION.....</b>	<b>2</b>
2.1	USAGE AND SAFETY INFORMATION .....	2
<b>3.0</b>	<b>TRAINING.....</b>	<b>2</b>
3.1	TRAINING REQUIREMENTS .....	2
3.2	TRAINING PROGRAM .....	2
3.3	OPERATOR TRAINING.....	2
<b>4.0</b>	<b>OPERATION.....</b>	<b>3</b>
4.1	PREPARATION & OPERATION .....	3
4.1.1	Preparation .....	3
4.1.2	Fluid Agitation .....	3
4.1.3	Cleaning Operation .....	3
4.1.4	Rinse Operation .....	3
4.2	PT-6 FUEL NOZZLE CLEANING.....	4
<b>5.0</b>	<b>MAINTENANCE &amp; STORAGE .....</b>	<b>4</b>
5.1	CLEANING FLUID TANKS .....	4
5.2	HOSES .....	4
5.3	AIR TANK MAINTENANCE .....	4
5.4	OUTPUT FILTER .....	4
5.5	STORAGE .....	4
<b>6.0</b>	<b>PROVISION OF SPARES.....</b>	<b>5</b>
6.1	SOURCE OF SPARE PARTS.....	5
6.2	RECOMMENDED SPARE PARTS LISTS .....	5
<b>7.0</b>	<b>IN-SERVICE SUPPORT .....</b>	<b>5</b>
<b>8.0</b>	<b>GUARANTEES/LIMITATION OF LIABILITY.....</b>	<b>5</b>
<b>9.0</b>	<b>APPENDICES.....</b>	<b>5</b>

### Schematic



This product can not be modified without the written approval of Tronair, Inc. Any modifications done without written approval voids all warranties and releases Tronair, Inc., its suppliers, distributors, employees, or financial institutions from any liability from consequences that may occur. Only Tronair OEM replacement parts shall be used.

## 1.0 PRODUCT INFORMATION

### 1.1 DESCRIPTION

The Engine Compressor Washer is a portable unit designed to spray cleaning solution and/or clean de-mineralized water into jet and turboprop engines.

The two fluid tanks hold 12 gallons (45.4 L) each. The air tanks, when charged to 125 psi (8.6 bar), provide sufficient volume to empty both fluid tanks. The nozzle mounted on the panel may be installed into the wand to regulate the fluid flow to the approximate rate as indicated.

### 1.2 MODEL & SERIAL NUMBER

Reference nameplate on unit

### 1.3 MANUFACTURER

**TRONAIR**, Inc.  
1 Air Cargo Pkwy East  
Swanton, Ohio 43558 USA

Telephone: (419) 866-6301 or 800-426-6301  
Fax: (419) 867-0634  
E-mail: sales@tronair.com  
Website: www.tronair.com

## 2.0 SAFETY INFORMATION

### 2.1 USAGE AND SAFETY INFORMATION

To insure safe operations please read the following statements and understand their meaning. Also refer to your equipment manufacturer's manual for other important safety information. This manual contains safety precautions which are explained below. Please read carefully.



**WARNING!** — Warning is used to indicate the presence of a hazard that **can cause severe personal injury, death, or substantial property damage** if the warning notice is ignored.

**CAUTION!** — Caution is used to indicate the presence of a hazard that **will or can cause minor personal injury or property damage** if the caution notice is ignored.

## 3.0 TRAINING

### 3.1 TRAINING REQUIREMENTS

The employer of the operator is responsible for providing a training program sufficient for the safe operation of the engine compressor washer.

### 3.2 TRAINING PROGRAM

The employer provided operator training program should cover safety procedures concerning use of the engine compressor washer in and around the intended aircraft at the intended aircraft servicing location.

### 3.3 OPERATOR TRAINING

The operator training should provide the required training for safe operation of the engine compressor washer.

**NOTE: Maintenance and Trouble Shooting are to be performed by a skilled and trained technician.**

## 4.0 OPERATION

### WARNING!



1. Personal injury may result if procedures are not followed.
2. Never open fluid tank while under pressure.
3. Never pressurize air tank more than 125 psi (8.6 bar).

### CAUTION!



1. Use only clean de-mineralized water and/or cleaning fluids approved by engine manufacturer.
2. Consult aircraft maintenance manual for correct procedure in performing engine wash.

## 4.1 PREPARATION & OPERATION

Follow engine manufacturer's recommendations for cleaning and rinsing engine(s). Use only engine manufacturer's approved fluids.

### 4.1.1 Preparation

1. Visually inspect unit for any signs of shipping damage or missing parts.
2. Ensure supply air valve on Control Panel is in the closed (Off) position.
3. Open air bleed to depressurize solution tanks.
4. Remove solution tank lids and fill respective tank with desired amount of fluid.
5. Close solution tank lids.
6. Attach shop air to air fill valve on Control Panel and charge air tanks to 125 psi (8.6 bar) maximum.
7. Unit is now ready for immediate use. If unit stands idle, agitate fluid before use.

### 4.1.2 Fluid Agitation

**NOTE: The valve must either be in the "AGITATE" or "WASH" position to pressurize solution tank.**

1. Fully charge air supply tanks. Turn agitation valve to "AGITATE" and ensure supply air valve is in the off position (closed).
2. Open air bleed valve on top of solution tank.
3. Set regulator to desired agitation pressure (30 psi recommended).
4. Slowly open supply air valve. When suds start coming out of the air bleed valve, or desired agitation is reached, close air bleed valve and turn the agitation valve to "WASH".

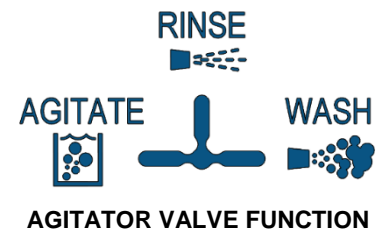

### 4.1.3 Cleaning Operation

1. Ensure tanks are charged and rinse and clean selector valves are closed and agitation valve is set to "WASH."
2. Connect output hose to engine or wand assembly.
3. Open supply air valve.
4. Adjust cleaning pressure by adjusting air regulator on Control Panel per engine manufacturer's recommendations.
5. Turn clean selector valve to Open when ready to start cleaning.
6. If using wand, point wand away from personnel and turn on wand valve to start cleaning process.
7. Upon completion of cleaning (or if tank has been emptied), turn wand valve off and/or close clean selector valve on Control Panel.

### 4.1.4 Rinse Operation

**NOTE: Agitator operation valve must be set to "RINSE" during rinse operation. Failure to do so may result in cleaning solution being discharged during rinse operation.**

1. Adjust rinsing pressure by adjusting air regulator on Control Panel per engine manufacturer's recommendations.
2. Set agitation valve to "RINSE."
3. Turn rinse selector valve to Open position on the Control Panel to start rinse.
4. If using wand, point wand away from personnel and turn on wand valve to start rinse process.
5. After completion of rinsing, turn wand valve Off and/or close rinse selector valve on Control Panel.

**4.2 PT-6 FUEL NOZZLE CLEANING**

1. Prepare engine for fuel nozzle cleaning.
  - a. Connect the PT-6 engine connection assembly, Part Number: Z-2319, to the engine.
  - b. Disconnect spraying wand from the unit supply hose at the quick disconnect fitting.
  - c. Connect the Part Number Z-2319 adapter assembly to the quick disconnect fitting on the unit supply hose.
  - d. With all valves closed or "OFF", connect compressed air supply to fuel nozzle pulse cleaner.
2. Adjust the input pulse air regulator to the desired pressure.
3. Adjust the fluid tank air regulator to the desired pressure.
4. Follow engine maintenance manual recommendations for specific order and duration of pulse cycle steps.
5. The following chart denotes the proper orientation for all valves to perform specific steps of the operation cycle:

**VALVE ORIENTATION FOR CYCLE STEPS**

Cycle Steps	Selector Valve	Supply Air Valve	Clean Valve	Rinse Valve
Detergent Wash	Pulse	Open	Open	Closed
System Rinse	Pulse	Open	Closed	Open
Soak/Off	Off	Closed	Closed	Closed
Air Dry System	Air dry	Closed	Closed	Closed

6. Inject cleaning solution into engine by opening cleaning tank selector valve. Close selector valve when desired amount of cleaning solution has been dispensed.
7. Inject rinsing fluid into engine by opening rinse tank selector valve. Close selector valve when rinse is completed.

**5.0 MAINTENANCE & STORAGE****5.1 CLEANING FLUID TANKS**

**NOTE: For tank cleaning, wand must be attached to output hose to let fluid discharge.**

After each use, complete the following:

1. Close supply air valve.
2. Open air bleed valve, let tanks de-pressurize.
3. Remove cleaning tank lid and fill with approximately one gallon (3.8 L) of water.
4. Close cleaning tank lid and air bleed valve. Open supply air valve.
5. Open clean selector valve and wand valve.
6. Close supply air valve when tank is empty.
7. Close clean selector valve, wand valve. Open air bleed valve.
8. Hydrostatically or pneumatically test tank(s) as required due to physical damage, or as required by local law.

**5.2 HOSES**

Replace worn hoses as required.

**5.3 AIR TANK MAINTENANCE**

Periodically drain air tank by opening plug valve at bottom of air tank to remove any condensation that may have accumulated during use.

Hydrostatically or pneumatically test tank(s) as required due to physical damage, or as required by local law.

**5.4 OUTPUT FILTER**

1. Periodically inspect filter for cleanliness. Clean with fresh water.
2. Replace filter element when fluid flow is hindered.

**5.5 STORAGE**

- Ensure fluid tanks are clean. (Reference Section 3.1)
- Clean the unit exterior prior to storage.
- Depressurize entire unit.

**6.0 PROVISION OF SPARES****6.1 SOURCE OF SPARE PARTS**

Spare parts may be obtained from the manufacturer:

**TRONAIR, Inc.**

1 Air Cargo Pkwy East

Swanton, Ohio 43558 USA

Telephone: (419) 866-6301 or 800-426-6301

Fax: (419) 867-0634

E-mail: sales@tronair.com

Website: www.tronair.com

For Spare Parts, Operations & Service Manuals or Service Needs:  
Scan the QR code or visit Tronair.com/aftermarket**6.2 RECOMMENDED SPARE PARTS LISTS**

Reference the following page(s) for Replacement Parts and Kits available.

**NOTE: No user serviceable parts are in the air pulsation unit. Unit must be returned to factory for servicing.****7.0 IN-SERVICE SUPPORT**

Contact Tronair for technical services and information.

**8.0 GUARANTEES/LIMITATION OF LIABILITY**

Tronair products are warranted to be free of manufacturing or material defects for a period of one year after shipment to the original customer. This is solely limited to the repair or replacement of defective components. This warranty does not cover the following items:

- a) Parts required for normal maintenance
- b) Parts covered by a component manufacturers warranty
- c) Replacement parts have a 90-day warranty from date of shipment

If you have a problem that may require service, contact Tronair immediately. Do not attempt to repair or disassemble a product without first contacting Tronair, any action may affect warranty coverage. When you contact Tronair be prepared to provide the following information:

- a) Product Model Number
- b) Product Serial Number
- c) Description of the problem

If warranty coverage is approved, either replacement parts will be sent or the product will have to be returned to Tronair for repairs. If the product is to be returned, a Return Material Authorization (RMA) number will be issued for reference purposes on any shipping documents. Failure to obtain a RMA in advance of returning an item will result in a service fee. A decision on the extent of warranty coverage on returned products is reserved pending inspection at Tronair. Any shipments to Tronair must be shipped freight prepaid. Freight costs on shipments to customers will be paid by Tronair on any warranty claims only. Any unauthorized modification of the Tronair products or use of the Tronair products in violation of cautions and warnings in any manual (including updates) or safety bulletins published or delivered by Tronair will immediately void any warranty, express or implied.

The obligations of Tronair expressly stated herein are in lieu of all other warranties or conditions expressed or implied. **Any unauthorized modification of the Tronair products or use of the Tronair products in violations of cautions and warnings in any manual (including updates) or safety bulletins published or delivered by Tronair will immediately void any warranty, express or implied and Tronair disclaims any and all liability for injury (WITHOUT LIMITATION and including DEATH), loss or damage arising from or relating to such misuse.****9.0 APPENDICES**

APPENDIX I Instrument Certification Notice

APPENDIX II Declaration of Conformity

### Parts List

When ordering replacement parts/kits, please specify model, serial number and color of your unit.

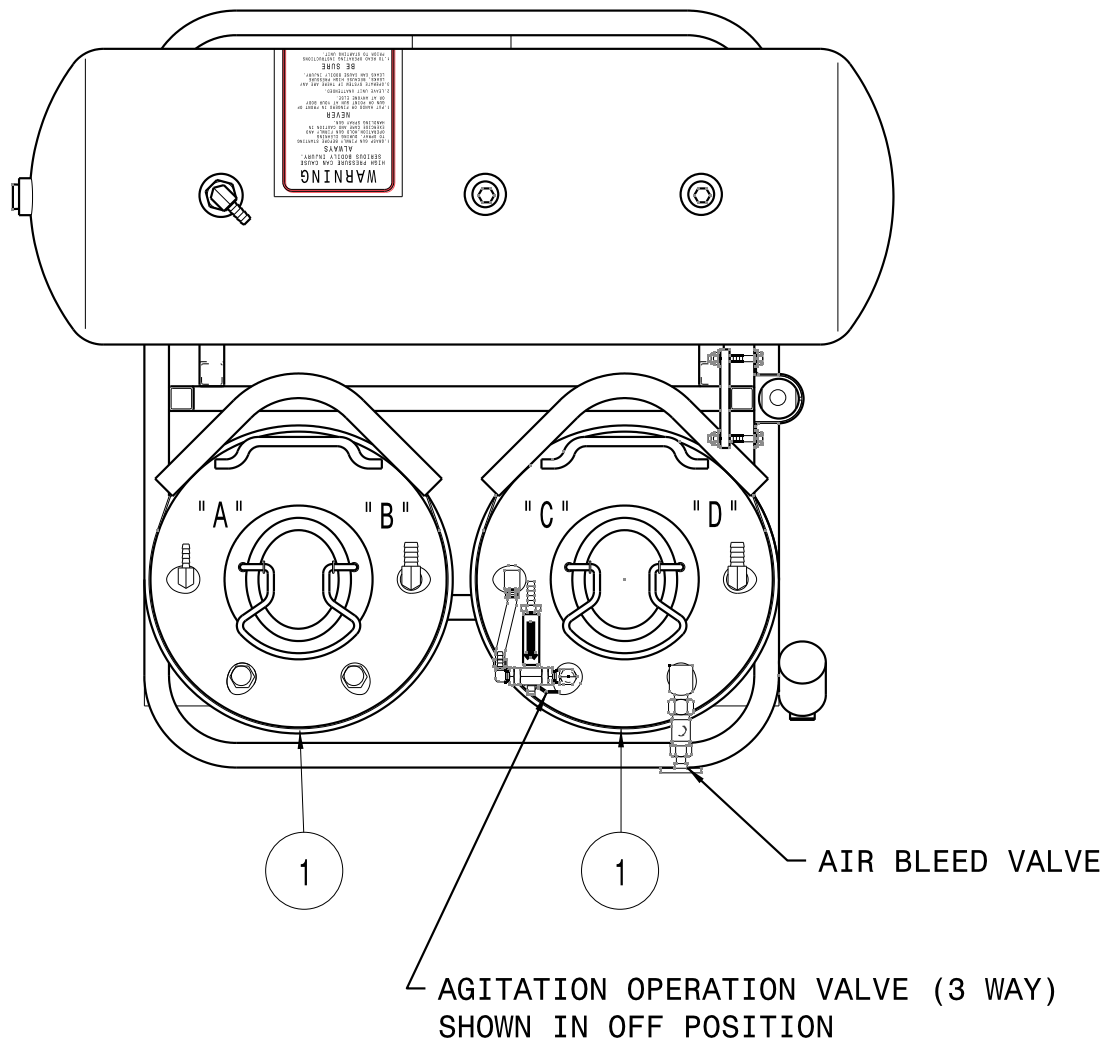

Item	Part Number	Description	Qty
1	B-405	VESSEL, PRESSURE	2
N/S	HC-1400	O-RING, CLOSURE	2
N'S	Z-11842	KIT, LID REPLACEMENT ASSEMBLY	

### Parts List

When ordering replacement parts/kits, please specify model, serial number and color of your unit.

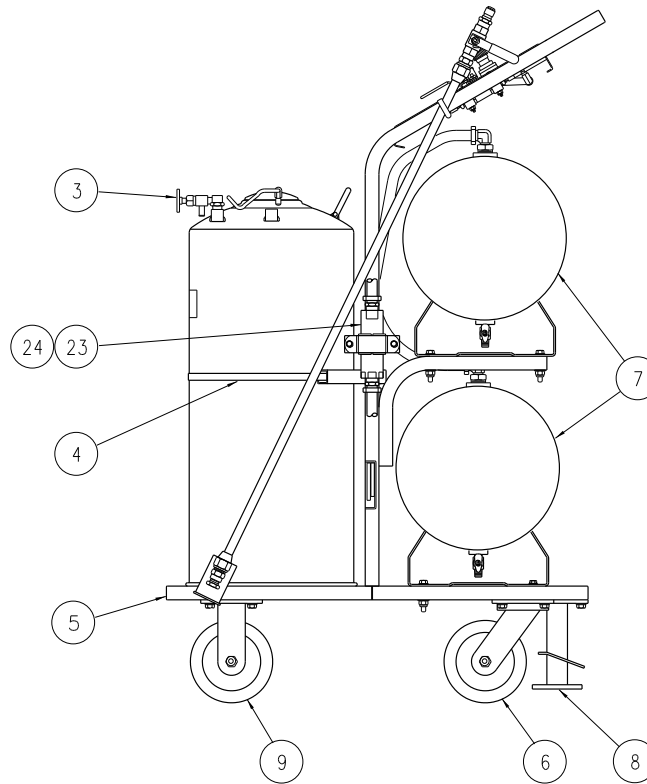

Item	Part Number	Description	Qty
3	H-1529-01	VALVE, SHUT-OFF	1
4	H-1550-14	CLAMP, SNAPLOCK	2
5	Z-4346-01	WELDMENT, FRAME	1
7	PC-1080-01	TANK, AIR	2
23	H-2792	FILTER, OUTPUT	1
24	H-2808	ELEMENT, REPLACEMENT	Ref
6	<b>K-2291</b>	<b>KIT, SWIVEL CASTER REPLACEMENT</b> ; consists of:	6
	U-1014	CASTER, SWIVEL	1
	G-1180-107006	SCREW, 3/8 HEX HEAD, TPG. TYPE F	4
	G-1250-1070N	FLATWASHER, 3/8 NARROW	4
	G-1251-1070R	LOCKWASHER, 3/8 REGULAR	4
8	<b>K-2292</b>	<b>KIT, FLOOR LOCK REPLACEMENT</b> , consists of:	
	H-1175	LOCK, FLOOR	1
	G-1180-107006	SCREW, 3/8 HEX HEAD, TPG. TYPE F	3
	G-1250-1070N	FLATWASHER, 3/8 NARROW	3
	G-1251-1070R	LOCKWASHER, 3/8 REGULAR	3
9	<b>K-2293</b>	<b>KIT, RIGID CASTER ASSEMBLY REPLACEMENT</b> ; consists of:	
	U-1013	CASTER	1
	G-1180-107006	SCREW, 3/8 HEX HEAD, TPG. TYPE F	3
	G-1250-1070N	FLATWASHER, 3/8 NARROW	3
	G-1251-1070R	LOCKWASHER, 3/8 REGULAR	3

### Parts List

When ordering replacement parts/kits, please specify model, serial number and color of your unit.

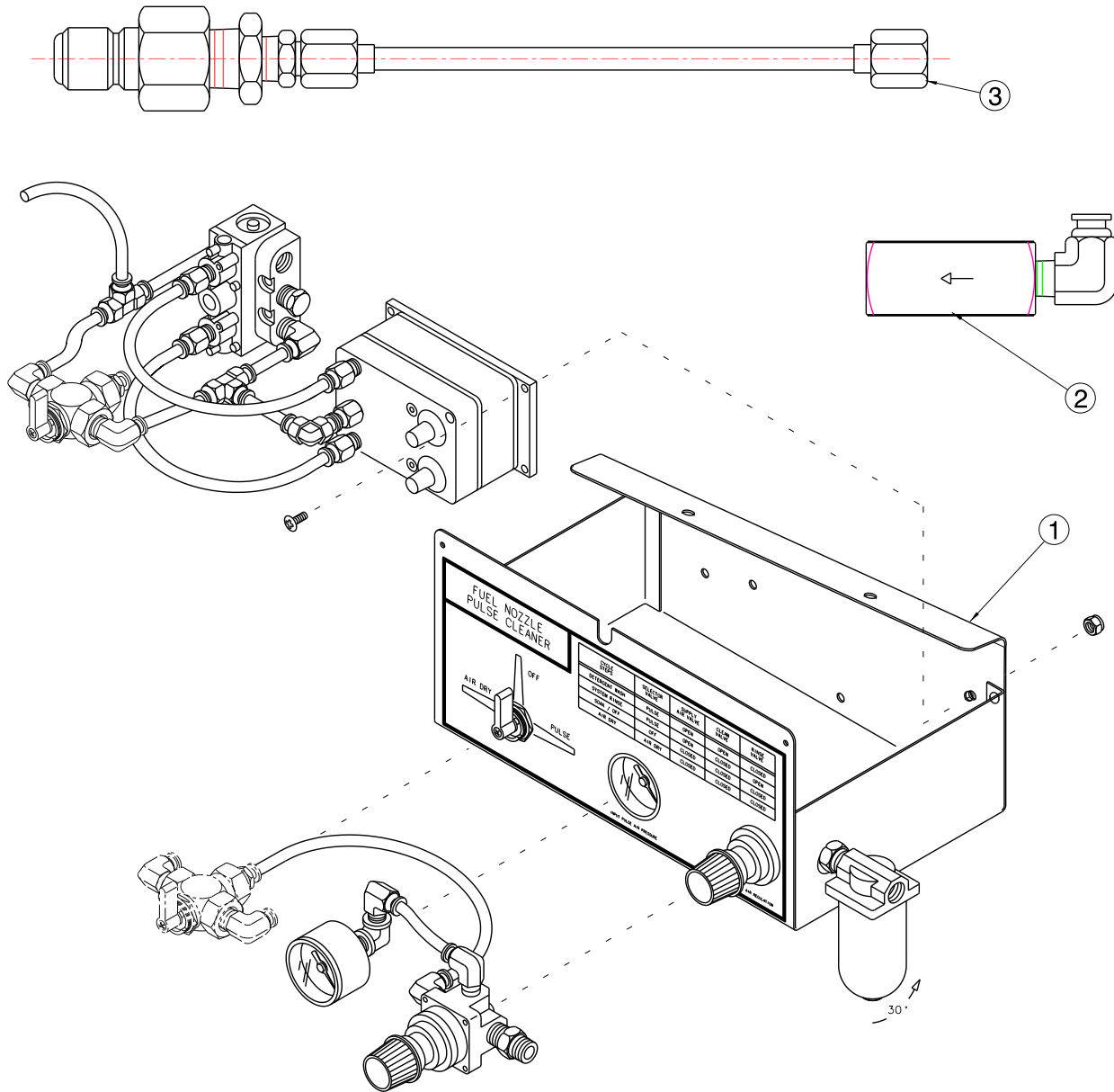

Item	Part Number	Description	Qty
	<b>Z-6873</b>	<b>OPTION 5, FUEL NOZZLE CLEANING;</b> consists of:	
1	Z-6872	ASSEMBLY, FUEL NOZZLE CLEANING	1
2	Z-2318	ASSEMBLY, PANEL ADAPTOR	1
3	Z-2319	ASSEMBLY, PT-6 ENGINE CONNECTION	1
N/S	G-1179-103004	SCREW, #10 PAN HD CR REC TPG	2
N/S	G-1250-1030N	FLATWASHER, #10 NARROW	2
N/S	N-2201-04-B	UNION	1

### Parts List

When ordering replacement parts/kits, please specify model, serial number and color of your unit.

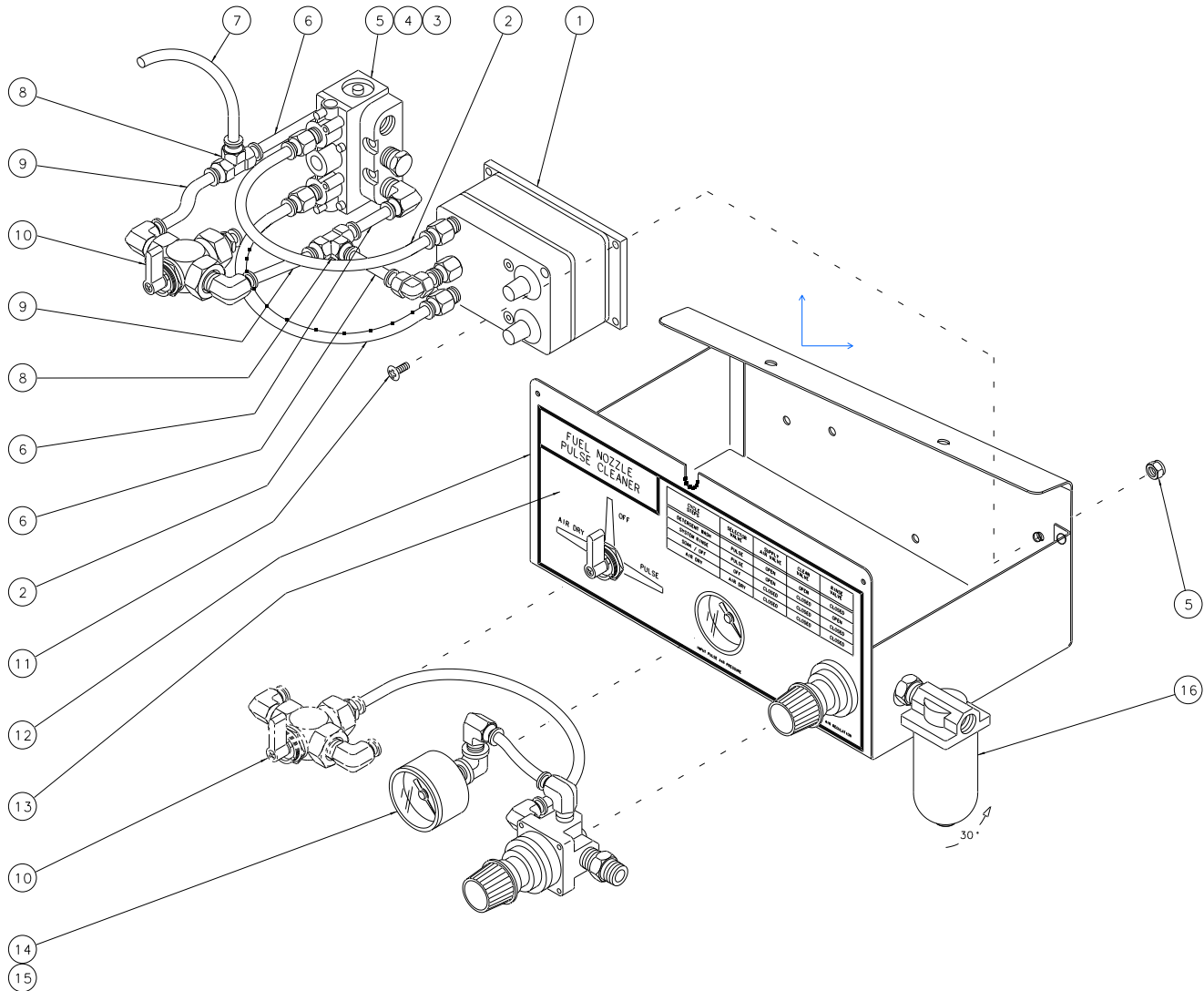

Item	Part Number	Description	Qty
	<b>Z-6872</b>	<b>ASSEMBLY, FUEL NOZZLE CLEANING</b> ; consists of:	
1	Z-2313	ASSMEBLY, OSCILLATOR	1
2	TF-1012*10.3	HOSE, ¼ POLYETHYLENE X 10 ¼ LG	2
3	Z-2310	ASSEMBLY, VALVE	1
4	G-1159-103512	SCREW, RD HD CR REC, 10-32 X 1 ¼ LG	2
5	G-1202-1035	STOPNUT, ELASTIC, 10-32	4
6	TF-1012*02.3	HOSE, ¼ POLYETHYLENE X 2 ¼ LG	3
7	TF-1012*09.0	HOSE, ¼ POLYETHYLENE X 9 LG	1
8	N-2458-03	TEE, UNION, ¼ HOSE	2
9	TF-1012*01.5	HOSE, ¼ POLYETHYLENE X 1 ½ LG	2
10	Z-2312	ASSEMBLY, 3 WAY VALVE	1
11	G-1159-103506	SCREW, RD HD CR REC, 10-32 X ¾ LG	2
12	Z-6871-01	WELDMENT, BOX	1
13	V-1420	LABEL, FUEL NOZZLE CLEANING	1
14	Z-2311	ASSEMBLY, REGULATOR	1
15	H-1426-06	CLAMP, HOSE	1
16	H-1775	FILTER, AIR	1

### Parts List

When ordering replacement parts/kits, please specify model, serial number and color of your unit.

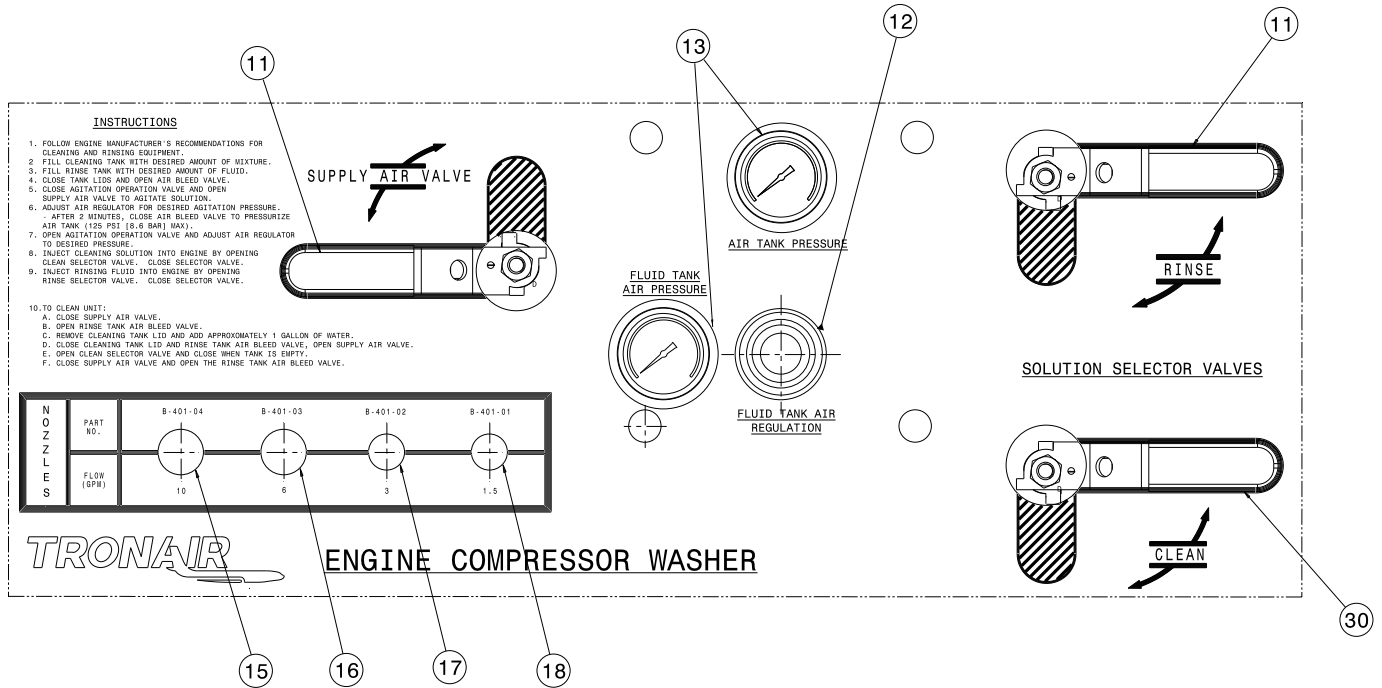

Item	Part Number	Description	Qty
11	HC-2416	VALVE, BALL	2
12	H-3033	REGULATOR	1
13	HC-1831	GAUGE, PRESSURE	2
15	B-401-04	3/8 NOZZLE, 10 GPM	1
16	B-401-03	3/8 NOZZLE, 6 GPM	1
17	B-401-02	1/4 NOZZLE, 3 GPM	1
18	B-401-01	1/4 NOZZLE, 1.5 GPM	1
30	HC-2350-03	VALVE, BALL 1/2 NPT	1

### Parts List

When ordering replacement parts/kits, please specify model, serial number and color of your unit.

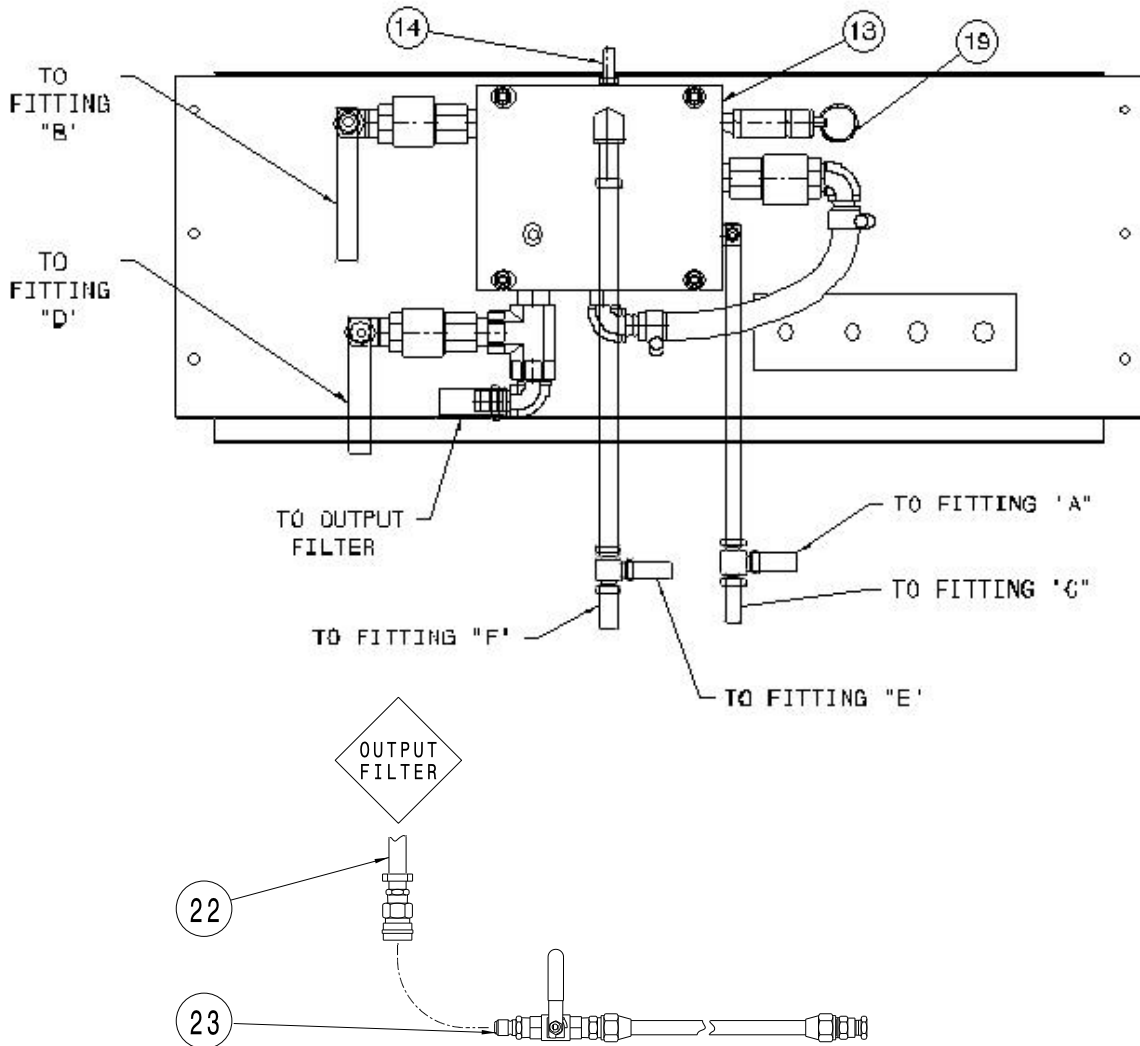

Item	Part Number	Description	Qty
13	J-4306	MANIFOLD	1
14	H-3208	VALVE AIR, ¼ NPT	1
19	PC-1017-02-125	VALVE SAFETY, 125 PSI	1
22	<b>K-1410</b>	<b>KIT, HOSE ASSEMBLY REPLACEMENT</b> ; consists of:	
	TF-1064-08*240	HOSE, 20 FT YELLOW	1
	H-1426-02	CLAMP, HOSE	1
	H-1516-13	CLAMP, 2 EAR HOSE	1
	N-2402-041-B	SOCKET, FEMALE	1
	N-2412-16	CONNECTOR, STRAIGHT MALE	1
23	<b>K-1411</b>	<b>KIT, WAND ASSEMBLY REPLACEMENT</b> ; consists of:	
	Z-1890	ASSEMBLY, TUBE WAND	1
	HC-1137	VALVE, BALL	1
	N-2009-16-B	CONNECTOR, MALE	1
	N-2010-13-B	CONNECTOR, FEMALE	1
	N-2210-05-B	REDUCER, PIPE THREAD	1
	N-2403-04-B	PLUG, MALE THREAD	1

**Parts List**

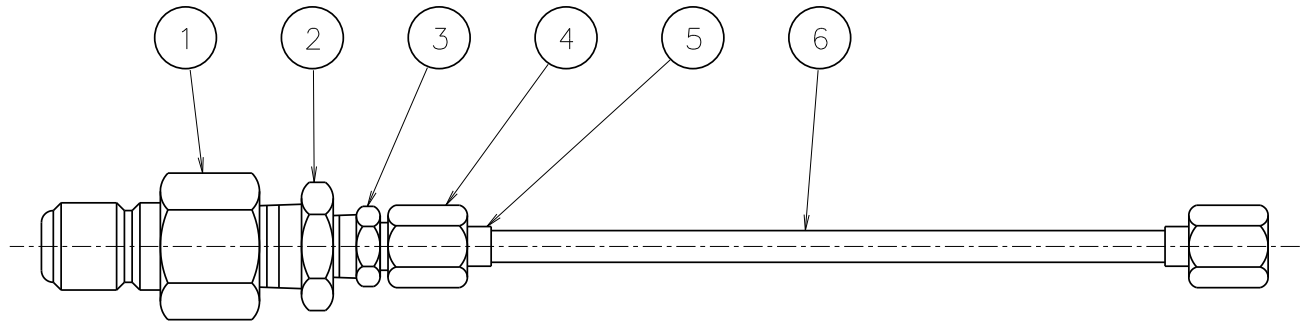

Item	Part Number	Description	Qty
	<b>Z-2319</b>	<b>ASSEMBLY, PT-6 ENGINE CONNECTION;</b> consists of:	
1	N-2401-04-B	PLUG, FEMALE THREAD ½ NPT	1
2	N-2210-08-B	REDUCER, PIPE THREAD ½ MALE X ¼ FEMALE	1
3	N-2009-04-S	CONNECTOR, MALE ¼ NPT X #4	1
4	N-2000-03-S	NUT, 37° FLARE #4	2
5	N-2019-03-S	SLEEVE	2
6	TR373-05*006.00	TUBING, STAINLESS, ¼ OD, .049 WALL X 6 LG	1

**Parts List**

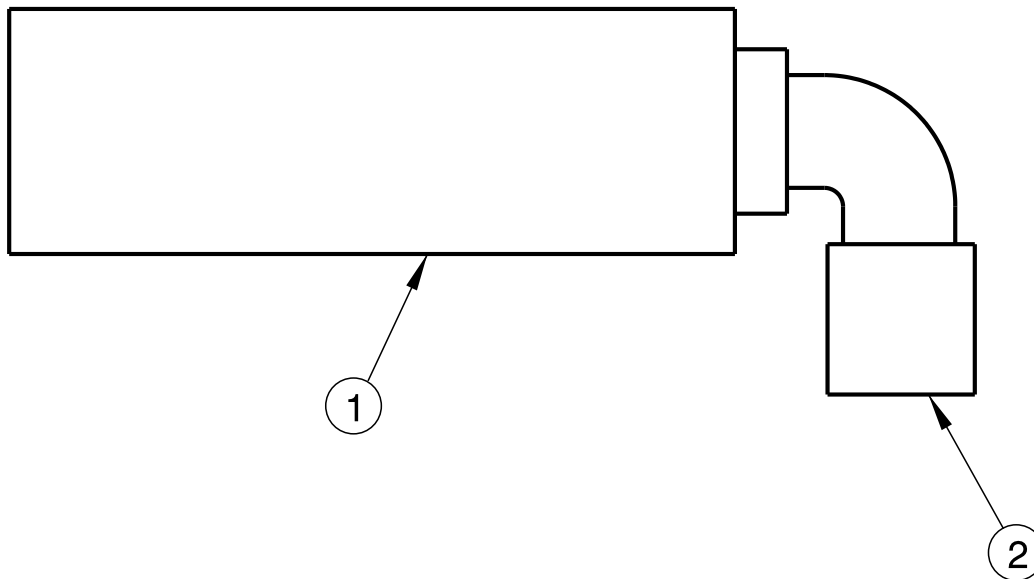

Item	Part Number	Description	Qty
	<b>Z-2318</b>	<b>ASSEMBLY, PANEL ADAPTOR;</b> consists of:	
1	H-1773-02	VALVE, CHECK ¼ NPT	1
2	N-2446-05	ELBOW, 90° MALE, ¼ TUBE X ¼ NPT	1

**Optional Adapter Kits**

When ordering replacement parts/kits, please specify model, serial number and color of your unit.

Part Number	Application
K-1037	DEHAVILLAND DASH 7
K-1057	GARRETT TPE331
K-1152	PRATT & WHITNEY PT6A
K-1243	CESSNA CARAVAN
K-1357	SAAB 340
K-1709	DEHAVILLAND DHC6
K-1710	CANADAIR CHALLENGER
K-1953	ALLISON 250 - C20J, BELL 206 - JR3
K-1269	BEECH KING AIR 200
K-2248	GENERAL ELECTRIC CFM56



## **APPENDIX I**

### **Instrument Certification Notice**





## Instrument Certification Notice

The gauge Certificates of Calibration supplied for the gauge(s) on this unit contain the calibration data for the actual instrument calibrated, along with the calibration date of the **STANDARD** used to perform the calibration check.

The due date for re-calibration of the instrument should be based upon the date the instrument was placed in service in your facility. Re-calibration should be done on a periodic basis as dictated by the end user's quality system or other overriding requirements.

Note that Tronair, Inc. does not supply certificates of calibration on flow meters or pyrometers unless requested at the time of placed order. These instruments are considered reference indicators only and are not critical to the test(s) being performed on the aircraft.





## **APPENDIX II**

### **Declaration of Conformity**





# EU Declaration of Conformity

**Model Number(s)** 08T4049-0013

**Product Type/Name:** Engine Compressor Washer

**Serial Number(s):** Enter serial number(s)

**Declaration:** Tronair has assessed the equipment described above against the Essential Health and Safety Requirements of one or more Directives. Based on this assessment, the equipment described above is deemed to comply with the directive(s) listed below.

This declaration of conformity is issued under the sole responsibility of the manufacturer.

**Directives:** European Machinery Directive 2014/68/EU

European Machinery Directive 2014/29/EU

**Standards:** EN ISO 12100:2011 Safety of machinery – General principles for design – Risk assessment and risk reduction

**Markings:**



**The technical documentation for the machinery is available from:**

RAUH Hydraulic GmbH  
Hallstadler Straße 63  
Email: [tronair@rauh-hydraulik.de](mailto:tronair@rauh-hydraulik.de)

**Location of Issue:** Tronair, 1 Air Cargo Parkway East, Swanton, OH 43558

**Identification of person empowered to sign on behalf of the Manufacturer:**

*Patrick Finch*  
Quality Assurance Representative

Enter a date

Date

