

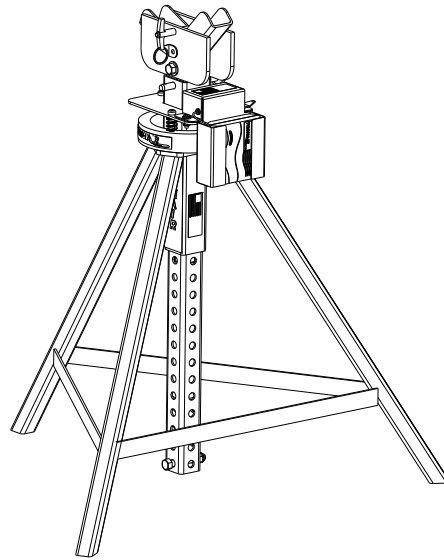

OPERATION & SERVICE MANUAL



Model: 03A5815C0010
Tailstand with Alarm



07/2023 – Rev. 02

REVISION	DATE	TEXT AFFECTED
OR	08/06	Original Release
01	10/06	Modified Parts List – Item 34
02	07/2023	Major revision

TABLE OF CONTENTS**PAGE**

1.0	PRODUCT INFORMATION	1
1.1	DESCRIPTION.....	1
1.2	MODEL & SERIAL NUMBER.....	1
1.3	MANUFACTURER	1
2.0	SAFETY INFORMATION	1
2.1	USAGE AND SAFETY INFORMATION	1
2.2	ALARM AND WARNING SYSTEMS.....	1
2.3	COMPONENT SAFETY FEATURES.....	1
2.4	ENVIRONMENTAL SAFETY FEATURES	1
2.5	CLOSED CIRCUITS	1
2.6	NECESSARY PERSONAL PROTECTIVE EQUIPMENT	1
2.7	SAFETY GUIDELINES	2
2.8	CONDITIONS FOR SAFE USE	2
2.9	OPERATOR QUALIFICATIONS	2
2.10	ADDITIONAL SAFETY MEASURES.....	2
3.0	TRAINING	2
3.1	TRAINING REQUIREMENTS	2
3.2	TRAINING PROGRAM	2
3.3	OPERATOR TRAINING	2
4.0	ASSEMBLY	3
4.1	GENERAL INSTRUCTIONS	3
4.2	PRE-USE CHECKS	3
4.3	PERSONNEL REQUIREMENTS	3
4.4	ASSEMBLY STEPS	3
4.5	INSPECTION AND TEST PROCEDURES	3
5.0	OPERATION	4
5.1	NUMERICAL VALUES.....	4
5.2	OPERATING INSTRUCTIONS	4
5.2.1	Rules For Operating.....	4
5.2.2	Operation	4
5.2.3	Alarm Test.....	4
5.2.4	Battery Test.....	4
5.2.5	Low Battery Warning.....	4
5.2.6	Alarm Load Test.....	4
5.2.7	Tailstand Instructions	5
6.0	PACKAGING AND STORAGE	6
6.1	PACKAGING REQUIREMENTS	6
6.2	HANDLING	6
6.3	STRAPPING	6
6.4	PACKAGING PROTECTION	6
6.5	LABELING OF PACKAGING	6
6.6	STORAGE ENVIRONMENT	6
6.7	STORAGE SPACE AND HANDLING FACILITIES:	6
7.0	TRANSPORTATION	6
8.0	TROUBLESHOOTING	6
9.0	MAINTENANCE	7
9.1	GENERAL	7
9.2	MAINTENANCE SCHEDULE.....	7
9.3	CLEANING ALARM	7
10.0	PROVISION OF SPARES	7
10.1	SOURCE OF SPARE PARTS.....	7
10.2	RECOMMENDED SPARE PARTS LISTS	7
11.0	IN-SERVICE SUPPORT.....	7
12.0	GUARANTEES/LIMITATION OF LIABILITY	7
13.0	APPENDICES	7

This product can not be modified without the written approval of Tronair, Inc. Any modifications done without written approval voids all warranties and releases Tronair, Inc., its suppliers, distributors, employees, or financial institutions from any liability from consequences that may occur. Only Tronair OEM replacement parts shall be used.

1.0 PRODUCT INFORMATION

1.1 DESCRIPTION

The device is intended to stabilize an aircraft by its fuselage during maintenance, whose maximum load does not exceed the rated capacity of the tailstand.

1.2 MODEL & SERIAL NUMBER

Reference nameplate on unit

1.3 MANUFACTURER

TRONAIR, Inc.
1 Air Cargo Pkwy East
Swanton, Ohio 43558 USA

Telephone: (419) 866-6301 or 800-426-6301
Fax: (419) 867-0634
E-mail: sales@tronair.com
Website: www.tronair.com

2.0 SAFETY INFORMATION

2.1 USAGE AND SAFETY INFORMATION

To ensure safe operations please read the following statements and understand their meaning. Also refer to your equipment manufacturer's manual for other important safety information. This manual contains safety precautions which are explained below. Please read carefully.



WARNING!

Warning is used to indicate the presence of a hazard that can cause **severe personal injury, death, and/or substantial property damage** if the Warning Notice is ignored.



CAUTION!

Caution is used to indicate the presence of a hazard, which will or can cause **minor personal injury or property damage** if the Caution Notice is ignored.

2.2 ALARM AND WARNING SYSTEMS

The tailstand has an alarm system that alerts the operator that a force of 100 to 150 pounds (45.36 to 68.04 kg) is being applied to the top of the cradle. The unit attached to the tailstand sounds a loud 85 db pulsating alarm until the force is reduced.

2.3 COMPONENT SAFETY FEATURES

Extension Pin provides a visual check that the pin is fully inserted

2.4 ENVIRONMENTAL SAFETY FEATURES

Tailstand is non-polluting.

2.5 CLOSED CIRCUITS

Reference **Figure 1**

2.6 NECESSARY PERSONAL PROTECTIVE EQUIPMENT

CAUTION!

Always wear safety glasses.

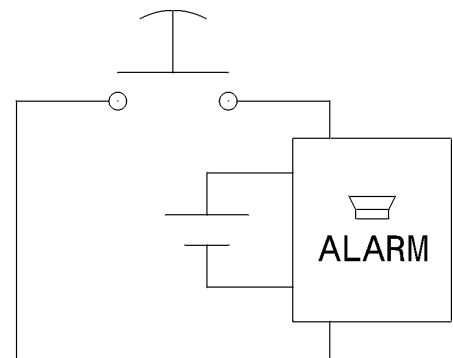

1 – Closed Circuits

2.7 SAFETY GUIDELINES

**CAUTION!**

1. **DO NOT** place hands on top of tailstand near base tube receiver while lowering tailstand extension. Pinch point exists between top of tube and bracket on extension.
2. **DO NOT** place feet under tailstand near base tube receiver while lowering tailstand extension. Pinch point exists between ground and extension tube.
3. **ALWAYS** install tailstand **AFTER** aircraft has been jacked to working position.
4. **Never** put hands between aircraft and tailstand cradle.
5. **ALWAYS** be sure tailstand extension pin is fully locked and inserted through the tube.
6. **NEVER** load tailstand by lowering jacks. **ALWAYS** lower and remove tailstand **BEFORE** lowering aircraft.
7. **DO NOT** place hands near the die springs on the load alarm while the stabilization stand is in use. Pinch point exists on the die springs and between the top plate and the base of the load alarm.
8. **DO NOT** allow prolonged exposure to the sounding alarm. The alarm sound may cause permanent hearing loss.
9. **DO NOT** place objects in the path of the alarm's horn opening that may limit the audible range and reduce the effectiveness of the alarm.
10. **DO NOT** turn setscrew located under the plunger switch. The distance between the setscrew and plunger is pre-set by the factory.

2.8 CONDITIONS FOR SAFE USE

- Use in a clean dry environment, on a hard level surface
- Operate between +4° C and 38° C/+40° F and 100° F

2.9 OPERATOR QUALIFICATIONS

This tailstand is intended to be used by a skilled and trained aircraft technician. The operator must be familiar with the jacking procedures for the aircraft to be raised, and the operation of the tailstand.

Installation/Maintenance/Dismantling Qualifications: This tailstand is to be installed, maintained, and dismantled by qualified technicians familiar with aircraft maintenance systems.

2.10 ADDITIONAL SAFETY MEASURES

This tailstand must be used in accordance with this Operation and Service Manual, and in accordance with the aircraft manufacturer's jacking and stabilizing procedures.

3.0 TRAINING

3.1 TRAINING REQUIREMENTS

The employer of the operator is responsible for providing a training program sufficient for the safe operation of the unit. This tailstand must be used in accordance with aircraft manufacturer's instructions.

3.2 TRAINING PROGRAM

The employer provided operator training program should cover safety procedures concerning use of the unit in and around the intended aircraft at the intended aircraft servicing location.

3.3 OPERATOR TRAINING

The operator training should provide the required training for safe operation of the unit.

NOTE: Maintenance and Trouble Shooting are to be performed by a skilled and trained technician.

4.0 ASSEMBLY**4.1 GENERAL INSTRUCTIONS**

1. This product should be assembled and/or repaired using good workmanship practices and proper tools. Bolts and elastic stopnuts should be tightened to a torque not to exceed industry standards for Grade 5 bolts.
2. All replacement parts must be the same as or better than the original parts supplied.
3. No modifications are allowed as they may adversely affect the tailstand's safety performance.

4.2 PRE-USE CHECKS

1. Refer to the Illustrated Parts List to identify and ensure that all parts are present.
2. Generally, check over unit and ensure the tightness of all nuts and bolts.

4.3 PERSONNEL REQUIREMENTS

This tailstand is to be assembled by qualified technicians familiar with aircraft maintenance systems.

4.4 ASSEMBLY STEPS

1. Slide alarm from holder and install a 9 volt battery in the alarm by removing two screws located in the back of the alarm. **Reference Figure 2.**
2. Fasten cradle assembly to extension tube with one (1) 3/8 - 24 x 2 3/4 inch hex head bolt, 3/8 inch flatwasher, and 3/8 - 24 elastic stopnut. **reference Figure 3.**

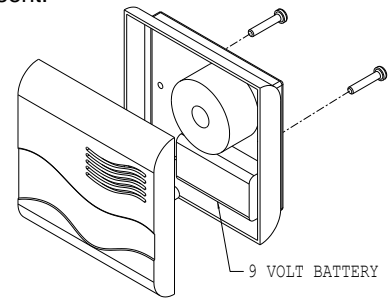
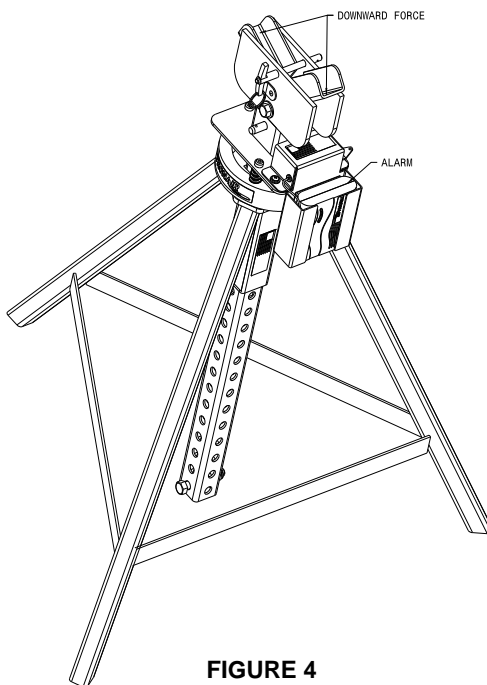
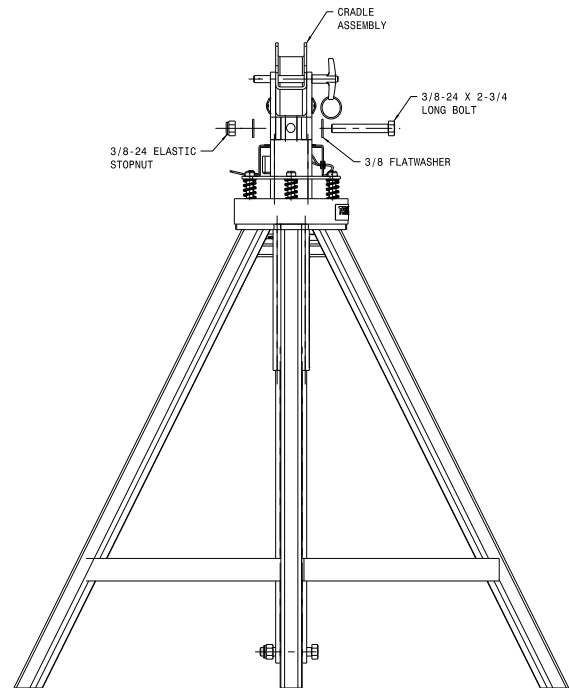
**FIGURE 2****FIGURE 4****FIGURE 3****4.5 INSPECTION AND TEST PROCEDURES**

1. It is recommended every 90 days to visually inspect all welds, cradle, extension pin, and extension pin holes in the base and extension tubing for defects. If defects are found, remove tailstand from active service until repairs are made.
2. Test alarm by slowly applying a force evenly distributed across the top of the cradle. The cradle head will lower and engage a limit switch. A loud pulsating alarm will then sound when the force reaches between 100 to 150 lbs (45.36 to 68.04 kg). If alarm does not sound, refer to the Troubleshooting section. **Reference Figure 4.**

5.0 OPERATION

5.1 NUMERICAL VALUES

- Minimum Closed Height 27 in (68.6 cm)
- Mechanical Extension 22 in (55.9 cm)
- Maximum Height Obtainable 49 in (124.5 cm)
- Weight 22 lbs (55.9 kg)
- Alarm (Battery Powered) 9 vdc
- Alarm Horn 85 db

5.2 OPERATING INSTRUCTIONS

The user should be familiar with the following statements prior to using the tailstand:



CAUTION!

1. **DO NOT** place hands on top of tailstand near base tube receiver while lowering tailstand extension. Pinch point exists between top of tube and bracket on extension.
2. **DO NOT** place feet under tailstand near base tube receiver while lowering tailstand extension. Pinch point exists between ground and extension tube.
3. **ALWAYS** install tailstand **AFTER** aircraft has been jacked to working position.
4. **Never** put hands between aircraft and tailstand cradle.
5. **ALWAYS** be sure tailstand extension pin is fully locked and inserted through the tube.
6. **NEVER** load tailstand by lowering jacks. **ALWAYS** lower and remove tailstand **BEFORE** lowering aircraft.
7. **DO NOT** place hands near the die springs on the load alarm while the stabilization stand is in use. Pinch point exists on the die springs and between the top plate and the base of the load alarm.
8. **DO NOT** allow prolonged exposure to the sounding alarm. The alarm sound may cause permanent hearing loss.
9. **DO NOT** place objects in the path of the alarm’s horn opening that may limit the audible range and reduce the effectiveness of the alarm.
10. **DO NOT** turn setscrew located under the plunger switch. The distance between the setscrew and plunger is pre-set by the factory.

5.2.1 Rules For Operating

- The user shall work in accordance with the Operation and Maintenance Manual
- The employer of the operator shall provide all necessary training
- Operate between +4° C and 38° C/+40° F and 100° F

5.2.2 Operation

When a force of 100 to 150 pounds (45.36 to 68.04 kg) is applied to the top of the cradle, the cradle head will lower and depress the plunger switch. This will activate the alarm which sounds a loud 85 db pulsating alarm until the force is reduced.

5.2.3 Alarm Test

Depress plunger switch and hold for a minimum of two (2) seconds. This will sound the alarm if the electronic circuitry, horn and battery are operating correctly. Refer to Trouble Shooting section of this manual if test fails.

5.2.4 Battery Test

Depress test button and hold for a minimum of two (2) seconds. This will sound the alarm if the battery is installed correctly.

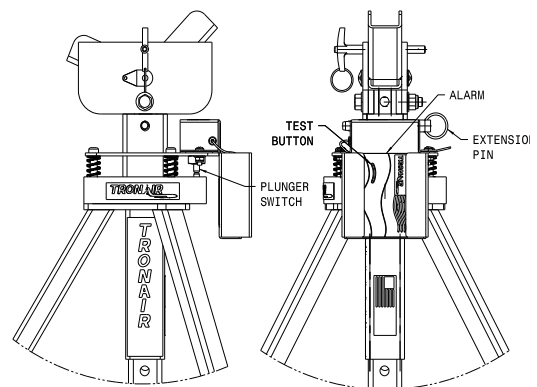

FIGURE 5



CAUTION!

Depressing the Test Button on the alarm does not provide a check for the entire electronic circuit!

5.2.5 Low Battery Warning

The alarm will “chirp” every 20 to 30 seconds to indicate the battery is low and needs changing.

5.2.6 Alarm Load Test

Place a force between 100 to 150 lbs (45.36 to 68.04 kg) to the top of the cradle. This will activate the alarm. Refer to Trouble Shooting section of this manual if test fails.

5.2.7 Tailstand Instructions

To Raise Aircraft:

- Jack aircraft to desired height
- Place tailstand on a hard, level surface
- Position tailstand at aircraft manufacturer's recommended location
- Raise tailstand extension cradle as close to aircraft as possible
- Install ball lock cradle pin through cradle and skid bar
- Install tailstand extension pin through inner telescoping tube
- Install tailstand extension pin through outer telescoping tube

WARNING!

The locking pin **MUST** be placed fully through the inner and outer extension tube.

The locking pin washer and ball lock **MUST** be placed outside the outer extension tube.

- Do not place extra locking pins in any other hole on the inner extension tube.
- Under no conditions should the locking pin's ball lock be inside the inner and outer extension tube.
- Never use a locking pin that has been damaged.
- Never use an inner and outer extension tube that has been damaged or deformed.
- Failure to comply could result in premature failure below certified weight and could cause serious injury including death.

- Make necessary adjustments to reduce force on tailstand when the alarm sounds.

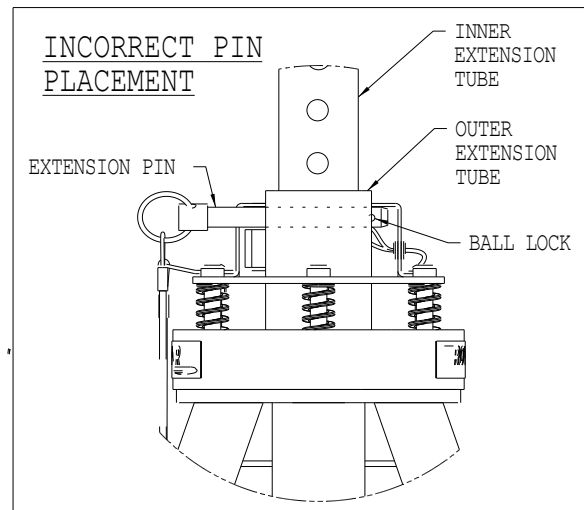
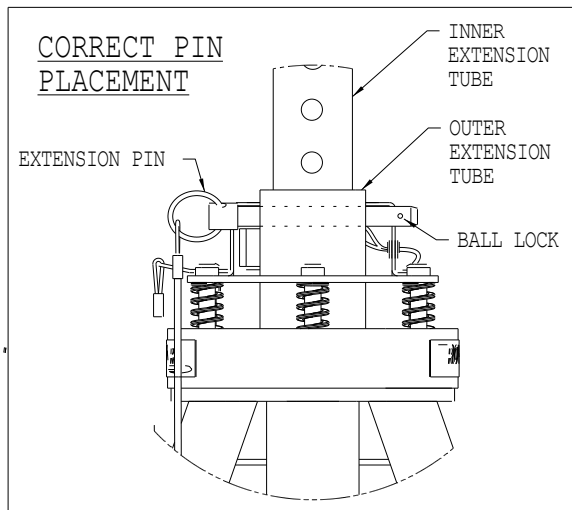
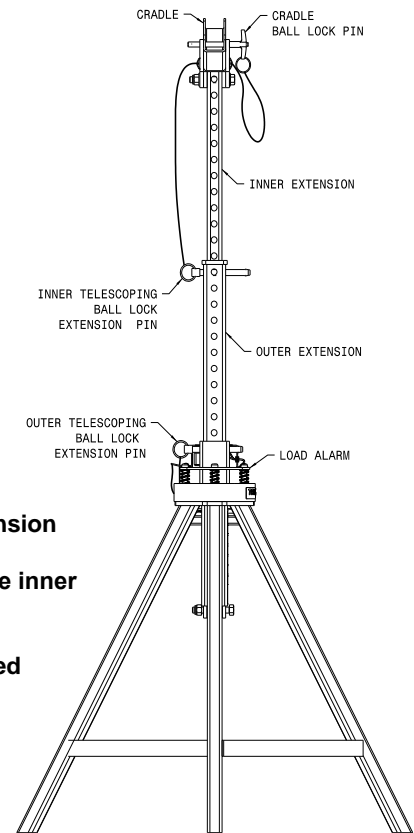
**To Lower Aircraft:**

- Clear all personnel from inside and under aircraft.
- Make necessary adjustments to reduce force on tailstand when the alarm sounds.
- Remove ball lock cradle pin and lower extension(s).
- Relocate tailstand away from aircraft and secure.
- Lower aircraft to the ground.

CAUTION!

- DO NOT** place hands on top of tailstand near base tube receiver while lowering tailstand extension. Pinch point exists between top of tube and bracket on extension.
- DO NOT** place feet under tailstand near base tube receiver while lowering tailstand extension. Pinch point exists between ground and extension tube.
- ALWAYS** wear safety glasses.



6.0 PACKAGING AND STORAGE

6.1 PACKAGING REQUIREMENTS

Tailstand is to be packaged as required to prevent damage to legs or cradle equipment during shipment.

6.2 HANDLING

Tailstand can be rolled by hand on its casters.

6.3 STRAPPING

Tailstand can be strapped down by suitable means to prevent unwanted movement during shipment.

6.4 PACKAGING PROTECTION

No special packaging material for cushioning or suspension is required.

6.5 LABELING OF PACKAGING

Packaging should be labeled **DO NOT DROP**.

6.6 STORAGE ENVIRONMENT

- Store tailstand between +4° C and +38° C/+40° F and 100° F
- Always store tailstand with extension all the way down
- Tailstand must be stored in a clean and dry environment

6.7 STORAGE SPACE AND HANDLING FACILITIES:

Weight 22 lbs (55.9 kg)
 Minimum Closed Height 27 in (68.6 cm)
 Mechanical Extension 22 in (55.9 cm)
 Maximum Height Obtainable 49 in (124.5 cm)

7.0 TRANSPORTATION

Lifting can be accomplished by crane and strap through top of tripod, or by fork truck under lower tripod support.
 Approximate weight = 66 lbs (30 kg).

8.0 TROUBLESHOOTING

TROUBLE	PROBABLE CAUSE	ACTION
Alarm Will Not Sound	Load was on the cradle for a short period of time	Limit switch has to be engaged for a minimum of two (2) seconds
	Defective Alarm	Replace Alarm
	Battery power depleted	Replace Battery
	Defective Limit Switch	Replace Limit Switch
	Broken wire connection	Check wire connection between limit switch and alarm
	Cradle head did not lower far enough to contact limit switch	Test per Section 5.5.2
Alarm “Chirps”	Indicates low battery	Replace battery (Alarm will “chirp” every 20 to 30 seconds for a minimum of 7 days until battery is changed)
Alarm Produces An Erratic Or Low Sound	Defective Alarm	Replace alarm

9.0 MAINTENANCE**9.1 GENERAL**

- All maintenance and/or repair work should be done using good workmanship practices and proper tools.
- Tailstand shall be maintained and repaired in accordance with the manufacturer's instructions. Such maintenance and repair shall be carried out by qualified persons.
- No modifications shall be carried out without prior written approval by Tronair.

9.2 MAINTENANCE SCHEDULE

Cleaning Annually or as Needed

NOTE: Wipe with soft cloth only, do not pressure wash or spray water directly at cradle.

9.3 CLEANING ALARM

Remove alarm from mounting bracket. The openings around the alarm perimeter may be cleared of debris by using compressed air or a vacuum cleaner hose to blow/suction openings. The outside surface of the alarm unit may be wiped with a damp cloth.

10.0 PROVISION OF SPARES**10.1 SOURCE OF SPARE PARTS**

Spare parts may be obtained from the manufacturer:

TRONAIR, Inc.	Telephone: (419) 866-6301 or 800-426-6301
1 Air Cargo Pkwy East	Fax: (419) 867-0634
Swanton, Ohio 43558 USA	E-mail: sales@tronair.com
	Website: www.tronair.com

For Spare Parts, Operations & Service Manuals or Service Needs:
Scan the QR code or visit Tronair.com/aftermarket

**10.2 RECOMMENDED SPARE PARTS LISTS**

Reference the following page(s) for Replacement Parts and Kits available.

11.0 IN-SERVICE SUPPORT

Contact Tronair, Inc. for technical services and information. See Section 1.3 – Manufacturer.

12.0 GUARANTEES/LIMITATION OF LIABILITY

Tronair products are warranted to be free of manufacturing or material defects for a period of one year after shipment to the original customer. This is solely limited to the repair or replacement of defective components. This warranty does not cover the following items:

- Parts required for normal maintenance
- Parts covered by a component manufacturers warranty
- Replacement parts have a 90-day warranty from date of shipment

If you have a problem that may require service, contact Tronair immediately. Do not attempt to repair or disassemble a product without first contacting Tronair, any action may affect warranty coverage. When you contact Tronair be prepared to provide the following information:

- Product Model Number
- Product Serial Number
- Description of the problem

If warranty coverage is approved, either replacement parts will be sent or the product will have to be returned to Tronair for repairs. If the product is to be returned, a Return Material Authorization (RMA) number will be issued for reference purposes on any shipping documents. Failure to obtain a RMA in advance of returning an item will result in a service fee. A decision on the extent of warranty coverage on returned products is reserved pending inspection at Tronair. Any shipments to Tronair must be shipped freight prepaid. Freight costs on shipments to customers will be paid by Tronair on any warranty claims only. Any unauthorized modification of the Tronair products or use of the Tronair products in violation of cautions and warnings in any manual (including updates) or safety bulletins published or delivered by Tronair will immediately void any warranty, express or implied.

The obligations of Tronair expressly stated herein are in lieu of all other warranties or conditions expressed or implied. **Any unauthorized modification of the Tronair products or use of the Tronair products in violations of cautions and warnings in any manual (including updates) or safety bulletins published or delivered by Tronair will immediately void any warranty, express or implied and Tronair disclaims any and all liability for injury (WITHOUT LIMITATION and including DEATH), loss or damage arising from or relating to such misuse.**

13.0 APPENDICES

APPENDIX I Declaration of Conformity

Parts List

When ordering replacement parts/kits, please specify model, serial number and color of your unit.

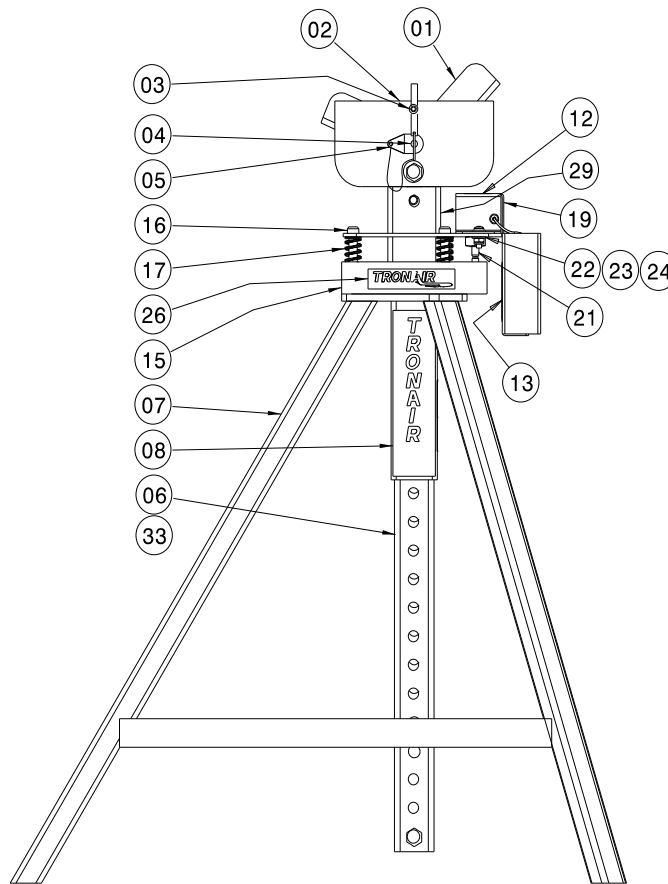

Item	Part Number	Description	Qty
1	H-1565-12*03.0	PAD, NEOPRENE 1/8" X 3"	6
2	Z-2789-01	WELDMENT, CRADLE	1
3	G-1310-0525	PIN, BALL-LOK	1
4	G-1351-04	RIVET, POP	2
5	H-1026*07.0	ASSEMBLY, LANYARD	1
6	Z-6262-01	WELDMENT, OUTER TELESCOPING TUBE	1
7	Z-6259-01	WELDMENT, TAILSTAND	1
8	V-1198-02	LABEL, TRONAIR	1
12	V-1001	LABEL, MADE IN USA	1
13	V-1779	LABEL, SERIAL NUMBER	1
15	TR-1883	BASE	1
16	G-1155-105210	SCREW, 5/16 X 1 SOC HD SHOULDER	3
17	H-2762	SPRING, LIGHT DUTY DIE	3
19	S-1923-01	COVER, LIMIT	1
21	G-1163-10	SCREW, HEX SOC CUP PINT SET ¼ - 20	1
22	G-1250-1030N	FLATWASHER, #10 NARROW	3
23	G-1159-103505	SCREW, ROUND HD CROSS REC #10 - 32 X 5/8 LG	2
24	G-1202-1035	ESN #10 - 32	2
26	V-1197-01	LABEL, TRONAIR	1
29	Z-5963-01	WELDMENT, OUTER TUBE	1
33	Z-6261-01	WELDMENT, INNER TELESCOPING TUBE	1

Parts List

When ordering replacement parts/kits, please specify model, serial number and color of your unit.

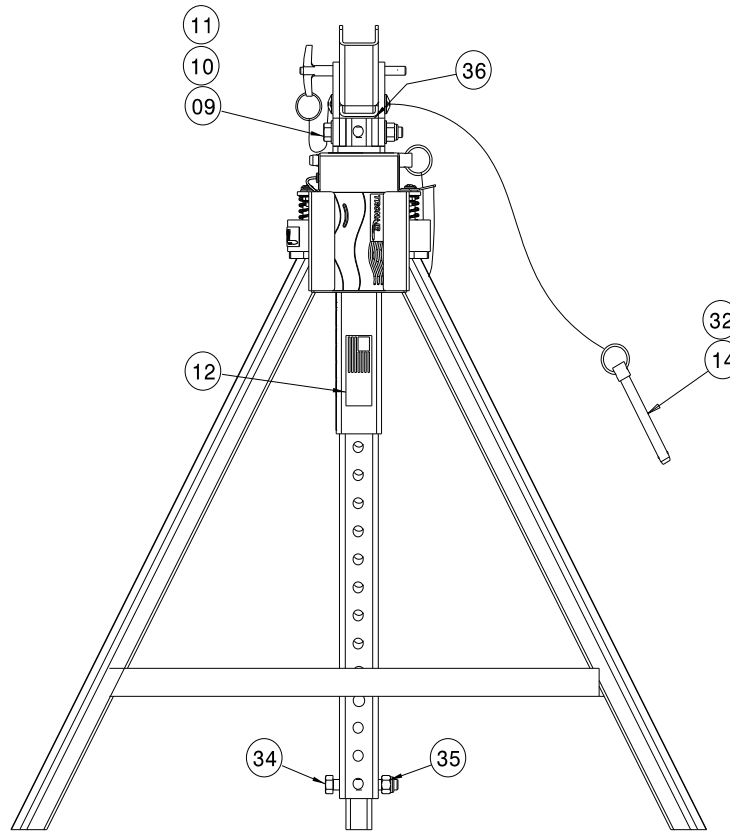

Item	Part Number	Description	Qty
9	G-1100-107526	BOLT, HH GR 5 3/8 – 24 X 2 3/4	1
10	G-1250-1070N	FLATWASHER, 3/8 NARROW	2
11	G-1202-1075	ESN, 3/8 – 24	1
12	V-1001	LABEL, MADE IN USA	1
14	G-1493	PIN 3/8 X 3 LG	1
32	H-1026*18.0	ASSEMBLY, LANYARD	1
34	G-1100-107022	BOLT, HH, 3/8 – 16 X 2	1
35	G-1202-1070	ESN, 3/8 – 16	1
36	J-3839	FLAT, SPACER	2

Parts List

When ordering replacement parts/kits, please specify model, serial number and color of your unit.

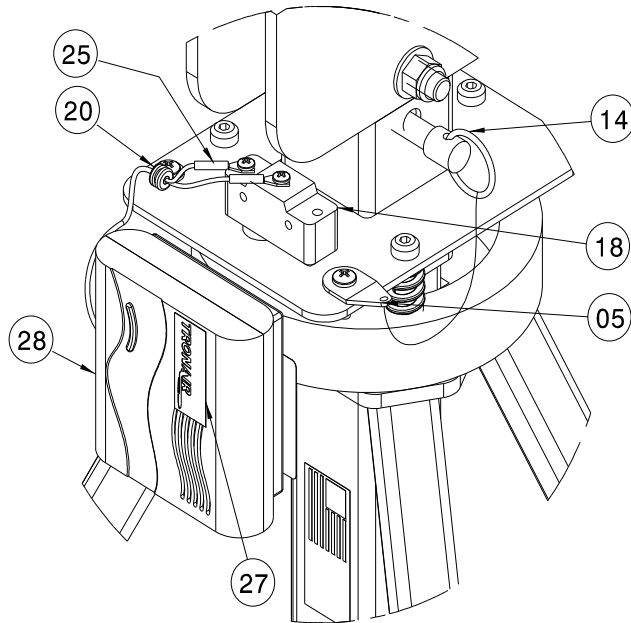

Item	Part Number	Description	Qty
5	H-1026*07.0	ASSEMBLY, LANYARD	1
14	G-1493	PIN 3/8 X 3 LG	1
18	EC-1796	SWITCH, LIMIT	1
20	H-1901-01	GROMMET	1
25	EC-1179-01	TERMINAL, FORKED TONGUE	2
27	V-1197-01	LABEL, TRONAIR	1
28	H-5136	ALARM	1
N/S	EC-1854	BATTERY, 9 VOLT	1



APPENDIX I

Declaration of Conformity



DECLARATION of CONFORMITY

The design, development and manufacture is in accordance with European Community guidelines

Tailstand with Alarm
03A5815C0010

Relevant provisions complied with by the machinery:
2006/42/EC

Relevant standards complied with by the machinery:
EN ISO 12100-1

Identification of person empowered to sign on behalf of the Manufacturer:

A handwritten signature in cursive script that reads "Patrick Finch". The signature is written in black ink and is positioned above a horizontal line.

Quality Assurance Representative