



OPERATION & SERVICE MANUAL



28.5 VDC Ground Power Unit

Models:

112850S0000	112850S0100	112850S0200	112850D0200
112850D0000	112850D0100	112850D0100AV	112850D0100-A5
112860S0000	112860S0100	112860S0200	112860S0200
	112860S0100-A4	112860S0100-A6	
112860D0000	112860D0100	112860D0200	
	112860D0100-A5	112860D0200-A5	



11/2021 - Rev. 04

REVISION	DATE	TEXT AFFECTED
01	01/2009	Original Release
02	03/2009	
03	06/2013	Modified 5.2.3 Converter Commissioning and 5.3 Switching On
04	11/2021	Modified parts list



	Models	112850S0000	112850S0100	112850S0200
	112850D0000	112850D0100/AV	112850D0100-A5	112850D0200
112860S0000	112860S0100	112860S0100-A4	112860S0100-A6	112860S0200
112860D0000	112860D0100	112860SD100-A5	112860D0200	112860SD200-A5

TABLE OF CONTENTS

PAGE

1.0	INTRODUCTION	1
1.1	MODEL DISCRIPTIONS	1
1.2	SAFETY NOTES	2
2.0	TECHNICAL DATA	3
3.0	SYSTEM DESCRIPTION	4
3.1	INTRODUCTION.....	4
3.2	DETAILED DESCRIPTION	4
3.3	PERFORMANCE UNDER UNUSUAL CONDITIONS	4
3.4	SYSTEM CONTROL.....	5
3.5	SAFETY AND PROTECTION	5
3.6	CONTROL AND MONITORING.....	5
3.6.1	Power Supplies for Controls & Monitoring.....	5
3.6.2	Internal System Control.....	5
3.6.3	Converter Operation.....	5
3.7	VOLTAGE REGULATION MODE	5
3.7.1	General	5
3.8	CONTROL PANEL.....	6
3.8.1	Operator Controls.....	6
3.8.2	Emergency Stop.....	6
3.9	OVERVIEW OF 28V DC GPU COMPONENTS	6
4.0	INSTALLATION AND CONNECTIONS	7
4.1	GOODS INSPECTION.....	7
4.2	HANDLING	7
4.3	PROTECTION.....	7
4.4	STORAGE	7
4.4.1	Floor Loading Capacity	7
4.4.2	Space Requirements/Dimensions	8
4.4.3	Altitude, Temperature & Humidity	8
4.5	ELECTRICAL CONNECTIONS (POWER).....	8
4.5.1	Cable Entry	8
4.5.2	Cable Sizing.....	9
4.5.3	Mains Fuses.....	9
4.5.4	Connections	9
5.0	OPERATING INSTRUCTIONS	10
5.1	GENERAL.....	10
5.1.1	Control Panel	10
5.1.2	Operator Controls.....	10
5.2	COMMISSIONING	10
5.2.1	Tools Needed.....	10
5.2.2	Settings	11
5.2.3	Converter Commissioning.....	11
5.3	SWITCHING ON.....	13
5.4	EMERGENCY STOP	13
5.5	OUTPUT VOLTAGE DC ADJUSTMENT	14
6.0	TROUBLE SHOOTING	14
6.1	GENERAL.....	14
6.2	PROCEDURES IN THE EVENT OF MALFUNCTIONS	15
6.3	MONITORS & FAULT INDICATION	16
7.0	MAINTENANCE AND SERVICE	16
7.1	PREVENTIVE MAINTENANCE	16
7.1.1	General	16
7.1.2	Cleanliness	16
7.1.3	Voltage Check.....	16
7.2	SERVICE	16
8.0	ADDITIONAL INFORMATION	17
8.1	LED FUNCTIONS & ARRANGEMENTS.....	17
9.0	GUARANTEES/LIMITATION OF LIABILITY	17
10.0	APPENDICES	17



112860S0000
112860D0000

Models
112850D0000
112860S0100
112860D0100

112850S0000
112850D0100/AV
112860S0100-A4
112860SD100-A5

28.5 VDC Ground Power Unit
112850S0100
112850D0100-A5
112860S0100-A6
112860D0200

112850S0200
112850D0200
112860S0200
112860SD200-A5

This product can not be modified without the written approval of Tronair, Inc. Any modifications done without written approval voids all warranties and releases Tronair, Inc., its suppliers, distributors, employees, or financial institutions from any liability from consequences that may occur. Only Tronair OEM replacement parts shall be used.

1.0 INTRODUCTION

Many systems and devices in the aerospace industry, and other fields, require a DC voltage of 28 volts. As this cannot be supplied by the utility directly, converters are employed which supply the necessary voltage and eliminate supply irregularities to a limited extent.

Normally these units are used to supply smaller aircraft with electric power. There are special reasons why aircraft need a 28V DC voltage for internal supply. To save costs in maintenance and operation, and also for environmental reasons, aircraft are supplied by external electrical power supplies when they are parked at airport terminal stands with their engines shut down.

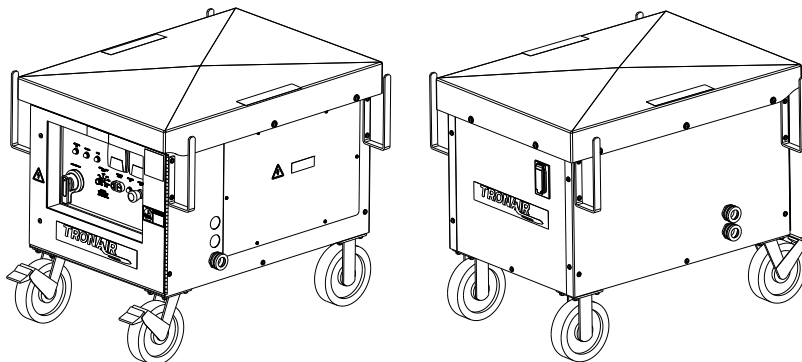

This manual describes the Tronair 28V Ground Power Unit (GPU). If you follow these instructions you will be able to handle the equipment with confidence and utilize all its facilities.

- NOTE**
1. Naturally an operating manual cannot cover every conceivable installation, operating, maintenance or servicing situation. Should problems arise, or if the data in this manual is not sufficiently detailed, please contact your local Tronair representative who will be pleased to give further assistance.
 2. If the equipment is installed for use as an aircraft ground power system, please pay particular attention to Section 10, which summarizes the special features of this type of application.

1.1 MODEL DISCTIPTIONS

Model Number	Output Cable	Input Frequency	Input Voltage	Input Cable ft (m)	Remarks
112850D0000	Dual	50(HZ)	200-415	NA	No input cable One 20ft 4/0(AWG) & one 50ft 2/0(AWG) non-engine starting DC output cable
112850D0100	Dual	50(HZ)	200-415	50 (15.2)	50ft input cable One 20ft 4/0(AWG) & one 50ft 2/0(AWG) non-engine starting DC output cable
112850D0100AV	Dual	50(HZ)	200-415	50 (15.2)	50ft input cable with external adjustable voltage One 20ft 4/0(AWG) & one 50ft 2/0(AWG) non-engine starting DC output cable
112850D0100-A5	Dual	50(HZ)	208-480	50 (15.2)	50ft input cable, two 50ft 4/0(AWG) DC output cables
112850D0200	Dual	50(HZ)	200-415	100 (30.5)	100ft input cable with one 20ft 4/0(AWG) One 50ft 2/0(AWG) non-engine starting DC output cable
112850S0000	Single	50(HZ)	200-415	NA	No input cable, one 20ft 4/0(AWG) DC output cable
112850S0100	Single	50(HZ)	200-415	50 (15.2)	50ft input cable, one 20ft 4/0(AWG) DC output cable
112850S0200	Single	50(HZ)	200-415	100 (30.5)	100ft input cable, one 20ft 4/0(AWG) DC output cable
112860D0000	Dual	60(HZ)	208-480	NA	No input cable One 20ft 4/0(AWG) & one 50ft 2/0(AWG) non-engine starting DC output cable
112860D0100	Dual	60(HZ)	208-480	50 (15.2)	50ft input cable One 20ft 4/0(AWG) & one 50ft 2/0(AWG) non-engine starting DC output cable
112860D0100-A5	Dual	60(HZ)	208-480	50 (15.2)	50ft input cable, two 50ft 4/0(AWG) DC output cables
112860D0200	Dual	60(HZ)	208-480	100 (30.5)	100ft input cable One 20ft 4/0(AWG) & one 50ft 2/0(AWG) non-engine starting DC output cable
112860D0200-A5	Dual	60(HZ)	208-480	100 (30.5)	100ft input cable Two 50ft 4/0(AWG) DC output cables
112860S0000	Single	60(HZ)	208-480	NA	No input cable, one 20ft 4/0(AWG) DC output cable
112860S0100	Single	60(HZ)	208-480	50 (15.2)	50ft input cable, one 20ft 4/0(AWG) DC output cable
112860S0100-A4	Single	60(HZ)	208-480	50 (15.2)	50ft input cable with Crouse-Hinds plug installed One 20ft 4/0(AWG) DC output cable
112860S0100-A6	Single	60(HZ)	208-480	50 (15.2)	50ft input cable, one 20ft 4/0(AWG) DC output cable, AP20468 plug
112860S0200	Single	60(HZ)	208-480	100 (30.5)	100ft input cable, one 20ft 4/0(AWG) DC output cable
112860S0200SP	Single	60(HZ)	208-480	100 (30.5)	100ft input cable, one 20ft 4/0(AWG) DC output cable, special paint color



		28.5 VDC Ground Power Unit		
	Models	112850S0000	112850S0100	112850S0200
	112850D0000	112850D0100/AV	112850D0100-A5	112850D0200
112860S0000	112860S0100	112860S0100-A4	112860S0100-A6	112860S0200
112860D0000	112860D0100	112860SD100-A5	112860D0200	112860SD200-A5

1.2 SAFETY NOTES

The 28V DC GPU is a piece of electrical equipment which carries voltages and currents that are hazardous to personnel. The following advice must therefore be observed at all times:

- Installation, operation and maintenance of this equipment must be carried out according to the instructions in this manual.
- Ensure that the equipment is handled only by well-trained and authorized personnel.
- Take suitable measures to ensure that only trained operating and maintenance personnel have access to the interior of the system; the doors should be kept locked and the keys retained by authorized persons.
- System installation, service and maintenance must be performed by trained staff.
- The relevant regulations of the local codes and standards, and other safety instructions should be observed.
- All personnel who have to work on the equipment should be familiar with first-aid procedures relating to electrical accidents.
- Even when the equipment is switched off, a few internal parts remain “live” while they are connected to the incoming supply.
- Work on the equipment must only take place with the unit switched off and isolated. Proper Lockout/Tagout procedures must be followed at all times.
- Built-in capacitors can remain charged, even when the complete system is “de-energized”. They should be suitably discharged by trained personnel before contact is made with the connections.
- Fuses must not be rewired or shorted out and rewired fuses must not be used. When replacing fuses, only the same or lower current ratings and the same types (slow-blow, quick-acting, very quick-acting) should be used.
- The system environment should be kept as clean as possible and metallic or other electrically-conducting dust particles in particular must be prevented from being sucked in through the air inlet.
- The warning and hazard notices inside the equipment must be observed.

Explanation of the warning symbols used in these operating instructions are as follows:



WARNING Appears alongside all instructions which must be followed exactly in order to eliminate personal injury and corruption/destruction of data

IMPORTANT Appears alongside all instructions which must be followed in order to eliminate damage to equipment and/or malfunctions

NOTE Indicates important information or advice, which must be followed during installation, operation, service or maintenance.



		28.5 VDC Ground Power Unit		
	Models	112850S0000	112850S0100	112850S0200
	112850D0000	112850D0100/AV	112850D0100-A5	112850D0200
112860S0000	112860S0100	112860S0100-A4	112860S0100-A6	112860S0200
112860D0000	112860D0100	112860SD100-A5	112860D0200	112860SD200-A5

2.0 TECHNICAL DATA

Length: 42 in (107 cm)
Width 31 in (79 cm) Single
 33 in (84 cm) Dual
Height 33 in (84 cm)

28V DC GPU 600A	
Input Data	
Input power	25 kVA
Nominal voltage 3ph	208V/60 Hz, 400V/50 Hz, 480V/60Hz ±10%
Nominal frequency	50 Hz or 60 Hz ±5%
Nominal input current at	
208V 60Hz	56 A
400V 50Hz	29 A
480V 60Hz	24 A
575V 60Hz	21A
Output Data	
Output power	16.8 kW
Nominal voltage	28V
Nominal current	600 A
Voltage adjustment range	Nominal 20 – 31V (other values on request)
DC ripple voltage (without filter)	< 1V
DC ripple voltage (with filter)	< 786 mv
Voltage characteristics:	
– static	±1%
– dynamic (100% load step)	MIL-Std. 704, Fig. 5
Recovery time	< 200 ms
Output frequency	DC
Overload capability	Max 2000A for up to 2sec
Option	
General Data	
Total efficiency	> 90%
Maximum losses	4 kW
Audible noise	< 70 dB(A)
Temperature range	-4 – +104° F (-20 - +40°C)
Humidity	max. 95%
Paint finish	RAL 7032
Protection type	IP54/Nema 3R

		28.5 VDC Ground Power Unit		
	Models	112850S0000	112850S0100	112850S0200
	112850D0000	112850D0100/AV	112850D0100-A5	112850D0200
112860S0000	112860S0100	112860S0100-A4	112860S0100-A6	112860S0200
112860D0000	112860D0100	112860SD100-A5	112860D0200	112860SD200-A5

3.0 SYSTEM DESCRIPTION

3.1 INTRODUCTION

The 28V GPU is manufactured using the latest state-of-the-art technology. The design concept and the selected components utilize the latest trends in power electronics, and represents the best solution for the different problems of Ground Power Supplies. The 28V GPU is built with output voltage regulation and load current limiting. The following block diagram shows the principle.



WARNING!

Even when the 28V GPU is switched off, a few internal parts still remain “live”.

The transformer converts the mains supply to a voltage suitable for supplying the load via the rectifier. The transformer is a two winding transformer which provides galvanic isolation between the mains and the load. The rectification is achieved by using a 6-pulse SCR. The output filter network limits the ripple at the output voltage to a low level.

An integrated control panel with push buttons and an LED's operate the unit is located on the front door of the unit.

3.2 DETAILED DESCRIPTION

An integrated interface board contains a micro controller to control and monitor all functions of the system. Depending on the measurement values, the input voltage of the transformer is regulated in order to obtain the correct output voltage. All functions are digitally controlled.

The following functions are built in:

- Measurement and evaluation
- Output voltage regulation and current limiting
- System control (PLC function)

Measurement values from the input are collected via the interface board, and from the output direct to the controller board, where they are evaluated and monitored.

Normally the overload and short circuit protection is provided by the interface board. Protection, by the input circuit breaker CB1, takes place in case of malfunctions of the electronics.

The measurement values are also used for **voltage regulation**. The output voltage regulation consists of a voltage regulator plus a current regulator, which is the main regulator. This means if a current limit has been set in the setup menu, this current regulator will limit the output voltage to a value at which the set current is reached. If the current is less than the set maximum, the voltage regulator will limit the output voltage to obtain the set value. In this case, the current regulator is turned off. The output of these regulators is converted to a pulse pattern, which is transmitted to the firing board to fire the SCR modules.

The complete unit is operated via the **system control**. This works similar to a standard PLC. This means that particular input events will generate particular output events.

There is a Control Panel on the front of the cabinet which contains the main disconnect switch with LED (light emitting diodes) indications and on/off buttons. The Control Panel gives the user a comprehensive status indication of the unit. The LED's on the control panel show the status of each logical section of the unit, displaying green, yellow or red, and flashing or steady state to show various normal, available, warning and abnormal states of the unit. The push buttons allow the user to switch the DC output on and off and adjust unit settings. Output voltage and current are displayed on the control panel.

3.3 PERFORMANCE UNDER UNUSUAL CONDITIONS

Overload - The converter can deliver up to a maximum of 2000 A for 3 sec. At higher overloads the output current is limited.

Short-circuit on the load busbar - In principle, a short-circuit occurring on the output side is handled similar to an overload, except that the output voltage is very low. The output power will be limited as described above for an overload. The rectifier itself has short-circuit protection.

Mains fault - If the mains supply is outside permissible tolerances, it is not possible to start the system. If the converter is running and the mains supply goes out of the permissible tolerances, the converter will switch off within 50ms.

Output fault - The converter monitors the output voltage continuously. If it exceeds the permissible tolerances the unit is switched off.

Over-temperature - In the event of a fan failure, the system continues to run normally until the over-temperature protection cuts in.



		28.5 VDC Ground Power Unit		
	Models	112850S0000	112850S0100	112850S0200
	112850D0000	112850D0100/AV	112850D0100-A5	112850D0200
112860S0000	112860S0100	112860S0100-A4	112860S0100-A6	112860S0200
112860D0000	112860D0100	112860SD100-A5	112860D0200	112860SD200-A5

3.4 SYSTEM CONTROL

System control consists of one System Interface Board, a firing board, one Operator Panel.

The System Interface Board handles the master system control function. Control commands from the Control Panel CP are transmitted to this controller, evaluated and converted into the appropriate actions. Current operating parameters (measured values etc.) are also evaluated by the System Interface Board. The following measure values are not displayed, but are also monitored for deviations from the specification:

- Input under & over-voltage
- Output under & over-voltage
- Output overload
- Over-temperature

3.5 SAFETY AND PROTECTION

The design philosophy for the 28V DC GPU is that it will endeavor to protect itself at all times. Self-protection is incorporated in both the hardware and software designs. Where situations arise that could either cause damage to the converter, or endanger the output load, the general rule is to disconnect and/or shutdown.

For safety of personnel, an Emergency Stop button is fitted local to the Control Panel on the front of the converter cubicle.

3.6 CONTROL AND MONITORING

3.6.1 Power Supplies for Controls & Monitoring

All the electronic cards within the converter receive their power via transformers.

3.6.2 Internal System Control

System Interface Board has the function of complete system control.

Control Panel consists of control and display elements for the user. Commands are analyzed by the system controller and interpreted into actions. Measurement values for the input and output circuits are processed and displayed.

3.6.3 Converter Operation

As soon as mains incoming power is applied to the control logic the microprocessors commence operating and the internal function becomes active. Initially their only function is a 'watchdog operation' checking for faults within the converter and monitoring the incoming supply for voltage and frequency deviations. Any faults or deviations detected are reported internally at the System Interface Board.

3.7 VOLTAGE REGULATION MODE

3.7.1 General

The unit supplies a load which requires a supply voltage with very little deviation. (Normally 28V DC +/- 1%). If a very long cable is used between the converter and the aircraft (load), a voltage drop will be created which might be greater than the acceptable voltage tolerance of the aircraft. If this happens, it is no longer possible for many units on the market to provide an acceptable voltage supply to the aircraft especially under all load conditions.

To overcome this problem, two possibilities are available:

1. The cable between the converter and the load could be designed in such a way that the voltage drop will be decreased so that the supply voltage is within tolerance range. The amount of copper wires and/or size can be increased or parallel cables can be used. However there comes a point where the size of the copper wires required could become too heavy or costly, or if the length of run is so long, that increasing the amount or wire size will still not be enough to keep the tolerance within the voltage range, for all load conditions.
2. The converter must incorporate a LDC (Line Drop Compensation) system that can provide active compensation so as to automatically compensate for the voltage drop.

With very long cable runs, parallel cables will increase the wire investment costs dramatically and if flexible aircraft cables are also used, then parallel cabling might not be possible or practical.

To ensure that the proper voltage is delivered to the aircraft plug under all load conditions, there must be a means of measuring the voltage at the aircraft plug, and sending those voltage signals back to the converter, so they can be analyzed and responded to. This requires that signal wires be run between the plug and the converter unit, where again cost and practicality must be considered.



			28.5 VDC Ground Power Unit	
	Models	112850S0000	112850S0100	112850S0200
	112850D0000	112850D0100/AV	112850D0100-A5	112850D0200
112860S0000	112860S0100	112860S0100-A4	112860S0100-A6	112860S0200
112860D0000	112860D0100	112860SD100-A5	112860D0200	112860SD200-A5

3.8 CONTROL PANEL

There is a local Control Panel on the cubicle door of the converter which contains a light emitting diode (LED) indications, E-Stop, and meters

The LED's on the control panel are red, green and yellow. They are also bi-functional, able to display as steady state or flashing. With combinations it is possible to display healthy state, non-operational, abnormal and fault conditions.

- Green steady state Running or switched on
- Yellow flashing Warning
- Red flashing Hardware fault (circuit breaker, contactor, etc.)
- Red steady state Abnormal condition (e.g. mains fault, overload, etc)

The Red indicating LED is for fault conditions that are recoverable, such as overload. These faults are displayed as a Steady Red light. Faults requiring maintenance attention, such as CB open, are displayed as a Flashing Red light.

3.8.1 Operator Controls

Push buttons “ON” and “OFF” control the converter operations.

3.8.2 Emergency Stop

In an emergency, to immediately open the unit's input and output contactors, the large red button on the Control Panel must be pressed.

IMPORTANT Bear in mind, however, that the mains in feed is still “live”. The converter can only be isolated by using suitable external means such as padlocking the supply breakers of the incoming distribution board.

3.9 OVERVIEW OF 28V DC GPU COMPONENTS

The modules and components of the individual sizes of the 28V DC GPU are shown in the outline drawings in this section. The sizes and arrangement of the modules and components shown vary slightly according to the power rating and version of the 28V DC GPU sets.

Abbreviation	Description of Component
MOD 1	Rectifier SCR
PCB 2	Firing board
	Interface board
K-1	28V Relay
K-2	28V Relay
T2	Power supply transformer
T2	Power supply transformer
T3	Power supply transformer
PAN 1	Control panel
CAPS	Filtering capacitors
FAN 1	Cooling Fan
R 1	Load resistor
CB 1	Input circuit breaker
CB 2-6	Protective circuit-breaker control voltage
SW 5	Current limit POT
T 1	Isolated 3 phase input transformer
AUX 1	Transformer auxiliary voltage
AUX 2	Transformer auxiliary voltage
CONT 1	DC output contactor
CONT 2	DC output contactor



		28.5 VDC Ground Power Unit		
	Models	112850S0000	112850S0100	112850S0200
	112850D0000	112850D0100/AV	112850D0100-A5	112850D0200
112860S0000	112860S0100	112860S0100-A4	112860S0100-A6	112860S0200
112860D0000	112860D0100	112860SD100-A5	112860D0200	112860SD200-A5

4.0 INSTALLATION AND CONNECTIONS

4.1 GOODS INSPECTION

Before leaving the factory, the correct mechanical and electrical state of the 28V DC GPU is checked in a final inspection. As soon as the equipment has arrived check whether any freight damage has occurred and if necessary, bring this to the attention of the freight operator. **In no circumstances put a damaged converter into service** without consulting your Tronair representative first.

4.2 HANDLING

The converter can be rolled into place or moved by means of a forklift or pallet lift truck

IMPORTANT Moving by crane should only be used in exceptional circumstances using load-spreading rails above the unit.

Please pay attention to the following handling advice:

- Equipment should only be transported in an upright position
- The equipment must not be tilted or turned over
- Always avoid sharp impacts
- Where possible, leave the equipment in its original packing when moving it, this provides the best possible protection against damage
- When moving the equipment on raised floors, it could be necessary to use a means of load distribution in order to avoid damage to the floor

4.3 PROTECTION

During installation and cabling it is absolutely essential that the equipment is protected from the ingress of water, concrete or metal particles, and dust etc. Protection of the equipment is particularly important when other trades or construction is taking place in the same vicinity. All inlets and parts of the equipment not being worked on should be covered, at the least with heavy-duty polyethylene, and preferably with more substantial packing.

It is also important to ensure that people working overhead do not stand on the equipment or use it as a convenient platform for other work.

On completion of any work requiring the opening of the equipment doors or panels or removal of cover plates or gland plates, the unit should be thoroughly vacuumed out and re-packed or protected. Tronair accepts no liability for any damage to equipment caused by physical mal-treatment or by ingress of foreign material.

4.4 STORAGE

If it is necessary to store the converter for any length of time than it should be stored in a dry, well-ventilated room that is free of corrosive materials. Where possible, the original packing should not be removed during storage.

IMPORTANT In no circumstances must the converter be stacked, or stored outside.

4.4.1 Floor Loading Capacity

The weight of the equipment is distributed over a relatively small area; special care must therefore be taken to ensure that the floor loading capacity is adequate. The exact value can be obtained from the Technical Data. If necessary, the supporting surface can be reinforced by interposing a suitable steel plate. Please consult your architect or Tronair representative if you require assistance.

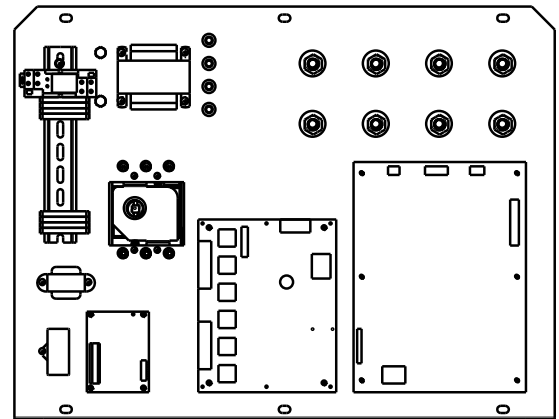



		28.5 VDC Ground Power Unit		
	Models	112850S0000	112850S0100	112850S0200
	112850D0000	112850D0100/AV	112850D0100-A5	112850D0200
112860S0000	112860S0100	112860S0100-A4	112860S0100-A6	112860S0200
112860D0000	112860D0100	112860SD100-A5	112860D0200	112860SD200-A5

4.4.2 Space Requirements/Dimensions

About 80 cm/32" clearance should be left in front of the unit to provide unimpeded access to the cubicle. Local or general safety regulations, e.g. escape routes, should also be observed. In no circumstances must the air inlet (around the bottom of the unit) and the air outlet (around the top of the unit) be covered or obstructed.

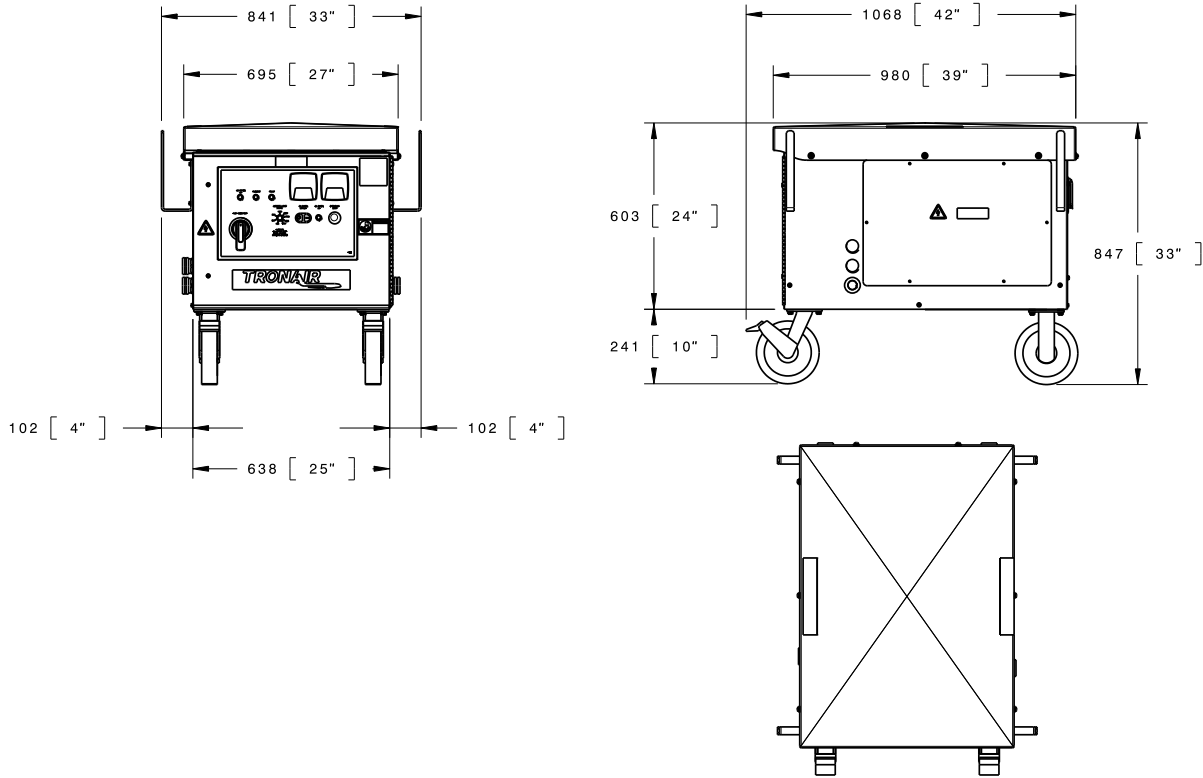

4.4.3 Altitude, Temperature & Humidity

The 28V DC GPU is designed for an installation altitude of up to 1000 meters above mean sea level, an ambient temperature of -20 to 40 °C / -4 to +104 °F and a relative humidity of up to 95%. The optimum temperature is around 68 °F. Please ensure that any existing air-conditioning plant meets these conditions and is also able to remove the unit's dissipated heat. Details are shown in the Technical Data (Section 2). The cooling air must always be free of corrosive agents. You should consult your Tronair representative if planning an installation above 1000 meters.

4.5 ELECTRICAL CONNECTIONS (POWER)

4.5.1 Cable Entry

The input and output cables are connected in the lower part of the cubicle. The cables can be brought up to the cubicle from the rear (input cable) and the right (output cable) and led in through end panel of the cubicle. Please refer to table below for the cable sizes, which must conform to local electrical code.

Cables must be properly gasketed with a screwed gasket fitted with a strain-relief device and sealing ring.



			28.5 VDC Ground Power Unit	
	Models	112850S0000	112850S0100	112850S0200
	112850D0000	112850D0100/AV	112850D0100-A5	112850D0200
112860S0000	112860S0100	112860S0100-A4	112860S0100-A6	112860S0200
112860D0000	112860D0100	112860SD100-A5	112860D0200	112860SD200-A5

4.5.2 Cable Sizing

Cables should be sized in accordance with the **rating of the next protective device upstream**, taking into account temperature, voltage-drop and installation method factors, as per the appropriate standard for the site. In general, Tronair recommends that the voltage-drop for both input and output power cables should not exceed 1.5%, and that the connecting cables should be as short as possible especially the output cable (less than 10 m/30 feet is recommended). Tronair should be consulted if these requirements cannot be met.

When specifying the cable lengths allow for about 0.5 m/20 in. inside the cubicle. The table on the following page shows the recommended cable types:

Equipment Type	Line Voltage	Rated Amps	Input Cable (If Less Than 30')/ Copper Size	Output Cable
28V DC GPU 600A	208	56	1 x NYY 4 x 10 RE/10 or #4	2 x NYY 120 or 2x 4/0 cables
	230	51	1 x NYY 4 x 10 RE/10 or #4	
	400	29	1 x NYY 4 x 6 RE/6 or #8	
	480	24	1 x NYY 4 x 4 RE/4 or #8	
	575	20	1 x NYY 4 x 4 RE/4 or #8	

4.5.3 Mains Fuses

To meet Health & Safety requirements, lockable isolating fused-switches must always be installed for the mains infeed. The fuses should be of type GL. Likewise, it should be possible to isolate the converter output from downstream circuits by means of an external lockable switch or circuit breaker. Please consult your Tronair representative regarding use of circuit breakers for the mains infeed.

Equipment Type	Mains Isolator	CB
28V DC GPU 600A	100 A	25 A, 5A

4.5.4 Connections

Power:

- 3 phase Mains Supply + Neutral
- 2 wire 28V DC + and -

The terminal arrangement will depend on the size and configuration of the 28 VDC GPU. The following drawings show the various configurations:

Terminal	No. of Terminal	Function	Short Name
	L1	Mains Input	L1
	L2	Mains Input	L2
	L3	Mains Input	L3
	N50/N60	Mains Neutral	N50
	+	Load Output +	
		Load Output -	



		28.5 VDC Ground Power Unit		
	Models	112850S0000	112850S0100	112850S0200
	112850D0000	112850D0100/AV	112850D0100-A5	112850D0200
112860S0000	112860S0100	112860S0100-A4	112860S0100-A6	112860S0200
112860D0000	112860D0100	112860SD100-A5	112860D0200	112860SD200-A5

5.0 OPERATING INSTRUCTIONS

5.1 GENERAL

This chapter describes how the 28V DC GPU should be operated. After an introduction to the operator controls and indicators, the steps for switching the system on and off are given. A smooth sequence of operations is only achieved if the individual steps are carried out in the specific order.

5.1.1 Control Panel

The Control Panel on the cubicle door contains LED indicators, push buttons, main disconnect switch and E-stop switch.

Specific switching functions are initiated, operating information are displayed.

If an abnormal operating condition or fault occurs, the red “General failure” LED lights up. At the same time the LED’s on the control panel show the current operating status and the fault is indicated on the panel.

5.1.2 Operator Controls

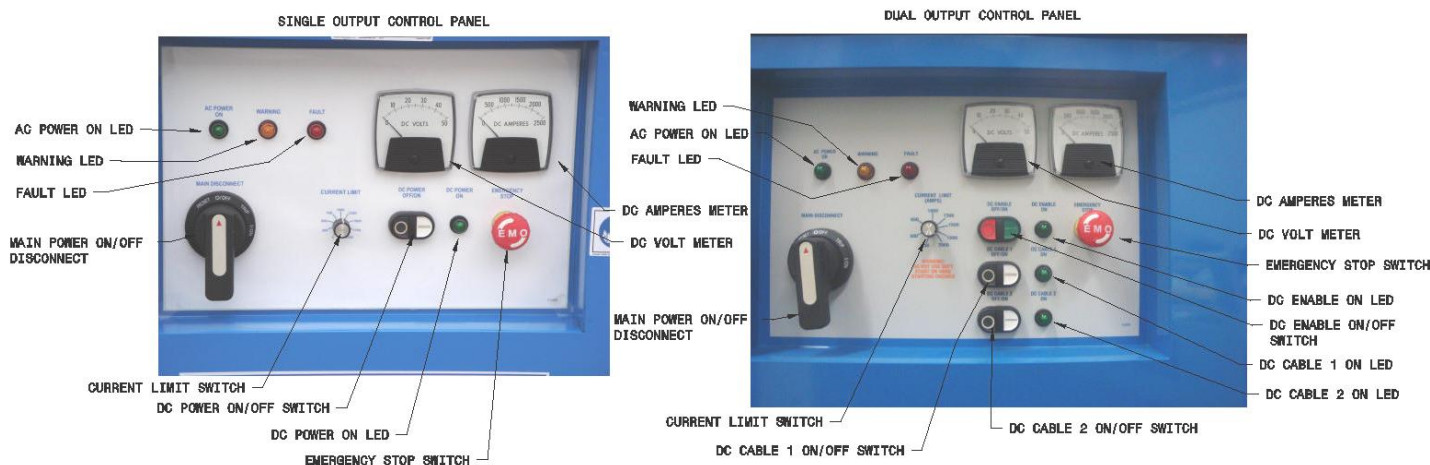

5.2 COMMISSIONING

WARNING!



Before initial start-up, check the following:

1. Is the equipment damaged? If yes, do not put into service without consulting your Tronair representative
2. Is the cabling properly installed? (Mains, output, remote control, etc.,?) Correct if necessary

5.2.1 Tools Needed

The following tools will be needed in order to put the 28 VDC GPU into operation:

- Multimeter
- Allen wrench
- 7/16 wrench
- Various screwdrivers



		28.5 VDC Ground Power Unit		
	Models	112850S0000	112850S0100	112850S0200
	112850D0000	112850D0100/AV	112850D0100-A5	112850D0200
112860S0000	112860S0100	112860S0100-A4	112860S0100-A6	112860S0200
112860D0000	112860D0100	112860SD100-A5	112860D0200	112860SD200-A5

5.2.2 Settings

The rectifier is available in 50 Hz and 60 Hz, both units are capable of being operated at various input voltages. The 50 Hz unit can be operated with 200V, 380V or 415V and the 60Hz unit with 208V, 240V or 480V. Before the mains supply is switched on, the unit type has to be adjusted correctly.

Setting the various transformer taps:

The unit is equipped with two control voltage transformers (T2 and T3) and one main transformer (T1). The wires have to be connected to the correct tap in accordance with the mains input voltage at T1 transformer. T1 transformer has terminals for 3 different input voltages. Place the wire jumpers according to the drawings below.

VOLTAGE CHANGING INSTRUCTIONS – 50 Hz

kVA	26.5	High Voltage: 415/380/200		Low Voltage: 30Y/ 17							
Phase	3										
Hz	50										
%IZ	4.6	RECONNECT H1,H2, H3 INPUT TAPS AS REQUIRED									
Rise	150 °C										
Ins. Class	220 °C	High Voltage: Lines on H1, H2, H3		<table border="1"> <tr> <td>Volts</td> <td>415</td> <td>380</td> <td>200</td> </tr> </table>		Volts	415	380	200		
Volts	415	380	200								
Weight	250 lbs	Low Voltage:		<table border="1"> <tr> <td>Line - Line</td> <td>Line - Neutral</td> <td>A1-A2</td> </tr> <tr> <td>30 V 25 kVA</td> <td>17 V</td> <td>120 V 1.5 kVA</td> </tr> </table>		Line - Line	Line - Neutral	A1-A2	30 V 25 kVA	17 V	120 V 1.5 kVA
Line - Line	Line - Neutral	A1-A2									
30 V 25 kVA	17 V	120 V 1.5 kVA									
Class	AA										
Wire	Al										

VOLTAGE CHANGING INSTRUCTIONS – 60 Hz

kVA	26.5	High Voltage: 480/240/208		Low Voltage: 30Y/ 17							
Phase	3										
Hz	60										
%IZ	4.6	RECONNECT H1,H2, H3 INPUT TAPS AS REQUIRED									
Rise	150 °C										
Ins. Class	220 °C	High Voltage: Lines on H1, H2, H3		<table border="1"> <tr> <td>Volts</td> <td>480</td> <td>240</td> <td>208</td> </tr> </table>		Volts	480	240	208		
Volts	480	240	208								
Weight	250 lbs	Low Voltage:		<table border="1"> <tr> <td>Line - Line</td> <td>Line - Neutral</td> <td>A1-A2</td> </tr> <tr> <td>30 V 25 kVA</td> <td>17 V</td> <td>120 V 1.5 kVA</td> </tr> </table>		Line - Line	Line - Neutral	A1-A2	30 V 25 kVA	17 V	120 V 1.5 kVA
Line - Line	Line - Neutral	A1-A2									
30 V 25 kVA	17 V	120 V 1.5 kVA									
Class	AA										
Wire	Al										

5.2.3 Converter Commissioning

WARNING!



- A. Commissioning must be only carried out by trained personnel since work has to be done on component that may be “live”!
- B. Power up the device only when requested to do so in the following text.

ATTENTION:

- I. Commissioning tasks should be carried out if:
 - the system is being put into service for the first time,
 - changes have been made, or
 - repairs were carried out



		28.5 VDC Ground Power Unit		
	Models	112850S0000	112850S0100	112850S0200
	112850D0000	112850D0100/AV	112850D0100-A5	112850D0200
112860S0000	112860S0100	112860S0100-A4	112860S0100-A6	112860S0200
112860D0000	112860D0100	112860SD100-A5	112860D0200	112860SD200-A5

5.2.3 Converter Commissioning (continued)

II. Carry out the individual steps in the correct sequence:

1. Check all T-1 transformer connections and tighten if necessary. Ensure voltage is tapped for **(480, 240, 208VAC 60Hz or 415,380, 200 VAC 50Hz)**
2. Ensure **MAIN DISCONNECT SWITCH** on the **GPU** is in the **OFF** position
3. Connect AC input power cable to the main power outlet and apply electrical power
4. Set current limiting switch on front panel to highest setting (**2000 AMP**)
5. Turn **GPU** main disconnect switch to **ON**
6. Ensure green main input power lamp is **ON**, DC voltmeter is indicating 28.5 volts, and no other fault lamps are on

NOTE: Ensure DC output power is not on and DC lamps are off.

7. For all models, connect a load bank to the **DC OUTPUT CABLE 1**, set load bank to **2000 Amps**, and ensure load bank switch is **OFF**
8. Connect a digital multi meter to the test points on the load bank

NOTE: The following test is for Single Output Cable units.

9. Push the **WHITE DC ON** switch. Observe **GREEN DC ON** lamp is **ON**
10. Ensure load bank is **ON** and cooling fans should begin spinning
11. Switch the load bank to **300 AMP**; verify the voltage at the load bank is **28.0 (MIN) - 28.9 (MAX) Volts DC**. Adjust **R-67** on Interface Board to obtain correct voltage output
12. Move load bank switch to **AUTO**; verify the voltage range at the load bank is **16.0 thru 28.9 volts DC** and a minimum **1600 AMPS** at full load
13. Observe **Amber Warning** lamp flashes if **DC output** volts drops below **21VDC**. **LET LOAD BANK COOL**, push **Black DC Off** switch

NOTE: The following test is for Dual Output Cable units.

14. Follow steps 1 thru 8
15. Push **GREEN DC ENABLE ON** switch; verify **GREEN DC ENABLE** lamp is **ON**
16. Push the **WHITE DC 1 ON** switch, observe **GREEN DC 1** lamp is **ON**
17. Follow steps 10 thru 13
18. Connect a load bank to the **DC OUTPUT CABLE 2**
19. Push the **WHITE DC 2 ON** switch, observe **GREEN DC 2** lamp is **ON**
20. Repeat steps 13 and 17 using **DC OUTPUT CABLE 2**. Let load bank **COOL**, push **Black DC 2 Off** switch
21. Connect load banks to **DC OUTPUT CABLES 1 and 2. (Set Load for 300 Amps Each)**
22. Push the **WHITE DC 1 & 2 ON** switches, observe **GREEN DC 1 & 2** lamps are **ON**
23. Observe voltage on digital multi meter, it should indicate 28(MIN) VDC with loads. Reduce loads to 0 Amps
24. Let load banks **COOL**, push **Black DC 1 & 2 Off** switches
25. Disconnect load banks
26. Turn disconnect on main power outlet to **OFF**
27. Final inspect the unit for missing, loose, components
28. When the unit passes all test, release unit for normal operation

NOTE: The following test is for External Voltage Adjustable units

29. Follow steps 1 thru 2
30. Open control panel door, locate the Interface Board, insure voltage adjust switch (SW1) is in the external (EXT) position
31. Insure over-volt trip switch (**SW2**) is in the low (**LOW**) position. Close control panel door
32. Connect AC input power cable to the main power outlet and apply electrical power
33. Set current limiting switch on front panel to highest setting (2000 AMP)
34. Turn GPU main disconnect switch to **ON**
35. Ensure green main power lamp is **ON**, DC voltmeter is indicating 28.5 volts and no other fault lamps are on
36. Connect a load bank switch to the DC OUTPUT CABLE 1, set load bank to 2000 Amps and ensure load bank switch is **OFF**
37. Connect a digital multi meter to the test points on the load bank
38. Push **GREEN DC ENABLE ON** switch; verify **GREEN DC ENABLE** lamp is **ON**
39. Adjust voltage control knob on control panel to 28 VDC mark
40. Push **WHITE DC 1 ON** switch, observe **GREEN DC 1** lamp is **ON**
41. Ensure load bank is **ON** and cooling fans should be spinning
42. Switch the load bank to 300 AMP; verify the voltage at the load bank is 28.0 (min) – 28.9 (max) Volts DC. Adjust the External Voltage control knob on the control panel to obtain correct voltage output
43. Move load bank switch to **AUTO**; verify the voltage range at the load bank is 16.0 thru 28.9 volts DC and a minimum 1600 Amps at full load



		28.5 VDC Ground Power Unit		
	Models	112850S0000	112850S0100	112850S0200
	112850D0000	112850D0100/AV	112850D0100-A5	112850D0200
112860S0000	112860S0100	112860S0100-A4	112860S0100-A6	112860S0200
112860D0000	112860D0100	112860SD100-A5	112860D0200	112860SD200-A5

5.2.3 Converter Commissioning (*continued*)

44. Observe amber warning lamp flashes if DC output volts drops below 21 VDC. LET LOAD BANK COOL, push black DC OFF switch
45. Disconnect load bank
46. Turn disconnect on main power outlet to **OFF**
47. Final inspect the unit for missing or loose components
48. When the unit passes all tests release for normal operation

5.3 SWITCHING ON

NOTE: Before switching the set on for the first time after installation, check that the cabling has been correctly installed.

1. Connect AC input power cable to the main power outlet and apply electrical power
2. Set current limiting switch on front panel to as needed
3. Turn **GPU** main disconnect switch to **ON (RIGHT/HORIZONTAL)**
4. Ensure green main input power lamp is **ON**, DC voltmeter is indicating 28.5 volts, and no other fault lamps are on

Note: Ensure DC output power is not on and DC lamps are off

5. For all models, connect the DC output cable (s) to the aircraft DC socket. Ensure cable plug is fully inserted into the socket
6. Push the **WHITE DC ON** switch. Observe **GREEN DC ON** lamp is **ON**
7. The unit will operate normally
8. Push **BLACK DC OFF** switch to stop
9. Turn **GPU** main disconnect switch to **OFF (LEFT/VERTICAL)**
10. Disconnect DC cable from aircraft. Disconnect AC input power cable and stow cables on GPU

NOTE: The following steps are for Dual Output Cable units



WARNING!

Do not use DC Cable 2 for starting aircraft engines 300 amps maximum output.

11. Follow steps 1 thru 5
12. Push **GREEN DC ENABLE ON** switch; verify **GREEN DC ENABLE** lamp is **ON**
13. Push the **WHITE DC 1 or 2 ON** switches; observe **GREEN DC 1 or 2 lamps are ON. (USE BOTH CABLES IF NEEDED)**
14. Push **BLACK DC OFF** switches to stop
15. Push **RED DC ENABLE OFF** switch
16. Turn **GPU** main disconnect switch to **OFF (LEFT/VERTICAL)**
17. Disconnect DC cable (s) from aircraft. Disconnect AC input power cable and stow cables on GPU

NOTE: The following test is for External Voltage Adjustable units

18. Follow steps 1 thru 4
19. Connect the DC output cable(s) to the aircraft DC socket. Ensure cable plug is fully inserted into the socket
20. Adjust voltage control knob on control panel to 28 VDC mark
21. Push the **WHITE DC 1 ON** switch, observe **GREEN DC 1** lamps is **ON**
22. The unit will operate normally
23. Push **BLACK DC OFF** switch to stop
24. Turn GPU main disconnect switch to **OFF (left/vertical)**
25. Disconnect DC cable from aircraft. Disconnect AC input power cable and stow cables on GPU



WARNING!

Even when switched off, a few components inside the set remain "live". Only trained personnel should be allowed to work on set.

5.4 EMERGENCY STOP

In an emergency, to immediately shut off the system, the red Emergency Stop push button on the Control Panel must be pressed. Bear in mind, however, that the mains in feed is still "live". It can only be isolated by using suitable external means



		28.5 VDC Ground Power Unit		
	Models	112850S0000	112850S0100	112850S0200
	112850D0000	112850D0100/AV	112850D0100-A5	112850D0200
112860S0000	112860S0100	112860S0100-A4	112860S0100-A6	112860S0200
112860D0000	112860D0100	112860SD100-A5	112860D0200	112860SD200-A5

5.5 OUTPUT VOLTAGE DC ADJUSTMENT

WARNING!



Dangerous voltages in side control panel door!
This adjustment procedure shall be performed by qualified personnel!

1. Open control panel door.
2. Connect AC input power cable to the main power outlet and apply electrical power.
3. Turn **GPU** main disconnect switch to **ON (RIGHT/HORIZONTAL)**
4. Ensure green main input power lamp is **ON**, DC voltmeter is indicating 28.5 volts, and no other fault lamps are on.

NOTE: Ensure DC output power is not on and DC lamps are off.

5. For all models, connect a load bank to the **DC OUTPUT CABLE 1**, set load bank to **2000 Amps**, and ensure load bank switch is **OFF**.
6. Connect a digital multi meter to the test points on the load bank.

NOTE: The following test is for Single Output Cable units.

7. Push the **WHITE DC ON** switch. Observe **GREEN DC ON** lamp is **ON**.
8. Ensure load bank is **ON** and cooling fans should begin spinning.
9. Switch the load bank to **300 AMP**; verify the voltage at the load bank is **28.0(MIN) - 28.9(MAX) Volts DC**. Adjust **R-67** on Interface Board to obtain correct voltage output.
10. Move load bank switch to **AUTO**; verify the voltage range at the load bank is **16.0 thru 28.9 volts DC** and a minimum **1600 AMPS** at full load.
11. Observe **Amber Warning** lamp flashes if **DC output** volts drops below **21VDC**. **LET LOAD BANK COOL**, push **Black DC Off** switch.
12. Turn **GPU** main disconnect switch to **OFF (LEFT/VERTICAL)**
13. Disconnect DC cable from load bank. Disconnect AC input power cable and stow cables on GPU.

6.0 TROUBLE SHOOTING

6.1 GENERAL

NOTE In the event of a fault, the system fault messages should be evaluated using the chart below.

If the cause of the fault is within the converter and you cannot clear it with your own personnel, please contact your Tronair Service representative:

TRONAIR, Inc.
 1740 Eber Road
 Holland, Ohio 43528-9794 USA

Telephone: (419) 866-6301 or 800-426-6301
 Fax: (419) 867-0634
 E-mail: sales@tronair.com
 Website: www.tronair.com

It is very helpful for fault diagnosis if you can tell us the fault messages in the order in which they occurred.



	Models	112850S0000	112850S0100	112850S0200
112860S0000	112850D0000	112850D0100/AV	112850D0100-A5	112850D0200
112860D0000	112860S0100	112860S0100-A4	112860S0100-A6	112860S0200
	112860D0100	112860SD100-A5	112860D0200	112860SD200-A5

6.2 PROCEDURES IN THE EVENT OF MALFUNCTIONS

Follow the steps below in case of malfunctions:

Action Upon Fault Detection											
Fault Description	Condition	Fault Sense Location	Input Breaker	DC Output Contactor	SCR Firing Enable	(Green) Input Voltage LED	Amber Warning LED	Red Fault LED	Output Contact or LED	Recovery	Notes
None	Normal	Firing Board to Interface Board	ON	ON	Enabled	ON	OFF	OFF	ON	None	
Missing Phase	Any phase voltage missing (>5% of rated voltage)	Firing Board to Interface Board	Opened Immediately	Unit Power Is Off	Unit Power Is Off	Unit Power Is Off	Unit Power Is Off	Unit Power Is Off	Unit Power Is Off	Input Breaker Must be Cycled	
Input Overvoltage	Secondary AC Voltage >115% of max voltage range	Interface Board	Opened Immediately	Unit Power Is Off	Unit Power Is Off	Unit Power Is Off	Unit Power Is Off	Unit Power Is Off	Unit Power Is Off	Input Breaker Must be Cycled	
Input Under Voltage	Primary AC Voltage <85% of rated voltage	Interface Board	ON	ON	ON	BLINK	ON	OFF	ON	Automatic when condition changes	If input voltage is to low unit will brown out
Output Over Voltage	Output Voltage >103% of Max of 32.5V at unit output (> 33.5V)	Interface Board	ON	Opened After 100ms	Disabled Immediately	On	BLINK	BLINK	OFF	Input Breaker Must be Cycled	
Output Under Voltage	Output <97% of Min of 24 V at unit output (< 23.3V)	Interface Board	ON	ON	ON	ON	BLINK	OFF	ON	Automatic when condition changes	
Output High Over Current	Output Current > 2100A	Interface Board	ON	Opened After 100ms	Disabled Immediately	ON	ON	BLINK	OFF	Input Breaker Must be Cycled	
Transformer Over-Temperature	Any/All Core Temperature > 180°C	Transformer Thermal Switches to Interface Board	ON	Opened After 100ms	Disabled Immediately	ON	ON	ON	OFF	Input Breaker Must be Cycled	
SCR Over-Temperature	Any/All SCR Temperature > 82°C	SCR/Heatsink Thermal Switches to Interface Board	ON	Opened After 100ms	Disabled Immediately	ON	OFF	BLINK	OFF	Input Breaker Must be Cycled	



			28.5 VDC Ground Power Unit	
	Models	112850S0000	112850S0100	112850S0200
	112850D0000	112850D0100/AV	112850D0100-A5	112850D0200
112860S0000	112860S0100	112860S0100-A4	112860S0100-A6	112860S0200
112860D0000	112860D0100	112860SD100-A5	112860D0200	112860SD200-A5

6.3 MONITORS & FAULT INDICATION

The following LEDs are used to define the color/flashing status of the GPU on the Control Panel:

Condition	(Green) Input Power LED	(Amber) Warning LED	(Red) Fault LED	(Green) Output Contactor LED
Normal Operation/Output Switch On	On	Off	Off	On
Power Off <i>or</i> Missing Phase <i>or</i> Input Overvoltage	Off	Off	Off	Off
Input Undervoltage	*Blink*	On	Off	On
Output Overvoltage	On	*Blink*	*Blink*	Off
Output Undervoltage	On	*Blink*	Off	On
Output High Overcurrent (>2100A)	On	On	*Blink*	Off
Transformer Overtemperature	On	On	On	Off
SCR Overtemperature	On	Off	*Blink*	Off
Normal Operation/Output Enable Switch Off	On	Off	Off	Off
Emergency Stop Switch Pushed In	Off	Off	Off	Off

7.0 MAINTENANCE AND SERVICE

7.1 PREVENTIVE MAINTENANCE

7.1.1 General

Because of their construction, Tronair converters require practically no maintenance. The few operations necessary should be carried out carefully since they contribute to the trouble-free operation and increased service life of the installation.

7.1.2 Cleanliness

Always ensure that the system environment is kept as free as possible of dust, metal chips, lubricants, etc. Check at regular intervals, that all air inlets and outlets are free of dust and are not blocked by any obstructions, sheets of papers, etc. Air inlets (underside of the roof) should be vacuumed from time to time.

In no circumstances use compressed air since this can force dust particles into the interior and cause malfunctions.

7.1.3 Voltage Check

To ensure that the set is delivering the correct voltage we recommend that this be checked at regular intervals.

7.2 SERVICE

Prior to delivery each converter is subjected to a thorough check, which includes running at full load for a prolonged period, and the prescribed overload test. Faults should not normally occur during proper, careful handling. Faults cannot be entirely ruled out, however, if caused by transportation, unfavorable environmental or operating conditions, or incorrect operation.

If a fault occurs and you are unable to rectify this yourself with the aid of the fault table, please contact us at:

TRONAIR, Inc.
 1 Air Cargo Pkwy East
 Swanton, Ohio 43558 USA

Telephone: (419) 866-6301 or 800-426-6301
 Fax: (419) 867-0634
 E-mail: sales@tronair.com
 Website: www.tronair.com

With all enquiries please state the model number and serial number of the equipment. These are located on the front panel of the unit.



		28.5 VDC Ground Power Unit		
	Models	112850S0000	112850S0100	112850S0200
	112850D0000	112850D0100/AV	112850D0100-A5	112850D0200
112860S0000	112860S0100	112860S0100-A4	112860S0100-A6	112860S0200
112860D0000	112860D0100	112860SD100-A5	112860D0200	112860SD200-A5

8.0 ADDITIONAL INFORMATION

8.1 LED FUNCTIONS & ARRANGEMENTS

As described in Section 3, the system control is completely digital. System control software is comprised of measurements, evaluation of measurements, threshold control, and a programmable logic control (PLC) known as the User Program. The individual parts are fully integrated to operate together as a software control system. The most important function is that of the User Program. The PLC has digital inputs and outputs which converts the information coming from the hardware into a form recognizable by the User Program software. Each input and output is monitored by an LED, and all inputs and outputs, which are used, are shown on the control diagrams. Checking the status of these LED's is a quick and easy way of establishing the operational status of the converter, and is useful during fault-finding. An illuminated LED indicates a high potential (+24V) at the hardware digital input or output. If the LED is off, then the potential is low (0V).

9.0 GUARANTEES/LIMITATION OF LIABILITY

Tronair products are warranted to be free of manufacturing or material defects for a period of one year after shipment to the original customer. This is solely limited to the repair or replacement of defective components. This warranty does not cover the following items:

- Parts required for normal maintenance
- Parts covered by a component manufacturers warranty
- Replacement parts have a 90-day warranty from date of shipment

If you have a problem that may require service, contact Tronair immediately. Do not attempt to repair or disassemble a product without first contacting Tronair, any action may affect warranty coverage. When you contact Tronair be prepared to provide the following information:

- Product Model Number
- Product Serial Number
- Description of the problem

If warranty coverage is approved, either replacement parts will be sent or the product will have to be returned to Tronair for repairs. If the product is to be returned, a Return Material Authorization (RMA) number will be issued for reference purposes on any shipping documents. Failure to obtain a RMA in advance of returning an item will result in a service fee. A decision on the extent of warranty coverage on returned products is reserved pending inspection at Tronair. Any shipments to Tronair must be shipped freight prepaid. Freight costs on shipments to customers will be paid by Tronair on any warranty claims only. Any unauthorized modification of the Tronair products or use of the Tronair products in violation of cautions and warnings in any manual (including updates) or safety bulletins published or delivered by Tronair will immediately void any warranty, express or implied.

The obligations of Tronair expressly stated herein are in lieu of all other warranties or conditions expressed or implied. **Any unauthorized modification of the Tronair products or use of the Tronair products in violations of cautions and warnings in any manual (including updates) or safety bulletins published or delivered by Tronair will immediately void any warranty, express or implied and Tronair disclaims any and all liability for injury (WITHOUT LIMITATION and including DEATH), loss or damage arising from or relating to such misuse.**

10.0 APPENDICES

APPENDIX I	Wiring Diagram and Schedule – Single Output
APPENDIX II	Diagram and Schedule – Dual Output
APPENDIX III	Declaration of conformity



	Models	112850S0000	112850S0100	112850S0200
	112850D0000	112850D0100/AV	112850D0100-A5	112850D0200
112860S0000	112860S0100	112860S0100-A4	112860S0100-A6	112860S0200
112860D0000	112860D0100	112860SD100-A5	112860D0200	112860SD200-A5

Parts List

When ordering replacement parts/kits, please specify model, serial number and color of your unit.

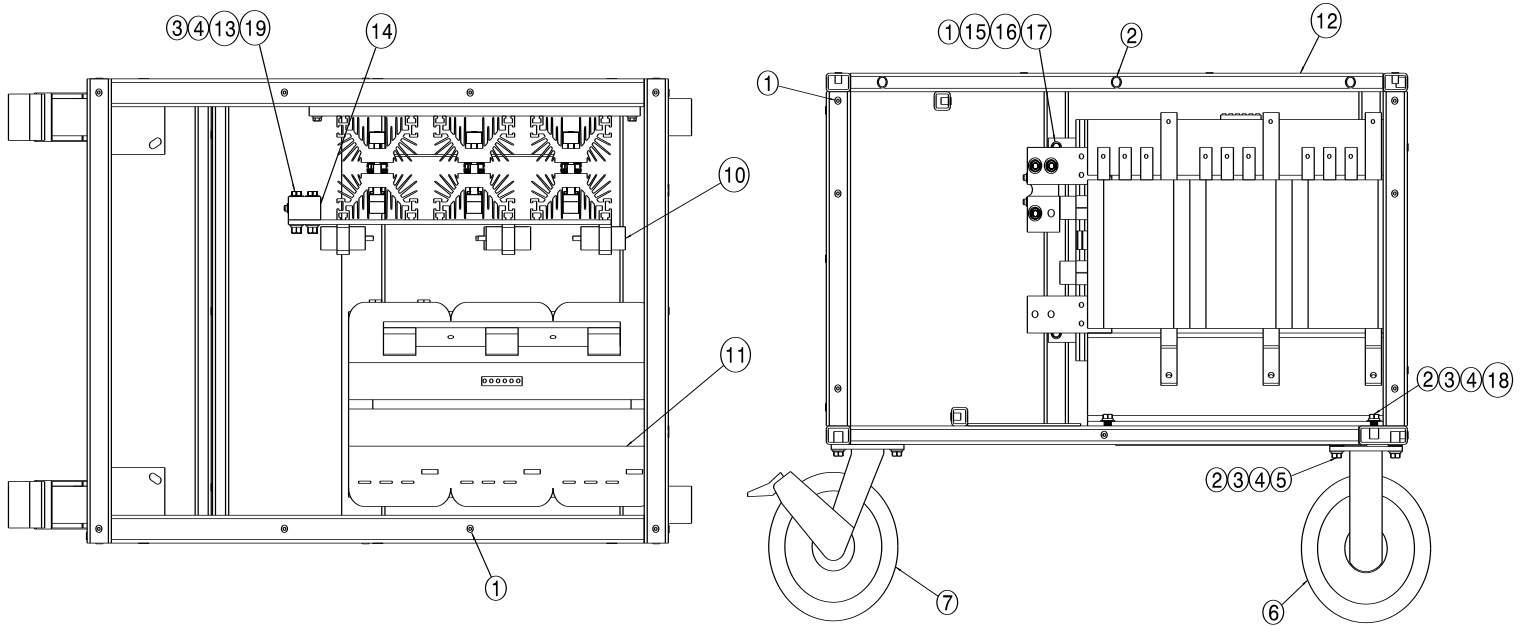

Item	Part Number	Description	Qty
1	G-1439-1050-S	Nutsert, Thinwall ¼ - 20	33
2	G-1439-1070-S	Nutsert, 3/8 – 16 Open End	24
3	G-1503-1070N	Flatwasher, 3/8 Narrow SS	34
4	G-1502-1070R	Lockwasher, 3/8 Regular SS	19
5	G-1112-107010	Bolt, 3/8 – 16 x 1.0 LG, HH SS	12
6	U-1112	Caster, Rigid	2
7	U-1085	Caster, Swivel	2
10	EC-2128	SCR Pak	1
11	Z-6943	Assy., Transformer	1
12	Z-6897-01	Weldment, Frame	1
	Z-6897-SP	Weldment, Frame (Special Paint)	1
13	G-1112-107020	Bolt, 3/8 - 16 2.0 LG, HH SS	4
14	13002	Shunt Resistor	1
15	G-1112-105020	Bolt, ¼ - 20 x 2, HH SS	4
16	G-1503-1050N	Flatwasher, ¼ Narrow SS	4
17	G-1502-1050R	Lockwasher, ¼ Regular SS	4
18	G-1112-107012	Bolt, 3/8 - 16 x 1 ¼ LG, HH SS	4
19	G-1500-1070	Nut, 3/8 – 16 HH SS	3
N/S	G-1351-03-SS	Rivet, 1/8 Open End SS	4
N/S	G-1580	Door, Latch Receptacle	2
N/S	12048	Split Polyloom ½, 36 in	1
N/S	12085	Split Polyloom 1, 36 in	1
N/S	13092	Cradle, Mounting	10



112860S0000
112860D0000

Models
112850D0000 112860S0100
112860D0100 112860S0100
112860D0100 112860SD100-A4

112850S0000 112860S0100
112850D0100/AV 112860S0100-A4
112860SD100-A5

28.5 VDC Ground Power Unit
112850S0100 112850S0200
112850D0100-A5 112850D0200
112860S0100-A6 112860S0200
112860D0200 112860SD200-A5

Parts List

When ordering replacement parts/kits, please specify model, serial number and color of your unit.

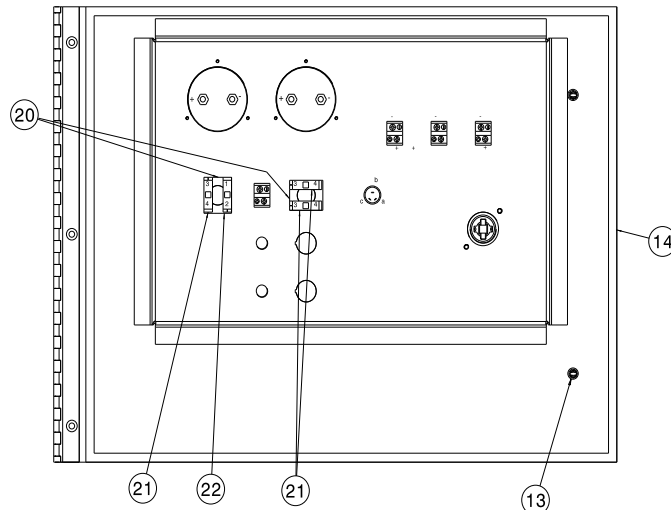
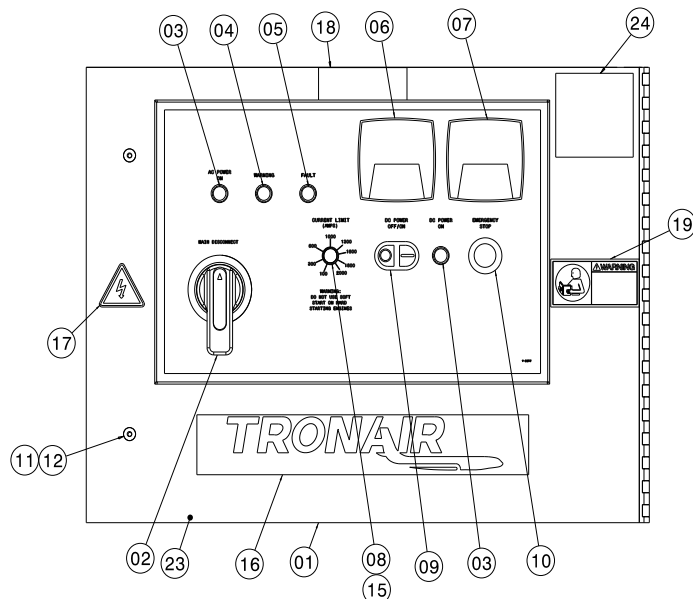

Item	Part Number	Description	Qty
1	S-2293	Door/Control panel	Ref
2	H-3155	Handle, Circuit Breaker	1
3	EC-2008-02	LED Green (Single)	2
		LED Green (Dual)	4
4	EC-2008	LED Amber	1
5	EC-2008-03	LED Red	1
6	14009	Voltmeter DC	1
7	14008	DC Ammeter	1
8	12031	Knob, DC	1
9	14131	Switch On/Off	1
10	14132	Switch, Emergency Stop	1
11	G-1577-19	Fastener, ¼ Turn	2
12	G-1579	Washer, Sealing ¼ Turn	2
13	G-1578	Retainer, ¼ Turn Fastener	2
14	H-3191*084.50	Tape, Neoprene Foam Seal	1
15	EC-2144-07	Potentiometer, 10K Sealed	1
16	V-1033	Label, Tronair	1
17	V-1050	Label, ISO Electrical	1
18	V-2097	Label, Warning	1
19	V-1986	Label, Read Manual	1
20	14142	Flange, Latch (Single)	2
		Flange, Latch (Dual)	4
21	14143	Block, Contact Green (Single)	3
		Block, Contact Green (Dual)	5
22	14144	Block, Contact Red (Single)	1
		Block, Contact Red (Dual)	3
23	V-2258	Label, Panel	1
24	V-2258	Label, Serial Number CE	1
N/S	EC-2165	P6 Interface Harness	1
N/S	14130	Switch, Power On/Off	1



112860S0000
112860D0000

Models
112850D0000
112860S0100
112860D0100

112850S0000
112850D0100/AV
112860S0100-A4
112860SD100-A5

28.5 VDC Ground Power Unit
112850S0100
112850D0100-A5
112860S0100-A6
112860D0200

112850S0200
112850D0200
112860S0200
112860SD200-A5

This page left blank intentionally.



28.5 VDC Ground Power Unit

Models	112850S000	112850S0100	112850S0200
112850D0000	112850D0100/AV	112850D0100-A5	112850D0200
112860S0000	112860S0100	112860S0100-A4	112860S0200
112860D0000	112860D0100	112860SD100-A5	112860SD200-A5

Parts List

When ordering replacement parts/kits, please specify model, serial number and color of your unit.

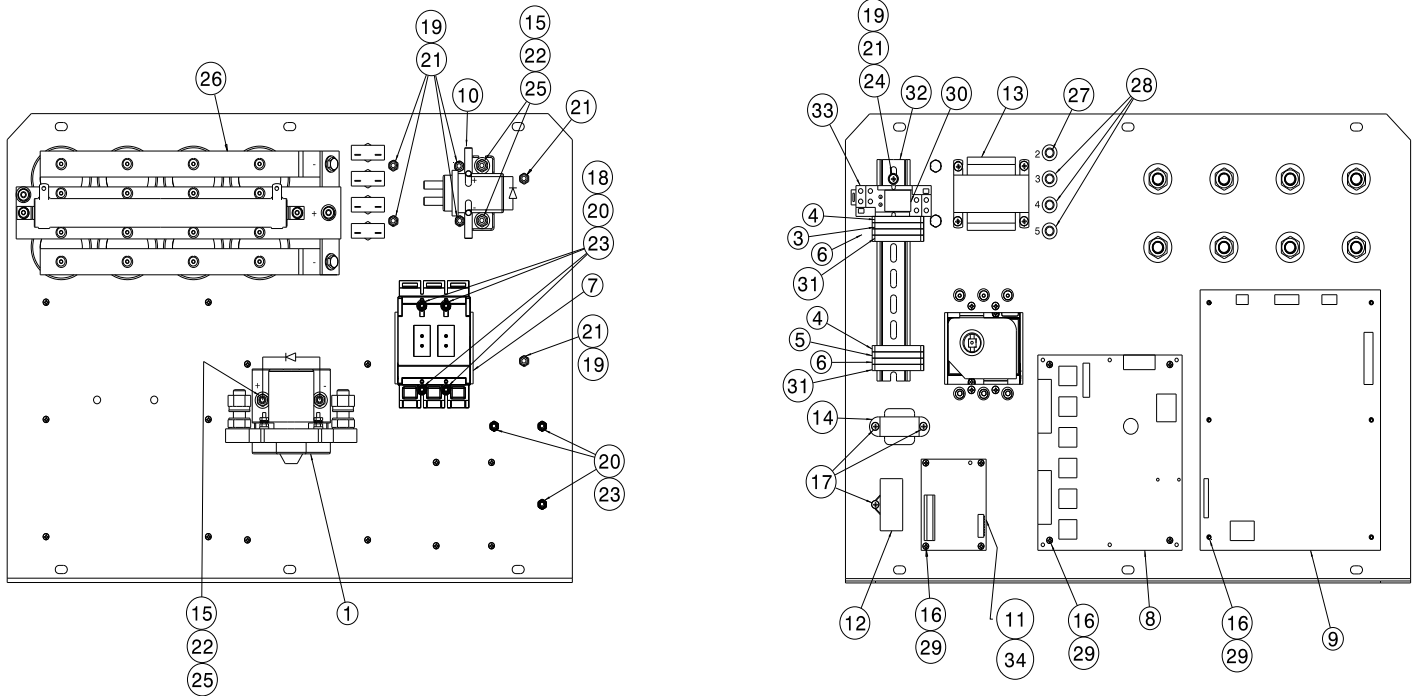

Item	Part Number	Description	Qty
1	EC-1027	Contact, DC Output (Single)	1
3	EC-2065	Terminal Block, 4 Pole Black	1
4	EC-2083	Terminal Block, 4 Pole Lt Gray	2
5	EC-2084	Terminal Block, 4 Pole Red	1
6	EC-2065	Plate, End 4CTerminal Block	2
7	EC-2169	Circuit Breaker, 100 Amp	1
8	EC-2127	Firing Board	1
9	EC-2129	Interface Board	1
10	EC-2177	Relay, High Circuit	1
11	EC-2138	Fan Speed Controller w/Probe	1
12	EC-2141	Capacitor, Fan Motor	1
13	EC-2157	Transformer, Control 115/24 VAC, 4A	1
14	EC-2156	Transformer, 117V – 24VT	1
15	G-1112-105006	Bolt, ¼ - 20 x ¾ HH SS	4
16	G-1497-101002	SCR, 6-32 x ¼ RD HD PH SS	28
17	G-1497-102006	SCR, 8-32 x ½ RD HD PH SS	3
18	G-1497-101034	SCR, 6-32 x 3 ½ RD HD PH SS	4
19	G-1497-103104	SCR, 10-32 x ½ RD HD PH SS	6
20	G-1501-1010	Stopnut, 6-32 Elastic SS	7
21	G-1501-1031	Stopnut, 10-32 Elastic SS	7
22	G-1501-1050	Stopnut, ¼ - 20 Elastic SS	6
23	G-1503-1010N	Flatwasher, 6 Narrow SS	8
24	G-1503-1030N	Flatwasher, 10 Narrow SS	7
25	G-1503-1050N	Flatwasher, ¼ Narrow SS	4
26	Z-6900	Assembly, Capacitors	1
27	EC-2159	Circuit Breaker, 25 Amp	1
28	12002	Circuit Breaker, 5 Amp	3
29	12034	PCB Stand Offs	14
30	13064	Relay, Compact 24VDC (Single)	1
		Relay, Compact 24VDC (Dual)	2
31	13070	Anchor, Din Rail End	2



			28.5 VDC Ground Power Unit	
	Models	112850S0000	112850S0100	112850S0200
	112850D0000	112850D0100/AV	112850D0100-A5	112850D0200
112860S0000	112860S0100	112860S0100-A4	112860S0100-A6	112860S0200
112860D0000	112860D0100	112860SD100-A5	112860D0200	112860SD200-A5

Parts List

When ordering replacement parts/kits, please specify model, serial number and color of your unit.

Item	Part Number	Description	Qty
32	13072*008.50	Rail, Din	1
33	13074	Socket, Relay 11 PIN (Single)	1
		Socket, Relay 11 PIN (Dual)	2
37	EC-2163	P2 Interface Board Harness	1
38	EC-2164	P3 Interface Board Harness	1
39	EC-2166	P8 Interface Board Harness	1
40	EC-2167	P9 Interface Board Harness	1
41	EC-2176	Connector, Lag 3/8 Stud	6
42	G-1501-1020	Stopnut, 8-32 Elastic SS	7
43	4002-6	Diode, Power	1
N/S	EC-2085	Diode, Plug-In Relay Socket (Single)	1
		Diode, Plug-In Relay Socket (Dual)	2
N/S	EC-2158	Temp Sensor	1

The following parts are for the 112860S0100-A4 unit ONLY: (all other parts are for all units)

Item	Part Number	Description	Qty
N/S	CRHX1806-71	Plug, Input Male	Installed on the input cable
N/S	CRHX1806-62	Plug, Insert	Loose with unit, to be installed by customer
N/S	CRHX1806-91	Receptacle, Female	Loose with unit, to be installed by customer



112860S0000
112860D0000

Models
112850D0000
112860S0100
112860D0100

112850S0000
112850D0100/AV
112860S0100-A4
112860SD100-A5

28.5 VDC Ground Power Unit
112850S0100
112850D0100-A5
112860S0100-A6
112860D0200

112850S0200
112850D0200
112860S0200
112860SD200-A5

Parts List

When ordering replacement parts/kits, please specify model, serial number and color of your unit.

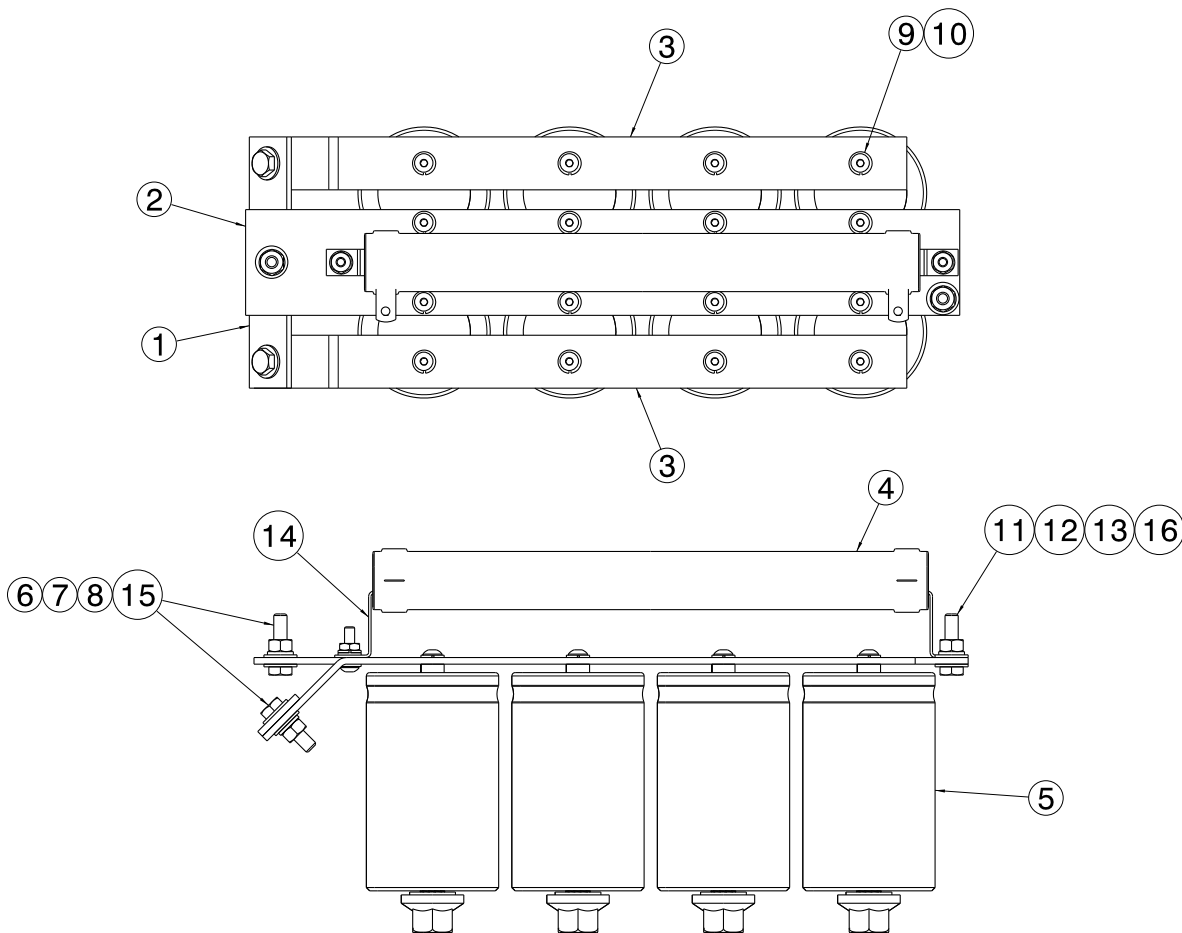

Item	Part Number	Description	Qty
1	J-4324	Buss Bar Bridge	1
2	J-4303	Buss Bar	1
3	J-4304	Buss Bar	2
4	EC-2134	Resistor	1
5	EC-2133	Capacitor	8
6	G-1112-105010	Bolt, ¼ - 20 x 1 LG, HH SS	4
7	G-1503-1050N	Flatwasher, ¼ Narrow SS	8
8	G-1502-1050R	Lockwasher, ¼ SS	4
9	G-1593-07SS	Lockwasher, Internal Tooth, #10	16
10	G-1476-103103	SCR, #10-32 SOC BUT HD CAP	16
11	G-1476-103106	SCR, #10-32 SOC BUT HD CAP SS	16
12	G-1503-1030N	Flatwasher, #10 SS	4
13	G-1500-1031	Nut, #10 – 32 Hex SS	2
14	H-3156	Resistor, Bracket	2
15	G-1500-1050	Nut, ¼ – 20 Hex SS	4
16	G-1500-1050	Nut, ¼ - 20 Hex SS	4
18	H-3173	Nut, Plastic Capacitor	8
N/S	EC-1034-01	Terminal Ring	4



APPENDIX I

Wiring Diagram and Schedule Single Output

INSTRUCTION
PAGE 1 OF 4DOCUMENT NUMBER:
INS-1993

Model: 1128X0S0X00– Wiring Schedule (Single Output 50/60 Hertz)

DATE: 01/2011

REV: 04

NOTE: REFER TO WIRING DIAGRAM INS-2007

WIRE LETTER	WIRE SIZE/COLOR	FROM	TO
A	20/BLACK	P-6 HARNESS CONNECTOR (PIN 5)	EMERGENCY STOP SWITCH SW1 TERMINAL (3)
B	20/BLACK	P-6 HARNESS CONNECTOR (PIN 6)	EMERGENCY STOP SWITCH SW2 TERMINAL (1)
C	20/BLACK	P-6 HARNESS CONNECTOR (PIN 18)	EMERGENCY STOP SWITCH SW2 TERMINAL (2)
D	20/BLACK	P-6 HARNESS CONNECTOR (PIN 17)	EMERGENCY STOP SWITCH SW1 TERMINAL (4)
E	20/GREEN	P-6 HARNESS CONNECTOR (PIN 7)	DC POWER ON/OFF SWITCH SW3 TERMINAL (4)
F	20/GREEN	P-6 HARNESS CONNECTOR (PIN 20)	DC POWER ON/OFF SWITCH SW3 & SW4 TERMINALS (3)
G	20/GREEN	P-6 HARNESS CONNECTOR (PIN 19)	DC POWER ON/OFF SWITCH SW4 TERMINAL (4)
H	20/BLACK	P-6 HARNESS CONNECTOR (PIN 1)	INPUT POWER ON LAMP L1 TERMINAL (PLUS)
I	20/GREEN	P-6 HARNESS CONNECTOR (PIN 13)	INPUT POWER ON LAMP L1 TERMINAL (MINUS)
J	20/BLACK	P-6 HARNESS CONNECTOR (PIN 2)	WARNING LAMP L2 TERMINAL (PLUS)
K	20/GREEN	P-6 HARNESS CONNECTOR (PIN 14)	WARNING LAMP L2 TERMINAL (MINUS)
L	20/BLACK	P-6 HARNESS CONNECTOR (PIN 3)	FAULT LAMP L3 TERMINAL (PLUS)
M	20/GREEN	P-6 HARNESS CONNECTOR (PIN 15)	FAULT LAMP L3 TERMINAL (MINUS)
N	20/BLACK	P-6 HARNESS CONNECTOR (PIN 9)	CURRENT LIMIT POT SW5 TERMINAL (a)
O	20/GREEN	P-6 HARNESS CONNECTOR (PIN 21)	CURRENT LIMIT POT SW5 TERMINAL (c)
P	20/BLACK	P-6 HARNESS CONNECTOR (PIN 10)	CURRENT LIMIT POT SW5 TERMINAL (b)
Q	20/BLACK	P-6 HARNESS CONNECTOR (PIN 24)	DC CURRENT METER M1 TERMINAL (PLUS)
R	20/GREEN	P-6 HARNESS CONNECTOR (PIN 12)	DC CURRENT METER M1 TERMINAL (MINUS)
S	20/BLACK	P-6 HARNESS CONNECTOR (PIN 8)	DC VOLT METER M2 TERMINAL (PLUS)
T	20/GREEN	P-6 HARNESS CONNECTOR (PIN 22)	DC VOLT METER M2 TERMINAL (MINUS)
U	20/BLACK	P-6 HARNESS CONNECTOR (PIN 4)	DC 1 ON LAMP L4 TERMINAL (PLUS)
V	20/GREEN	P-6 HARNESS CONNECTOR (PIN 16)	DC 1 ON LAMP L4 TERMINAL (MINUS)
W	20/BLACK	BLACK TERMINAL BLOCK (1)	LATCH RELAY K1 TERMINALS (9 & 10)
X	20/BLACK	P-3 HARNESS CONNECTOR (PIN 1)	LATCH RELAY K1 TERMINAL (13)
Y	20/GREEN	P-3 HARNESS CONNECTOR (PIN 5)	LATCH RELAY K1 TERMINAL (14)
Z	20/GREEN	P-3 HARNESS CONNECTOR (PIN 8)	DC SHUNT (PLUS)
A A	20/GREEN	P-3 HARNESS CONNECTOR (PIN 4)	DC SHUNT (MINUS)
B B	20/BLACK	SCR BUS BAR (PLUS)	P-3 HARNESS CONNECTOR (PIN 3)



WIRE LETTER	WIRE SIZE/COLOR	FROM	TO
	4/0 BLACK		DC CONTACTOR CONT1 CONTACT
C C	20/RED	P-8 HARNESS CONNECTOR (PIN 1)	P-5 HARNESS CONNECTOR (PIN 1)
D D	20/RED	P-8 HARNESS CONNECTOR (PIN 3)	P-5 HARNESS CONNECTOR (PIN 3)
E E	20/RED	P-8 HARNESS CONNECTOR (PIN 5)	P-5 HARNESS CONNECTOR (PIN 5)
F F	20/RED	P-9 HARNESS CONNECTOR (PIN 1)	P-3 HARNESS CONNECTOR (PIN 1)
G G	20/RED	P-9 HARNESS CONNECTOR (PIN 2)	P-3 HARNESS CONNECTOR (PIN 2)
H H	20/BLACK	P-9 HARNESS CONNECTOR (PIN 3)	P-3 HARNESS CONNECTOR (PIN 3)
I I	20/BLACK	P-9 HARNESS CONNECTOR (PIN 4)	P-3 HARNESS CONNECTOR (PIN 4)
J J	20/BLACK	P-9 HARNESS CONNECTOR (PIN 5)	P-3 HARNESS CONNECTOR (PIN 5)
K K	20/GREEN	P-9 HARNESS CONNECTOR (PIN 8)	P-3 HARNESS CONNECTOR (PIN 8)
L L	20/BLACK	P-9 HARNESS CONNECTOR (PIN 9)	P-3 HARNESS CONNECTOR (PIN 9)
M M	20/BLACK	P-9 HARNESS CONNECTOR (PIN 10)	P-3 HARNESS CONNECTOR (PIN 10)
N N	20/GREEN	P-9 HARNESS CONNECTOR (PIN 11)	P-3 HARNESS CONNECTOR (PIN 11)
O O	20/BLACK	P-9 HARNESS CONNECTOR (PIN 12)	P-3 HARNESS CONNECTOR (PIN 12)
P P	20/BLACK	SCR BUS BAR (PLUS)	BLACK TERMINAL BLOCK (1)
Q Q	20/BLACK	LATCH RELAY K1 TERMINAL (5)	DC CONTACTOR CONT1 COIL
R R	20/BLACK	BLACK TERMINAL BLOCK (1)	BLEED RESISTOR SOLENOID SOL1 COIL
S S	20/GREEN	LT. GRAY TERMINAL BLOCK (4)	DC CONTACTOR CONT1 COIL
T T	20/RED	FAN CONTROLLER PC BOARD PCB3 TERMINAL (L)	RED TERMINAL BLOCK (3)
U U	20/RED	P-2 HARNESS CONNECTOR (PIN 6)	CIRCUIT BREAKER CB4
V V	20/RED	P-2 HARNESS CONNECTOR (PIN 13)	TRANSFORMER T3 (RED WIRE)
W W	20/GREEN	SCR BUS BAR (MINUS)	LT. GRAY TERMINAL BLOCK (4)
X X	20/GREEN	LT. GRAY TERMINAL BLOCK (4)	BLEED RESISTOR SOLENOID SOL1 COIL
Y Y	16/RED	CIRCUIT BREAKER CB2	GFCI OUTLET SOC1 TERMINAL (HOT) OR BLACK TERMINAL BLOCK (8)
Z Z	16/WHITE	TRANSFORMER T1 TERMINAL (A2)	GFCI OUTLET SOC1 LINE TERMINAL (WHITE) OR YELLOW TERMINAL BLOCK (10)
A B	20/RED	CONTROL TRANSFORMER T2 (RED WIRE)	CIRCUIT BREAKER CB5
A C	12/RED	CIRCUIT BREAKER CB6	230 VOLT AC OUTLET (SOC 1)
A D	16/RED	CIRCUIT BREAKER CB2	RED TERMINAL BLOCK (6)
A E	6/BLACK	SCR BUS BAR (PLUS)	CAPACITOR ASSEMBLY BUS BAR (PLUS) BLEED RESISTOR R1
A F	6/BLACK	SCR BUS BAR (MINUS)	CAPACITOR ASSEMBLY BUS BAR (MINUS) BLEED RESISTOR SOLENOID SOL1 (CONTACT)
A G	20/GREEN	TRANSFORMER THERMO TERMINAL BLOCK	P-2 HARNESS CONNECTOR (PIN 8)
A H	20/GREEN	TRANSFORMER THERMO TERMINAL BLOCK	P-2 HARNESS CONNECTOR (PIN 9)
A I	20/BLACK	SHUNT-TRIP CIRCUIT BREAKER (BLACK WIRE)	P-2 HARNESS CONNECTOR (PIN 5)
A J	20/GREEN	SHUNT-TRIP CIRCUIT BREAKER (BLACK WIRE)	P-2 HARNESS CONNECTOR (PIN 12)



WIRE LETTER	WIRE SIZE/COLOR	FROM	TO
A K	20/RED	CIRCUIT BREAKER CB5	P-2 HARNESS CONNECTOR (PIN 7)
A L	20/GREEN	TRANSFORMER T3 (RED WIRE)	P-2 HARNESS CONNECTOR (PIN 14)
A M	20/RED	TRANSFORMER T1 TERMINAL (X3)	P-2 HARNESS CONNECTOR (PIN 3)
	4/0 BLACK		SCR MODULE MOD1 TERMINAL SCR# 5
A N	20/RED	TRANSFORMER T1 TERMINAL (X2)	P-2 HARNESS CONNECTOR (PIN 2)
	4/0 BLACK		SCR MODULE MOD1 TERMINAL SCR# 3
A O	20/RED	TRANSFORMER T1 TERMINAL (X1)	P-2 HARNESS CONNECTOR (PIN 1)
	4/0 BLACK		SCR MODULE MOD1 TERMINAL SCR# 1
A P	20/BLACK	TRANSFORMER T2 (BLACK WIRE)	CIRCUIT BREAKER CB3
A Q	20/RED	CIRCUIT BREAKER CB3	RED TERMINAL BLOCK (6)
A R	20/GREEN	TRANSFORMER T3 (RED/YELLOW WIRE)	P-2 HARNESS CONNECTOR (PIN 11)
A S	20/RED	TRANSFORMER T3 (RED WIRE)	CIRCUIT BREAKER CB4
A T	16/RED	TRANSFORMER T1 TERMINAL (A1)	CIRCUIT BREAKER CB2
A V		NOT USED	NOT USED
A W	16/WHITE	TRANSFORMER T1 TERMINAL (A2)	LT.GRAY TERMINAL BLOCK (5)
A X		NOT USED	NOT USED
A Y	20/BLACK	RED TERMINAL BLOCK (3)	UNIT COOLING FAN FAN1 (BLACK WIRE)
A Z	20/RED	RED TERMINAL BLOCK (6)	FAN CONTROL PCB PCB3 TERMINAL (L)
B A	20/GREEN	LT GRAY TERMINAL BLOCK (5)	FAN CONTROL PCB PCB3 TERMINAL (N)
B C	20/BLUE	FAN CONTROL PCB PCB3 TERMINAL (F)	UNIT COOLING FAN FAN1 (BLUE WIRE)
B D	20/BROWN	LT GRAY TERMINAL BLOCK (2)	UNIT COOLING FAN FAN1 (BROWN WIRE)
B E		NOT USED	NOT USED
B F		NOT USED	NOT USED
B G		NOT USED	NOT USED
B H	6/BLACK	SHUNT-TRIP CIRCUIT BREAKER (L1)	TRANSFORMER T1 TERMINAL (H3)
B I	6/BLACK	SHUNT-TRIP CIRCUIT BREAKER (L2)	TRANSFORMER T1 TERMINAL (H2)
B J	6/BLACK	SHUNT-TRIP CIRCUIT BREAKER (L3)	TRANSFORMER T1 TERMINAL (H1)
B K		NOT USED	NOT USED
B L		NOT USED	NOT USED
B M		NOT USED	NOT USED
B N	12/WHITE	TRANSFORMER T1 TERMINAL (A4)	230 VOLT AC OUTLET (SOC 1)
B O		NOT USED	NOT USED
B P		NOT USED	NOT USED
B Q		NOT USED	NOT USED
B R	4/0 BLACK	SCR BUS BAR (PLUS)	DC CONTACTOR CONT1 MAIN CONTACT
B S		NOT USED	NOT USED



WIRE LETTER	WIRE SIZE/COLOR	FROM	TO
B T	6/BLACK	BLEED RESISTOR R1	BLEED RESISTOR SOLENOID SOL1 MAIN CONTACT
B U	12/RED	TRANSFORMER T1 TERMINAL (A3)	CIRCUIT BREAKER CB6



APPENDIX II

Wiring Diagram and Schedule Dual Output



INSTRUCTION
PAGE 1 OF 4

DOCUMENT NUMBER:
INS-1998

Model: 1128X0D0XXX– Wiring Schedule (Dual Output 50/60 Hertz)

DATE: 01/2011

REV: 03

NOTE: REFER TO WIRING DIAGRAM INS-1992

WIRE LETTER	WIRE SIZE/COLOR	FROM	TO
A	20/BLACK	P-6 HARNESS CONNECTOR (PIN 5)	EMERGENCY STOP SWITCH SW1 TERMINAL (3)
B	20/BLACK	P-6 HARNESS CONNECTOR (PIN 6)	EMERGENCY STOP SWITCH SW2 TERMINAL (1)
C	20/BLACK	P-6 HARNESS CONNECTOR (PIN 18)	EMERGENCY STOP SWITCH SW2 TERMINAL (2)
D	20/BLACK	P-6 HARNESS CONNECTOR (PIN 17)	EMERGENCY STOP SWITCH SW1 TERMINAL (4)
E	20/GREEN	P-6 HARNESS CONNECTOR (PIN 7)	DC ENABLE ON SWITCH SW3 TERMINAL (4)
F	20/GREEN	P-6 HARNESS CONNECTOR (PIN 20)	DC ENABLE ON/OFF SWITCH SW3 & SW4 TERMINALS (3)
G	20/GREEN	P-6 HARNESS CONNECTOR (PIN 19)	DC ENABLE OFF SWITCH SW4 TERMINAL (4)
H	20/BLACK	P-6 HARNESS CONNECTOR (PIN 1)	INPUT POWER ON LAMP L1 TERMINAL (PLUS)
I	20/GREEN	P-6 HARNESS CONNECTOR (PIN 13)	INPUT POWER ON LAMP L1 TERMINAL (MINUS)
J	20/BLACK	P-6 HARNESS CONNECTOR (PIN 2)	WARNING LAMP L2 TERMINAL (PLUS)
K	20/GREEN	P-6 HARNESS CONNECTOR (PIN 14)	WARNING LAMP L2 TERMINAL (MINUS)
L	20/BLACK	P-6 HARNESS CONNECTOR (PIN 3)	FAULT LAMP L3 TERMINAL (PLUS)
M	20/GREEN	P-6 HARNESS CONNECTOR (PIN 15)	FAULT LAMP L3 TERMINAL (MINUS)
N	20/BLACK	P-6 HARNESS CONNECTOR (PIN 9)	CURRENT LIMIT POT SW5 TERMINAL (a)
O	20/GREEN	P-6 HARNESS CONNECTOR (PIN 21)	CURRENT LIMIT POT SW5 TERMINAL (c)
P	20/BLACK	P-6 HARNESS CONNECTOR (PIN 10)	CURRENT LIMIT POT SW5 TERMINAL (b)
Q	20/BLACK	P-6 HARNESS CONNECTOR (PIN 24)	DC CURRENT METER M1 TERMINAL (PLUS)
R	20/GREEN	P-6 HARNESS CONNECTOR (PIN 12)	DC CURRENT METER M1 TERMINAL (MINUS)
S	20/BLACK	P-6 HARNESS CONNECTOR (PIN 8)	DC VOLT METER M2 TERMINAL (PLUS)
T	20/GREEN	P-6 HARNESS CONNECTOR (PIN 22)	DC VOLT METER M2 TERMINAL (MINUS)
U	20/BLACK	P-6 HARNESS CONNECTOR (PIN 4)	DC ENABLE ON LAMP L4 TERMINAL (PLUS)
V	20/GREEN	P-6 HARNESS CONNECTOR (PIN 16)	DC ENABLE ON LAMP L4 TERMINAL (MINUS)
W	20/BLACK	BLACK TERMINAL BLOCK (1)	LATCH RELAY K1 TERMINALS (9 & 10)
X	20/BLACK	P-3 HARNESS CONNECTOR (PIN 1)	LATCH RELAY K1 TERMINAL (13) OR BLACK TERMINAL BLOCK (7)
Y	20/GREEN	P-3 HARNESS CONNECTOR (PIN 5)	DC 1 POWER OFF SWITCH SW7 TERMINAL (2)
			DC 2 POWER OFF SWITCH SW9 TERMINAL (1)
			OR LATCH RELAY K1 TERMINAL (14)



WIRE LETTER	WIRE SIZE/COLOR	FROM	TO
Z	20/GREEN	P-3 HARNESS CONNECTOR (PIN 8)	DC SHUNT (PLUS)
A A	20/GREEN	P-3 HARNESS CONNECTOR (PIN 4)	DC SHUNT (MINUS)
B B	20/BLACK	SCR BUS BAR (PLUS)	P-3 HARNESS CONNECTOR (PIN 3)
C C	20/RED	P-8 HARNESS CONNECTOR (PIN 1)	P-5 HARNESS CONNECTOR (PIN 1)
D D	20/RED	P-8 HARNESS CONNECTOR (PIN 3)	P-5 HARNESS CONNECTOR (PIN 3)
E E	20/RED	P-8 HARNESS CONNECTOR (PIN 5)	P-5 HARNESS CONNECTOR (PIN 5)
F F	20/RED	P-9 HARNESS CONNECTOR (PIN 1)	P-3 HARNESS CONNECTOR (PIN 1)
G G	20/RED	P-9 HARNESS CONNECTOR (PIN 2)	P-3 HARNESS CONNECTOR (PIN 2)
H H	20/BLACK	P-9 HARNESS CONNECTOR (PIN 3)	P-3 HARNESS CONNECTOR (PIN 3)
I I	20/BLACK	P-9 HARNESS CONNECTOR (PIN 4)	P-3 HARNESS CONNECTOR (PIN 4)
J J	20/BLACK	P-9 HARNESS CONNECTOR (PIN 5)	P-3 HARNESS CONNECTOR (PIN 5)
K K	20/GREEN	P-9 HARNESS CONNECTOR (PIN 8)	P-3 HARNESS CONNECTOR (PIN 8)
L L	20/BLACK	P-9 HARNESS CONNECTOR (PIN 9)	P-3 HARNESS CONNECTOR (PIN 9)
M M	20/BLACK	P-9 HARNESS CONNECTOR (PIN 10)	P-3 HARNESS CONNECTOR (PIN 10)
N N	20/GREEN	P-9 HARNESS CONNECTOR (PIN 11)	P-3 HARNESS CONNECTOR (PIN 11)
O O	20/BLACK	P-9 HARNESS CONNECTOR (PIN 12)	P-3 HARNESS CONNECTOR (PIN 12)
P P	20/BLACK	SCR BUS BAR (PLUS)	BLACK TERMINAL BLOCK (1)
Q Q	20/BLACK	LATCH RELAY K1 TERMINAL (5)	DC CONTACTOR CONT1 COIL
R R	20/BLACK	BLACK TERMINAL BLOCK (1)	BLEED RESISTOR SOLENOID SOL1 COIL
S S	20/GREEN	LT. GRAY TERMINAL BLOCK (4)	DC 1 CONTACTOR CONT1 COIL
			DC 2 CONTACTOR CONT2 COIL
T T	2/RED	FAN CONTROLLER PC BOARD PCB3 TERMINAL (L)	RED TERMINAL BLOCK (3)
U U	20/RED	P-2 HARNESS CONNECTOR (PIN 6)	CIRCUIT BREAKER CB4
V V	20/RED	P-2 HARNESS CONNECTOR (PIN 13)	TRANSFORMER T3 (RED WIRE)
W W	20/GREEN	SCR BUS BAR (MINUS)	LT. GRAY TERMINAL BLOCK (4)
X X	20/GREEN	LT. GRAY TERMINAL BLOCK (4)	BLEED RESISTOR SOLENOID SOL1 COIL
Y Y	12/RED	CIRCUIT BREAKER CB2	GFCI OUTLET SOC1 TERMINAL (HOT) OR RED TERMINAL BLOCK (8)
Z Z	12/WHITE	TRANSFORMER T1 TERMINAL (A2)	GFCI OUTLET SOC1 LINE TERMINAL (WHITE) OR LT. GRAY TERMINAL BLOCK (10)
A B	20/RED	CONTROL TRANSFORMER T2 (RED WIRE)	CIRCUIT BREAKER CB5
A C	12/RED	CIRCUIT BREAKER CB6	230 VOLT AC OUTLET (SOC1)
A D	16/RED	CIRCUIT BREAKER CB2	RED TERMINAL BLOCK (6)



WIRE LETTER	WIRE SIZE/COLOR	FROM	TO
A E	6/BLACK	SCR BUS BAR (PLUS)	CAPACITOR ASSEMBLY BUS BAR (PLUS)
			BLEED RESISTOR R1
A F	6/BLACK	SCR BUS BAR (MINUS)	CAPACITOR ASSEMBLY BUS BAR (MINUS)
			BLEED RESISTOR SOLENOID SOL1 (CONTACT)
A G	20/GREEN	TRANSFORMER THERMO TERMINAL BLOCK	P-2 HARNESS CONNECTOR (PIN 8)
A H	20/GREEN	TRANSFORMER THERMO TERMINAL BLOCK	P-2 HARNESS CONNECTOR (PIN 9)
A I	20/BLACK	SHUNT-TRIP CIRCUIT BREAKER (BLACK WIRE)	P-2 HARNESS CONNECTOR (PIN 5)
A J	20/GREEN	SHUNT-TRIP CIRCUIT BREAKER (BLACK WIRE)	P-2 HARNESS CONNECTOR (PIN 12)
A K	20/RED	CIRCUIT BREAKER CB5	P-2 HARNESS CONNECTOR (PIN 7)
A L	20/WHITE	TRANSFORMER T3 (RED WIRE)	P-2 HARNESS CONNECTOR (PIN 14)
A M	20/RED	TRANSFORMER T1 TERMINAL (X3)	P-2 HARNESS CONNECTOR (PIN 3)
	4/0 BLACK		SCR MODULE MOD1 TERMINAL SCR# 5
A N	20/RED	TRANSFORMER T1 TERMINAL (X2)	P-2 HARNESS CONNECTOR (PIN 2)
	4/0 BLACK		SCR MODULE MOD1 TERMINAL SCR# 3
A O	20/RED	TRANSFORMER T1 TERMINAL (X1)	P-2 HARNESS CONNECTOR (PIN 1)
	4/0 BLACK		SCR MODULE MOD1 TERMINAL SCR# 1
A P	20/BLACK	TRANSFORMER T2 (BLACK WIRE)	CIRCUIT BREAKER CB3
A Q	20/RED	CIRCUIT BREAKER CB3	RED TERMINAL BLOCK (6)
A R	20/GREEN	TRANSFORMER T3 (RED/YELLOW WIRE)	P-2 HARNESS CONNECTOR (PIN 11)
A S	20/RED	TRANSFORMER T3 (RED WIRE)	CIRCUIT BREAKER CB4
A T	16/RED	TRANSFORMER T1 TERMINAL (A1)	CIRCUIT BREAKER CB2
A V	20/BLACK	DC CABLE 1 ON SWITCH SW6 TERMINAL (4)	DC 1 ON LAMP L5 TERMINAL (PLUS)
			LATCH RELAY 1 K1 TERMINALS (8 & 13)
A W	16/WHITE	TRANSFORMER T1 TERMINAL (A2)	LT.GRAY TERMINAL BLOCK (5)
A X	20/GREEN	DC CABLE 1 OFF SWITCH SW7 TERMINAL (1)	DC 1 ON LAMP L5 TERMINAL (MINUS)
			LATCH RELAY 1 K1 TERMINAL (14)
A Y	20/BLACK	RED TERMINAL BLOCK (3)	UNIT COOLING FAN FAN1 (BLACK WIRE)
A Z	20/RED	RED TERMINAL BLOCK (6)	FAN CONTROL PCB PCB3 TERMINAL (L)
B A	20/GREEN	LT.GRAY TERMINAL BLOCK (5)	FAN CONTROL PCB PCB3 TERMINAL (N)
B C	20/BLUE	FAN CONTROL PCB PCB3 TERMINAL (F)	UNIT COOLING FAN FAN1 (BLUE WIRE)
B D	20/BROWN	LT.GRAY TERMINAL BLOCK (2)	UNIT COOLING FAN FAN1 (BROWN WIRE)



WIRE LETTER	WIRE SIZE/COLOR	FROM	TO
B E	20/BLACK	DC CABLE 2 ON SWITCH SW8 TERMINAL (3)	DC 2 ON LAMP L6 TERMINAL (PLUS) LATCH RELAY 2 K2 TERMINALS (8 & 13)
B F	20/GREEN	DC 2 POWER OFF SWITCH SW9 TERMINAL (2)	DC 2 ON LAMP L6 TERMINAL (MINUS) LATCH RELAY 2 K2 TERMINAL (14)
B G		NOT USED	NOT USED
B H	6/BLACK	SHUNT-TRIP CIRCUIT BREAKER (L1)	TRANSFORMER T1 TERMINAL (H3)
B I	6/BLACK	SHUNT-TRIP CIRCUIT BREAKER (L2)	TRANSFORMER T1 TERMINAL (H2)
B J	6/BLACK	SHUNT-TRIP CIRCUIT BREAKER (L3)	TRANSFORMER T1 TERMINAL (H1)
B K	20/BLACK	BLACK TERMINAL BLOCK (7)	LATCH RELAY 2 K2 TERMINAL (12)
B L			DC CABLE 1 ON SWITCH SW6 TERMINAL (3) DC CABLE 2 ON SWITCH SW8 TERMINAL (4)
B M			LATCH RELAY 1 K1 TERMINAL (12)
B N	12/WHITE	TRANSFORMER T1 TERMINAL (A4)	230 VOLT AC OUTLET (SOC1)
B O	20/BLACK	NOT USED	NOT USED
B P	20/BLACK	BLACK TERMINAL BLOCK (1)	LATCH RELAY 2 K2 TERMINAL (9)
B Q	20/BLACK	LATCH RELAY 2 K2 TERMINAL (5)	DC 2 CONTACTOR CONT2 COIL
B R	4/0 BLACK	SCR BUS BAR (PLUS)	DC CONTACTOR CONT1 MAIN CONTACT TERMINAL
B S	4/0 BLACK	SCR BUS BAR (PLUS)	DC CONTACTOR CONT2 MAIN CONTACT TERMINAL
B T	6/BLACK	BLEED RESISTOR R1	BLEED RESISTOR SOLENOID SOL1 MAIN CONTACT
B U	12/RED	TRANSFORMER T1 TERMINAL (A3)	CIRCUIT BREAKER CB6



APPENDIX III

Declaration of Conformity



DECLARATION of CONFORMITY

The design, development and manufacture is in accordance with European Community guidelines

28.5 VDC Ground Power Unit

Relevant standards complied with by the machinery:

MIL-STD-704F

UL 1012

EN 55011

EN60146 part 1-1

EN 61000-6-2

NFPA 70

Identification of person empowered to sign on behalf of the Manufacturer:

A handwritten signature in cursive script that reads "Patrick Funch". The signature is written in black ink and is positioned above a horizontal line.

Quality Assurance Representative