

# 24 Volt Dry Charged Batteries for Turbo Prop and Jet Application



## G-6381E

- 24 Volts
- 43 AH at the 1 Hour Rate
- 70 Amps 30 Minute Emergency Capacity
- 445 CCA at 0° F for 60 Seconds
- 80 Lbs. (Filled)
- 1.285 SG Electrolyte, 9 Quarts



## G-638E

- 24 Volts
- 37 AH at the 1 Hour Rate
- 60 Amps 30 Minute Emergency Capacity
- 375 CCA at 0° F for 60 Seconds
- 73 Lbs. (Filled)
- 1.285 SG Electrolyte, 9 Quarts



## G-639E

- 24 Volts
- 24 AH at the 1 Hour Rate
- 40 Amps 30 Minute Emergency Capacity
- 345 CCA at 0° F for 60 Seconds
- 55 Lbs. (Filled)
- 1.285 SG Electrolyte, 5 Quarts



## G-640E

- 24 Volts
- 14 AH at the 1 Hour Rate
- 25 Amps 30 Minute Emergency Capacity
- 180 CCA at 0° F for 60 Seconds
- 34 Lbs. (Filled)
- 1.285 SG Electrolyte, 3 Quarts



## G-641

- 24 Volts
- 18 AH at the 1 Hour Rate
- 30 Amps 30 Minute Emergency Capacity
- 275 CCA at 0° F for 60 Seconds
- 41.5 Lbs. (Filled)
- 1.285 SG Electrolyte, 4 Quarts

### G-6381E

- Avions Marcel Dassault: Fan Jet Falcon Series C, D, E, F
- Beech: 65-90, 65-A90, 99, 99A, A99, A99A, 100, 200, 200T, 300, A100, A100 A, B90, B100, C90, E90, F90
- Bell: 204B, 205A, 205-A, 212, 412
- Cessna: 208, 208B, 425, 500, 501, 550, 551, S550
- Cessna Aircraft Company: 560, 560XL
- Embraer: EMB-110P1, EMB-110P2
- Gates Learjet Inc: 23, 24 Series, 25 Series, 28 Series, 29 Series, 31, 31A Series, 35 Series, 36 Series, 55, 55B, 55C Series
- Gulfstream American Corporation: G-159
- Israel Aircraft Industries, Ltd: 1121, 1121A, 1121B, 1123, 1124
- Lockheed-Georgia Company: 1329-23 Series
- Mitsubishi: MU-2B, -10, -15, -20, -25, -26, -26A, -30, -35, -36, -36A, -40, -60
- Piper Aircraft Corporation: PA-31T, -31T1, -31T2, PA-42 and PA-42-720 Series
- Raytheon (Beechcraft): 200 (A100-1(U-21), 200C, 200CT, 200T, A200(C-12A) or (C-12C), A200CT(FWC-12D) or (RC-12D), or (C12F) or (RC-12G) or (RG-12H) or (RC-12K) or (RC-12P), B200, B200C, (C-12F) or (UC-12F) or (UC-12M) or (C12-R), B200CT, B200T, 300, B300, 300LW and B300C
- Rockwell International Corporation: NA-265 Series,
- Aero Commander 680T, 680V, 680W, 690, 690A

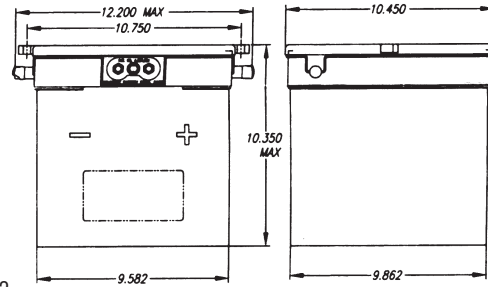

### G-639E

- British Aerospace: DH.125-400A, HS.125-600A, HS.125-700A, BH.125-600A, BAE.125-800A
- Hawker Siddeley, Beechcraft Hawker: DH-125, HS-125, BH-125
- Messerschmidt-Bolkow-Blohm GMBH: BO-105S

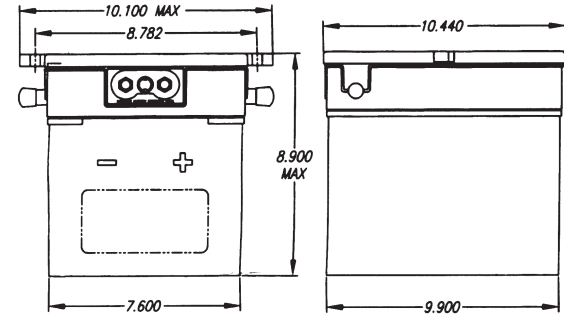

### G-640E

- Beech: 65, 70 Wing installation only

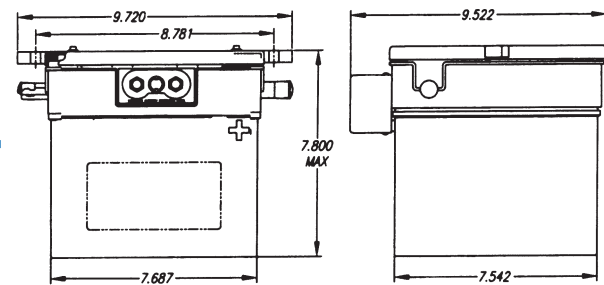

### G-638E

- Avions Marcel Dassault: Fan Jet Falcon Series C, D, E, F
- Beech: 65-90, 65-A90, 99, 99A, A99, A99A, 100, A100, A100 A, B90, B100, C90, E90, F90
- Embraer: EMB-110P1, EMB-110P2
- Gates Learjet Inc: 23, 24 Series, 25 Series, 28 Series, 29 Series, 31, 31A Series, 35 Series, 36 Series, 55, 55B, 55C Series
- Gulfstream American Corporation: G-159
- Israel Aircraft Industries, Ltd: 1121, 1121A, 1121B, 1123, 1124
- Lockheed-Georgia Company: 1329-23 Series
- Mitsubishi: MU-2B, -10, -15, -20, -25, -26, -26A, -30, -35, -36, -36A, -40, -60
- Rockwell International Corporation: NA-265 Series,
- Aero Commander 680T, 680V, 680W,

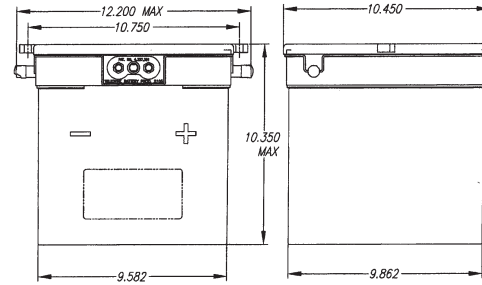

### G-641

- Bell Helicopter Textron: 206, 206A, 206B, 206B-1, 206B-3, 206L, 206L-1, 206L-3

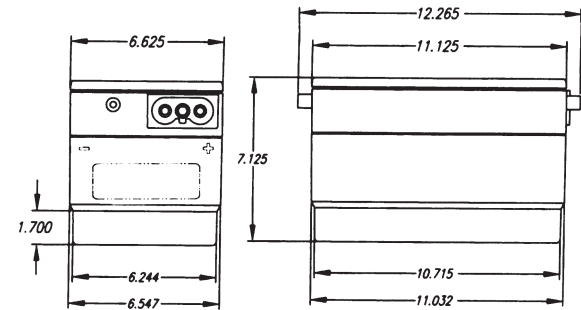

The Original Equipment Aircraft Battery

**TELEDYNE**  
BATTERY PRODUCTS  
A Teledyne Technologies Company

840 W. Brockton Ave., Redlands, CA 92374  
(800) 456-0070 • (909) 793-3131  
Fax: (909) 793-5818

[www.gillbatteries.com](http://www.gillbatteries.com)

G-6381E, G-639E, G-640E,  
G-641