

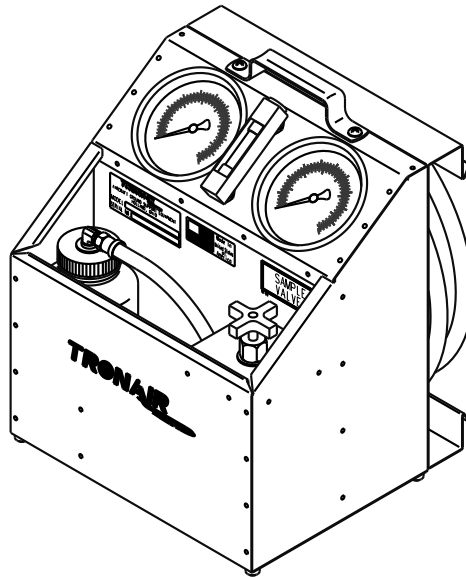

OPERATION & SERVICE MANUAL



**Model: 14-6871-6010
Anti-Skid Test Unit**

04/2020 – Rev. 09

REVISION	DATE	TEXT AFFECTED
06	08/2008	Major Revision
07	05/2019	Modified Parts List
08	07/2019	Modified Parts List
09	04/2020	Modified Parts List



TABLE OF CONTENTS

	<u>PAGE</u>
HYDRAULIC SCHEMATIC	1
1.0 GENERAL DESCRIPTION	2
2.0 OPERATION	2
2.1 BRAKE BLEEDING	2
2.2 OIL SAMPLE	2
2.3 BRAKE TEST	2
3.0 MAINTENANCE	2
3.1 STORAGE	2
4.0 CALIBRATION OF INSTRUMENTATION	3
4.1 SOURCE OF CALIBRATION	3
5.0 PARTS LIST	3
6.0 GUARANTEES/LIMITATION OF LIABILITY	3
7.0 APPENDICES	3

HYDRAULIC SCHEMATIC

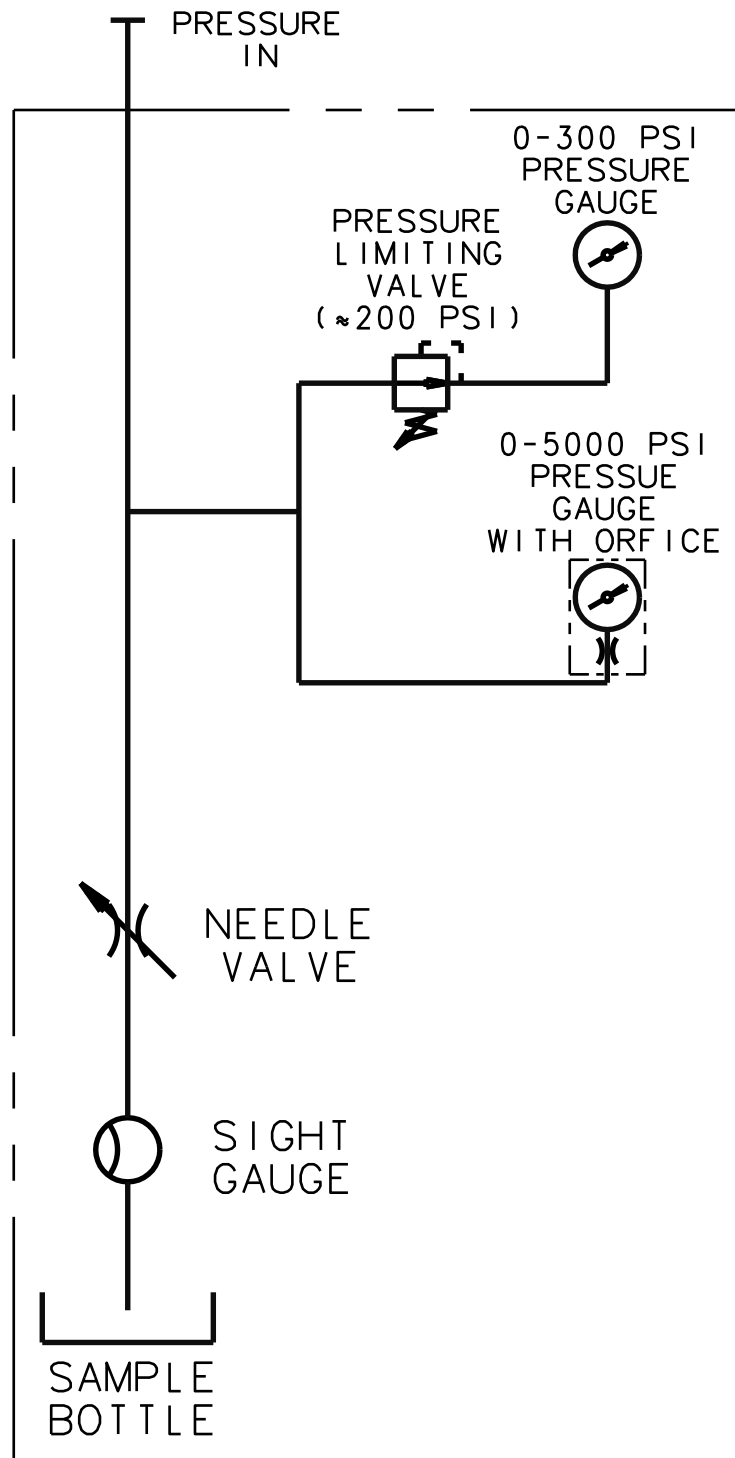

FIGURE 1 – Hydraulic Schematic

This product can not be modified without the written approval of Tronair, Inc. Any modifications done without written approval voids all warranties and releases Tronair, Inc., its suppliers, distributors, employees, or financial institutions from any liability from consequences that may occur. Only Tronair OEM replacement parts shall be used.

1.0 GENERAL DESCRIPTION

The Tronair 14-6871-6010 Anti-Skid Tester is designed to allow for brake bleeding, obtaining an oil sample, and measure brake pressures at the calipers.

- Weight:.....9 lbs
- Dimensions:
 - Depth:10.875 in (27.6 cm)
 - Width:.....12.875 in (32.7 cm)
 - Height:.....14.5 in (36.83 cm)
- Material:Aluminum Enclosure
- Sight Gauge
- 0-300 & 0-5,000 psi Pressure Gauges
- 15 inch Hose Assembly with plug

2.0 OPERATION



CAUTION!

All brake maintenance to be performed in accordance to Aircraft Manufacturer's Maintenance Manual & Government Regulations, as applicable

2.1 BRAKE BLEEDING

1. Connect the hose provided with unit to the brake caliper per aircraft manufacturer procedure.



CAUTION!

Make sure sample valve on unit is closed and brake pressure is at zero.

2. Open sample valve.
3. Observe oil for air through sight gauge.
4. Close valve when all air is removed. **(Do Not Overfill Bottle.)**

2.2 OIL SAMPLE

1. Repeat step 2.1.1 in Section 2.1 Brake Bleeding.
2. Unscrew lid on jar provided with unit and position clean sample bottle under outlet on bottom side of cap.
3. Open sample valve to obtain fluid sample per manufacturer's requirements. Close valve after sample is obtained.

2.3 BRAKE TEST

1. Test per manufacturer's maintenance manual.
2. Use sample valve to relieve pressure prior to disconnecting hose.

NOTE: Gauge Cutout Valve is set to prevent Low Pressure Gauge from exceeding 300 psig

3.0 MAINTENANCE

- Inspect prior to each use for signs of cracking or kinking, replace as necessary.
- Generally keep the entire unit clean and free from any contaminants. Visually inspect for any system leaks or damage. Correction of any problems prior to unit operation is imperative for safe operation.

3.1 STORAGE

Store the unit in a clean, dry area when not in use.

Ensure that all hoses are capped. The unit should be covered for the duration of unit storage to ensure cleanliness.



4.0 CALIBRATION OF INSTRUMENTATION

All gauges on the unit can be either returned to Tronair for calibration or certified by the end user if proper calibration equipment is available. Gauges returned to Tronair for calibration will be tested with standards traceable to N.I.S.T. (National Institute of Standards and Technology). Tronair recommends calibration of instrumentation at yearly intervals, but actual calibration dates may be based upon frequency of use and the end users quality system. For information on returning gauges for calibration, Reference **4.1 – Source of Calibration**.

4.1 SOURCE OF CALIBRATION

TRONAIR, Inc.
 1 Air Cargo Pkwy East
 Swanton, Ohio 43558 USA

Telephone: (419) 866-6301 or 800-426-6301
 Fax: (419) 867-0634
 E-mail: sales@tronair.com
 Website: www.tronair.com

5.0 PARTS LIST

Reference the following pages for ordering information of Replacement Parts and Kits.

6.0 GUARANTEES/LIMITATION OF LIABILITY

Tronair products are warranted to be free of manufacturing or material defects for a period of one year after shipment to the original customer. This is solely limited to the repair or replacement of defective components. This warranty does not cover the following items:

- a) Parts required for normal maintenance
- b) Parts covered by a component manufacturers warranty
- c) Replacement parts have a 90-day warranty from date of shipment

If you have a problem that may require service, contact Tronair immediately. Do not attempt to repair or disassemble a product without first contacting Tronair, any action may affect warranty coverage. When you contact Tronair be prepared to provide the following information:

- a) Product Model Number
- b) Product Serial Number
- c) Description of the problem

If warranty coverage is approved, either replacement parts will be sent or the product will have to be returned to Tronair for repairs. If the product is to be returned, a Return Material Authorization (RMA) number will be issued for reference purposes on any shipping documents. Failure to obtain a RMA in advance of returning an item will result in a service fee. A decision on the extent of warranty coverage on returned products is reserved pending inspection at Tronair. Any shipments to Tronair must be shipped freight prepaid. Freight costs on shipments to customers will be paid by Tronair on any warranty claims only. Any unauthorized modification of the Tronair products or use of the Tronair products in violation of cautions and warnings in any manual (including updates) or safety bulletins published or delivered by Tronair will immediately void any warranty, express or implied.

The obligations of Tronair expressly stated herein are in lieu of all other warranties or conditions expressed or implied. **Any unauthorized modification of the Tronair products or use of the Tronair products in violations of cautions and warnings in any manual (including updates) or safety bulletins published or delivered by Tronair will immediately void any warranty, express or implied and Tronair disclaims any and all liability for injury (WITHOUT LIMITATION and including DEATH), loss or damage arising from or relating to such misuse.**

7.0 APPENDICES

APPENDIX I Instrument Certification Notice

Parts List

When ordering Replacement Parts/Kits, please specify Model & Serial Number of your unit.

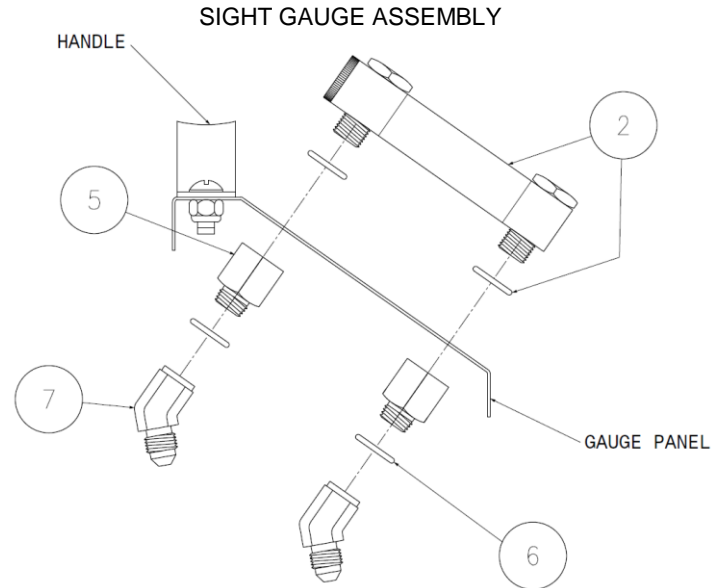
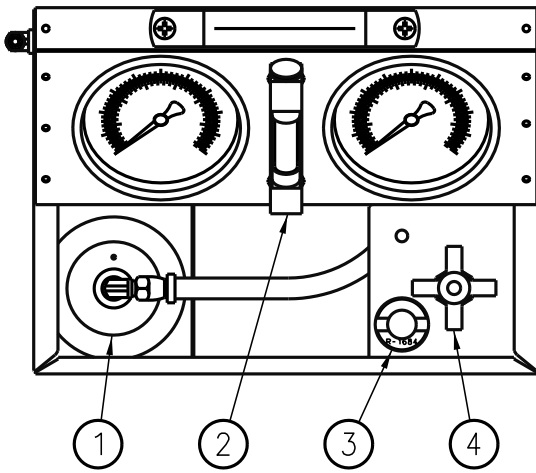

Item	Part Number	Description	Qty
1	Z-4280	Assembly, Bottle with Hose	1
3	14-6874-6000	Tool, Anti-Skid Spin-Up	1
4	See Page 6	Valve, Needle	1
	K-3024	Kit, Sight Gauge Replacement; consists of:	
2	HC-1383-03	Gauge, Sight	1
5	N-3111	Adapter, ¼ NPT	2
6	N-3116-011-01	Washer, ½ EPDM sealing	2
7	N-3105	45° Elbow, -4 JIC x -4 FNPT	2

Parts List

When ordering Replacement Parts/Kits, please specify Model & Serial Number of your unit.

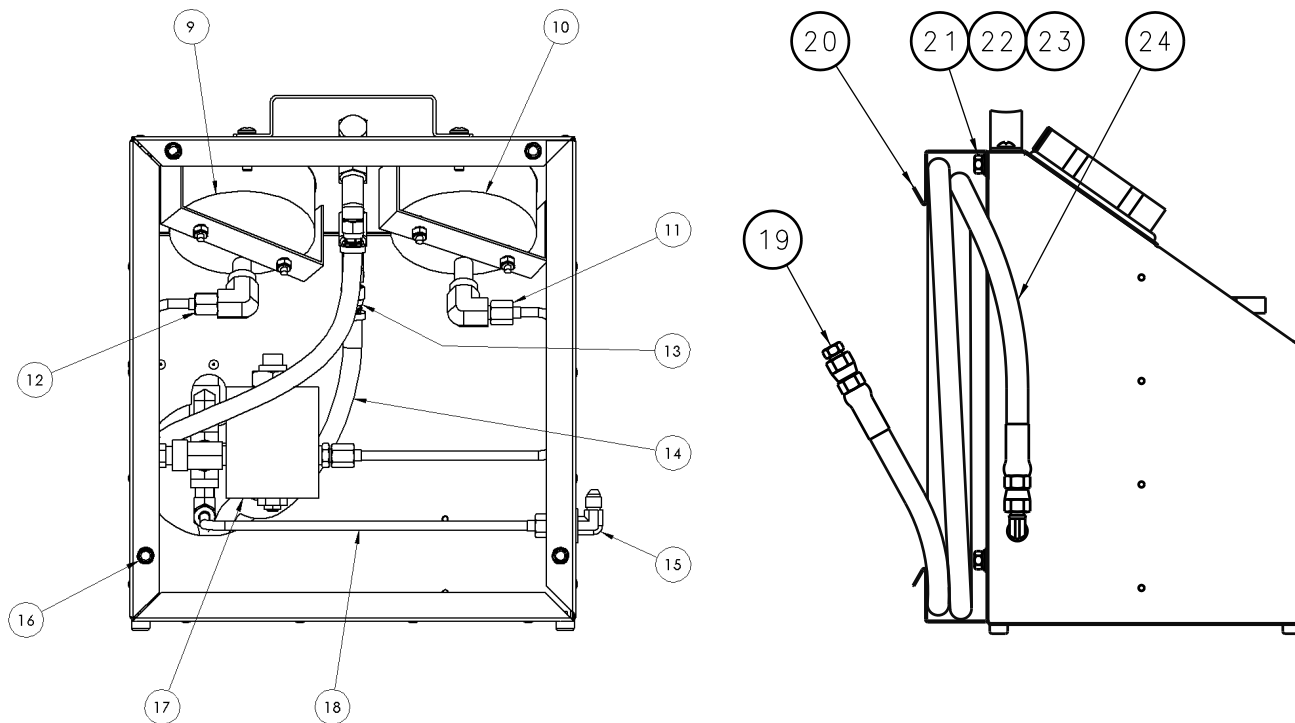

Item	Part Number	Description	Qty
9	HC-1399	Gauge, Pressure (0-5000 PSI)	1
10	HC-1423	Gauge, Pressure (0-300 PSI)	1
11	HC-1803	Assembly, Tube	1
12	HC-1227	Assembly, Tube	1
13	N-2026-01-S	Swivel, #4 JIC 37° x #4 Barbed Hose	1
14	TF-1132-03*11.5	Hose, EVA Semi-Clear, 1/4" I.D. x 11 1/2" long	1
15	N-2022-03-S	Elbow, 90° Male Bulkhead, #4 JIC 37°	1
17	HC-2857	Valve, Gauge Cutout	1
18	HC-1802	Assembly, Tube	1
19	N-2014-03-S	Plug	1
24	TF-1041-05*180	Assembly, Hose	1
	K-3026	Kit, Rear Panel Replacement; consists of:	
16	G-1439-1050-S	Nutsert, Open-End, 1/4-20	4
20	S-1598	Panel, Rear	1
21	G-1100-105006	Bolt, Hex Head, Grade 5, 1/4-20 x 3/4" long	4
22	G-1250-1050N	Flatwasher, 1/4 Narrow	4
23	G-1251-1050R	Lockwasher, 1/4 Regular	4

Parts List

When ordering Replacement Parts/Kits, please specify Model & Serial Number of your unit.

HC-1081-02 – Needle Valve Assembly

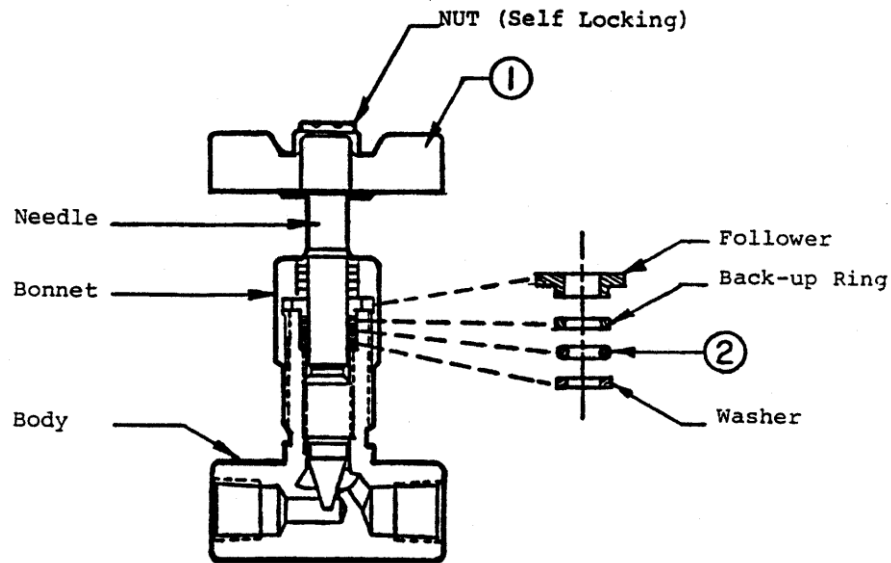

Item	Part Number	Description	Qty
1	HC-1082	Handle, Valve	1
2	HC-2006-011	O-Ring	1



APPENDIX I

Instrument Certification Notice



Instrument Certification Notice

The gauge Certificates of Calibration supplied for the gauge(s) on this unit contain the calibration data for the actual instrument calibrated, along with the calibration date of the **STANDARD** used to perform the calibration check.

The due date for re-calibration of the instrument should be based upon the date the instrument was placed in service in your facility. Re-calibration should be done on a periodic basis as dictated by the end user's quality system or other overriding requirements.

Note that Tronair, Inc. does not supply certificates of calibration on flow meters or pyrometers unless requested at the time of placed order. These instruments are considered reference indicators only and are not critical to the test(s) being performed on the aircraft.