

2.5 / 5 Gallon Chemical Jug With Locking Cap

Operation Manual

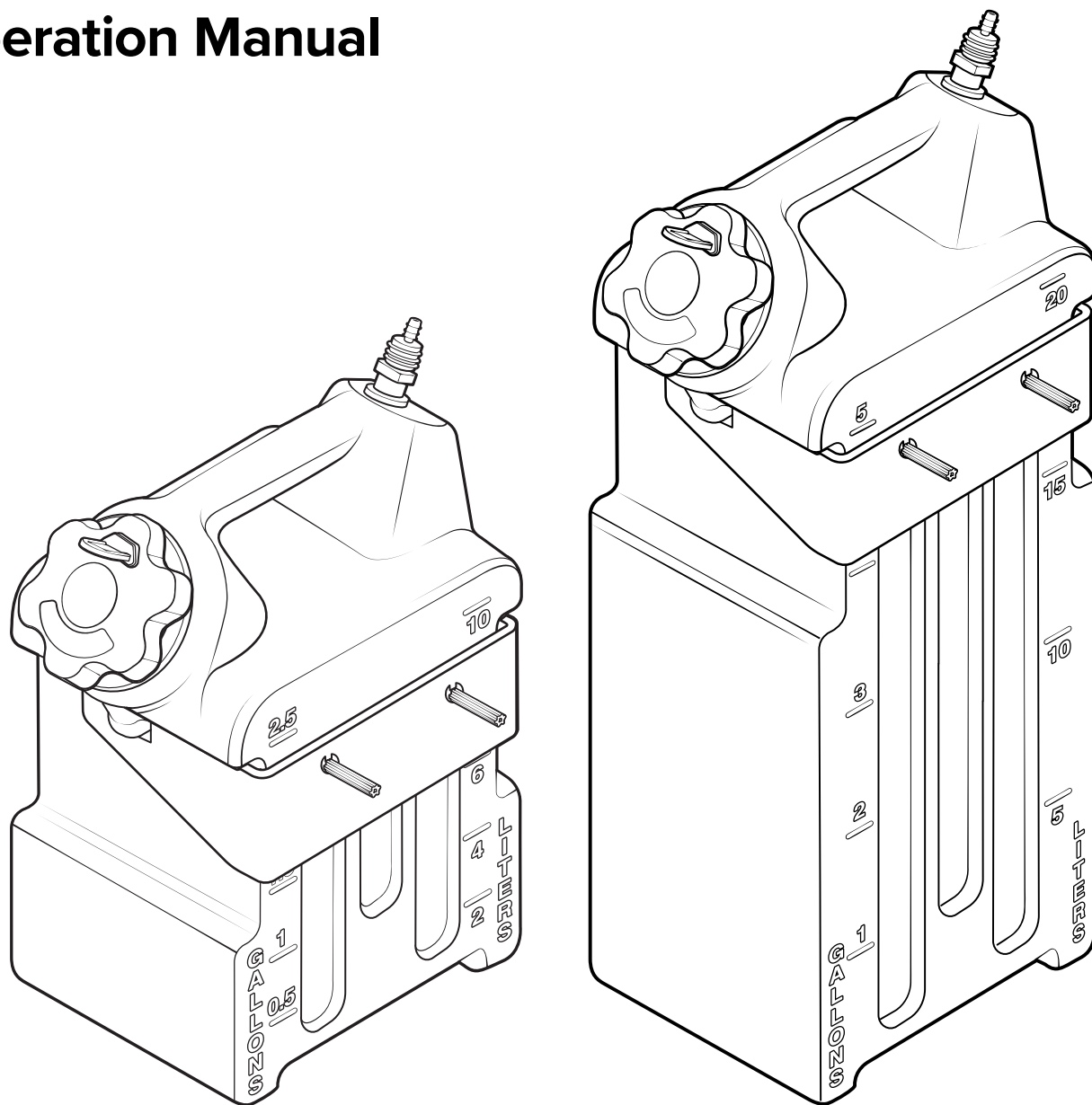

READ ALL INSTRUCTIONS BEFORE USING OR
SERVICING THIS UNIT. KEEP THIS MANUAL IN A
LOCATION THAT IS READILY AVAILABLE TO USERS
AND SERVICE TECHNICIANS.

English (Original Instructions)



Scan this code for
operation manual

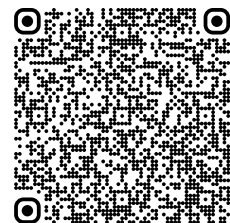

Safety

WARNING

PEOPLE OR OBJECTS CAN BE HURT OR DAMAGED IF THIS UNIT IS NOT USED CORRECTLY!



Failure to read all the instructions before operating the unit may result in personal injury or death from the improper use or the chemical solution. Anyone handling, operating or using the unit must read and understand the instructions in the manual. The buyer assumes all responsibility for safety and proper use in accordance with the instructions.



Using or servicing the unit without appropriate personal protective equipment (PPE) may result in serious injury such as burns, rashes, eye, throat or lung damage and death. Always wear PPE as indicated in the Safety Data Sheet (SDS) when using or servicing the unit. Protect eyes, skin, and lungs against drifting spray.



Chemical solutions may pose a health risk and death if they contact the skin or eyes, are inhaled or swallowed. Always read and follow all chemical safety precautions and handling instructions provided by the chemical manufacturer and the SDS associated with the chemical solution before using the unit.

Using the unit with fluid temperatures above 100°F (37.8°C) may result in scalding, burns, serious injury or death. DO NOT use a solution with a temperature above 100°F (37.8°C).



Operating the unit when damaged or leaking may result in exposure to chemical solutions, serious injury or death. Never use the unit if it is damaged or leaking.

Use of hydrocarbons and flammable products may result in explosions, fire and serious injury or death. Never use hydrocarbons or flammable products with the unit.



Mixing an alkaline with an acid may result in a chemical reaction. Overheating of the mixture may cause it to splatter caustic compounds or release hazardous fumes, gas and vapors. Always flush the unit with fresh water thoroughly when switching from an alkaline to an acid or an acid to an alkaline.

NOTICE

Servicing or modifying this unit with parts not listed in this manual may cause the unit to operate improperly. Do not use unauthorized parts when servicing the unit.

PROTECT THE ENVIRONMENT



Please dispose of packaging materials, old machine components, and hazardous fluids in an environmentally safe way according to local waste disposal regulations

Product Overview

Requirements

Liquid temperature range	40-100°F (4.4-37.8°C)
Chemical compatibility	Chemical products used with this equipment must be formulated for this type of application and compatible with unit materials and pump seals. For more information on chemical compatibility, consult the manufacturer or SDS for your product or contact our customer service department.

Specifications

	2.5 Gallon Jug	5 Gallon Jug
Capacity	2.5 gallons (9.5 liters)	5 gallons (18.9 liters)
Tubing/fitting sizes	Jugs with suction fitting option include fittings for ¼ in. (6.4 mm) inside diameter hose	

Options

Product		Capacity	Tank Color		Cap Color		Suction fitting	Rack
Jug (JGA)	-	2.5 gallons (2.5)	Natural (N)	-	Black (LIBK)	-	Not included (standard)	Not included (standard)
		5 gallons (5)			Blue (LIBL)		Suction (S)	Rack (R)
					Brown (LIBN)			Locking rack (LIR)
					Green (LIGN)			
					Orange (LIOR)			
					Purple (LIPL)			
					Red (LIRD)			
					White (LIWH)			
					Yellow (LIYL)			

When ordering add the bolded option codes to the item number as shown.

Examples:

- JGA-2.5N-LIBK-SR - 2.5 gallon natural jug with black locking cap, suction, and rack
- JGA-2.5N-LIBL-S - 2.5 gallon natural jug with blue locking cap and suction
- JGA-5N-LIGN-LIR - 5 gallon natural jug with green locking cap and locking rack
- JGA-5N-LIRD - 5 gallon natural jug with red locking cap

Product Components

Get to know the components that you will need to use, adjust or assemble.

1. Locking key
2. Locking cap
3. 2.5 gallon locking jug
4. 5 gallon locking jug
5. Suction fitting
6. Draw tube
7. Jug rack

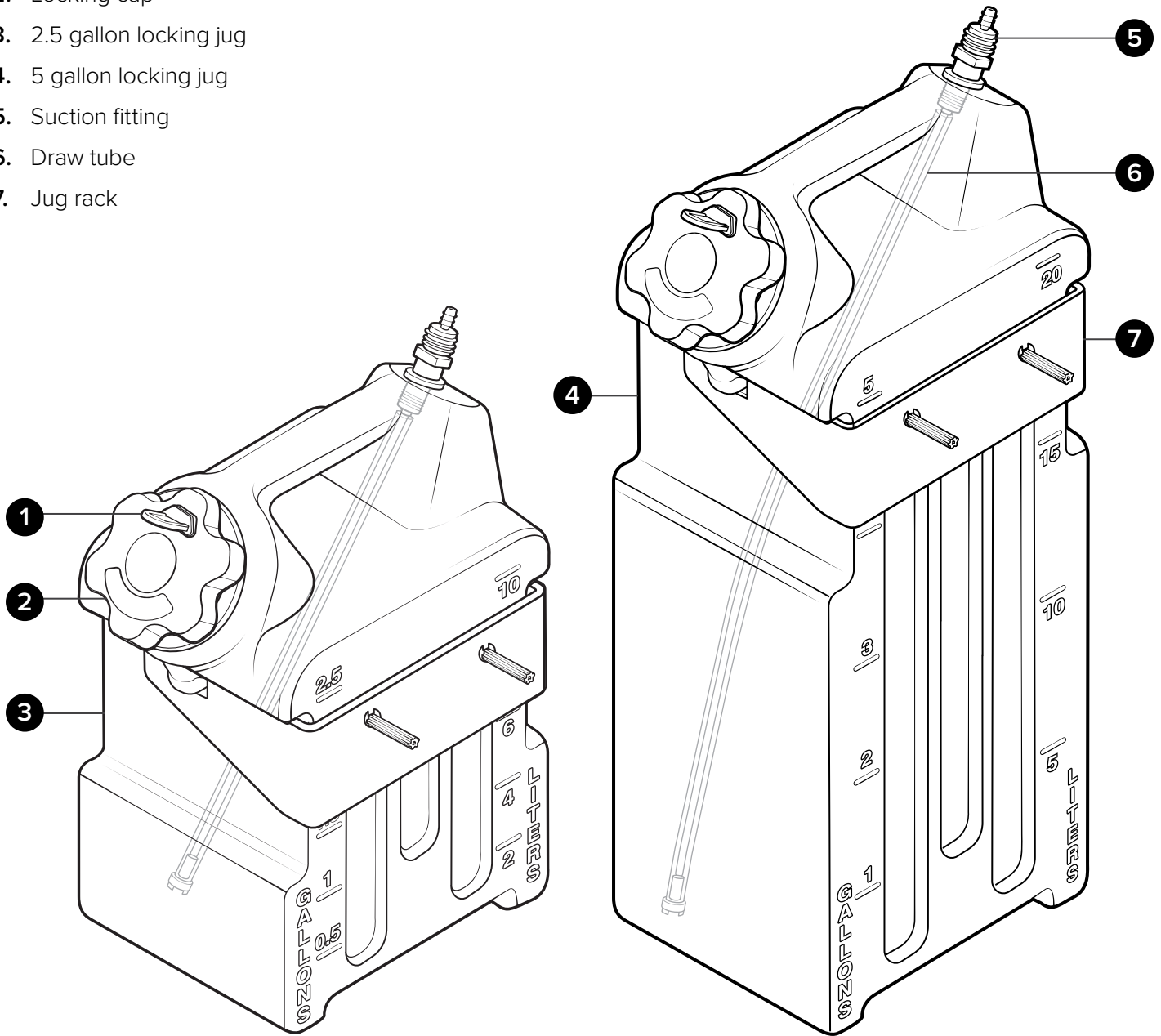

Using your unit

Operating Instructions

1. Following all instructions from the chemical manufacturer, fill the chemical jug with solution.

Note: To remove the cap, the locking key must be fully inserted into the cap assembly.

2. Remove the key from the cap to engage locking feature. With the key *inserted*, the cap can be loosened or tightened. With the key *removed*, the cap will rotate freely but cannot be loosened or tightened.

3. If desired, mount the chemical jug to the wall using the provided mounting hardware and rack.

Note: To drill holes for the plastic anchors, use a $\frac{5}{16}$ in. drill bit.

4. If equipped, connect the suction line to the jug suction fitting.

After Use Instructions

Note: For proper handling and disposal procedures refer to chemical SDS.

5. Before using the unit with another chemistry, thoroughly flush with water.

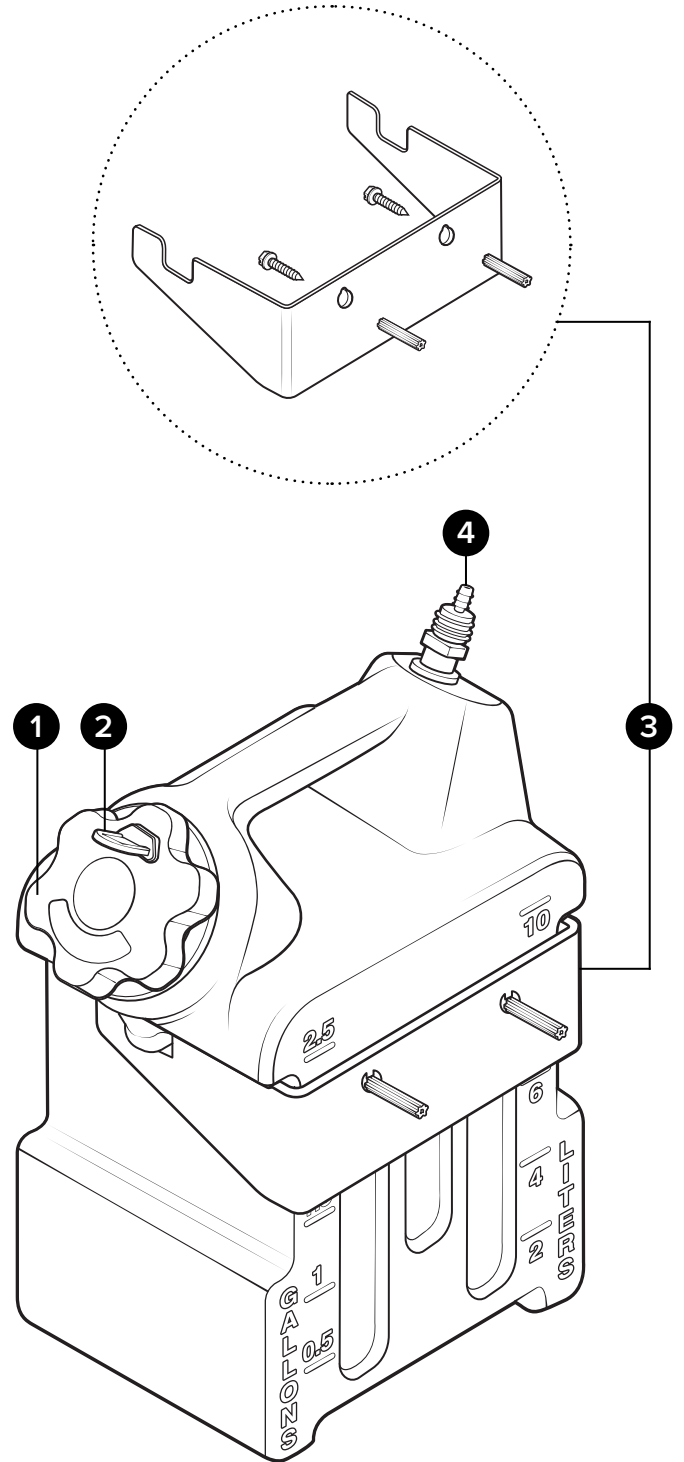

Maintenance

WARNING

Using or servicing the unit without appropriate personal protective equipment (PPE) may result in serious injury such as burns, rashes, eye, throat or lung damage and death. Always wear PPE as indicated in the Safety Data Sheet (SDS) when using or servicing the unit. Servicing or modifying this unit with parts not listed in this manual may cause the unit to operate improperly. Do not use unauthorized parts when servicing the unit.

Maintaining Your Unit

To keep your unit operating properly, periodically perform the following maintenance procedures:

- Inspect the unit for wear and leaks.
- Inspect all hoses for leaks or excessive wear. Make sure all fittings are in good condition and properly secured.
- Check the suction line and strainer for debris. Clean as needed.

Servicing Your Unit

To service your unit, refer to the service manual which includes:

- Troubleshooting procedures.
- Detailed parts breakdowns and illustrations.
- Part numbers of serviceable components and assemblies.



Scan this code for
service manual

