



OPERATION & SERVICE MANUAL



Model: 14-6900-6600
Air Strut Pressure Gauge

09/2023 – Rev. 01

REVISION	DATE	TEXT AFFECTED
OR	04/2005	Original Release
01	09/2023	Major revision



TABLE OF CONTENTS

PAGE

1.0	PRODUCT INFORMATION	1
1.1	MODEL & SERIAL NUMBER.....	1
1.2	MANUFACTURER.....	1
2.0	SAFETY INSTRUCTIONS	1
2.1	GENERAL.....	1
2.2	SAFETY.....	1
3.0	TRAINING	1
3.1	TRAINING REQUIREMENTS	1
3.2	TRAINING PROGRAM	1
3.3	OPERATOR TRAINING.....	1
4.0	OPERATION OF NITROGEN STRUT SERVICE KIT	2
4.1	TRAINING	2
4.2	GENERAL SAFETY REQUIREMENTS	2
5.0	ASSEMBLY INSTRUCTIONS.....	3
5.1	DISASSEMBLY.....	3
6.0	PROVISION OF SPARES.....	4
6.1	SOURCE OF SPARE PARTS.....	4
7.0	IN SERVICE SUPPORT.....	4
8.0	GUARANTEES/LIMITATION OF LIABILITY	4

This product can not be modified without the written approval of Tronair, Inc. Any modifications done without written approval voids all warranties and releases Tronair, Inc., its suppliers, distributors, employees, or financial institutions from any liability from consequences that may occur. Only Tronair OEM replacement parts shall be used.

1.0 PRODUCT INFORMATION

1.1 MODEL & SERIAL NUMBER

Reference nameplate on unit

1.2 MANUFACTURER

TRONAIR, Inc.
1 Air Cargo Pkwy East
Swanton, Ohio 43558 USA

Telephone: (419) 866-6301 or 800-426-6301
Fax: (419) 867-0634
E-mail: sales@tronair.com
Website: www.tronair.com

2.0 SAFETY INSTRUCTIONS



CAUTION!

It is MANDATORY that this instruction manual be read and understood by all persons operating this high pressure Nitrogen strut service kit.

2.1 GENERAL

Information presented in this manual and on various labels, tags and plates on the unit pertains to equipment design, installation, operation, maintenance and troubleshooting which should be read, understood and followed for the safe and effective use of this equipment.

2.2 SAFETY

The operation, maintenance, and trouble shooting of this high pressure Nitrogen strut service kit requires practices and procedures which ensure personal operator safety and the safety of others. Therefore, this equipment is to be operated and maintained only by qualified persons in accordance with this manual and all applicable local codes.

NOTE: Safety instructions specifically pertaining to this kit appear throughout this manual highlighted by the signal words: WARNING, CAUTION, which identify different levels of hazard.



WARNING! Denote practices which if not carefully followed, could result in *serious personal injury and/or death*.

CAUTION! Denote practices which if not carefully followed, could result in *minor personal injury or damage to this equipment*.

Nitrogen equipment must be kept clean and free from contaminants at all times. It is imperative that all inspection, maintenance, testing and servicing of Nitrogen system components be done by trained and qualified personnel using approved procedures.

3.0 TRAINING

3.1 TRAINING REQUIREMENTS

The employer of the operator is responsible for providing a training program sufficient for the safe operation of the unit.

3.2 TRAINING PROGRAM

The employer provided operator training program should cover safety procedures concerning use of the unit in and around the intended aircraft at the intended aircraft servicing location.

3.3 OPERATOR TRAINING

The operator training should provide the required training for safe operation of the unit.

NOTE: Maintenance and Trouble Shooting are to be performed by a skilled and trained technician.

4.0 OPERATION OF NITROGEN STRUT SERVICE KIT



WARNING!

TO AVOID SERIOUS INJURY, LOSS OF LIMB, AND/OR DEATH:

1. **DO NOT** use high pressure Nitrogen on aircraft components designed for low pressure Nitrogen.
2. **DO NOT** use with oxygen or gas other than Nitrogen.
3. **DO NOT** exceed 600 psi inlet pressure.
4. Servicing and maintenance of Nitrogen systems shall be done by only trained and qualified personnel using approved procedures.

4.1 TRAINING

Read this entire manual prior to operation of the unit. All personnel using this Nitrogen Service Strut Kit should understand and follow this manual and receive training. We encourage our customers to call Tronair at 800-426-6301 to discuss any operating or testing requirements.

4.2 GENERAL SAFETY REQUIREMENTS

Pressures: Gasses under pressure are a potential hazard in the form of stored energy. Accidents can occur when this energy is improperly handled. Be sure that all equipment used is compatible and designed to control the pressures encountered.

Nitrogen: Nitrogen is chemically stable, non-flammable, and does not support combustion.

Handling: Nitrogen handling must be done with care. The rapid expansion of Nitrogen gas from a high pressure source to an area of low pressure can produce cryogenic temperatures which could cause severe burns.



WARNING!

1. **DO NOT** use on low pressure Nitrogen system or components.
2. If there are any differences between the following instructions and the aircraft maintenance manual, the aircraft maintenance manual will take precedence.
3. Be sure fill line is secured prior to purging the unit. This will prevent the nose end from whipping about if too much Nitrogen is allowed to flow through the unit.



CAUTION!

Be sure all valves and controls are in the closed (OFF) position.

5.0 ASSEMBLY INSTRUCTIONS

NOTE: It is recommended Nitrogen servicing procedure should be accomplished in conjunction with Tronair Service Regulator/Model: 14-6804-6000.

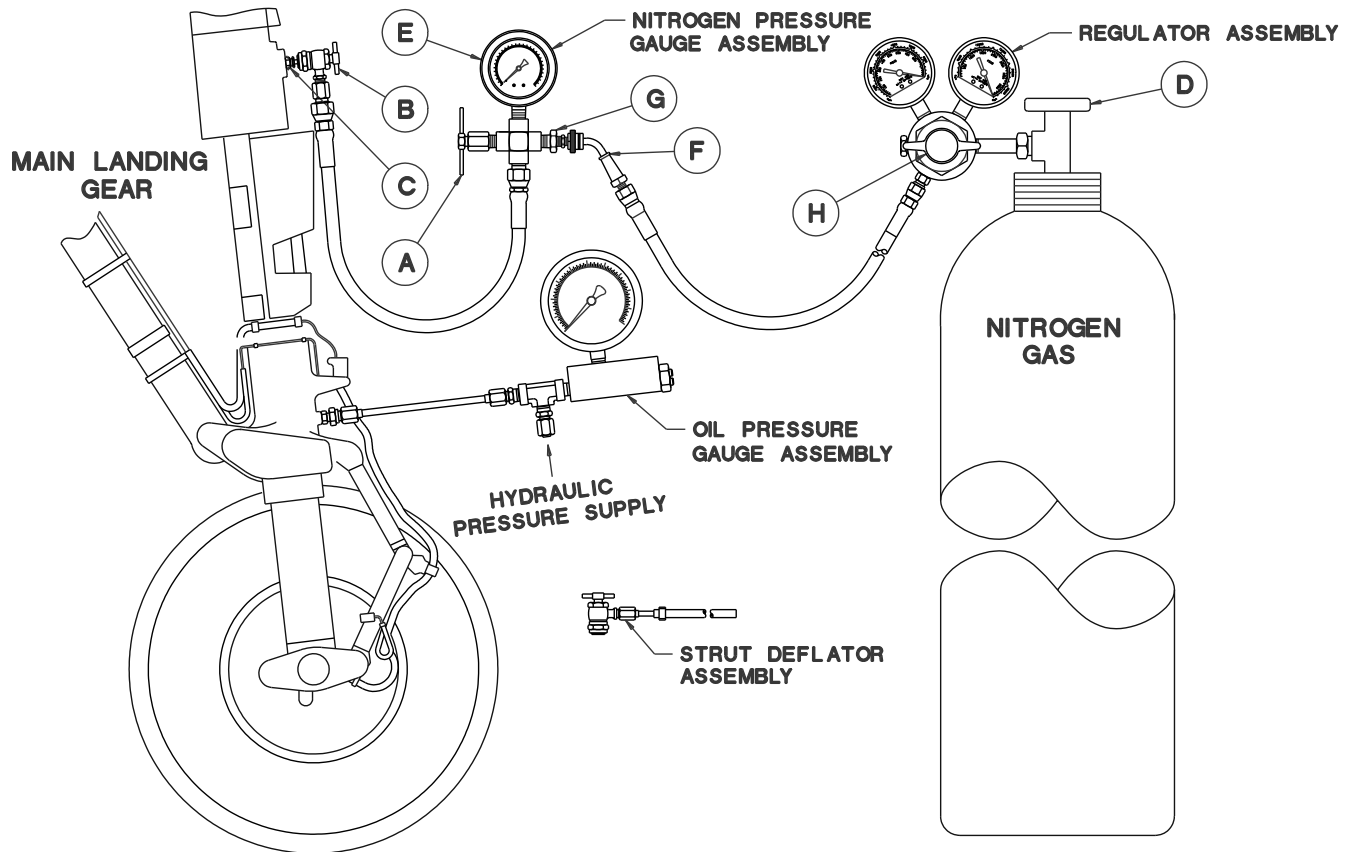
**FIGURE 1**

Reference **Figure 1** during the following steps:

1. Ensure (D) Nitrogen Supply Valve is closed (OFF).
2. Connect (H) Pressure Regulator to Nitrogen supply (not included) if not already connected.
3. Decrease (H) Pressure Regulator to the minimum pressure setting; the regulator adjustment knob is a rotating type. Clockwise rotation of the knob increases pressure and counter-clockwise rotation decreases pressure.
4. Turn valve handle clockwise to close (A) Air Bleeder Valve.
5. Connect (F) Hose Coupling to (G) Pressure Valve.
6. Ensure (C) Nitrogen Charging Valve is in closed position. (Refer to Aircraft Maintenance Manual)
7. Connect (B) Hose Coupling to (C) Nitrogen Charging Valve.
8. Open (C) Nitrogen Charging Valve. (Refer to Aircraft Maintenance Manual)
9. Turn handle clockwise on (B) Hose Coupling to depress valve core in (C) Nitrogen Charging Valve.
10. Open (D) Nitrogen Supply Valve.
11. Adjust (H) Pressure Regulator until (E) Pressure Gauge reads desired pressure.

5.1 DISASSEMBLY

Reference **Figure 12** during the following steps:

1. Close (C) Nitrogen Charging Valve. (Refer to Aircraft Maintenance Manual)
2. Turn handle counter-clockwise on (B) Hose Coupling to release valve core in (C) Nitrogen Charging Valve.
3. Close (D) Nitrogen Supply Valve (OFF).
4. Bleed off any excess Nitrogen in gauges and lines by turning valve handle counter-clockwise to open (A) Air Breeder Valve.
5. Disconnect Pressure Gauge Assembly from strut and Regulator Assembly.



6.0 PROVISION OF SPARES

6.1 SOURCE OF SPARE PARTS

Spare parts may be obtained from the manufacturer:

TRONAIR, Inc.

1 Air Cargo Pkwy East

Swanton, Ohio 43558 USA

Telephone: (419) 866-6301 or 800-426-6301

Fax: (419) 867-0634

E-mail: sales@tronair.com

Website: www.tronair.com



For Spare Parts, Operations & Service Manuals or Service Needs:

Scan the QR code or visit Tronair.com/aftermarket

7.0 IN SERVICE SUPPORT

Contact Tronair, Inc. for technical services and information. See Section 1.3 – Manufacturer.

8.0 GUARANTEES/LIMITATION OF LIABILITY

Tronair products are warranted to be free of manufacturing or material defects for a period of one year after shipment to the original customer. This is solely limited to the repair or replacement of defective components. This warranty does not cover the following items:

- a) Parts required for normal maintenance
- b) Parts covered by a component manufacturers warranty
- c) Replacement parts have a 90-day warranty from date of shipment

If you have a problem that may require service, contact Tronair immediately. Do not attempt to repair or disassemble a product without first contacting Tronair, any action may affect warranty coverage. When you contact Tronair be prepared to provide the following information:

- a) Product Model Number
- b) Product Serial Number
- c) Description of the problem

If warranty coverage is approved, either replacement parts will be sent or the product will have to be returned to Tronair for repairs. If the product is to be returned, a Return Material Authorization (RMA) number will be issued for reference purposes on any shipping documents. Failure to obtain a RMA in advance of returning an item will result in a service fee. A decision on the extent of warranty coverage on returned products is reserved pending inspection at Tronair. Any shipments to Tronair must be shipped freight prepaid. Freight costs on shipments to customers will be paid by Tronair on any warranty claims only. Any unauthorized modification of the Tronair products or use of the Tronair products in violation of cautions and warnings in any manual (including updates) or safety bulletins published or delivered by Tronair will immediately void any warranty, express or implied.

The obligations of Tronair expressly stated herein are in lieu of all other warranties or conditions expressed or implied. **Any unauthorized modification of the Tronair products or use of the Tronair products in violations of cautions and warnings in any manual (including updates) or safety bulletins published or delivered by Tronair will immediately void any warranty, express or implied and Tronair disclaims any and all liability for injury (WITHOUT LIMITATION and including DEATH), loss or damage arising from or relating to such misuse.**

Parts List



WARNING!

The maximum operating pressure for this gauge assembly is 3000 psi.

GAUGE CALIBRATION: The pressure gauge is to be calibrated annually or as required. See Appendix I.

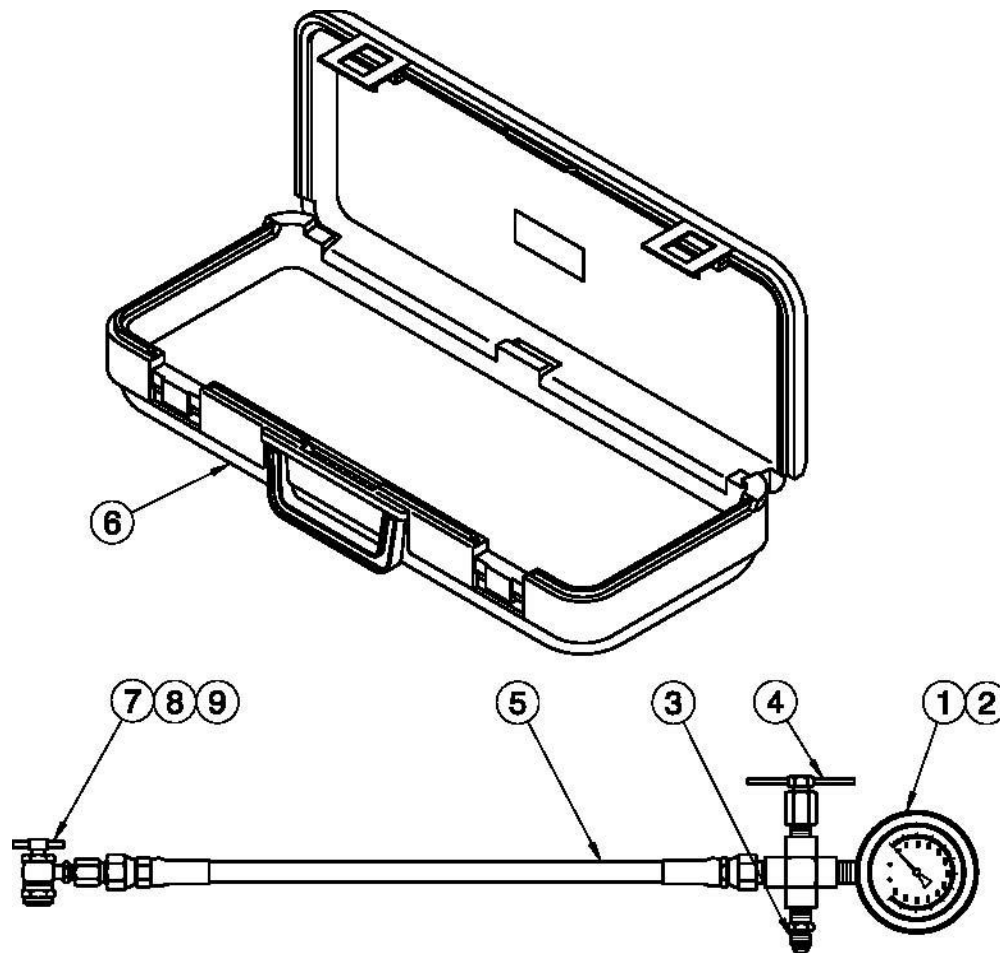

Item	Part Number	Description	Qty
1	HC-1868	Gauge, 600 psi Pressure (Calibrated)	1
2	H-2153	Boot, Gauge	1
3	N-2009-04-S	Connector, Male	1
4	Z-3828	Assembly, Air Bleed Valve	1
5	TF-1043-15*16.0	Hose, 16 inch long	1
6	Z-3830-03	Assembly, Replacement Box	1
7	PC-1007	Connector, High Pressure	1
8	HC-2006-008	O Ring, Series 2	1
9	HC-2006-013	O Ring, Series 2	1

Instrument Certification Notice

The gauge Certificates of Calibration supplied for the gauge(s) on this unit contain the calibration data for the actual instrument calibrated, along with the calibration date of the **STANDARD** used to perform the calibration check.

The due date for re-calibration of the instrument should be based upon the date the instrument was placed in service in your facility. Re-calibration should be done on a periodic basis as dictated by the end user's quality system or other overriding requirements.

Note that Tronair, Inc. does not supply certificates of calibration on flow meters or pyrometers unless requested at the time of placed order. These instruments are considered reference indicators only and are not critical to the test(s) being performed on the aircraft.