

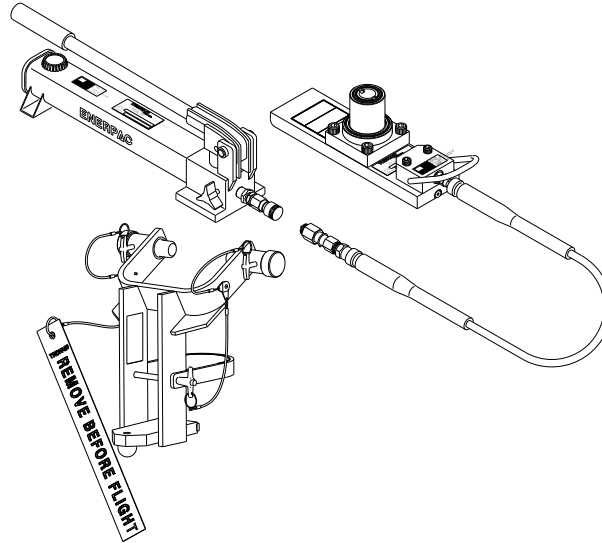

# OPERATION & SERVICE MANUAL



**Model: 02-7862C0100**  
**12 Ton Axle Jack**



08/2024 - Rev. 02

The Tronair Group of Companies: Tronair | EBIS | Columbus Jack | Eagle | DAE | Malabar International

**Tronair, Inc.**  
1 Air Cargo Pkwy East  
Swanton, OH 43558

Phone: (419) 866-6301 | 800-426-6301  
Web: [www.tronair.com](http://www.tronair.com)  
Email: [sales@tronair.com](mailto:sales@tronair.com)

| REVISION | DATE    | TEXT AFFECTED\   |
|----------|---------|------------------|
| 01       | 05/2008 | Original Release |
| 02       | 08/2024 | Major revision   |



**TABLE OF CONTENTS**

**PAGE**

|             |   |          |
|-------------|---|----------|
| <b>1.0</b>  | <b>PRODUCT INFORMATION .....</b>                | <b>1</b> |
| 1.1         | DESCRIPTION.....                                | 1        |
| 1.2         | MODEL & SERIAL NUMBER.....                      | 1        |
| 1.3         | MANUFACTURER.....                               | 1        |
| 1.4         | SPECIFICATIONS .....                            | 1        |
| <b>2.0</b>  | <b>SAFETY INFORMATION.....</b>                  | <b>2</b> |
| 2.1         | USAGE AND SAFETY INFORMATION .....              | 2        |
| <b>3.0</b>  | <b>TRAINING.....</b>                            | <b>2</b> |
| 3.1         | TRAINING REQUIREMENTS .....                     | 2        |
| 3.2         | TRAINING PROGRAM .....                          | 2        |
| 3.3         | OPERATOR TRAINING.....                          | 2        |
| <b>4.0</b>  | <b>ASSEMBLY INSTRUCTIONS.....</b>               | <b>2</b> |
| 4.1         | GENERAL INFORMATION.....                        | 2        |
| 4.2         | PRE-USE CHECKS .....                            | 2        |
| <b>5.0</b>  | <b>OPERATING INSTRUCTIONS .....</b>             | <b>3</b> |
| 5.1         | TO RAISE NOSE GEAR .....                        | 3        |
| 5.1.1       | To Lower Nose Gear.....                         | 3        |
| 5.2         | TO RAISE MAIN GEAR .....                        | 3        |
| 5.2.1       | To Lower Main Gear .....                        | 3        |
| <b>6.0</b>  | <b>TROUBLE SHOOTING.....</b>                    | <b>4</b> |
| <b>7.0</b>  | <b>MAINTENANCE.....</b>                         | <b>4</b> |
| 7.1         | SERVICING JACK .....                            | 4        |
| 7.1.1       | To Disassemble Jack.....                        | 4        |
| 7.1.2       | To Re-Assemble Jack.....                        | 4        |
| 7.1.3       | To Bleed Jack For Air.....                      | 4        |
| 7.2         | JACK FUNCTION LOAD TEST.....                    | 4        |
| <b>8.0</b>  | <b>PROVISION OF SPARES.....</b>                 | <b>5</b> |
| 8.1         | SOURCE OF SPARE PARTS.....                      | 5        |
| 8.2         | RECOMMENDED SPARE PARTS LISTS .....             | 5        |
| <b>9.0</b>  | <b>GUARANTEES/LIMITATION OF LIABILITY .....</b> | <b>5</b> |
| <b>10.0</b> | <b>APPENDICES .....</b>                         | <b>5</b> |

This product can not be modified without the written approval of Tronair, Inc. Any modifications done without written approval voids all warranties and releases Tronair, Inc., its suppliers, distributors, employees, or financial institutions from any liability from consequences that may occur. Only Tronair OEM replacement parts shall be used.

**1.0 PRODUCT INFORMATION**

**1.1 DESCRIPTION**

The purpose of this jack is to lift aircraft at the landing gear for maintenance. It has a maximum capacity of 12 tons (10.9 metric tons).

The Tronair Model 02-7862C0100 Hydraulic Axle Jack incorporates the following quality features:

- Steel construction
- Three-stage hydraulic ram
- High/Low manually operated pump
- Uses standard MIL-PRF-5606 Hydraulic Fluid
- The jack is specifically designed for use on Cessna Sovereign 680 Aircraft; included is a NLG jacking adapter.
- Mechanical extension to increase closed height to 2 1/4in.

**1.2 MODEL & SERIAL NUMBER**

Reference nameplate on unit

**1.3 MANUFACTURER**

**TRONAIR, Inc.**  
1 Air Cargo Pkwy East  
Swanton, Ohio 43558 USA

Telephone: (419) 866-6301 or 800-426-6301  
Fax: (419) 867-0634  
E-mail: sales@tronair.com  
Website: www.tronair.com

**1.4 SPECIFICATIONS**

(Reference Figure 1)

|                                 |  |
|---------------------------------|--|
| Vertical capacity .....         | 24,000 lbs (10,884 kg)                       |
| Minimum closed height.....      | 5.1 in (12.95 cm)                            |
| Hydraulic extension.....        | 5.8 in (14.73 cm)                            |
| Mechanical extension.....       | 2.3 in (5.84 cm)                             |
| Maximum height obtainable ..... | 13.2 in (33.53 cm) with mechanical extension |
| Weight.....                     | 55 lbs (24.95 kg)                            |

BUNA 'N' Seals

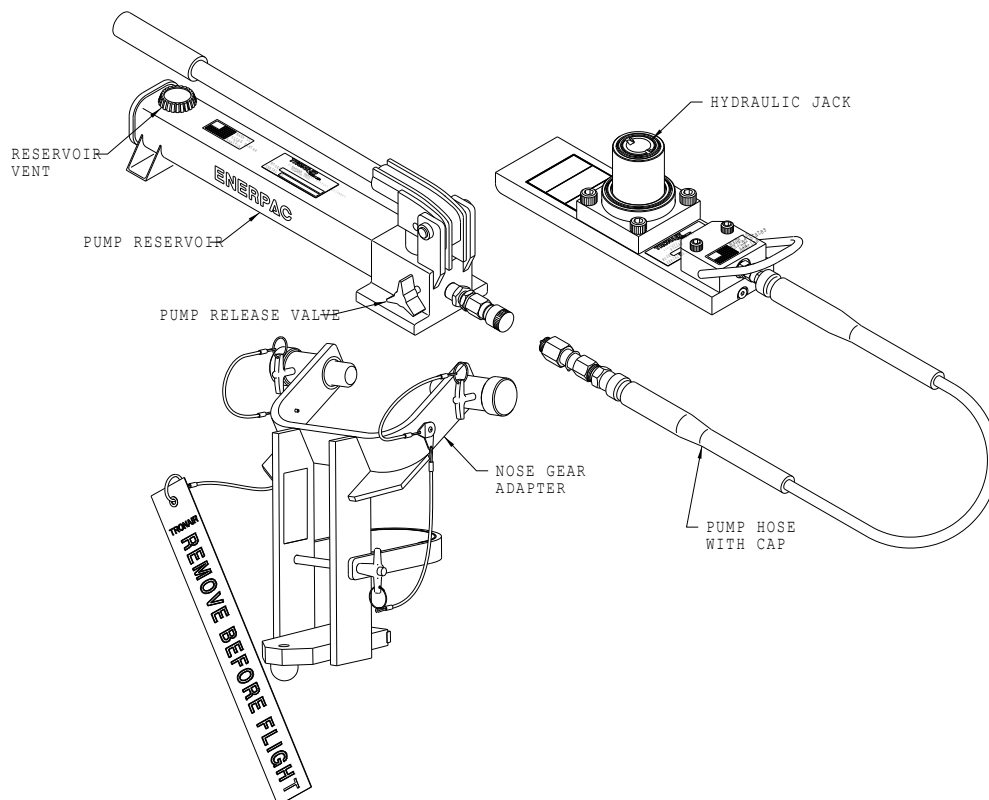

**FIGURE 1**

## 2.0 SAFETY INFORMATION

### 2.1 USAGE AND SAFETY INFORMATION

To ensure safe operations please read the following statements and understand their meaning. Also refer to your equipment manufacturer's manual for other important safety information. This manual contains safety precautions which are explained below. Please read carefully.



#### **WARNING!**

Warning is used to indicate the presence of a hazard that can cause **severe personal injury, death, and/or substantial property damage** if the Warning Notice is ignored.



#### **CAUTION!**

Caution is used to indicate the presence of a hazard, which will or can cause **minor personal injury or property damage** if the Caution Notice is ignored.

## 3.0 TRAINING

### 3.1 TRAINING REQUIREMENTS

The employer of the operator is responsible for providing a training program sufficient for the safe operation of the unit.

### 3.2 TRAINING PROGRAM

The employer provided operator training program should cover safety procedures concerning use of the unit in and around the intended aircraft at the intended aircraft servicing location.

### 3.3 OPERATOR TRAINING

The operator training should provide the required training for safe operation of the unit.

**NOTE: Maintenance and Trouble Shooting are to be performed by a skilled and trained technician.**

## 4.0 ASSEMBLY INSTRUCTIONS

### 4.1 GENERAL INFORMATION

This product should be assembled and/or repaired using good workmanship practices and proper tools.

All replacement parts must be the same as or equal to the original parts supplied.

### 4.2 PRE-USE CHECKS

Refer to the Parts Lists and Illustrations to identify and ensure that all parts are present.

Generally, check over unit to ensure the tightness of all nuts, bolts and screws. With rams completely collapsed, check to see if the hydraulic pump reservoir is filled with hydraulic fluid. Replenish with MIL-PRF-5606 fluid as required.

**5.0 OPERATING INSTRUCTIONS**

The user should be familiar with the following statements prior to using the jack(s).

**CAUTION!**

**NEVER** put hands between aircraft and jack pad.  
**ALWAYS** open reservoir vent screw before operating.

**5.1 TO RAISE NOSE GEAR**

(Reference Figure 2)

1. Attach the nose gear adapter to the strut. Place the strap around the strut and lock in place with the ball lok-T pin. Insert both sliding pins into the towing bowls on the strut. Lock sliding pins in place with the ball lok-T pins.
2. Place hydraulic jack on a hard level surface.
3. Use the mechanical extension in order to get the cylinder assembly as close as possible to the nose gear adapter.
4. After the nose gear adapter is secured onto the strut, line up jack pad with the spherical recess in the center of the cylinder assembly.
5. Chock aircraft tires on gear not being raised.
6. Connect pump hose.
7. Open reservoir vent screw.
8. Close pump release valve and operate pump.

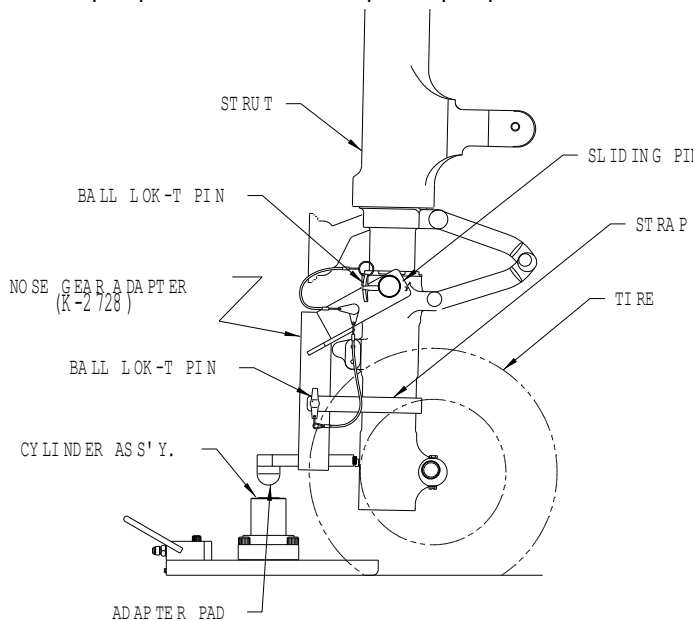

**Figure 2**

**5.1.1 To Lower Nose Gear**

Slightly open pump release valve to slowly lower nose gear.

**5.2 TO RAISE MAIN GEAR**

1. Place hydraulic jack on a hard level surface between tires.
2. Use the mechanical extension in order to get the cylinder assembly as close as possible to the jack pad.
3. Line up jack pad with the spherical recess in the center of the cylinder assembly.
4. Chock aircraft tires on gear not being raised.
5. Connect pump hose.
6. Open reservoir vent screw.
7. Close pump release valve and operate pump.

**5.2.1 To Lower Main Gear**

Slightly open pump release valve to slowly lower main gear.

## 6.0 TROUBLE SHOOTING

| PROBABLE CAUSE                                  | CORRECTIVE ACTION   |
|---|---|
| RAM WILL NOT RISE OR RISES ERRATICALLY          |   |
| High pressure leaks (at joint, plugs or tubing) | Re-tighten or repair  |
| Leaky discharge check valve                     | Open release valve, pump rapidly to dislodge;<br>Or repair pump |
| Leaky ram O-ring packing                        | Replace packing   |
| Leaky release valve                             | Tighten release valve   |
| Leaky pump O-ring packing                       | Repair pump   |
| Lack of oil                                     | Refill reservoir check system for leaks                         |
| Sticking inlet check valve                      | Open release valve, pump rapidly to dislodge;<br>Or repair pump |
| Closed air vent                                 | Open air vent   |
| Air under ram                                   | Bleed system  |
| JACK WILL NOT LOWER                             |   |
| Closed air vent or release valve                | Open air vent or release valve                                  |
| Broken pump release valve                       | Replace release valve   |
| Bent ram  | Replace suspected ram assembly                                  |

## 7.0 MAINTENANCE

### GENERAL

- All maintenance and/or repair work should be done using good workmanship practices and proper tools.
- The work area should be clean and free of dirt.
- When O-rings and backup rings are removed, every effort should be made to avoid the contact of tools with the critical surfaces of parts. Surface deformities could cause degradation of seals and failure.
- It is good practice to replace all O-rings and backup rings once removed. Cut and damaged rings normally result in fluid leakage.
- At this time flush old hydraulic fluid and dirt from overall system and replenish with new, clean hydraulic fluid.
- No modifications shall be carried out without prior written approval by Tronair.

### 7.1 SERVICING JACK

#### 7.1.1 To Disassemble Jack

1. Collapse jack rams.
2. Remove cap screws (Item 3) surrounding jack cylinder and retaining ring (Item 2).
3. Lift cylinder from axle jack base weldment (Item 1). Operate jack hand pump to help remove cylinder.
  - Separate rams by removing internal rings (Items 4 and 5).
  - Replace all seals including internal rings.

#### 7.1.2 To Re-Assemble Jack

1. Re-assemble in reverse order of above.
2. Torque each cap screw (Item 3) to 50 ft-lb, using standard cross torque procedure.

#### 7.1.3 To Bleed Jack For Air

1. Open reservoir vent screw on hand pump.
2. Pump unit to fully extended position.
3. Turn jack upside down.
4. Push jack back to fully collapsed position.

### 7.2 JACK FUNCTION LOAD TEST

1. Take all necessary precautions to prevent injury.
2. Always jack against a load and **never against the jack itself**.
3. Apply a test load equal to the jack rated capacity plus 10%. **Do not exceed this load.**
4. Test annually.



## 8.0 PROVISION OF SPARES

### 8.1 SOURCE OF SPARE PARTS

Spare parts may be obtained from the manufacturer:

|                         |   |
|-------------------------|---|
| <b>TRONAIR</b> , Inc.   | Telephone: (419) 866-6301 or 800-426-6301 |
| 1 Air Cargo Pkwy East   | Fax: (419) 867-0634                       |
| Swanton, Ohio 43558 USA | E-mail: sales@tronair.com                 |
|                         | Website: www.tronair.com                  |



For Spare Parts, Operations & Service Manuals or Service Needs:  
Scan the QR code or visit [Tronair.com/aftermarket](http://Tronair.com/aftermarket)

### 8.2 RECOMMENDED SPARE PARTS LISTS

Reference the following page(s) for Replacement Parts and Kits available.

Recommended Spares:

|                  |                                     |
|------------------|-------------------------------------|
| K-1308.....      | Ball Loc Pin Replacement Kit        |
| K-1508.....      | Hydraulic Pump Seal Replacement Kit |
| K-3772.....      | Hand Pump w/Labels Kit              |
| K-2606.....      | Cylinder Seal Replacement Kit       |
| HC-2008-109..... | O-ring, Series 2                    |
| HC-2000-012..... | O-ring, Series 2                    |

## 9.0 GUARANTEES/LIMITATION OF LIABILITY

Tronair products are warranted to be free of manufacturing or material defects for a period of one year after shipment to the original customer. This is solely limited to the repair or replacement of defective components. This warranty does not cover the following items:

- Parts required for normal maintenance
- Parts covered by a component manufacturers warranty
- Replacement parts have a 90-day warranty from date of shipment

If you have a problem that may require service, contact Tronair immediately. Do not attempt to repair or disassemble a product without first contacting Tronair, any action may affect warranty coverage. When you contact Tronair be prepared to provide the following information:

- Product Model Number
- Product Serial Number
- Description of the problem

If warranty coverage is approved, either replacement parts will be sent or the product will have to be returned to Tronair for repairs. If the product is to be returned, a Return Material Authorization (RMA) number will be issued for reference purposes on any shipping documents. Failure to obtain a RMA in advance of returning an item will result in a service fee. A decision on the extent of warranty coverage on returned products is reserved pending inspection at Tronair. Any shipments to Tronair must be shipped freight prepaid. Freight costs on shipments to customers will be paid by Tronair on any warranty claims only. Any unauthorized modification of the Tronair products or use of the Tronair products in violation of cautions and warnings in any manual (including updates) or safety bulletins published or delivered by Tronair will immediately void any warranty, express or implied.

The obligations of Tronair expressly stated herein are in lieu of all other warranties or conditions expressed or implied. **Any unauthorized modification of the Tronair products or use of the Tronair products in violations of cautions and warnings in any manual (including updates) or safety bulletins published or delivered by Tronair will immediately void any warranty, express or implied and Tronair disclaims any and all liability for injury (WITHOUT LIMITATION and including DEATH), loss or damage arising from or relating to such misuse.**

## 10.0 APPENDICES

|              |                                    |
|--------------|------------------------------------|
| APPENDIX I   | Enerpac Instruction & Repair Parts |
| APPENDIX II  | SDS (MIL-PRF-5606 Hydraulic Fluid) |
| APPENDIX III | Declaration Of Conformity          |
| APPENDIX IV  | Maintenance Schedule               |

### Parts List

When ordering replacement parts/kits, please specify model, serial number and color of your unit.

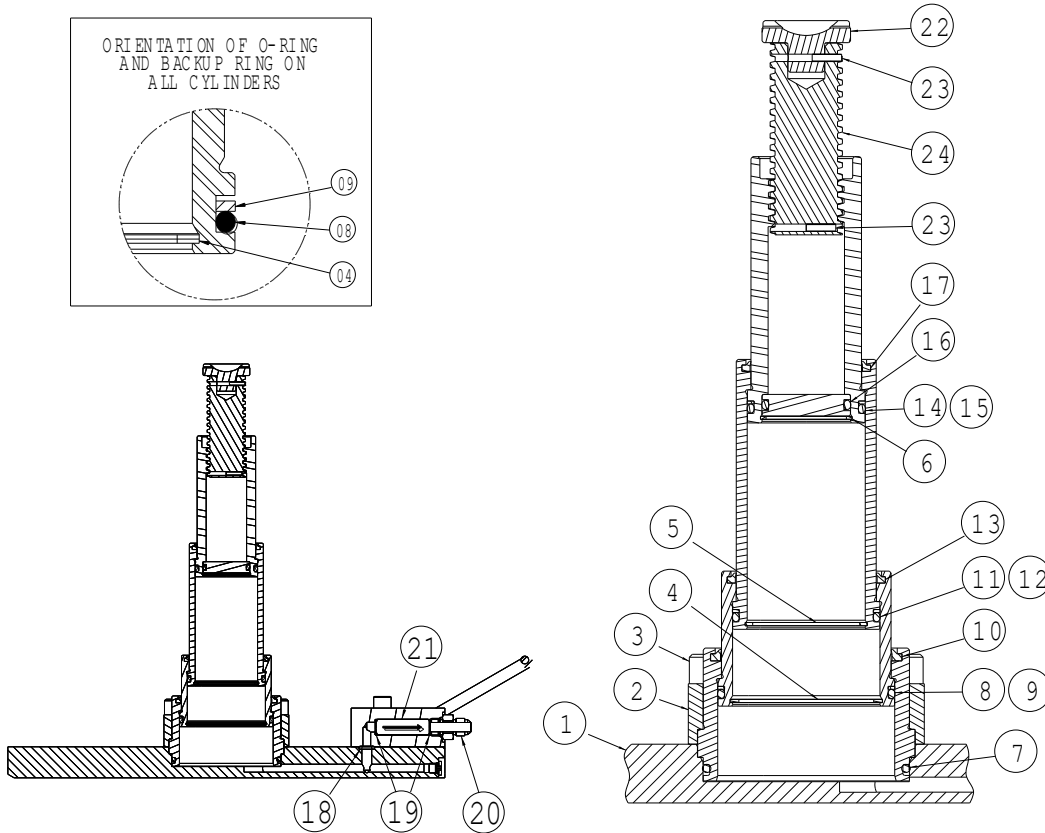

| Item | Part Number   | Description                                    | Qty |
|------|---------------|--|-----|
| 1    | J-3548-01     | Plate Base                                     | 1   |
| 2    | J-3549        | Ring, Cylinder Retaining                       | 1   |
| 3    | G-1151-109716 | Screw, Socket Head Cap, 1/2 - 20 x 1 3/4" long | 4   |
| 4    | G-1398-250    | First Cylinder Internal Ring                   | 1   |
| 5    | G-1398-200    | Second Cylinder Internal Ring                  | 1   |
| 6    | G-1398-150    | Third Cylinder Internal Ring                   | 1   |
| 7    | HC-2008-236   | Main Cylinder O-ring                           | 1   |
| 8    | HC-2000-232   | First Cylinder O-ring                          | 1   |
| 9    | HC-2023-232   | First Cylinder Backup Ring                     | 1   |
| 10   | HC-1697-28    | Main Cylinder Wiper                            | 1   |
| 11   | HC-2000-228   | Second Cylinder O-ring                         | 1   |
| 12   | HC-2023-228   | Second Cylinder Backup Ring                    | 1   |
| 13   | HC-1697-24    | First Cylinder Wiper                           | 1   |
| 14   | HC-2000-224   | Third Cylinder O-ring                          | 1   |
| 15   | HC-2023-224   | Third Cylinder Backup Ring                     | 1   |
| 16   | HC-2000-218   | O-Ring   | 1   |
| 17   | HC-1697-20    | Second Cylinder Wiper                          | 1   |
| 18   | HC-2008-109   | O-Ring   | 1   |
| 19   | HC-2000-012   | O-Ring   | 2   |
| 20   | N-2007-08-S-B | Connector, SAE #6                              | 1   |
| 21   | HC-1969       | Velocity Fuse                                  | 1   |
| 22   | R-2131        | Jack Pad                                       | 1   |
| 23   | G-1300-13040  | Pin, Roll                                      | 2   |
| 24   | R-1628-03     | Mechanical Extension                           | 1   |

### Parts List

When ordering replacement parts/kits, please specify model, serial number and color of your unit.

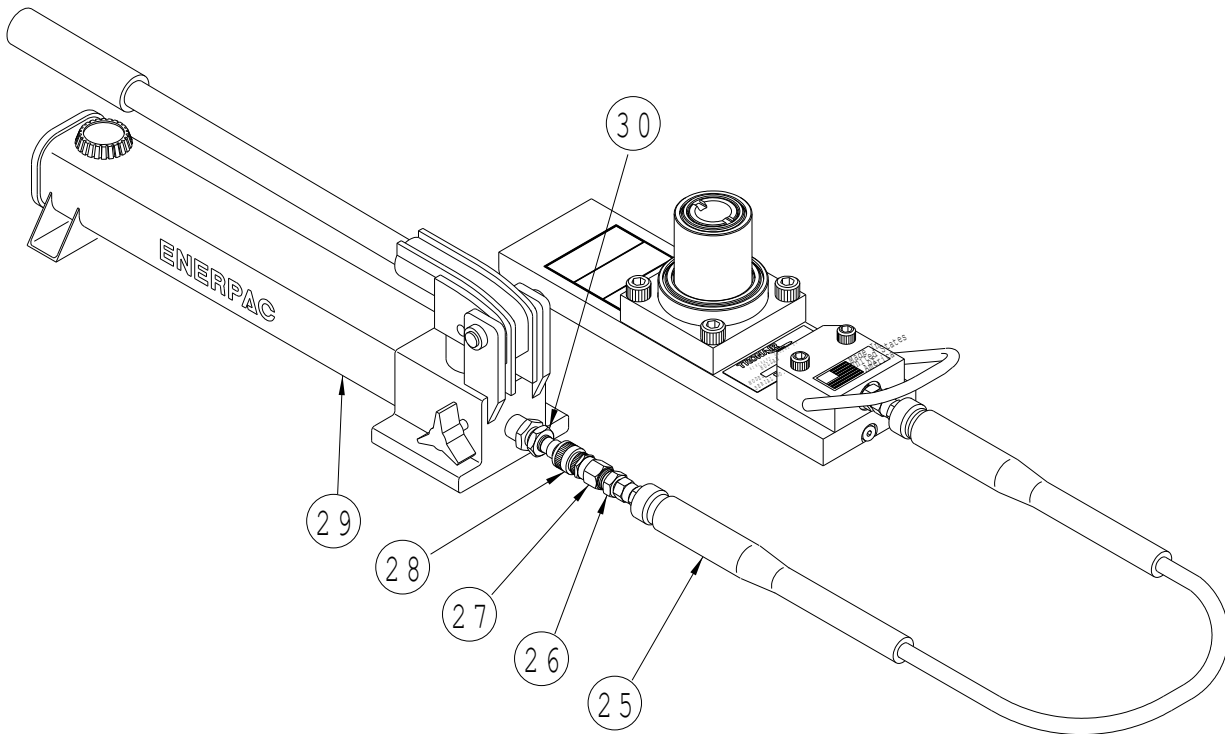

| Item | Part Number                           | Description  | Qty |
|------|---------------------------------------|--|-----|
| 30   | N-2203-06-S                           | Nipple, Pipe   | 1   |
| 25   | TF-1104-01*31.0                       | Assembly, Hose (#4 Mineral Base)   | 1   |
| 26   | N-2009-08-S                           | Connector, Male  | 1   |
| 27   | N-2712                                | Coupler, Hydraulic (Female)  | 1   |
| 28   | N-2713                                | Nipple, Hydraulic (Male)   | 1   |
| 29   | <i>Reference K-3772 Hand Pump Kit</i> |  |     |
|      | <b>K-3772</b>                         | <b>Kit, Replacement Hand Pump; consists of:</b>  |     |
| 30   | N-2203-06-S                           | Nipple, Pipe   | 1   |
| 28   | N-2713                                | Nipple, Hydraulic (Male)   | 1   |
| 29   | H-1595-09                             | Hand Pump with Labels  | 1   |
| N/S  | <b>K-1508</b>                         | <b>Kit, Hydraulic Hand Pump Seal</b><br><i>(This kit includes all soft seals, wipers, and gaskets required to reseal the pump)</i> |     |

### Parts List

When ordering replacement parts/kits, please specify model, serial number and color of your unit.

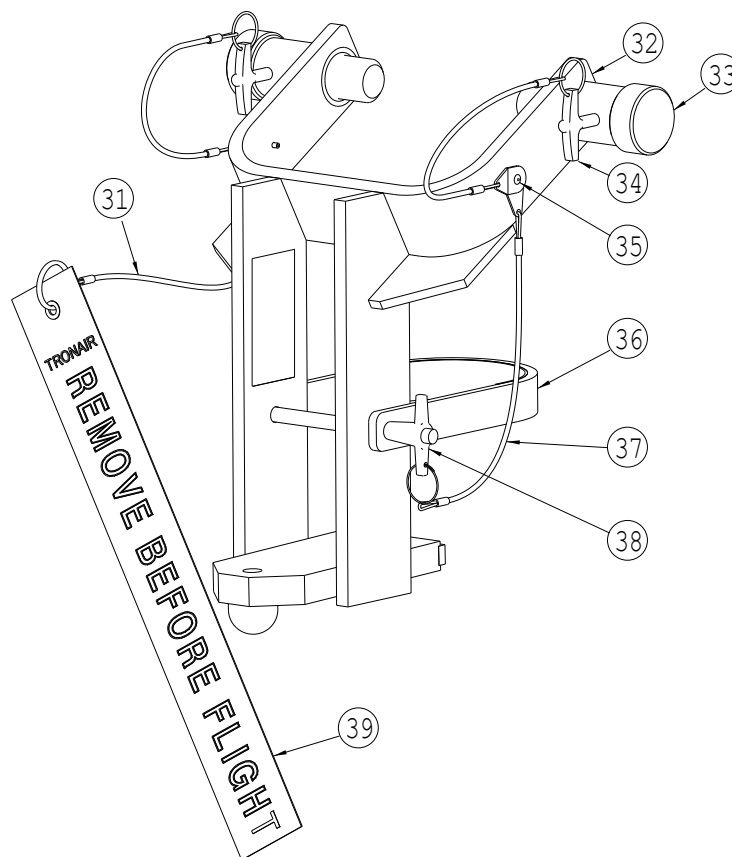

| Item | Part Number                                       | Description  | Qty |
|------|---|--|-----|
| 31   | H-1026*07.0                                       | Assembly, Lanyard                                    | 1   |
| 32   | <i>Reference K-2728 Nose Adapter Assembly Kit</i> |  |     |
| 33   | R-1671  | Pin, Sliding   | 1   |
| 34   | G-1310-0415                                       | Pin, Ball Lok-T, 1/4" diameter x 1.5" Grip           | 1   |
| 35   | G-1351-04   | Rivet, 1/8" Open-end Steel                           | 1   |
| 36   | Z-3369  | Assembly, Nose Adapter Strap                         | 1   |
| 37   | H-1026*12.0                                       | Assembly, Lanyard                                    | 1   |
| 38   | G-1310-0645                                       | Pin, Ball Lok-T, 3/8" x 4.5" Grip                    | 1   |
| N/S  | G-1300-19040                                      | Pin, Roll, 3/16" diameter x 1/2" long                | 1   |
|      | <b>K-1308</b>                                     | <b>Kit, Replacement Ball Lok-T Pin; consists of:</b> |     |
| 31   | H-1026*07.0                                       | Assembly, Lanyard                                    | 1   |
| 34   | G-1310-0415                                       | Pin, Ball Lok-T, 1/4" diameter x 1.5" grip           | 1   |
| 35   | G-1351-04   | Rivet, 1/8" Open-end Steel                           | 1   |
|      | <b>K-2728</b>                                     | <b>Kit, Nose Adapter Assembly; consists of:</b>      |     |
| 31   | H-1026*07.0                                       | Assembly, Lanyard                                    | 3   |
| 32   | Z-3367-01   | Weldment, Nose Adapter Bracket with Labels           | 1   |
| 33   | R-1671  | Pin, Sliding   | 2   |
| 34   | G-1310-0415                                       | Pin, Ball Lok-T, 1/4" x 1.5" Grip                    | 2   |
| 35   | G-1351-04   | Rivet  | 2   |
| 36   | Z-3369  | Assembly, Nose Adapter Strap                         | 1   |
| 37   | H-1026*12.0                                       | Assembly, Lanyard                                    | 1   |
| 38   | G-1310-0645                                       | Pin, Ball Lok-T, 3/8" x 4.5" Grip                    | 1   |
| 39   | B-160-01  | Banner, "Remove Before Flight"                       | 1   |





## **APPENDIX I**

### **Enerpac Hand Pump Instructions & Repair Parts**





Instruction Sheet

---

Hydraulic Hand Pumps

L1763 Rev. E 06/01

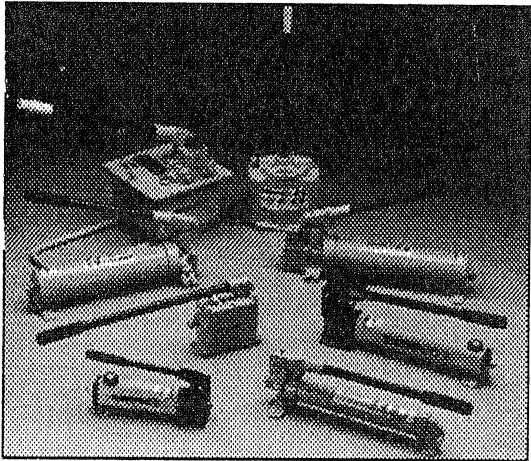

**1.0 IMPORTANT RECEIVING INSTRUCTIONS**

Visually inspect all components for shipping damage. Shipping damage is **not** covered by warranty. If shipping damage is found, notify carrier at once. The carrier is responsible for all repair and replacement costs resulting from damage in shipment.

**SAFETY FIRST**

**2.0 SAFETY ISSUES**



Read all instructions, warnings and cautions carefully. Follow all safety precautions to avoid personal injury or property damage during system operation. Enerpac cannot be responsible for damage or injury resulting from unsafe product use, lack of maintenance or incorrect product and/or system operation. Contact Enerpac when in doubt as to the safety precautions and operations. If you have never been trained on high-pressure hydraulic safety, consult your distribution or service center for a free Enerpac Hydraulic safety course.

Failure to comply with the following cautions and warnings could cause equipment damage and personal injury.

A **CAUTION** is used to indicate correct operating or maintenance procedures and practices to prevent damage to, or destruction of equipment or other property.

A **WARNING** indicates a potential danger that requires correct procedures or practices to avoid personal injury.

A **DANGER** is only used when your action or lack of action may cause serious injury or even death.



**WARNING:** Wear proper personal protective gear when operating hydraulic equipment.



**WARNING:** Stay clear of loads supported by hydraulics. A cylinder, when used as a load lifting device, should never be used as a load holding device. After the load has been raised or lowered, it must always be blocked mechanically.



**WARNING: USE ONLY RIGID PIECES TO HOLD LOADS.** Carefully select steel or wood blocks that are capable of supporting the load. Never use a hydraulic cylinder as a shim or spacer in any lifting or pressing application.



**DANGER:** To avoid personal injury keep hands and feet away from cylinder and workpiece during operation.



**WARNING:** Do not exceed equipment ratings. Never attempt to lift a load weighing more than the capacity of the cylinder. Overloading causes equipment failure and possible personal injury. The cylinders are designed for a max. pressure of 700 bar [10,000 psi]. Do not connect a jack or cylinder to a pump with a higher pressure rating.



**Never** set the relief valve to a higher pressure than the maximum rated pressure of the pump. Higher settings may result in equipment damage and/or personal injury.



**WARNING:** The system operating pressure must not exceed the pressure rating of the lowest rated component in the system. Install pressure gauges in the system to monitor operating pressure. It is your window to what is happening in the system.



**CAUTION:** Avoid damaging hydraulic hose. Avoid sharp bends and kinks when routing hydraulic hoses. Using a bent or kinked hose will cause severe back-pressure. Sharp bends and kinks will internally damage the hose leading to premature hose failure.





**Do not** drop heavy objects on hose. A sharp impact may cause internal damage to hose wire strands. Applying pressure to a damaged hose may cause it to rupture.





**IMPORTANT:** Do not lift hydraulic equipment by the hoses or swivel couplers. Use the carrying handle or other means of safe transport.

 **CAUTION:** Keep hydraulic equipment away from flames and heat. Excessive heat will soften packings and seals, resulting in fluid leaks. Heat also weakens hose materials and packings. For optimum performance do not expose equipment to temperatures of 65°C [150°F] or higher. Protect hoses and cylinders from weld spatter.

 **DANGER:** Do not handle pressurized hoses. Escaping oil under pressure can penetrate the skin, causing serious injury. If oil is injected under the skin, see a doctor immediately.

 **WARNING:** Only use hydraulic cylinders in a coupled system. Never use a cylinder with unconnected couplers. If the cylinder becomes extremely overloaded, components can fail catastrophically causing severe personal injury.

 **WARNING: BE SURE SETUP IS STABLE BEFORE LIFTING LOAD.** Cylinders should be placed on a flat surface that can support the load. Where applicable, use a cylinder base for added stability. Do not weld or otherwise modify the cylinder to attach a base or other support.

 **Avoid situations where loads are not directly centered on the cylinder plunger.** Off-center loads produce considerable strain on cylinders and plungers. In addition, the load may slip or fall, causing potentially dangerous results.

 Distribute the load evenly across the entire saddle surface. Always use a saddle to protect the plunger.

 **IMPORTANT:** Hydraulic equipment must only be serviced by a qualified hydraulic technician. For repair service, contact the Authorized ENERPAC Service Center in your area. To protect your warranty, use only ENERPAC oil.

 **WARNING:** Immediately replace worn or damaged parts by genuine ENERPAC parts. Standard grade parts will break causing personal injury and property damage. ENERPAC parts are designed to fit properly and withstand high loads.

 **CAUTION:** Always use the handle to carry the pump. Carrying the pump by the hose may damage the hose and/or the pump.

| SPECIFICATIONS – Use this instruction sheet for the following hand pump models. |              |                                   |              |  |             |  |
|---|--------------|-----------------------------------|--------------|--|-------------|--|
| Hand Pump Specifications  |              |                                   |              |  |             |  |
| Model   | Type (Speed) | Maximum Pressure Rating psi [bar] |              | Oil Volume per Stroke in <sup>3</sup> [cm <sup>3</sup> ] |             | Usable Oil Capacity in <sup>3</sup> [cm <sup>3</sup> ] |
| EHF-65  | 1            | 6,500 [440]                       |              | .16 [2.62]   |             | 22 [360]   |
| P-18  | 1            | 2,850 [200]                       |              | .16 [2.62]   |             | 22 [360]   |
| P-25  | 1            | 2,500 [170]                       |              | .58 [9.51]   |             | 231 [3786]   |
| P-39, 1003  | 1            | 10,000 [700]                      |              | .16 [2.62]   |             | 43 [705]   |
| P-50  | 1            | 5,000 [340]                       |              | .29 [4.75]   |             | 231 [3786]   |
| P-51  | 1            | 3,000 [210]                       |              | .25 [4.09]   |             | 50 [820]   |
| P-141, 1001   | 1            | 10,000 [700]                      |              | .055 [.90]   |             | 20 [328]   |
| P-391, 1004   | 1            | 10,000 [700]                      |              | .151 [2.47]  |             | 55 [900]   |
|   |              | Stage 1                           | Stage 2      | Stage 1  | Stage 2     |  |
| P-80, 1006  | 2            | 350 [25]                          | 10,000 [700] | .99 [16.23]  | .15 [2.46]  | 140 [2295]   |
| P-84  | 2            | 350 [25]                          | 10,000 [700] | .99 [16.23]  | .15 [2.46]  | 140 [2295]   |
| P-142, 1002   | 2            | 200 [14]                          | 10,000 [700] | .221 [3.62]  | .055 [.90]  | 20 [328]   |
| P-142AL   | 2            | 200 [14]                          | 10,000 [700] | .221 [3.62]  | .055 [.90]  | 9.0 [148]  |
| P-202   | 2            | 200 [14]                          | 10,000 [700] | .221 [3.62]  | .055 [.90]  | 55 [900]   |
| P-392, 1005   | 2            | 200 [14]                          | 10,000 [700] | .687 [11.26]   | .151 [2.47] | 55 [900]   |
| P-392AL   | 2            | 200 [14]                          | 10,000 [700] | .687 [11.26]   | .151 [2.47] | 55 [900]   |
| P-462   | 2            | 200 [14]                          | 10,000 [700] | 7.69 [126.00]  | .29 [4.75]  | 462 [7572]   |
| P-464   | 2            | 200 [14]                          | 10,000 [700] | 7.69 [126.00]  | .29 [4.75]  | 462 [7572]   |
| P-801   | 2            | 350 [25]                          | 10,000 [700] | .99 [16.23]  | .15 [2.46]  | 250 [4095]   |
| P-802   | 2            | 400 [28]                          | 10,000 [700] | 2.40 [39.34]   | .15 [2.46]  | 155 [2540]   |
| P-842   | 2            | 400 [28]                          | 10,000 [700] | 2.40 [39.34]   | .15 [2.46]  | 155 [2540]   |

### 3.0 DESCRIPTION

#### 3.1 Models P-141, 1001; P-142, 1002; P-202; P-391, 1004; P-392, 1005; P-802; P-842

Figure 1 and the corresponding table show the main components of hand pump models P-141, P-142, P-202, P-391, P-392, P-802, and P-842. The dual-purpose vent/fill cap acts as a pressure relief valve in case of accidental reservoir pressurization. To provide an access port at the rear of the reservoir for remote valves, use a return-to-tank kit. See the Table 1 for kit model numbers.

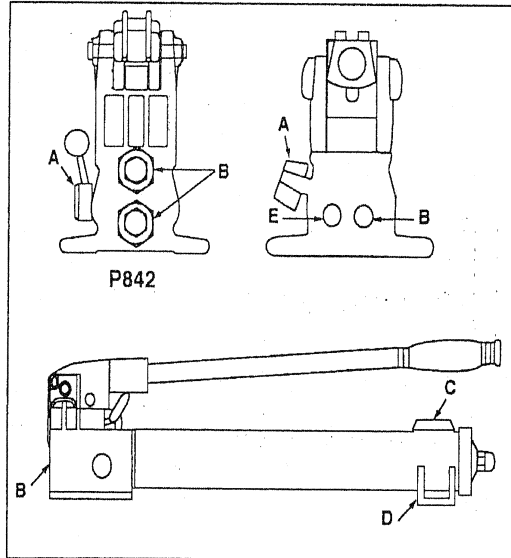

Figure 1

#### 3.2 Models P-18/P-39, 1003/P-80, 1006/P-84/P-801

Figure 2 and the corresponding table below show the main components of these hand pump models. Model P-84 is equipped with a 4-way, 3-position valve for use with double-acting cylinders. To convert models P-18 or P-39 to foot operation, order Kit PC-10.



Figure 2

**WARNING:** These pumps are operated with a non-vented reservoir. If the reservoir is subjected to high pressure, the casing may rupture, causing personal injury and/or equipment damage. NEVER attempt to return more oil to the reservoir than it is capable of holding.

| Fig. 1             | P-141, 1001          | P-142, 1002          | P-202                | P-391, 1004          | P-392, 1005          | P-802                | P-842                |
|--------------------|----------------------|----------------------|----------------------|----------------------|----------------------|----------------------|----------------------|
| A                  | Release Valve        | Release Valve        | Release Valve        | Release Valve        | Release Valve        | Release Valve        | 4-Way Valve          |
| B                  | 1/4 NPTF Outlet Port | 1/4 NPTF Outlet Port | 1/4 NPTF Outlet Port | 3/8 NPTF Outlet Port | 3/8 NPTF Outlet Port | 3/8 NPTF Outlet Port | 3/8 NPTF Outlet Port |
| C                  | Vent/Fill Cap        | Vent/Fill Cap        | Vent/Fill Cap        | Vent/Fill Cap        | Vent/Fill Cap        | Vent/Fill Cap        | Vent/Fill Cap        |
| D                  | Mounting             | Mounting Slots       | —                    | —                    | —                    | Mounting Slots       | Mounting Slots       |
| E                  | —                    | —                    | —                    | —                    | —                    | Return-to-Tank Port  | —                    |
| Return-to-Tank Kit | PC-20                | PC-20                | PC-25                | PC-25                | PC-25                | —                    | —                    |

| Fig. 2 | P-18                 | P-39, 1003           | P-80, 1006                   | P-84                 | P-801                        |
|--------|----------------------|----------------------|------------------------------|----------------------|------------------------------|
| A      | Release Valve        | Release Valve        | Release Valve                | Release Valve        | Release Valve                |
| B      | 3/8 NPTF Outlet Port | 3/8 NPTF Outlet Port | 3/8 NPTF Outlet Port         | 3/8 NPTF Outlet Port | 3/8 NPTF Outlet Port         |
| C      | Fill Plug            | Fill Plug            | Fill Plug                    | Fill Plug            | Fill Plug                    |
| D      | —                    | —                    | 1/4 NPTF Return-to-Tank Port | —                    | 1/4 NPTF Return-to-Tank Port |

### 3.3 Models P-462 and P-464

Figure 3 and the table below show the main features of hand pump models P-462, for use with single-acting cylinders, and P-464, for use with double-acting cylinders.

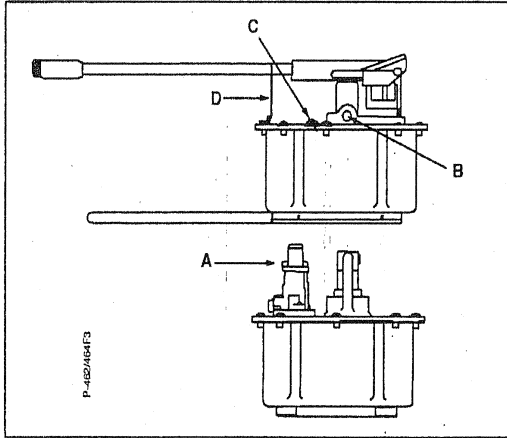

Figure 3, Models P-462, P-464

| Table 3 |                        |                        |
|---------|------------------------|------------------------|
| Fig. 3  | P-462                  | P-464                  |
| A       | 3-Way 2-Position Valve | 4-Way 3-Position Valve |
| B       | 3/8 NPTF Outlet Port   | 3/8 NPTF Outlet Port   |
| C       | Vent/Fill Plug         | Vent/Fill Plug         |
| D       | Handle Clip            | Handle Clip            |

### 3.4 Models P-25, P-50, and P-51

Figure 4 shows hand pump models P-25 and P-50, both of which are equipped with a handle that operates in both directions. Figure 5 shows the P-51 hand pump. The main components of these pumps are listed in the table below.

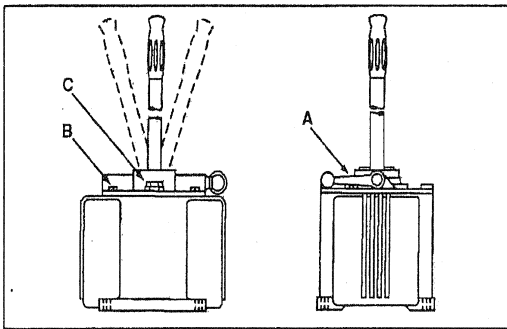

Figure 4, Models P-25 and P-50

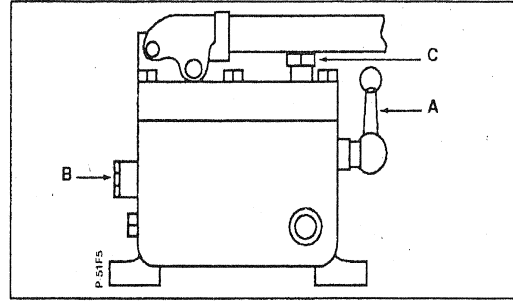

Figure 5, Model P-51

| Table 4 and 5 |                      |                      |                      |
|---------------|----------------------|----------------------|----------------------|
| Fig. 4 & 5    | P-25                 | P-50                 | P-51                 |
| A             | Release Valve        | Release Valve        | Release Valve        |
| B             | 1/4 NPTF Outlet Port | 1/4 NPTF Outlet Port | 1/4 NPTF Outlet Port |
| C             | Vent/Fill Cap        | Vent/Fill Cap        | Vent/Fill Cap        |

## 4.0 INSTALLATION

### 4.1 Connecting the Pump

1. Thread hose into pump outlet. Use 1 1/2 wraps of Teflon tape (or suitable thread sealant) on hose fitting, leaving the first complete thread free of tape to ensure that tape does not shed into hydraulic system, causing damage. Trim loose ends.
2. Install a pressure gauge in-line from the pump for added safety and better control.
3. Connect the hose(s) to your cylinder or tool.

**NOTE:** For single-acting cylinders, connect one hose from the pump to the cylinder. For double-acting cylinders, connect two hoses. Connect one hose from the pressure port of the pump to the pressure port of the cylinder. Connect another hose from the retract port of the pump to the retract port of the cylinder.

### 4.2 Pump Venting

See table below to determine if your pump should be operated with a vented or non-vented reservoir. Vented pumps provide slightly better performance. For pumps with nylon reservoir, turn vent/fill cap 1/4 turn counter-clockwise to vent. For other pumps, see decal on pump. Close vent prior to transporting pump to prevent oil leakage.

| VENTING OPTIONS           |                        |
|---------------------------|------------------------|
| EHF-65.....non-vented     | P-142AL.....non-vented |
| P-18.....non-vented       | P-202.....either       |
| P-25.....either           | P-391, 1004.....either |
| P-39, 1003.....non-vented | P-392, 1005.....either |
| P-50.....either           | P-392AL.....vented     |
| P-51.....vented           | P-462.....vented       |
| P-80, 1006.....non-vented | P-464.....vented       |
| P-84.....non-vented       | P-801.....non-vented   |
| P-141, 1001.....either    | P-802.....either       |
| P-142, 1002.....either    | P-842.....either       |

### 4.3 Pump Position

See table below to determine the correct operating position for your pump, horizontal or vertical.

| OPERATING POSITION       |                           |
|--------------------------|---------------------------|
| EHF-65.....either        | P-142AL.....either        |
| P-18.....either          | P-202.....either          |
| P-25.....horizontal only | P-391, 1004.....either    |
| P-39, 1003.....either    | P-392, 1005.....either    |
| P-50.....horizontal only | P-392AL.....either        |
| P-51.....horizontal only | P-462.....horizontal only |
| P-80, 1006.....either    | P-464.....horizontal only |
| P-84.....either          | P-801.....either          |
| P-141, 1001.....either   | P-802.....either          |
| P-142, 1002.....either   | P-842.....either          |

**NOTE:** When operating the pump in the vertical position, the hose end must be pointed down, or the pump will pick up air and will not build pressure properly.

**5.0 OPERATION**

**5.1 Before Using the Pump**

1. Check all system fittings and connections to be sure they are tight and leak free.
2. Check oil level in reservoir before operating pump. See "Adding Oil to the Pump" on page 7.



**CAUTION: NEVER add extensions to pump handle. Extensions cause unstable pump operation.**



**WARNING: In certain situations the pump handle can "kick back". Always keep your body to the side of the pump, away from the line of force of the handle.**

**NOTE:** To reduce handle effort at high pressure, take short strokes. Maximum leverage is obtained in the last 5° of stroke.

**5.2 Using Two-Speed Pumps**

These pumps provide 2-stage flow. Under no-load, the pump operates in the high flow first stage for rapid advance. When the load is contacted, the pump automatically shifts to the second stage for building pressure. For **P-462 or P-464 models**, when pump pressure reaches approximately 200 psi [14 bar], you must momentarily stop pumping and raise the handle to shift to the high pressure stage. For **P-802 or P-842 models**, when pump pressure reaches approximately 400 psi [28 bar], you must momentarily stop pumping and raise the handle to shift to the high pressure stage. After the pump shifts, pumping takes less effort.

**NOTE:** For best performance, operate pump handle at moderate speed during the high flow first stage. Rapid handle speed in the first stage will prevent the pump from delivering full volume of oil.

**5.3 Single-Acting Applications with Release Valve**

1. Close release valve by turning clockwise, as shown in Figure 6.

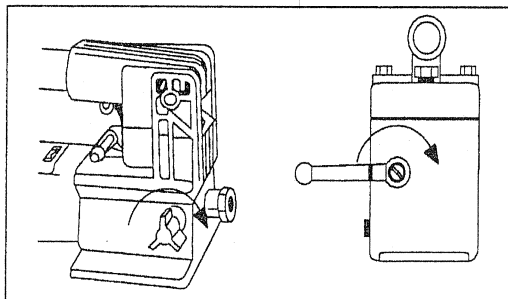

Figure 6



**CAUTION: Close release valve finger tight ONLY. Using tools on release valve can damage it and cause the pump to malfunction.**

2. Operate pump handle to deliver hydraulic power to system. Pressure will be maintained until release valve is opened.
3. Open release valve (turn counter-clockwise) to release pressure, allowing oil to flow back to the reservoir.

**5.4 Single-Acting Applications with 3-Way, 2 Position Manual Valve**

1. Shift valve handle to position 1 as shown in Figure 7.
2. Operate pump handle to deliver hydraulic power to the system. Pressure will be maintained until the valve is shifted.
3. To allow oil to return to the reservoir, shift valve handle to position 2.

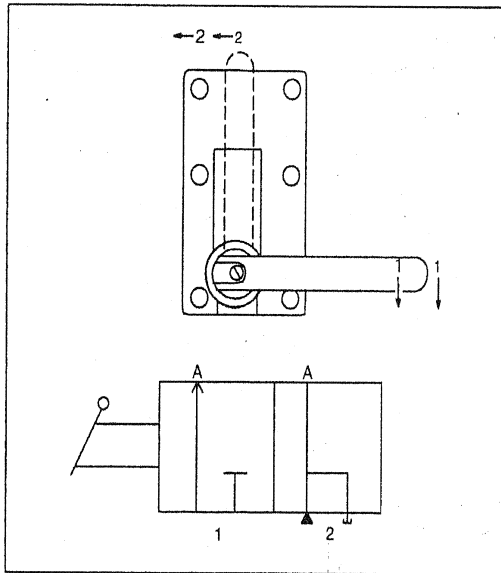

Figure 7

**5.5 Double-Acting Applications with 4-Way, 3 Position Manual Valve**

Pumps with 4-way control valves are designed to operate double-acting cylinders. See Figure 8 for valve positions.

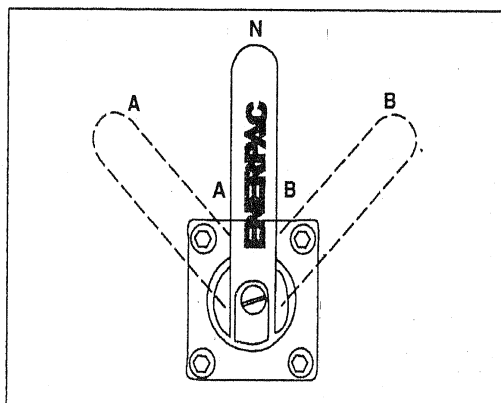

Figure 8a

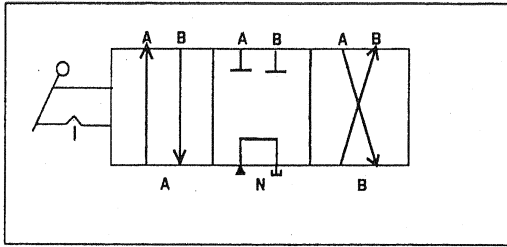

Figure 8b

1. Position lever on 4-way valve to select function as follows:  
 (A) Flow to Port "A"; port "B" returns flow to the reservoir  
 (N) Neutral; ports "A" and "B" are blocked  
 (B) Flow to port "B"; port "A" returns flow to the reservoir

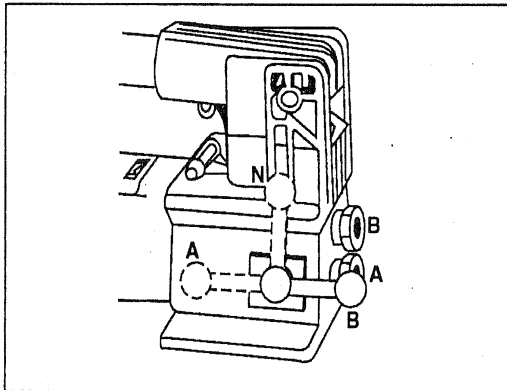

Figure 8c

2. Operate pump to perform work.
3. Change valve positions as needed.

**WARNING:** Operate double-acting cylinder only when both hoses are connected to the pump. If one coupler is left unconnected, high pressure will build behind the coupler which could cause personal injury and/or equipment damage.

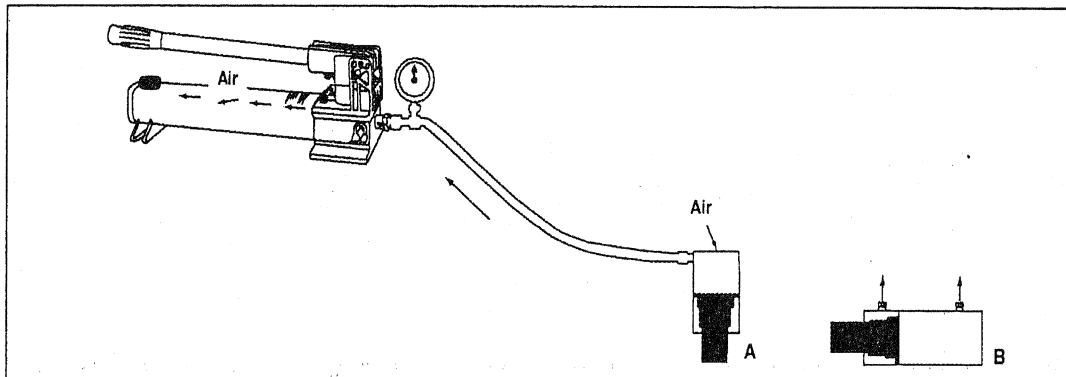

Figure 9

### 5.6 Relief Valve Adjustment

All pumps contain a factory set relief valve to prevent over-pressurization of the system. Lower pressure settings can be obtained. Contact your Authorized Enerpac Service Center.

### 6.0 AIR REMOVAL

Removing air from the hydraulic system will help the cylinder to advance and retract smoothly (see figure 9).

#### 6.1 Pump With Single-Acting Cylinder (A)

1. Vent pump reservoir (for vented pumps only) and close release valve.
2. Position pump at higher elevation than cylinder.
3. Position cylinder with the plunger end down (up if using pull cylinder). See Figure 9 below.
4. Operate pump to fully extend the cylinder (retract if using pull cylinder).
5. Open release valve to retract cylinder (extend if a pull cylinder). This will force the trapped air to move up to the pump reservoir.
6. Repeat the above steps as necessary.
7. Add oil if necessary. See page 7.
8. Return vent/fill cap to operating position.

#### 6.2 Pump With Double-Acting Cylinder (B)

1. Vent pump reservoir (for vented pumps only).
2. Position pump at higher elevation than cylinder.
3. Put cylinder in horizontal position with ports up. See Figure 9.
4. Fully advance and retract the cylinder 2 to 3 times.
5. Repeat the above steps as necessary.
6. Add oil if necessary. See page 7.
7. Return vent/fill cap to operating position.

### 7.0 MAINTENANCE

Use only Enerpac hydraulic oil with these pumps to promote long pump life and to protect your warranty. Viton and EPR seal kits are available for some hand pumps. Contact your Enerpac representative for more information on these products and their applications.

### 7.1 Adding Oil to the Pump

Check oil level regularly.



**WARNING:** Always add oil with cylinders fully retracted (extended if pull cylinders) or the system will contain more oil than the reservoir can hold.

1. Remove vent/fill cap from reservoir.
2. Fill reservoir only to level mark shown on pump.
3. Remove air from system if necessary. See page 6. Recheck oil level after removing air.
4. Return vent/fill cap to proper position.

**NOTE:** Non-vented hand pumps require air in the reservoir to function properly. If the reservoir is completely filled, a vacuum will form preventing oil from flowing out of the pump.

### 7.2 Keeping Oil Lines Clean

When coupler halves are disconnected, always screw on dust caps. Use every precaution to guard unit against entrance of dirt because foreign matter may cause pump, cylinder, or valve failure.

### 7.3 Lubricating the Pump

To extend pump life and improve performance, lubricate the beam pin (A), cross pin (B), and piston head (C) regularly, using roller bearing grease. See Figure 10.

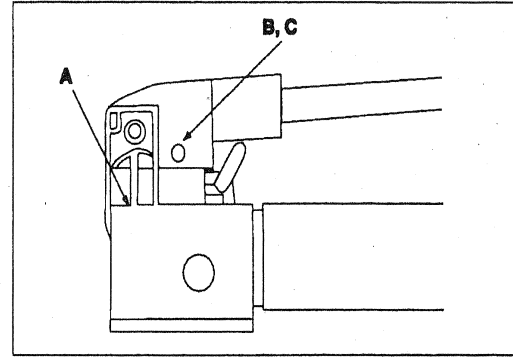

Figure 10

### 7.4 Changing the Oil

1. Drain all oil and refill with clean Enerpac oil every 12 months. If pump is used in dirty environments, change the oil more often.
2. Remove vent/fill cap or plug from reservoir.
3. Tilt pump to drain out old oil.
4. Fill reservoir only to level mark shown on pump.
5. Replace the vent/fill cap or plug.
6. Dispose of used oil properly.

## 8.0 TROUBLESHOOTING GUIDE

The following information is intended as an aid in determining if a problem exists. For repair service, contact the Authorized Enerpac Service Center in your area.

| TROUBLESHOOTING  |   |   |
|--|---|---|
| Problem  | Possible Cause  | Solution  |
| Cylinder does not advance, advances slowly, or advances in spurts.                 | <ol style="list-style-type: none"> <li>1. Oil level in pump reservoir is low.</li> <li>2. Release valve open.</li> <li>3. Loose hydraulic coupler.</li> <li>4. Load is too heavy.</li> <li>5. Air trapped in system.</li> <li>6. Cylinder plunger binding.</li> </ol>                                   | <ol style="list-style-type: none"> <li>1. Add oil according to the Maintenance instructions on page 6.</li> <li>2. Close the release valve.</li> <li>3. Check that all couplers are fully tightened.</li> <li>4. Do not attempt to lift more than rated tonnage.</li> <li>5. Remove air according to the instructions on page 6.</li> <li>6. Check for damage to cylinder. Have cylinder serviced by a qualified hydraulic technician.</li> </ol> |
| Cylinder advances, but does not hold pressure.                                     | <ol style="list-style-type: none"> <li>1. Leaking connection.</li> <li>2. Leaking seals.</li> <li>3. Internal leakage in pump.</li> </ol>   | <ol style="list-style-type: none"> <li>1. Check that all connections are tight and leak free.</li> <li>2. Locate leak(s) and have equipment serviced by a qualified hydraulic technician.</li> <li>3. Have pump serviced by a qualified hydraulic technician.</li> </ol>  |
| Cylinder does not retract, retracts part way, or retracts more slowly than normal. | <ol style="list-style-type: none"> <li>1. Release valve closed.</li> <li>2. Pump reservoir is over-filled.</li> <li>3. Loose hydraulic coupler.</li> <li>4. Air trapped in system.</li> <li>5. Hose I.D. too narrow.</li> <li>6. Cylinder retraction spring broken or other cylinder damage.</li> </ol> | <ol style="list-style-type: none"> <li>1. Open release valve.</li> <li>2. Drain oil level to full mark. See page 7 instructions for adding oil.</li> <li>3. Check that all couplers are fully tightened.</li> <li>4. Remove air according to the instructions on page 6.</li> <li>5. Use larger diameter hydraulic hose.</li> <li>6. Have cylinder serviced by a qualified hydraulic technician.</li> </ol>                                       |

**Enerpac Worldwide Locations**

+ e-mail: [info@enerpac.com](mailto:info@enerpac.com)

+ internet: [www.enerpac.com](http://www.enerpac.com)

**Australia**

ENERPAC, Applied Power Australia Ltd.  
Block V Unit 3  
Regents Park Estate  
391 Park Road  
Regents Park NSW 2143  
(P.O. Box 261) Australia  
Tel: +61 297 438 988  
Fax: +61 297 438 648

**Canada**

Applied Power Canada Ltd.  
6615 Ordan Drive, Unit 14-15  
Mississauga, Ontario L5T 1X2  
Tel: +1 905 564 5749  
Fax: +1 905 564 0305

**Toll Free:**

Tel: +1 800 268 4987  
Fax: +1 800 461 2456

**China**

Applied Power China Ltd.  
1F, 269 Fute N. Road  
Waigaoqiao Free Trade Zone  
Pudong New District  
Shanghai, 200 131  
China  
Tel: +86 21 5866 9099  
Fax: +86 21 5866 7156

**France, Turkey, Greece,  
Africa, Middle East**

ENERPAC S.A.  
B.P. 200  
Parc d'Activités  
du Moulin de Massy  
F-91882 Massy CEDEX (Paris) France  
Tel: +33 1 601 368 68  
Fax: +33 1 692 037 50

**Germany, Switzerland,  
Austria, Eastern Europe**

ENERPAC  
Applied Power GmbH  
P.O. Box 300113  
D-40401 Düsseldorf  
Germany  
Tel: +49 211 471 490  
Fax: +49 211 471 49 28

**Hong Kong**

ENERPAC  
Room 907 Workingberg  
Commercial Building  
41-47 Marble Road  
North Point  
Tel: +852-2561 6295  
Fax: +852-2561 6772

**India**

ENERPAC  
Hydraulics (India) Pvt Ltd  
Plot No. A-571  
MIDC, TTC Industrial Area  
Mahape-400 701  
Navi Mumbai, India  
Tel: +91 22 769 47 78  
Fax: +91 22 769 84 73

**Italy**

ENERPAC  
Applied Power Italiana S.p.A.  
Via Canova 4  
20094 Corsico (Milano)  
Tel: +39 2 486 111 00  
Fax: +39 2 486 012 88

**Japan**

Applied Power Japan Ltd.  
1-1-11, Shimomae  
Toda-shi  
Saitama Pref.  
Japan 335-0016  
Tel: +81-48-430-2311  
Fax: +81-48-430-1117

**Mexico**

ENERPAC Applied Power  
Mexico S.A. de C.V.  
Avenida Principal  
La Paz #100  
Fracc. Industrial La Paz  
42092 Pachuca, Hidalgo  
Tel: +52 771 337 00  
Fax: +52 771 838 00

**The Netherlands, Belgium,  
Luxembourg, Sweden, Denmark,  
Norway, Finland, United Kingdom,  
Ireland**

ENERPAC B.V.  
Storkstraat 25  
P.O. Box 269, 3900 AG Veenendaal  
The Netherlands  
Tel: +31 318 535 911  
Fax: +31 318 525 613  
+31 318 535 848  
UK, Ireland  
Tel: +44 01527 598 900  
Fax: +44 01527 585 500

**Singapore**

Applied Power Asia Pte Ltd  
No. 8, Ang Mo Kio,  
Industrial Park 2  
#01-00  
Singapore 569500  
Thomson Road, P.O. Box 114  
Singapore 915704  
Tel: +65 484 5108  
Fax: +65 484 5669

**South Korea**

ENERPAC  
Applied Power Korea Ltd.  
163-12 Dodang-Dong  
Wonmi-Ku, Buchun-shi  
Kyunggi-Do  
Republic of Korea  
Tel: +82 32 675 08 36  
Fax: +82 32 675 30 02/73

**Spain, Portugal**

ENERPAC  
Applied Power International S.A.  
Avda. Camino de lo Cortao  
21 - Nave 3  
San Sebastian de los Reyes  
28709 Madrid  
Spain  
Tel: +34 91 661 11 25  
Fax: +34 91 661 47 89

**USA, Latin America  
and Caribbean**

ENERPAC  
P.O. Box 3241  
6101 N. Baker Road  
Milwaukee, WI 53209 USA  
Tel: +1 262 781 6600  
Fax: +1 262 781 1049

**User inquiries:**

+1 800 433 2766

**Distributor inquiries/orders:**

+1 800 558 0530

All Enerpac products are guaranteed against defects in workmanship and materials for as long as you own them.  
For your nearest authorized Enerpac Service Center, visit us at [www.enerpac.com](http://www.enerpac.com)

|   |  |
|---|--|
|  | <h2 style="margin: 0;">Repair Parts Sheet</h2> <p style="margin: 5px 0 0 0;">P-391, 1004 / P-392, 1005</p> |
|---|--|

L1771 Rev. D 12/00

For Date Codes Beginning with the Letter "B"

**To Protect Your Warranty, Use Only ENERPAC Hydraulic Oil.**  
 Enerpac recommends that all kit components be installed to insure optimum performance of the repaired product.

**WARNING:**

To ensure that the internal relief valve setting is correct, check the model number when servicing the product. The setting may require adjustment based on the pressure setting designated by the dash code (-XXXX) of the model number.

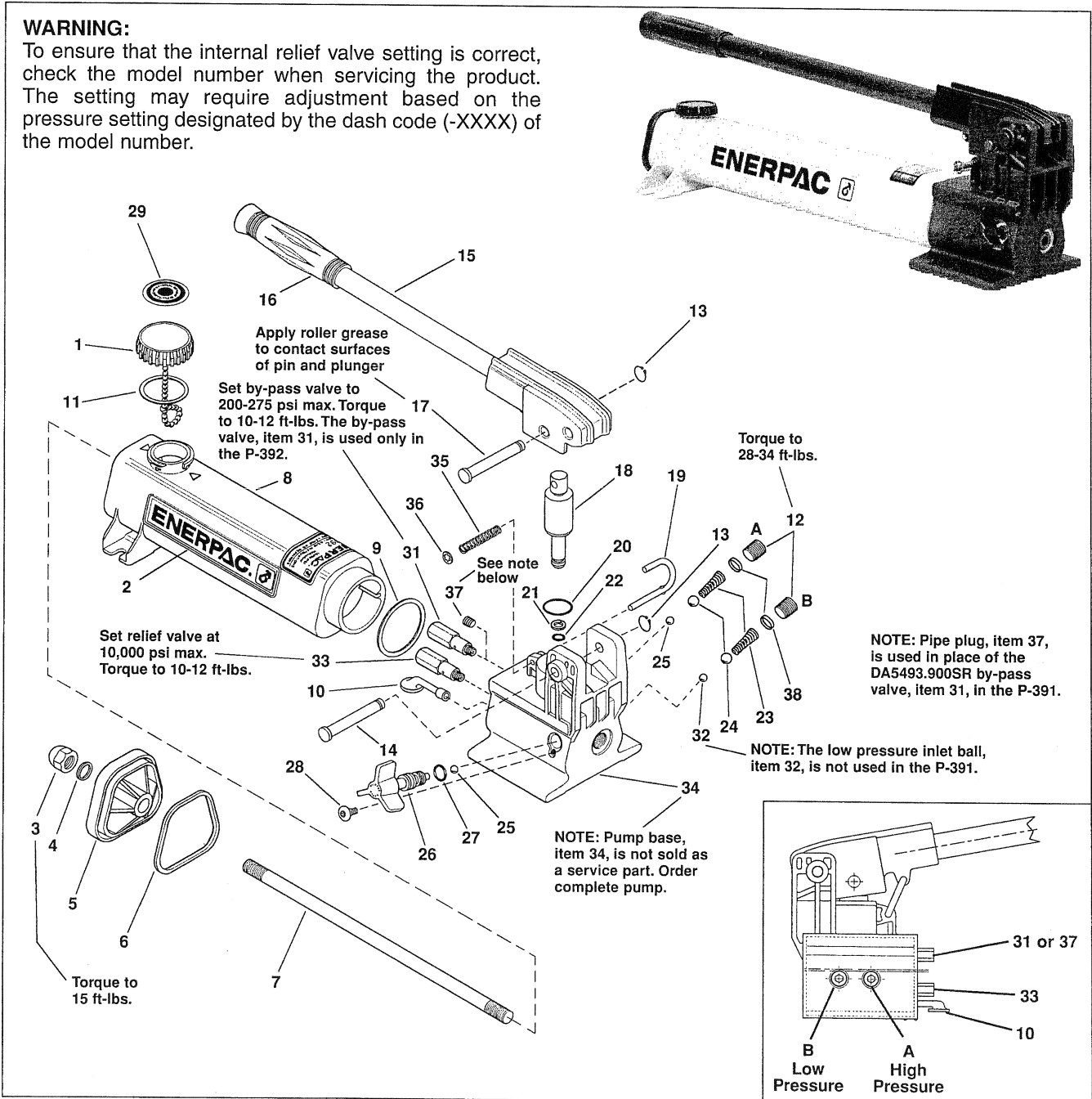
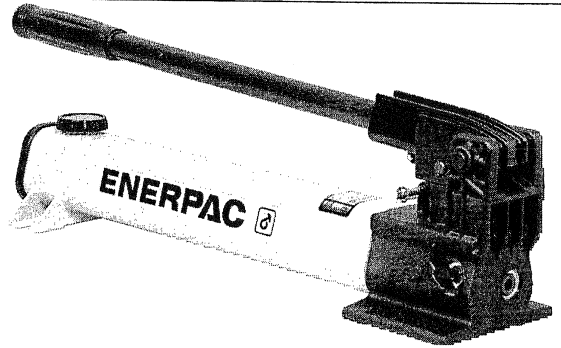

**Repair Parts List for Figure 1**

| Item | Part No.    | Qty. | Description                                   | Item | Part No.            | Qty. | Description                            |
|------|-------------|------|---|------|---------------------|------|--|
| 1    | CN766950SR  | 1    | Vent Cap Assembly (incl. item 11,29)          | 19   | CM927061SR          | 1    | Locking Pin (incl. item 35,36)         |
| 2    | ★           | 1    | Enerpac Decal                                 | 20   | ★                   | 1    | O-Ring                                 |
| 3    | CL341055    | 1    | Acorn Nut                                     | 21   | ★                   | 1    | Back-Up Ring                           |
| 4    | ★           | 1    | Gasket  | 22   | ★                   | 1    | O-Ring                                 |
| 5    | CN814020SR  | 1    | End Cap (incl. item 3,4,6)                    | 23   | ★                   | 2    | Spring                                 |
| 6    | ★           | 1    | Gasket O-Ring                                 | 24   | ★                   | 2    | 5/16" Ball                             |
| 7    | CL127149    | 1    | Tie Rod                                       | 25   | ★                   | 2    | 7/32" Ball                             |
| 8    | CR72025SR   | 1    | Reservoir<br>(yellow incl. item 2,3,4,6,9,11) | 26   | CL913900SR          | 1    | Spindle Assembly (incl. item 25,27,28) |
|      | S95032025   | 1    | Reservoir (red incl. item 2,3,4,6,9,11)       | 27   | ★                   | 1    | O-Ring                                 |
| 9    | ★           | 1    | Gasket  | 28   | ★                   | 1    | Screw                                  |
| 10   | DA3729900SR | 1    | Oil Filter                                    | 29   | ★                   | 1    | Vent Cap Decal                         |
| 11   | ★           | 1    | Gasket  | 31   | DA5493900SR         | 1    | Bypass Valve (P392 Only)               |
| 12   | CN815006    | 2    | Pipe Plug                                     | 32   | ★                   | 1    | 7/32" Inlet Check Ball (P392 Only)     |
| 13   | ★           | 2    | Retaining Ring                                | 33   | DA8802900SR         | 1    | Relief Valve                           |
| 14   | ★CR214061SR | 1    | Beam Pin (incl. item 13)                      | 34   | Order complete pump | 1    | Base (not available as service item)   |
| 15   | CL918900SR  | 1    | Beam and Handle Assembly                      | 35   | ★                   | 1    | Spring                                 |
| 16   | CL343550    | 1    | Handle Grip                                   | 36   | ★                   | 1    | Retaining Ring                         |
| 17   | DC106061SR1 | 1    | Cross Pin                                     | 37   | A1006245            | 1    | Pipe Plug (P391 Only)                  |
| 18   | CR333040SR  | 1    | Plunger Assembly (incl. item 13,17,21,22)     | 38   | ★                   | 2    | Spring Cap                             |

★ Indicates items included in, and available only as part of Repair Kit P391K2

**NOTE:** Bypass Valve, Item 31, and Inlet Check Ball, Item 32, are not used in the single-speed P391 model Pump.  
Use Item 37 in place of Item 31.

**Enerpac Worldwide Locations**

✦ e-mail: [info@enerpac.com](mailto:info@enerpac.com)

✦ internet: [www.enerpac.com](http://www.enerpac.com)

**Australia**

ENERPAC, Applied Power Australia Ltd.  
Block V Unit 3  
Regents Park Estate  
391 Park Road  
Regents Park NSW 2143  
(P.O. Box 261) Australia  
Tel: +61 297 438 988  
Fax: +61 297 438 648

**Canada**

Applied Power Canada Ltd.  
6615 Ordan Drive, Unit 14-15  
Mississauga, Ontario L5T 1X2  
Tel: +1 905 564 5749  
Fax: +1 905 564 0305

**Toll Free:**

Tel: +1 800 268 4987  
Fax: +1 800 461 2456

**China**

Shanghai Blackhawk  
Machinery Co Ltd  
15H Jinxuang Building  
238 Nandan Road (E)  
Shanghai, 200030  
China  
Tel: +86 21 5866 9099  
Fax: +86 21 5866 7156

**France, Turkey, Greece,  
Africa, Middle East**

ENERPAC S.A.  
B.P. 200  
Parc d'Activités  
du Moulin de Massy  
F-91882 Massy CEDEX (Paris) France  
Tel: +33 1 601 368 68  
Fax: +33 1 692 037 50

**Germany, Switzerland,  
Austria, Eastern Europe**

ENERPAC  
Applied Power GmbH  
P.O. Box 300113  
D-40401 Düsseldorf  
Germany  
Tel: +49 211 471 490  
Fax: +49 211 471 49 28

**Hong Kong**

ENERPAC  
Room 907 Workingberg  
Commercial Building  
41-47 Marble Road  
North Point  
Tel: +852-2561 6295  
Fax: +852-2561 6772

**India**

ENERPAC  
Hydraulics Technology  
(India) Pvt Ltd  
Plot No. A-571  
MIDC, TTC Industrial Area  
Mahape-400 701  
Navi Mumbai, India  
Tel: +91 22 769 47 78  
Fax: +91 22 769 84 73

**Italy**

ENERPAC  
Applied Power Italiana S.p.A.  
Via Canova 4  
20094 Corsico (Milano)  
Tel: +39 2 486 111 00  
Fax: +39 2 486 012 88

**Japan**

Applied Power Japan Ltd.  
1-1-11, Shimomae  
Toda-shi  
Saitama Pref.  
Japan 335-0016  
Tel: +81-48-430-1055  
Fax: +81-48-430-1066

**Mexico**

ENERPAC Applied Power  
Mexico S.A. de C.V.  
Avenida Principal  
La Paz #100  
Fracc. Industrial La Paz  
42084 Pachuca, Hidalgo  
Tel: +52 771 337 00  
Fax: +52 771 838 00

**The Netherlands, Belgium, Luxembourg,  
Sweden, Denmark, Norway, Finland**

ENERPAC B.V.  
Storkstraat 25 /  
P.O. Box 269, 3900 AG Veenendaal  
The Netherlands  
Tel: +31 318 535 911  
Fax: +31 318 525 613  
+31 318 535 848

**Singapore**

Applied Power Asia Pte Ltd  
No. 8, Ang Mo Kio,  
Industrial Park 2  
#01-00  
Singapore 569500  
Thomson Road  
P.O. Box 114  
Singapore 915704  
Tel: +65 484 5108  
Fax: +65 484 5669

**South Korea**

ENERPAC  
Applied Power Korea Ltd.  
163-12 Dodang-Dong  
Choong-Ku, Buchun-shi  
Kyunggi-Do  
Republic of Korea  
Tel: +82 32 675 08 36  
Fax: +82 32 675 30 02

**Spain, Portugal**

ENERPAC  
Applied Power International S.A.  
Avda. Camino de lo Cortado 21  
San Sebastian de los Reyes  
28709 Madrid  
Spain  
Tel: +34 91 661 11 25  
Fax: +34 91 661 47 89

**United Kingdom, Ireland**

ENERPAC Limited  
Unit 3, Colermeadow Road  
North Moons Moat  
Redditch  
Worcester B98 9BP  
United Kingdom  
Tel: +44 01527 598 900  
Fax: +44 01527 585 500

**USA, Latin America  
and Caribbean**

ENERPAC  
P.O. Box 3241  
6101 N. Baker Road  
Milwaukee, WI 53209 USA  
Tel: +1 262 781 6600  
Fax: +1 262 781 1049

**User inquiries:**  
+1 800 433 2766  
**Distributor inquiries/orders:**  
+1 800 558 0530

All Enerpac products are guaranteed against defects in workmanship and materials for as long as you own them.  
For your nearest authorized Enerpac Service Center, visit us at [www.enerpac.com](http://www.enerpac.com)



## APPENDIX II

### Safety Data Sheet MIL-PRF-5606 Hydraulic Fluid





Product Name: MOBIL AERO HFA  
Revision Date: 01 Oct 2015  
Page 1 of 12

## SAFETY DATA SHEET

### SECTION 1 PRODUCT AND COMPANY IDENTIFICATION

#### PRODUCT

**Product Name:** MOBIL AERO HFA  
**Product Description:** Base Oil and Additives  
**Product Code:** 201550401020, 490110-00, 970584  
**Intended Use:** Aviation hydraulic oil

#### COMPANY IDENTIFICATION

**Supplier:** EXXON MOBIL CORPORATION  
22777 Springwoods Village Parkway  
Spring, TX. 77253 USA  
**24 Hour Health Emergency** 609-737-4411  
**Transportation Emergency Phone** 800-424-9300 or 703-527-3887 CHEMTREC  
**Product Technical Information** 800-662-4525  
**MSDS Internet Address** <http://www.exxon.com>, <http://www.mobil.com>

### SECTION 2 HAZARDS IDENTIFICATION

This material is hazardous according to regulatory guidelines (see (M)SDS Section 15).

#### CLASSIFICATION:

Flammable liquid: Category 4.  
Aspiration toxicant: Category 1.

#### LABEL:

Pictogram:



**Signal Word:** Danger

#### Hazard Statements:

H227: Combustible liquid. H304: May be fatal if swallowed and enters airways.

#### Precautionary Statements:

P210: Keep away from flames and hot surfaces. -- No smoking. P273: Avoid release to the environment. P280: Wear protective gloves and eye / face protection. P301 + P310: IF SWALLOWED: Immediately call a POISON CENTER or doctor/physician. P331: Do NOT induce vomiting. P370 + P378: In case of fire: Use water fog, foam, dry chemical or carbon dioxide (CO2) to extinguish. P403 + P235: Store in a well-ventilated place. Keep cool. P405: Store locked up. P501: Dispose of contents and container in accordance with local regulations.



Product Name: MOBIL AERO HFA  
 Revision Date: 01 Oct 2015  
 Page 2 of 12

**Other hazard information:**

**HAZARD NOT OTHERWISE CLASSIFIED (HNOC):** None as defined under 29 CFR 1910.1200.

**PHYSICAL / CHEMICAL HAZARDS**

Material can accumulate static charges which may cause an ignition. Material can release vapors that readily form flammable mixtures. Vapor accumulation could flash and/or explode if ignited. Combustible.

**HEALTH HAZARDS**

High-pressure injection under skin may cause serious damage. Excessive exposure may result in eye, skin, or respiratory irritation.

**ENVIRONMENTAL HAZARDS**

No significant hazards.

**NFPA Hazard ID:** Health: 1 Flammability: 2 Reactivity: 0  
**HMIS Hazard ID:** Health: 1\* Flammability: 2 Reactivity: 0

**NOTE:** This material should not be used for any other purpose than the intended use in Section 1 without expert advice. Health studies have shown that chemical exposure may cause potential human health risks which may vary from person to person.

**SECTION 3 COMPOSITION / INFORMATION ON INGREDIENTS**

This material is defined as a mixture.

**Hazardous Substance(s) or Complex Substance(s) required for disclosure**

| Name   | CAS#       | Concentration* | GHS Hazard Codes                      |
|--|------------|----------------|---------------------------------------|
| 2,6-DI-TERT-BUTYL-P-CRESOL                           | 128-37-0   | 0.1 - < 1%     | H400(M factor 1),<br>H410(M factor 1) |
| DISTILLATES (PETROLEUM), HYDROTREATED LIGHT          | 64742-47-8 | 5 - < 10%      | H304                                  |
| HYDROTREATED LIGHT NAPHTHENIC DISTILLATE (PETROLEUM) | 64742-53-6 | 50 - < 70%     | H227, H304                            |
| HYDROTREATED MIDDLE DISTILLATE (PETROLEUM)           | 64742-46-7 | 20 - < 30%     | H304                                  |
| TRIPHENYL PHOSPHATE                                  | 115-86-6   | 0.1 - < 0.25%  | H400(M factor 1),<br>H410(M factor 1) |

\* All concentrations are percent by weight unless material is a gas. Gas concentrations are in percent by volume.

As per paragraph (i) of 29 CFR 1910.1200, formulation is considered a trade secret and specific chemical identity and exact percentage (concentration) of composition may have been withheld. Specific chemical identity and exact percentage composition will be provided to health professionals, employees, or designated representatives in accordance with applicable provisions of paragraph (i).

**SECTION 4 FIRST AID MEASURES**

**INHALATION**



Product Name: MOBIL AERO HFA  
Revision Date: 01 Oct 2015  
Page 3 of 12

Remove from further exposure. For those providing assistance, avoid exposure to yourself or others. Use adequate respiratory protection. If respiratory irritation, dizziness, nausea, or unconsciousness occurs, seek immediate medical assistance. If breathing has stopped, assist ventilation with a mechanical device or use mouth-to-mouth resuscitation.

#### SKIN CONTACT

Wash contact areas with soap and water. Remove contaminated clothing. Launder contaminated clothing before reuse. If product is injected into or under the skin, or into any part of the body, regardless of the appearance of the wound or its size, the individual should be evaluated immediately by a physician as a surgical emergency. Even though initial symptoms from high pressure injection may be minimal or absent, early surgical treatment within the first few hours may significantly reduce the ultimate extent of injury.

#### EYE CONTACT

Flush thoroughly with water. If irritation occurs, get medical assistance.

#### INGESTION

Seek immediate medical attention. Do not induce vomiting.

#### NOTE TO PHYSICIAN

If ingested, material may be aspirated into the lungs and cause chemical pneumonitis. Treat appropriately.

### SECTION 5 FIRE FIGHTING MEASURES

#### EXTINGUISHING MEDIA

**Appropriate Extinguishing Media:** Use water fog, foam, dry chemical or carbon dioxide (CO<sub>2</sub>) to extinguish flames.

**Inappropriate Extinguishing Media:** Straight Streams of Water

#### FIRE FIGHTING

**Fire Fighting Instructions:** Evacuate area. Prevent runoff from fire control or dilution from entering streams, sewers, or drinking water supply. Firefighters should use standard protective equipment and in enclosed spaces, self-contained breathing apparatus (SCBA). Use water spray to cool fire exposed surfaces and to protect personnel.

**Unusual Fire Hazards:** Combustible. Pressurized mists may form a flammable mixture.

**Hazardous Combustion Products:** Aldehydes, Incomplete combustion products, Oxides of carbon, Phosphorus oxides, Smoke, Fume, Sulfur oxides

#### FLAMMABILITY PROPERTIES

**Flash Point [Method]:** >82°C (180°F) [ASTM D-93]

**Flammable Limits (Approximate volume % in air):** LEL: 0.7 UEL: 7.0 [Estimated]

**Autoignition Temperature:** >225°C (437°F)

### SECTION 6 ACCIDENTAL RELEASE MEASURES

#### NOTIFICATION PROCEDURES

In the event of a spill or accidental release, notify relevant authorities in accordance with all applicable



Product Name: MOBIL AERO HFA  
Revision Date: 01 Oct 2015  
Page 4 of 12

regulations. US regulations require reporting releases of this material to the environment which exceed the applicable reportable quantity or oil spills which could reach any waterway including intermittent dry creeks. The National Response Center can be reached at (800)424-8802.

#### PROTECTIVE MEASURES

Avoid contact with spilled material. Warn or evacuate occupants in surrounding and downwind areas if required due to toxicity or flammability of the material. See Section 5 for fire fighting information. See the Hazard Identification Section for Significant Hazards. See Section 4 for First Aid Advice. See Section 8 for advice on the minimum requirements for personal protective equipment. Additional protective measures may be necessary, depending on the specific circumstances and/or the expert judgment of the emergency responders.

For emergency responders: Respiratory protection: respiratory protection will be necessary only in special cases, e.g., formation of mists. Half-face or full-face respirator with filter(s) for dust/organic vapor or Self Contained Breathing Apparatus (SCBA) can be used depending on the size of spill and potential level of exposure. If the exposure cannot be completely characterized or an oxygen deficient atmosphere is possible or anticipated, SCBA is recommended. Work gloves that are resistant to hydrocarbons are recommended. Gloves made of polyvinyl acetate (PVA) are not water-resistant and are not suitable for emergency use. Chemical goggles are recommended if splashes or contact with eyes is possible. Small spills: normal antistatic work clothes are usually adequate. Large spills: full body suit of chemical resistant, antistatic material is recommended.

#### SPILL MANAGEMENT

**Land Spill:** Eliminate all ignition sources (no smoking, flares, sparks or flames in immediate area). Stop leak if you can do it without risk. All equipment used when handling the product must be grounded. Do not touch or walk through spilled material. Prevent entry into waterways, sewer, basements or confined areas. A vapor suppressing foam may be used to reduce vapors. Use clean non-sparking tools to collect absorbed material. Absorb or cover with dry earth, sand or other non-combustible material and transfer to containers. Large Spills: Water spray may reduce vapor; but may not prevent ignition in closed spaces. Recover by pumping or with suitable absorbent.

**Water Spill:** Stop leak if you can do it without risk. Confine the spill immediately with booms. Warn other shipping. Remove from the surface by skimming or with suitable absorbents. Seek the advice of a specialist before using dispersants.

Water spill and land spill recommendations are based on the most likely spill scenario for this material; however, geographic conditions, wind, temperature, (and in the case of a water spill) wave and current direction and speed may greatly influence the appropriate action to be taken. For this reason, local experts should be consulted. Note: Local regulations may prescribe or limit action to be taken.

#### ENVIRONMENTAL PRECAUTIONS

Large Spills: Dike far ahead of liquid spill for later recovery and disposal. Prevent entry into waterways, sewers, basements or confined areas.

|                  |                             |
|------------------|-----------------------------|
| <b>SECTION 7</b> | <b>HANDLING AND STORAGE</b> |
|------------------|-----------------------------|

#### HANDLING

Avoid contact with skin. Avoid prolonged breathing of mists and heated vapor. Prevent small spills and leakage to avoid slip hazard. Material can accumulate static charges which may cause an electrical spark (ignition source). When the material is handled in bulk, an electrical spark could ignite any flammable vapors from liquids or residues that may be present (e.g., during switch-loading operations). Use proper bonding and/or ground procedures. However, bonding and grounds may not eliminate the hazard from static



Product Name: MOBIL AERO HFA

Revision Date: 01 Oct 2015

Page 5 of 12

accumulation. Consult local applicable standards for guidance. Additional references include American Petroleum Institute 2003 (Protection Against Ignitions Arising out of Static, Lightning and Stray Currents) or National Fire Protection Agency 77 (Recommended Practice on Static Electricity) or GENELEC CLC/TR 50404 (Electrostatics - Code of practice for the avoidance of hazards due to static electricity).

**Static Accumulator:** This material is a static accumulator.

## STORAGE

The container choice, for example storage vessel, may effect static accumulation and dissipation. Keep container closed. Handle containers with care. Open slowly in order to control possible pressure release. Store in a cool, well-ventilated area. Storage containers should be grounded and bonded. Fixed storage containers, transfer containers and associated equipment should be grounded and bonded to prevent accumulation of static charge.

## SECTION 8 EXPOSURE CONTROLS / PERSONAL PROTECTION

### EXPOSURE LIMIT VALUES

Exposure limits/standards (Note: Exposure limits are not additive)

| Substance Name  | Form                         | Limit / Standard |                       | NOTE | Source  |
|---|------------------------------|------------------|-----------------------|------|---------|
| 2,6-DI-TERT-BUTYL-P-CRESOL  | Inhalable fraction and vapor | TWA              | 2 mg/m <sup>3</sup>   | N/A  | ACGIH   |
| DISTILLATES (PETROLEUM), HYDROTREATED LIGHT [total hydrocarbon vapor] | Non-Aerosol                  | TWA              | 200 mg/m <sup>3</sup> | Skin | ACGIH   |
| HYDROTREATED LIGHT NAPHTHENIC DISTILLATE (PETROLEUM)                  | Mist.                        | TWA              | 5 mg/m <sup>3</sup>   | N/A  | OSHA Z1 |
| HYDROTREATED LIGHT NAPHTHENIC DISTILLATE (PETROLEUM)                  | Inhalable fraction.          | TWA              | 5 mg/m <sup>3</sup>   | N/A  | ACGIH   |
| HYDROTREATED LIGHT NAPHTHENIC DISTILLATE (PETROLEUM)                  | Mist.                        | TWA              | 5 mg/m <sup>3</sup>   | N/A  | ACGIH   |
| HYDROTREATED MIDDLE DISTILLATE (PETROLEUM)                            | Mist.                        | TWA              | 5 mg/m <sup>3</sup>   | N/A  | OSHA Z1 |
| HYDROTREATED MIDDLE DISTILLATE (PETROLEUM)                            | Inhalable fraction.          | TWA              | 5 mg/m <sup>3</sup>   | N/A  | ACGIH   |
| TRIPHENYL PHOSPHATE   |                              | TWA              | 3 mg/m <sup>3</sup>   | N/A  | OSHA Z1 |
| TRIPHENYL PHOSPHATE   |                              | TWA              | 3 mg/m <sup>3</sup>   | N/A  | ACGIH   |

**Exposure limits/standards for materials that can be formed when handling this product:** When mists/aerosols can occur the following are recommended: 5 mg/m<sup>3</sup> - ACGIH TLV (inhalable fraction), 5 mg/m<sup>3</sup> - OSHA PEL.

NOTE: Limits/standards shown for guidance only. Follow applicable regulations.

No biological limits allocated.

### ENGINEERING CONTROLS

The level of protection and types of controls necessary will vary depending upon potential exposure conditions.



Product Name: MOBIL AERO HFA  
Revision Date: 01 Oct 2015  
Page 6 of 12

---

Control measures to consider:  
Use explosion-proof ventilation equipment to stay below exposure limits.

## PERSONAL PROTECTION

Personal protective equipment selections vary based on potential exposure conditions such as applications, handling practices, concentration and ventilation. Information on the selection of protective equipment for use with this material, as provided below, is based upon intended, normal usage.

**Respiratory Protection:** If engineering controls do not maintain airborne contaminant concentrations at a level which is adequate to protect worker health, an approved respirator may be appropriate. Respirator selection, use, and maintenance must be in accordance with regulatory requirements, if applicable. Types of respirators to be considered for this material include:

No special requirements under ordinary conditions of use and with adequate ventilation.

For high airborne concentrations, use an approved supplied-air respirator, operated in positive pressure mode. Supplied air respirators with an escape bottle may be appropriate when oxygen levels are inadequate, gas/vapor warning properties are poor, or if air purifying filter capacity/rating may be exceeded.

**Hand Protection:** Any specific glove information provided is based on published literature and glove manufacturer data. Glove suitability and breakthrough time will differ depending on the specific use conditions. Contact the glove manufacturer for specific advice on glove selection and breakthrough times for your use conditions. Inspect and replace worn or damaged gloves. The types of gloves to be considered for this material include:

If prolonged or repeated contact is likely, chemical resistant gloves are recommended. If contact with forearms is likely, wear gauntlet style gloves.

**Eye Protection:** If contact is likely, safety glasses with side shields are recommended.

**Skin and Body Protection:** Any specific clothing information provided is based on published literature or manufacturer data. The types of clothing to be considered for this material include:

If prolonged or repeated contact is likely, chemical, and oil resistant clothing is recommended.

**Specific Hygiene Measures:** Always observe good personal hygiene measures, such as washing after handling the material and before eating, drinking, and/or smoking. Routinely wash work clothing and protective equipment to remove contaminants. Discard contaminated clothing and footwear that cannot be cleaned. Practice good housekeeping.

## ENVIRONMENTAL CONTROLS

Comply with applicable environmental regulations limiting discharge to air, water and soil. Protect the environment by applying appropriate control measures to prevent or limit emissions.

|                  |   |
|------------------|---|
| <b>SECTION 9</b> | <b>PHYSICAL AND CHEMICAL PROPERTIES</b> |
|------------------|---|

**Note:** Physical and chemical properties are provided for safety, health and environmental considerations only and may not fully represent product specifications. Contact the Supplier for additional information.

## GENERAL INFORMATION

**Physical State:** Liquid  
**Color:** Red



Product Name: MOBIL AERO HFA  
 Revision Date: 01 Oct 2015  
 Page 7 of 12

**Odor:** Characteristic  
**Odor Threshold:** N/D

#### IMPORTANT HEALTH, SAFETY, AND ENVIRONMENTAL INFORMATION

**Relative Density (at 15 °C):** 0.88  
**Flammability (Solid, Gas):** N/A  
**Flash Point [Method]:** >82°C (180°F) [ASTM D-93]  
**Flammable Limits (Approximate volume % in air):** LEL: 0.7 UEL: 7.0 [Estimated]  
**Autoignition Temperature:** >225°C (437°F)  
**Boiling Point / Range:** N/D  
**Decomposition Temperature:** N/D  
**Vapor Density (Air = 1):** N/D  
**Vapor Pressure:** [N/D at 20 °C]  
**Evaporation Rate (n-butyl acetate = 1):** N/D  
**pH:** N/A  
**Log Pow (n-Octanol/Water Partition Coefficient):** N/D  
**Solubility in Water:** Negligible  
**Viscosity:** 13.8 cSt (13.8 mm<sup>2</sup>/sec) at 40 °C | 5.1 cSt (5.1 mm<sup>2</sup>/sec) at 100°C [ASTM D 445]  
**Oxidizing Properties:** See Hazards Identification Section.

#### OTHER INFORMATION

**Freezing Point:** N/D  
**Melting Point:** N/A  
**Pour Point:** -60°C (-76°F) [ASTM D97]  
**DMSO Extract (mineral oil only), IP-346:** < 3 %wt

### SECTION 10 STABILITY AND REACTIVITY

**REACTIVITY:** See sub-sections below.

**STABILITY:** Material is stable under normal conditions.

**CONDITIONS TO AVOID:** Open flames and high energy ignition sources.

**MATERIALS TO AVOID:** Strong oxidizers

**HAZARDOUS DECOMPOSITION PRODUCTS:** Material does not decompose at ambient temperatures.

**POSSIBILITY OF HAZARDOUS REACTIONS:** Hazardous polymerization will not occur.

### SECTION 11 TOXICOLOGICAL INFORMATION

#### INFORMATION ON TOXICOLOGICAL EFFECTS

| Hazard Class                                    | Conclusion / Remarks  |
|---|---|
| <b>Inhalation</b>                               |   |
| Acute Toxicity: No end point data for material. | Minimally Toxic. Based on assessment of the components.   |
| Irritation: No end point data for material.     | Elevated temperatures or mechanical action may form vapors, mist, or fumes which may be irritating to the eyes, nose, throat, or lungs. |



Product Name: MOBIL AERO HFA  
 Revision Date: 01 Oct 2015  
 Page 8 of 12

|  |  |
|--|--|
| <b>Ingestion</b>   |  |
| Acute Toxicity: No end point data for material.                | Minimally Toxic. Based on assessment of the components.  |
| <b>Skin</b>  |  |
| Acute Toxicity: No end point data for material.                | Minimally Toxic. Based on assessment of the components.  |
| Skin Corrosion/Irritation: No end point data for material.     | May dry the skin leading to discomfort and dermatitis. Based on assessment of the components.                  |
| <b>Eye</b>   |  |
| Serious Eye Damage/Irritation: No end point data for material. | May cause mild, short-lasting discomfort to eyes. Based on assessment of the components.                       |
| <b>Sensitization</b>   |  |
| Respiratory Sensitization: No end point data for material.     | Not expected to be a respiratory sensitizer.   |
| Skin Sensitization: No end point data for material.            | Not expected to be a skin sensitizer. Based on assessment of the components.                                   |
| <b>Aspiration:</b> Data available.                             | May be fatal if swallowed and enters airways. Based on physico-chemical properties of the material.            |
| <b>Germ Cell Mutagenicity:</b> No end point data for material. | Not expected to be a germ cell mutagen. Based on assessment of the components.                                 |
| <b>Carcinogenicity:</b> No end point data for material.        | Not expected to cause cancer. Based on assessment of the components.   |
| <b>Reproductive Toxicity:</b> No end point data for material.  | Not expected to be a reproductive toxicant. Based on assessment of the components.                             |
| <b>Lactation:</b> No end point data for material.              | Not expected to cause harm to breast-fed children.   |
| <b>Specific Target Organ Toxicity (STOT)</b>                   |  |
| Single Exposure: No end point data for material.               | Not expected to cause organ damage from a single exposure.   |
| Repeated Exposure: No end point data for material.             | Not expected to cause organ damage from prolonged or repeated exposure. Based on assessment of the components. |

#### TOXICITY FOR SUBSTANCES

| NAME                       | ACUTE TOXICITY                       |
|----------------------------|--------------------------------------|
| 2,6-DI-TERT-BUTYL-P-CRESOL | Oral Lethality: LD50 0.89 g/kg (Rat) |

#### OTHER INFORMATION

##### For the product itself:

Repeated and/or prolonged exposure may cause irritation to the skin, eyes, or respiratory tract. Small amounts of liquid aspirated into the lungs during ingestion or from vomiting may cause chemical pneumonitis or pulmonary edema.

##### Contains:

Base oil severely refined: Not carcinogenic in animal studies. Representative material passes IP-346, Modified Ames test, and/or other screening tests. Dermal and inhalation studies showed minimal effects; lung non-specific infiltration of immune cells, oil deposition and minimal granuloma formation. Not sensitizing in test animals.

The following ingredients are cited on the lists below: None.

--REGULATORY LISTS SEARCHED--



Product Name: MOBIL AERO HFA  
Revision Date: 01 Oct 2015  
Page 9 of 12

1 = NTP CARC  
2 = NTP SUS

3 = IARC 1  
4 = IARC 2A

5 = IARC 2B  
6 = OSHA CARC

## SECTION 12 ECOLOGICAL INFORMATION

The information given is based on data available for the material, the components of the material, and similar materials.

### ECOTOXICITY

Material -- Not expected to be harmful to aquatic organisms.

### MOBILITY

More volatile component -- Highly volatile, will partition rapidly to air. Not expected to partition to sediment and wastewater solids.

Less volatile component -- Low solubility and floats and is expected to migrate from water to the land. Expected to partition to sediment and wastewater solids.

### PERSISTENCE AND DEGRADABILITY

#### Biodegradation:

Components -- Expected to be inherently biodegradable

### BIOACCUMULATION POTENTIAL

Majority of components -- Has the potential to bioaccumulate, however metabolism or physical properties may reduce the bioconcentration or limit bioavailability.

## SECTION 13 DISPOSAL CONSIDERATIONS

Disposal recommendations based on material as supplied. Disposal must be in accordance with current applicable laws and regulations, and material characteristics at time of disposal.

### DISPOSAL RECOMMENDATIONS

Product is suitable for burning in an enclosed controlled burner for fuel value or disposal by supervised incineration at very high temperatures to prevent formation of undesirable combustion products. Protect the environment. Dispose of used oil at designated sites. Minimize skin contact. Do not mix used oils with solvents, brake fluids or coolants.

### REGULATORY DISPOSAL INFORMATION

RCRA Information: The unused product, in our opinion, is not specifically listed by the EPA as a hazardous waste (40 CFR, Part 261D), nor is it formulated to contain materials which are listed as hazardous wastes. It does not exhibit the hazardous characteristics of ignitability, corrosivity or reactivity and is not formulated with contaminants as determined by the Toxicity Characteristic Leaching Procedure (TCLP). However, used product may be regulated.

**Empty Container Warning** Empty Container Warning (where applicable): Empty containers may contain residue and can be dangerous. Do not attempt to refill or clean containers without proper instructions. Empty drums should be



Product Name: MOBIL AERO HFA  
Revision Date: 01 Oct 2015  
Page 10 of 12

completely drained and safely stored until appropriately reconditioned or disposed. Empty containers should be taken for recycling, recovery, or disposal through suitably qualified or licensed contractor and in accordance with governmental regulations. DO NOT PRESSURISE, CUT, WELD, BRAZE, SOLDER, DRILL, GRIND, OR EXPOSE SUCH CONTAINERS TO HEAT, FLAME, SPARKS, STATIC ELECTRICITY, OR OTHER SOURCES OF IGNITION. THEY MAY EXPLODE AND CAUSE INJURY OR DEATH.

|                   |                              |
|-------------------|------------------------------|
| <b>SECTION 14</b> | <b>TRANSPORT INFORMATION</b> |
|-------------------|------------------------------|

**LAND (DOT)**

**Proper Shipping Name:** COMBUSTIBLE LIQUID, N.O.S. (Distillates (Petroleum), Hydrotreated Light)  
**Hazard Class & Division:** COMBUSTIBLE LIQUID  
**ID Number:** NA1993  
**Packing Group:** III  
**ERG Number:** 128  
**Label(s):** NONE  
**Transport Document Name:** NA1993, COMBUSTIBLE LIQUID, N.O.S. (Distillates (Petroleum), Hydrotreated Light), COMBUSTIBLE LIQUID, PG III

Footnote: This material is not regulated under 49 CFR in a container of 119 gallon capacity or less when transported solely by land, as long as the material is not a hazardous waste, a marine pollutant, or specifically listed as a hazardous substance.

**LAND (TDG):** Not Regulated for Land Transport

**SEA (IMDG):** Not Regulated for Sea Transport according to IMDG-Code

**Marine Pollutant:** No

**AIR (IATA):** Not Regulated for Air Transport

|                   |                               |
|-------------------|-------------------------------|
| <b>SECTION 15</b> | <b>REGULATORY INFORMATION</b> |
|-------------------|-------------------------------|

**OSHA HAZARD COMMUNICATION STANDARD:** This material is considered hazardous in accordance with OSHA HazCom 2012, 29 CFR 1910.1200.

**Listed or exempt from listing/notification on the following chemical inventories:** AICS, DSL, ENCS, IECSC, KECI, PICCS, TCSI, TSCA

**EPCRA SECTION 302:** This material contains no extremely hazardous substances.

**SARA (311/312) REPORTABLE HAZARD CATEGORIES:** Fire. Immediate Health. Delayed Health.

**SARA (313) TOXIC RELEASE INVENTORY:** This material contains no chemicals subject to the supplier notification requirements of the SARA 313 Toxic Release Program.



Product Name: MOBIL AERO HFA  
 Revision Date: 01 Oct 2015  
 Page 11 of 12

The following ingredients are cited on the lists below:

| Chemical Name  | CAS Number | List Citations   |
|--|------------|------------------|
| DISTILLATES (PETROLEUM),<br>HYDROTREATED LIGHT             | 64742-47-8 | 1, 17, 18        |
| HYDROTREATED LIGHT<br>NAPHTHENIC DISTILLATE<br>(PETROLEUM) | 64742-53-6 | 1, 4, 13, 17, 18 |
| HYDROTREATED MIDDLE<br>DISTILLATE (PETROLEUM)              | 64742-46-7 | 1, 4, 17, 18     |

--REGULATORY LISTS SEARCHED--

|               |                  |                   |             |
|---------------|------------------|-------------------|-------------|
| 1 = ACGIH ALL | 6 = TSCA 5a2     | 11 = CA P65 REPRO | 16 = MN RTK |
| 2 = ACGIH A1  | 7 = TSCA 5e      | 12 = CA RTK       | 17 = NJ RTK |
| 3 = ACGIH A2  | 8 = TSCA 6       | 13 = IL RTK       | 18 = PA RTK |
| 4 = OSHA Z    | 9 = TSCA 12b     | 14 = LA RTK       | 19 = RI RTK |
| 5 = TSCA 4    | 10 = CA P65 CARC | 15 = MI 293       |             |

Code key: CARC=Carcinogen; REPRO=Reproductive

| SECTION 16 | OTHER INFORMATION |
|------------|-------------------|
|------------|-------------------|

N/D = Not determined, N/A = Not applicable

**KEY TO THE H-CODES CONTAINED IN SECTION 3 OF THIS DOCUMENT (for information only):**

H227: Combustible liquid; Flammable Liquid, Cat 4  
 H304: May be fatal if swallowed and enters airways; Aspiration, Cat 1  
 H400: Very toxic to aquatic life; Acute Env Tox, Cat 1  
 H410: Very toxic to aquatic life with long lasting effects; Chronic Env Tox, Cat 1

**THIS SAFETY DATA SHEET CONTAINS THE FOLLOWING REVISIONS:**

Revision Changes:

Section 01: Company Mailing Address information was modified.

Section 05: Hazardous Combustion Products information was modified.

Section 15: List Citations Table information was modified.

Section 15: National Chemical Inventory Listing information was modified.

Section 14: Marine Pollutant information was modified.

Composition: Component Table information was modified.

Section 08: Exposure Limits Table information was modified.

Section 16: Revision Information - Implementation of GHS requirements phrase. information was deleted.

The information and recommendations contained herein are, to the best of ExxonMobil's knowledge and belief, accurate and reliable as of the date issued. You can contact ExxonMobil to insure that this document is the most current available from ExxonMobil. The information and recommendations are offered for the user's consideration and examination. It is the user's responsibility to satisfy itself that the product is suitable for the intended use. If buyer repackages this product, it is the user's responsibility to insure proper health, safety and other necessary information is included with and/or on the container. Appropriate warnings and safe-handling procedures should be provided to handlers and users. Alteration of this document is strictly prohibited. Except to the extent required by law,



Product Name: MOBIL AERO HFA  
Revision Date: 01 Oct 2015  
Page 12 of 12

---

re-publication or retransmission of this document, in whole or in part, is not permitted. The term, "ExxonMobil" is used for convenience, and may include any one or more of ExxonMobil Chemical Company, Exxon Mobil Corporation, or any affiliates in which they directly or indirectly hold any interest.

---

Internal Use Only

MHC: 2A, 0, 0, 0, 1, 1

PPEC: C

DGN: 2005454XUS (552975)

---

Copyright 2002 Exxon Mobil Corporation, All rights reserved



## **APPENDIX III**

### **Declaration of Conformity**





## DECLARATION of CONFORMITY

The design, development and manufacture is in accordance with European Community guidelines

Axle Jack  
02-7862C0100

Relevant provisions complied with by the machinery:  
2006/42/EC

Relevant standards complied with by the machinery:  
EN ISO 12100-1

Identification of person empowered to sign on behalf of the Manufacturer:

A handwritten signature in cursive script that reads "Patrick Finch". The signature is written in black ink and is positioned above a horizontal line.

Quality Assurance Representative





## **APPENDIX IV**

### **Maintenance Schedule**





## Maintenance Schedule

### Axle Jacks

Tronair recommends performing preventative maintenance on all jacks, which should include a 90-day routine inspection and a 12-month load test.

Model Number \_\_\_\_\_ Serial Number \_\_\_\_\_

Maintenance Performed By \_\_\_\_\_ Date \_\_\_\_\_

#### 90-Day Maintenance:

- Check hydraulic system for leaks including the following:
  - Hand pump; cylinder, fittings and seals
  - Reservoir; welds and fittings
- Check jack structure for corrosion, bending, cracking and excessive wear including the following:
  - Base plate
  - Mechanical extension
  - Hydraulic cylinder assembly
  - Retaining ring (secures the cylinder to the base plate)
  - Jack pads, nose and main gear adapters
  - Spacer blocks
- Check fluid level with rams fully retracted. See manual for proper level height
- Extend rams and visually inspect for corrosion, foreign matter, excessive wear and leaks around ram seals. Remove any foreign matter
- Check paint condition, touch-up areas that are exposed
- Actuate the hand pump and raise the ram to full extension at least once.  
**Do not** pressurize hydraulic system once fully extended  
**Do not** allow jack to miss-stage when raising the rams to full extension
- Extend rams and visually inspect for corrosion, foreign matter, excessive wear and leaks around ram seals. Remove any foreign matter
- Open release valve and verify that rams fully retract

#### Annual (12-Month) Maintenance:

- Check hydraulic fluid for contamination (dirt/water) drain and flush if required
- Perform 90-day maintenance checklist
- Capacity test (110% of jack's rated capacity)

**NOTE:** The jack may be returned to Tronair for load testing, or sent to a local hydraulic repair shop. Please contact Tronair to obtain a "Return Material Authorization Number" (RMA #) before sending any product to Tronair.

the Tronair group of companies:

[www.tronair.com](http://www.tronair.com) | [www.columbusjack.com](http://www.columbusjack.com) | [www.daeind.com](http://www.daeind.com) | [www.datcomedia.com](http://www.datcomedia.com) | [www.eagletugs.com](http://www.eagletugs.com) | [www.malabar.com](http://www.malabar.com)