

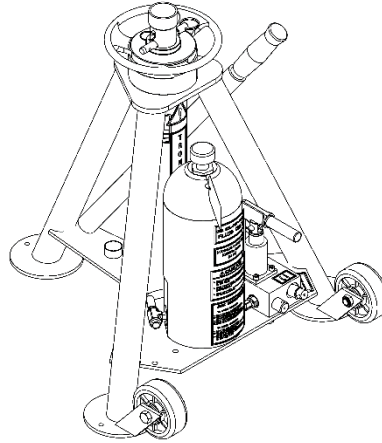

# OPERATION & SERVICE MANUAL



## Models:

02-0527C0140, 02A0527C0140, 02C0527C0140,  
02-7827C0110, 02A7827C0110

**5 Ton (4.5 Metric Ton)  
Two Stage Jack**



08/2024 – Rev. 09

The Tronair Group of Companies: Tronair | EBIS | Columbus Jack | Eagle | DAE | Malabar International

**Tronair, Inc.**  
1 Air Cargo Pkwy East  
Swanton, OH 43558

Phone: (419) 866-6301 | 800-426-6301  
Web: [www.tronair.com](http://www.tronair.com)  
Email: [sales@tronair.com](mailto:sales@tronair.com)

REVISION	DATE	TEXT AFFECTED
07	07/2021	Modified Parts Lists
08	07/2022	Modified 6.2 Numerical Values and 7.6 Storage Space and Handling Facilities
09	08/2024	Modified Parts List



## TABLE OF CONTENTS

	<u>PAGE</u>
<b>1.0 PRODUCT INFORMATION .....</b>	<b>1</b>
1.1 DESCRIPTION.....	1
1.2 MODEL & SERIAL NUMBER.....	1
1.3 MANUFACTURED .....	1
1.4 USAGE .....	1
<b>2.0 SAFETY INFORMATION .....</b>	<b>1</b>
2.1 USAGE AND SAFETY INFORMATION .....	1
2.2 WARNING AND DANGER SIGNS.....	1
2.3 COMPONENT SAFETY FEATURES.....	1
2.4 FUNCTIONAL SAFETY FEATURES .....	1
2.5 FEATURES FOR OPERATOR SAFETY .....	1
2.6 ENVIRONMENTAL SAFETY FEATURES .....	2
2.7 NECESSARY PERSONAL PROTECTIVE EQUIPMENT .....	2
2.8 SAFETY GUIDELINES .....	2
2.9 CONDITIONS FOR SAFE USE .....	2
2.10 OPERATOR QUALIFICATIONS .....	2
2.11 ADDITIONAL SAFETY MEASURES.....	2
2.12 IN CASE OF HYDRAULIC FAILURE .....	2
<b>3.0 TRAINING .....</b>	<b>2</b>
3.1 TRAINING REQUIREMENTS .....	2
3.2 TRAINING PROGRAM .....	2
3.3 OPERATOR TRAINING .....	2
<b>4.0 ASSEMBLY .....</b>	<b>3</b>
4.1 GENERAL INSTRUCTIONS .....	3
4.2 PRE-USE CHECKS .....	3
4.3 PERSONNEL REQUIREMENTS .....	3
4.4 INSPECTION AND TEST PROCEDURES .....	3
<b>5.0 INSTALLATION .....</b>	<b>3</b>
5.1 AIR SUPPLY REQUIREMENTS .....	3
<b>6.0 OPERATION .....</b>	<b>4</b>
6.1 OPERATING PARAMETERS .....	4
6.2 NUMERICAL VALUES .....	4
6.3 OPERATOR CONTROLS .....	4
6.4 OPERATING INSTRUCTIONS .....	4
6.4.1 Rules For Operating.....	5
6.4.2 Jack Instructions .....	5
<b>7.0 PACKAGING AND STORAGE .....</b>	<b>8</b>
7.1 PACKAGING REQUIREMENTS .....	8
7.2 HANDLING .....	8
7.3 STRAPPING .....	8
7.4 LABELING OF PACKAGING .....	8
7.5 STORAGE ENVIRONMENT .....	8
7.6 STORAGE SPACE AND HANDLING FACILITIES .....	8
<b>8.0 TRANSPORTATION.....</b>	<b>8</b>
<b>9.0 TROUBLE SHOOTING .....</b>	<b>8</b>
<b>10.0 MAINTENANCE .....</b>	<b>9</b>
10.1 GENERAL .....	9
10.2 MAINTENANCE SCHEDULE.....	9
10.2.1 Storage/Low Usage.....	9
10.3 SERVICING JACK .....	9
10.4 REMOVING AND SERVICING PUMP .....	9
10.5 JACK FUNCTION LOAD TEST.....	9
10.6 PNEUMATIC PUMP .....	9
<b>11.0 PROVISION OF SPARES.....</b>	<b>10</b>
11.1 SOURCE OF SPARE PARTS.....	10
11.2 RECOMMENDED SPARE PARTS LISTS .....	10
<b>12.0 IN SERVICE SUPPORT.....</b>	<b>10</b>
<b>13.0 GUARANTEES/LIMITATION OF LIABILITY .....</b>	<b>10</b>
<b>14.0 APPENDICES .....</b>	<b>10</b>



This product can not be modified without the written approval of Tronair, Inc. Any modifications done without written approval voids all warranties and releases Tronair, Inc., its suppliers, distributors, employees, or financial institutions from any liability from consequences that may occur. Only Tronair OEM replacement parts shall be used.

## 1.0 PRODUCT INFORMATION

### 1.1 DESCRIPTION

5 Ton Two Stage Jack

02-0527C0140, 02-7827C0110 ..... Standard  
 02A0527C0140, 02A7827C0110 .....with Air Pump Option  
 02C7827C0110 .....with Spring Loaded Casters

### 1.2 MODEL & SERIAL NUMBER

Reference nameplate on unit

### 1.3 MANUFACTURED

**TRONAIR, Inc.**

1 Air Cargo Pkwy East  
 Swanton, Ohio 43558 USA

Telephone: (419) 866-6301 or 800-426-6301

Fax: (419) 867-0634

E-mail: sales@tronair.com

Website: www.tronair.com

### 1.4 USAGE

The device is intended to lift an aircraft by its fuselage and/or main wing with other hydraulic jacks arranged by position and quantity to provide proper balance, and in conjunction with the correct jack pad, whose maximum load on any one jack does not exceed the rated capacity of the jack.

The jacks are not intended for metal forming, metal working, or any purpose other than that stated above.

## 2.0 SAFETY INFORMATION

### 2.1 USAGE AND SAFETY INFORMATION

To insure safe operations please read the following statements and understand their meaning. Also refer to your equipment manufacturer's manual for other important safety information. This manual contains safety precautions which are explained below. Please read carefully.



**WARNING!** — Warning is used to indicate the presence of a hazard that **can cause severe personal injury, death, or substantial property damage** if the warning notice is ignored.

**CAUTION!** — Caution is used to indicate the presence of a hazard that **will or can cause minor personal injury or property damage** if the caution notice is ignored.

### 2.2 WARNING AND DANGER SIGNS

See labels on unit.



**WARNING!**

**The ram locknuts are user operated safety devices. Failure to utilize these locknuts may result in personal injury or death.**

### 2.3 COMPONENT SAFETY FEATURES

- **Ram Locknut** prevents lowering of the ram. The Ram Locknut must be lowered as the aircraft is being lifted.
- **Hold To Run Air Valve** requires the operator to hold the air lever to raise the ram using the air pump. Releasing the air valve stops upward movement of the ram.
- **CE Hand Pump With Check Valve** prevents unintentional decent of aircraft if relief valve fails.
- **Locknut Retention Ring** prevents locknut from being unscrewed from 2<sup>nd</sup> stage ram

### 2.4 FUNCTIONAL SAFETY FEATURES

**Pressure Relief Valve** prevents overload during raising operations.

### 2.5 FEATURES FOR OPERATOR SAFETY

- Hold to Run Air Valve
- Air Shut Off Valve
- Cautions and Instruction Labels Located on Jack
- Ram Locknut

**2.6 ENVIRONMENTAL SAFETY FEATURES**

The jack is non-polluting. See Appendix V for Material Safety Data concerning the recommended hydraulic fluid (MIL-PRF-5606).

**2.7 NECESSARY PERSONAL PROTECTIVE EQUIPMENT****CAUTION!**

**Always wear safety glasses.**

**2.8 SAFETY GUIDELINES****CAUTION!**

**Do not place hands on top of jack near ram locknuts while lowering jack. Pinch points exist between top of jack and threads on ram.**

1. **NEVER** put hands between the aircraft and the jack pad; as after aircraft has been lowered, struts may have hung up.
2. **NEVER** align jack under aircraft by pounding on jack legs. Dented legs may lead to jack collapse.
3. **ALWAYS** lower ram lock nut(s) after jack is under load. Be sure ram nut(s) is seated fully after jacking.
4. **ALWAYS** raise and lower jacks simultaneously so that aircraft remains level.
5. **ALWAYS** use a tail or nose stand, as applicable, for additional stability.

**WARNING!**

**The ram locknuts are user operated safety devices. Failure to utilize these locknuts may result in personal injury or death.**

**2.9 CONDITIONS FOR SAFE USE**

- Use in a clean dry environment on a level surface.
- Operate between -20° C and 50°C (-4° F and 122° F).

**2.10 OPERATOR QUALIFICATIONS**

This jack is intended to be used by the skilled and trained aircraft technician. The operator must be familiar with the jacking procedures for the aircraft to be raised, and the operation of the jack.

**Installation/Maintenance/Dismantling Qualifications:** This jack is to be installed, maintained, and dismantled by qualified technicians familiar with hydraulic systems.

**2.11 ADDITIONAL SAFETY MEASURES**

This jack must be used in accordance with this technical manual, and in accordance with the aircraft manufacturer's jacking procedures.

**2.12 IN CASE OF HYDRAULIC FAILURE**

Proper use of the ram locknuts will prevent lowering of the ram. To prevent unintentional descent ram locking nuts must be kept within 2 inches of the stop while raising the jack.

**3.0 TRAINING****3.1 TRAINING REQUIREMENTS**

The employer of the operator is responsible for providing a training program sufficient for the safe operation of the unit.

**3.2 TRAINING PROGRAM**

The employer provided operator training program should cover safety procedures concerning use of the unit in and around the intended aircraft at the intended aircraft servicing location.

**3.3 OPERATOR TRAINING**

The operator training should provide the required training for safe operation of the unit.

**NOTE: Maintenance and Trouble Shooting are to be performed by a skilled and trained technician.**



#### 4.0 ASSEMBLY

This product is shipped completely assembled and tested and requires no further assembly before operation. The following sections apply when servicing the unit.

#### 4.1 GENERAL INSTRUCTIONS

1. This product should be assembled and/or repaired using good workmanship practices and proper tools. Bolts and elastic stopnuts should be tightened to a torque not to exceed industry standards for Grade '5' bolts.
2. All replacement parts must be the same as or better than the original parts supplied.
3. Dispose of waste per federal and local laws and regulations.
4. No modifications are allowed that will adversely affect the jacks safety performance.
5. The pressure relief valve is not serviceable. It must be replaced as a unit.

#### 4.2 PRE-USE CHECKS

1. Refer to the Illustrated Parts List to identify and ensure that all parts are present.
2. Generally, check over unit to assure the tightness of all nuts, bolts and fittings.
3. With rams completely collapsed, check hydraulic fluid level.
  - Replenish with MIL-PRF-5606 fluid as required.
  - **Fluid Level:** 1.5 in (3.8 cm) below vent.

**NOTE: Refer to fluid manufacturer's (Appendix) Material Safety Data Sheet, and advisory for handling and disposal of fluid.**

#### 4.3 PERSONNEL REQUIREMENTS

This jack is to be assembled by qualified technicians familiar with hydraulic systems.

#### 4.4 INSPECTION AND TEST PROCEDURES

1. Ensure fluid level is within 1.5 inches (3.8 cm) from reservoir vent cap.
2. Raise ram to full stroke, and check for leaks.

#### 5.0 INSTALLATION

Installation and commissioning requires connection of the air valve to an adequate air supply (Air Pump equipped Models only).

#### 5.1 AIR SUPPLY REQUIREMENTS

- 25 psi (1.72 bar) Minimum
- 40 psi (2.75 bar) Recommended
- 125 psi (8.60 bar) Maximum

**6.0 OPERATION****6.1 OPERATING PARAMETERS**

- The user shall work in accordance with the Operator Manual.
- At no time shall personnel work under the raised load until it is secured by suitable means, i.e. ram locknut.
- The employer of the operator shall provide for all necessary training and give information about pumping and translating forces.
- Operate between -20° C and 50°C (-4° F and 122° F).

**6.2 NUMERICAL VALUES**

Rated Capacity.....	10,000 lbs (4,536 kg)
Minimum Closed Height.....	27-3/8 in (69.5 cm)
Mechanical Extension.....	9 in (22.9 cm)
Hydraulic Extension.....	34 in (87.5 cm)
Maximum Height Obtainable.....	70-13/16 in (179.9 cm)
Weight	
02-0527C0140, 02-7827C0110.....	129 lbs (58.7 kg)
02A0527C0140, 02Z7827C0110.....	177.5 (80.5 kg)
02C0527C0140.....	172.9 (78.4 kg)
Pressure Relief Setting.....	2,500 +250/-0 psig (172.4+17.2/-0 bar)
Noise level is 64 dB(A) at a distance of 120 in (304.8 cm) at an inlet pressure of 100 psi (6.9 bar)	

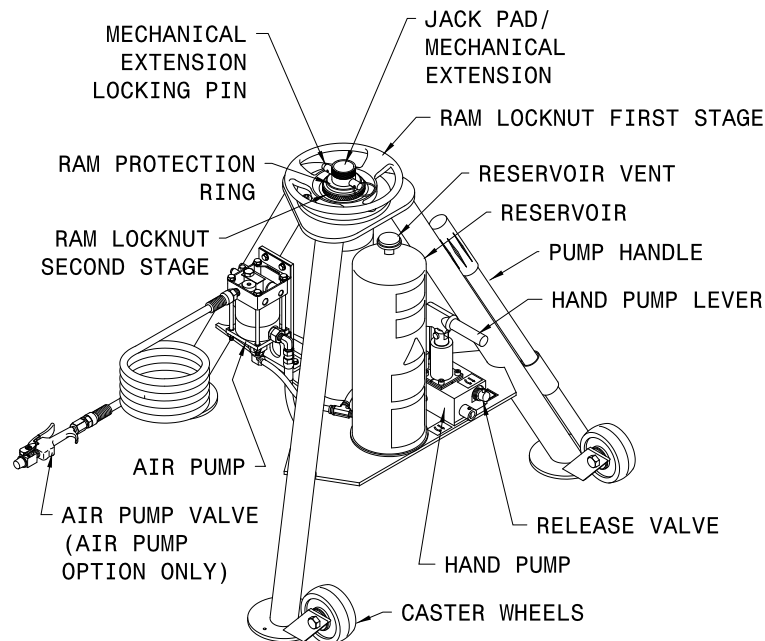
**6.3 OPERATOR CONTROLS****6.4 OPERATING INSTRUCTIONS**

The user should be familiar with the following statements prior to using the jack(s):

**CAUTION!**

1. **NEVER** put hands between the aircraft and the jack pad; as after aircraft has been lowered, struts may have hung up.
2. **NEVER** align jack under aircraft by pounding on jack legs. Dented legs may lead to jack collapse.
3. **ALWAYS** lower ram locking nut(s) after jack is under load. Be sure ram nut(s) is seated fully after jacking.
4. **ALWAYS** raise and lower jacks simultaneously so that aircraft remains level.
5. **ALWAYS** use a tail or nose stand, as applicable, for additional stability.

**WARNING!**

When collapsing rams by hand miss-staging may occur and cause pinch points. To collapse ram, add a minimum 50 lb load to the mechanical extension. Keep hands and fingers clear of locking nuts. Failure to adhere to this safety instruction can cause injury.

## 6.4.1 Rules For Operating

1. The user shall work in accordance with the Operator and/or Technical Manuals.
2. At no time shall personnel work under the raised load until it is secured by suitable means, i.e. ram locknut.
3. The employer of the operator shall provide for all necessary training and give information about pumping and translating forces.
4. Operate between -20° C and 50°C/-4° F and 122° F.

## 6.4.2 Jack Instructions

**To Raise Aircraft:**

1. Place jack on a hard, level surface.
2. Hydraulic rams must be completely retracted before operating jack.
3. Raise mechanical extension as close to aircraft jack pad as possible.

**WARNING!**

The locking pin **MUST** be placed in the ram protection ring groove and fully through the mechanical extension.

The locking pin washer and ball lock **MUST** be placed outside the ram protection ring.

- Visually inspect the jack prior to every use.
- Do not place extra locking pins in any other hole on the mechanical extension.
- Insure mating surfaces to jack point are free of debris and damage.
- Under no conditions should the locking pin washer or washer groove be inside the ram protection ring groove.
- Under no conditions should the locking pin's ball lock be inside the ram protection ring groove.
- Never use the jack if the ram protection ring is not installed.
- Never use the locking pin without a locking pin washer.
- Never use a locking pin that has been damaged.
- Never use a ram protection ring that has been damaged or deformed.
- Replace ram protection ring if it does not have a radius groove for the locking pin.
- Load test jacks annually.
- Only order replacement parts from Tronair.
- Failure to comply could result in premature failure below certified weight and could cause serious injury including death.

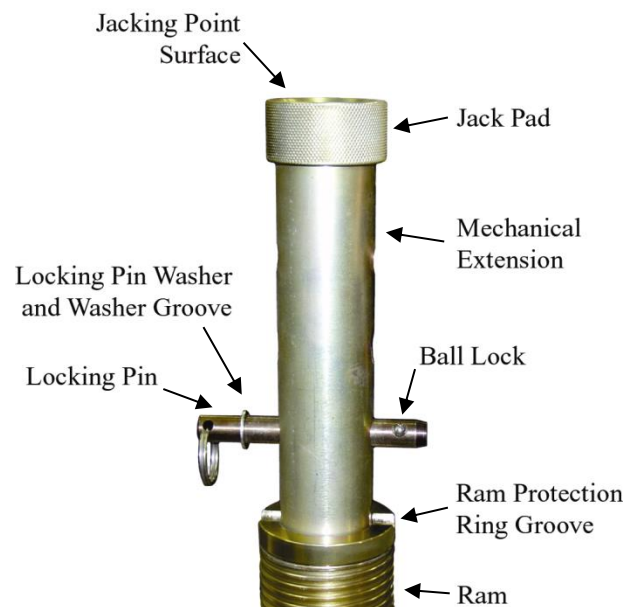

6.4.2 Jack Instructions (continued)

**Correct Pin Placement**

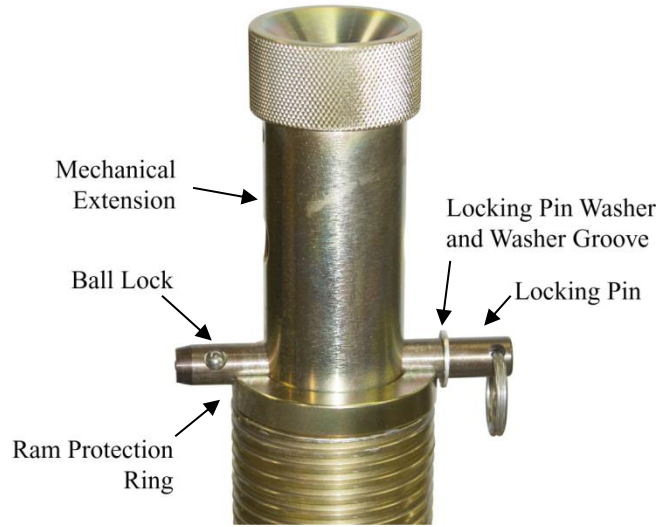

**Incorrect Pin Placements**



Washer In Ram Protection Ring

Ball Lock In Ram Protection Ring

Washer On Top Of Ram Protection Ring

Locking Pin Not In Ram Protection Ring and top Locking Pin in Mechanical Extension (use only one pin)

**Results Of Locking Pin In Incorrect Location**

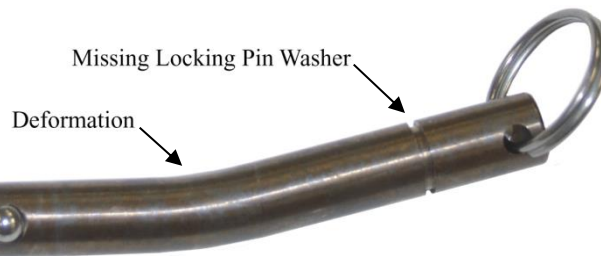

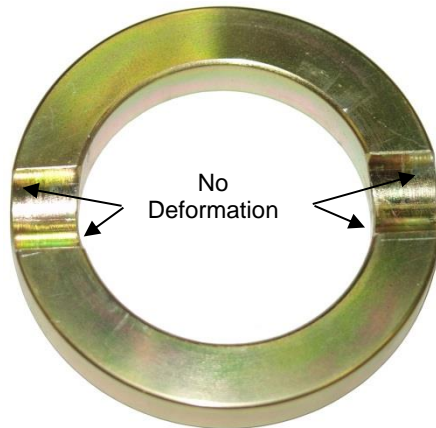
6.4.2 Jack Instructions (*continued*)**Ram Protection Ring**

Acceptable Condition

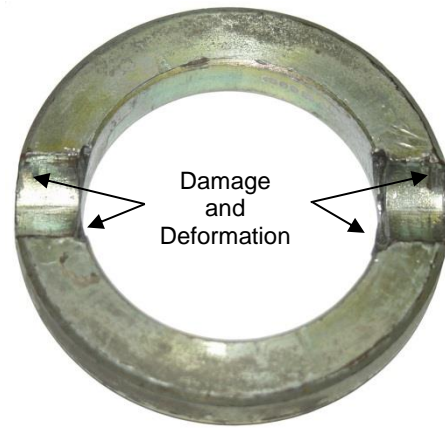

Unacceptable Condition

4. Close pump release valve by turning clockwise.

**Note:** Turning the pump release valve counter-clockwise lowers the jack. Turning the pump release valve clockwise stops the jack's descent, and allows it to be raised.

5. Hydraulic rams must extend in order from largest to smallest diameter.
6. Lower ram locknut(s) as aircraft is raised. Keep locknuts within 1 inch from bottom of extending ram.
7. Largest diameter hydraulic ram must fully extend before the next stage ram begins to rise.
8. Do not continue to operate hand pump after all rams have fully extended.

**WARNING!**

- The ram locknuts are user operated safety devices. Failure to utilize these locknuts may result in personal injury or death.
- Do not place hands on top of jack near ram locknuts while lowering jack. Pinch points exist between top of jack and threads on ram.
- Always wear safety glasses.

**To Lower Aircraft:**

1. Lower all jacks simultaneously.
2. If ram locknut(s) is tight, raise jack slightly to release nut(s) ¼ inch from tripod.
3. Ensure proper staging as aircraft is being lowered: loosen ram locknut beginning with smallest ram (1" max) until stage is completely lowered. Repeat for next largest stage.
4. Loosen pump release valve slightly to slowly lower aircraft.

**NOTE:** When using jack during washing operations, completely cover top of jack near ram seal.



## 7.0 PACKAGING AND STORAGE

### 7.1 PACKAGING REQUIREMENTS

Jacks are to be packaged as required to prevent damage to legs or hydraulic equipment during shipment.

### 7.2 HANDLING

Jacks can be rolled by hand on its casters.

### 7.3 STRAPPING

Jacks can be strapped down by suitable means to prevent unwanted movement during shipment.

### 7.4 LABELING OF PACKAGING

Packaging should be labeled **DO NOT DROP**.

### 7.5 STORAGE ENVIRONMENT

- Store jacks between -20°C and +50°C/-4° F and 122° F.
- Always store jack with ram all the way down.
- Suitable for outdoor storage by using a full coverage waterproof tarp or canvas.

### 7.6 STORAGE SPACE AND HANDLING FACILITIES

Minimum Closed Height .....	27-3/8 in (69.5 cm)
Mechanical Extension .....	9 in (22.86 cm)
Hydraulic Extension.....	34 in (86.36 cm)
Maximum Height Obtainable .....	70-13/16 in (179.9 cm)
Weight	
02-0527C0140, 02-7827C0110.....	129 lbs (58.7 kg)
02A0527C0140, 02Z7827C0110.....	177.5 (80.5 kg)
02C0527C0140 .....	172.9 (78.4 kg)

## 8.0 TRANSPORTATION

Lifting can be accomplished by crane and strap thru top of tripod, or by fork truck under lower tripod support. Approximate weight is 108 lbs (48.99 kg).

## 9.0 TROUBLE SHOOTING

TROUBLE	PROBABLE CAUSE	ACTION
Fluid leakage at pump piston or pump body	Damaged backup ring, o-ring, piston or pump body	Remove piston and pump body. Inspect for damage. Replace defective part(s). Replace removed o-ring and backup ring
External fluid leakage at rams	Damaged o-ring, backup ring or inner cylinder wall.	Remove rams as a unit from cylinder. Inspect parts. Replace o-ring and defective part(s)
Jack fails to lift rated load	Release valve not closed properly	Fully tighten release valve
	Low fluid level	Fill to correct fluid level
	Pressure relief valve improperly adjusted	Adjust or replace release valve
	Leakage at inlet or outlet check ball	Inspect valve body for wear or replace valve body and check balls
Rams will not support load after manual or pneumatic pump up	Vent screw closed	Open vent screw
	Leaking ram o-ring seals	Check for external leakage, if present replace defective seal and back up ring
	Leaking pressure check valve	Inspect valve body for wear or replace valve body and check balls
Rams raise and fall with each manual pump stroke	Leaking pressure relief valve	Remove release valve, inspect ball and ball seat in pump block. Replace effective part(s)
	Release valve open	Fully tighten release valve
	Inlet check valve not seated or sticking	Pump rapidly to dislodge or replace valve body
Jack fails to lower	Pressure check valve not seated or sticking	Pump rapidly to dislodge or replace valve body
	Ram locknut not loosened	Raise jack ¼ inch and release locknut
	Vent screw closed	Open vent screw
	O-Ring (pinched or rolled)	Replace o-ring and back-up ring, clean up cylinder wall of debris



## 10.0 MAINTENANCE

### 10.1 GENERAL

- All maintenance and/or repair work should be done using good workmanship practices and proper tools.
- The work area should be clean and free of dirt.
- When O-rings and backup rings are removed, every effort should be made to avoid the contact of tools with the critical surfaces of parts. Surface deformities could cause degradation of seals and failure.
- It is good practice to replace both O-rings and backup rings once removed. Cut and damaged rings normally result in fluid leakage.
- At this time flush old hydraulic fluid and dirt from over-all system and replenish with new, clean hydraulic fluid.
- No modifications shall be carried out without prior written approval by Tronair.

### 10.2 MAINTENANCE SCHEDULE

Check Fluid Level.....	Each Use
Lubricate Casters .....	3 Months
Cleaning .....	Annually Or As Needed
Capacity Test (105%-110% of jack's rated capacity) .....	Annually

**NOTE: Wipe with soft cloth only, do no pressure wash or spray water directly at ram seal.**

#### 10.2.1 Storage/Low Usage

If jack is not being used on a regular basis, every 90 days the jack should be fully extended and retracted to exercise the seals and to prevent rust build up on the cylinder I.D. While ram is extended, clean the threads and spray with DoALL RPM, LPS, or equivalent that is water repellent and will not harm BUNA "N" O-rings.

### 10.3 SERVICING JACK

#### To Disassemble Jack For Seal Replacement:

1. Raise first stage ram high enough to allow removal of the threaded tube stop.
2. Raise both first and second stage rams **together** to the point where this assembly can be lifted from the jack cylinder.

**NOTE: If the second stage ram is allowed to precede the first stage ram, it will fill with oil causing an oil spill when the assembly is removed from the cylinder.**

#### To Re-assemble Jack:

1. Re-assemble in reverse order of above.

#### NOTE: Lubricate cylinder, ram(s) and o-ring(s) for assembly:

Lubricate inner cylinder wall(s) with MIL-PRF-5606 hydraulic fluid

Apply suitable o-ring lubricant grease to installed o-ring(s) and to o-ring lead-in chamfer at opening of cylinder

**NOTE: To minimize air entrapment under the rams. Actuate cylinder with had pump several inches and release. This will circulate oil and bleed out air.**

2. Spray I.D. of cylinder and O.D. of rams with DoALL RPM, LPS or equivalent water repellent that will not harm the Buna "N" O-rings to protect surfaces from rusting when not in use.
3. Ensure locknut retaining ring is present on second stage ram to prevent nut removal after seal kit installation.

**NOTE: Dispose of hydraulic fluid per local and federal regulations.**

### 10.4 REMOVING AND SERVICING PUMP

**Note: If pump is found faulty, call the factory for replacement.**

1. Clamp suction (push on) hose and remove hose from pump.
2. Uncouple fitting of hydraulic hoses from pump.
3. Remove pump from jack.
4. Re-assemble in reverse order.

### 10.5 JACK FUNCTION LOAD TEST

**NOTE: If function load testing is required:**

1. Take all necessary precautions to prevent injury.
2. Always jack against a load and never against the jack itself.
3. Do not exceed a test load equal to the jack rated capacity plus 5% to 10%.

### 10.6 PNEUMATIC PUMP

See Appendix II Haskel Air Pump Manufacturer Data for complete parts list and repair information.



**11.0 PROVISION OF SPARES**

**11.1 SOURCE OF SPARE PARTS**

Spare parts may be obtained from the manufacturer:

<b>TRONAIR</b> , Inc.	Telephone: (419) 866-6301 or 800-426-6301
1 Air Cargo Pkwy East	Fax: (419) 867-0634
Swanton, Ohio 43558 USA	E-mail: sales@tronair.com
	Website: www.tronair.com



For Spare Parts, Operations & Service Manuals or Service Needs:  
 Scan the QR code or visit Tronair.com/aftermarket

**11.2 RECOMMENDED SPARE PARTS LISTS**

Reference the following page(s) for Replacement Parts and Kits available.

Recommended Spares to be kept on hand:

- K-4588.....Kit, Ram Seal Replacement
- K-3441.....Kit, Pump Seal Replacement
- K-1685.....Kit, Repair Fluid Seal (Air Option only)
- K-1686.....Kit, Repair Air Seal (Air Option only)

**12.0 IN SERVICE SUPPORT**

Contact Tronair, Inc. for technical services and information. See Section 1.3 – Manufacturer.

**13.0 GUARANTEES/LIMITATION OF LIABILITY**

Tronair products are warranted to be free of manufacturing or material defects for a period of one year after shipment to the original customer. This is solely limited to the repair or replacement of defective components. This warranty does not cover the following items:

- a) Parts required for normal maintenance
- b) Parts covered by a component manufacturers warranty
- c) Replacement parts have a 90-day warranty from date of shipment

If you have a problem that may require service, contact Tronair immediately. Do not attempt to repair or disassemble a product without first contacting Tronair, any action may affect warranty coverage. When you contact Tronair be prepared to provide the following information:

- a) Product Model Number
- b) Product Serial Number
- c) Description of the problem

If warranty coverage is approved, either replacement parts will be sent or the product will have to be returned to Tronair for repairs. If the product is to be returned, a Return Material Authorization (RMA) number will be issued for reference purposes on any shipping documents. Failure to obtain a RMA in advance of returning an item will result in a service fee. A decision on the extent of warranty coverage on returned products is reserved pending inspection at Tronair. Any shipments to Tronair must be shipped freight prepaid. Freight costs on shipments to customers will be paid by Tronair on any warranty claims only. Any unauthorized modification of the Tronair products or use of the Tronair products in violation of cautions and warnings in any manual (including updates) or safety bulletins published or delivered by Tronair will immediately void any warranty, express or implied.

The obligations of Tronair expressly stated herein are in lieu of all other warranties or conditions expressed or implied. **Any unauthorized modification of the Tronair products or use of the Tronair products in violations of cautions and warnings in any manual (including updates) or safety bulletins published or delivered by Tronair will immediately void any warranty, express or implied and Tronair disclaims any and all liability for injury (WITHOUT LIMITATION and including DEATH), loss or damage arising from or relating to such misuse.**

**14.0 APPENDICES**

- APPENDIX I Hydraulic Schematic
- APPENDIX II Haskel Air Pump Manufacturer Data
- APPENDIX III Safety Data Sheet – MIL-PRF-5606 Hydraulic Fluid
- APPENDIX IV Declaration of Conformity
- APPENDIX V Maintenance Schedule

### Parts List

When ordering replacement parts/kits, please specify model, serial number and color of your unit.

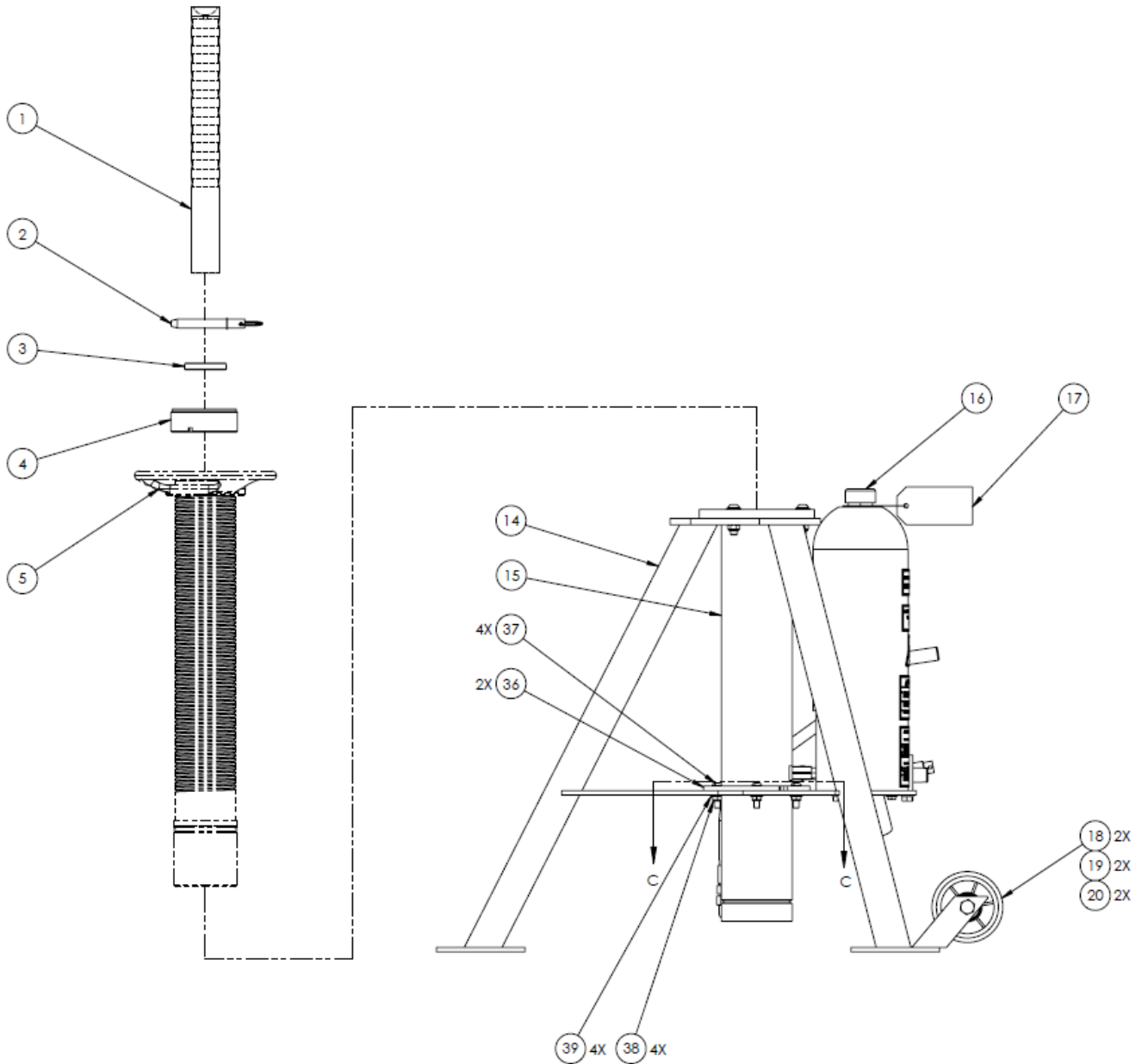

**Parts List**

When ordering replacement parts/kits, please specify model, serial number and color of your unit.

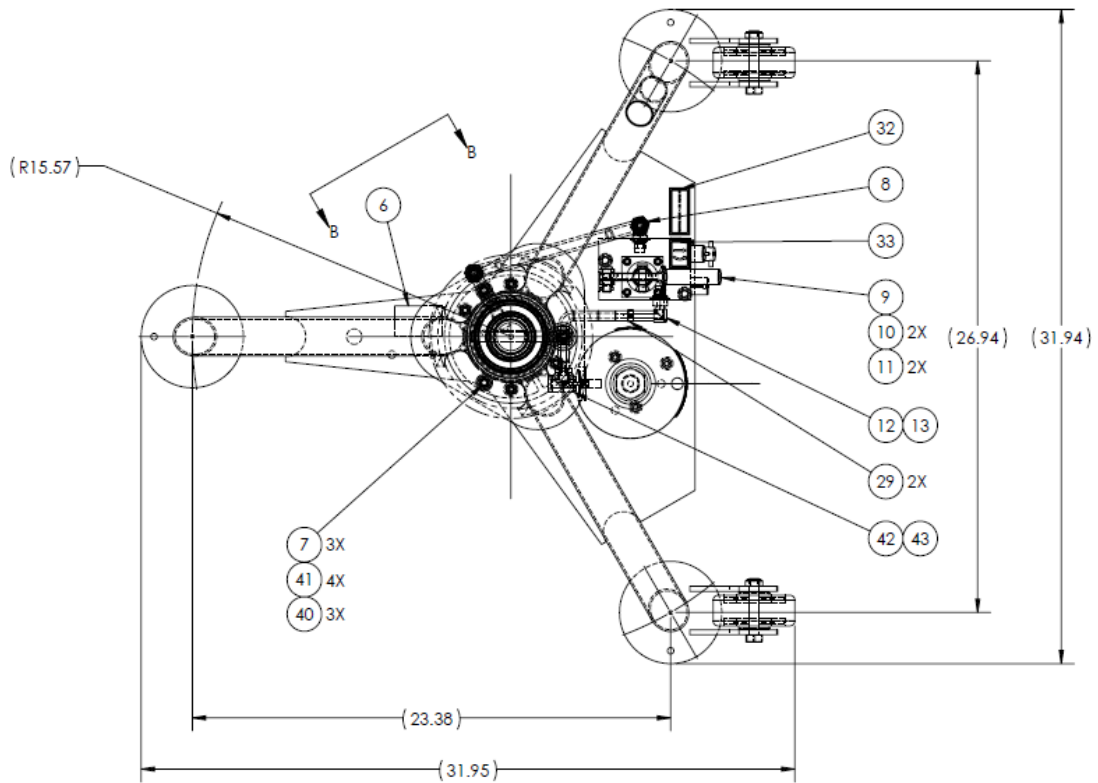
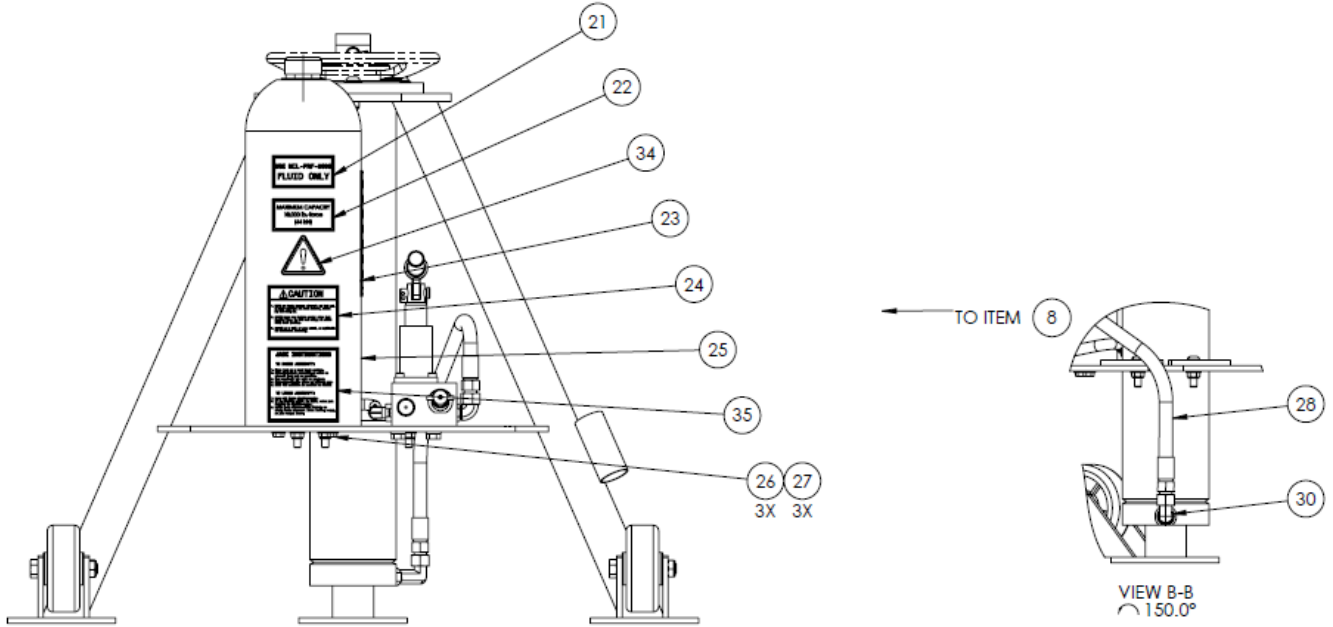



## Parts List

When ordering replacement parts/kits, please specify model, serial number and color of your unit.

Item	Part Number	Description	Qty
1	R-1013-03	EXTENSION, CENTER	1
2	G-1318-0825	PIN, 1/2 MODEL D	1
3	TR-1026	RING, RAM PROTECTION	1
4	TR-2222	TUBE, STOP	1
5	Z-7685-02	ASSEMBLY, RAM	1
6	V-1001	LABEL, MADE IN USA	1
7	G-1154-107214	SCREW, 3/8-16 X 1-1/2" LG. SOCKET BUTT HD CAP	3
8	N-2001-08-S-B	ELBOW, STRAIGHT THREAD	1
9	HC-2764	PUMP, HAND	1
10	G-1100-107010	BOLT, 3/8-16 X 1.0" HEX HD GR 5	2
11	G-1251-1070R	LOCKWASHER, 3/8 REGULAR	2
12	N-2788-02-S-B	ELBOW, 1/4 HOSE, -06 SAE	1
13	TF-1047-01-05.0	HOSE, PUSH-ON, Ø 1/4 ID X 5 LONG	1
14	Z-1767-00	WELDMENT, TRIPOD	1
15	Z-7678-02-01	WELDMENT, TUBE/BASE	1
16	H-1045	BREATHER	1
17	V-1807	TAG, RESERVOIR FILL	1
18	U-1002	WHEEL	2
19	G-1203-1095	JAMNUT, 1/2-20 ELASTIC	2
20	G-1100-109526	BOLT, 1/2-20 X 2-3/4" HEX HD GR 5	2
21	V-1102	LABEL, MIL-PRF-5606	1
22	V-1016	LABEL, MAX CAPACITY - 10K	1
23	V-1198	LABEL, TRONAIR	1
24	V-1819	LABEL, HYD JACK CAUTION	1
25	HC-2329	RESERVOIR, TRANSLUCENT 1.25 GALLONS	1
26	G-1100-105006	BOLT, 1/4-20 X 3/4" LG HEX HD GR 5	3
27	G-1250-1050N	FLATWASHER, 1/4 NARROW	3
28	TF-1043-03-21.0	ASSEMBLY, HOSE X 21 LONG	1
29	H-1516-08	CLAMP, 2-EAR HOSE	2
30	N-2706-02-S-B	ELBOW, LONG STR THD	1
32	V-1775	LABEL, PUMP FORCE	1
33	V-1776	LABEL, DOWN	1
34	V-1805	LABEL, ISO GENERAL DANGER	1
35	V-1820	LABEL, HYD JACK INSTRUCT	1
36	J-4982	RETAINING RING, CYLINDER	2
37	G-1154-106212	SCR, 5/16-18 SOC BUT HD CP	4
38	G-1202-1060	STOPNUT, 5/16-18 ELASTIC	4
39	G-1250-1060N	FLATWASHER, 5/16 NARROW	4
40	G-1202-1070	STOPNUT, 3/8-16 ELASTIC	3
41	G-1250-1070N	FLATWASHER, 3/8 NARROW	4
42	N-2660-01-S-B	TEE, STRAIGHT THREAD RUN	1
43	N-2789-01-S-B	CONNECTOR, MALE STR THD BEADED HOSE	1

### Parts List

When ordering replacement parts/kits, please specify model, serial number and color of your unit.

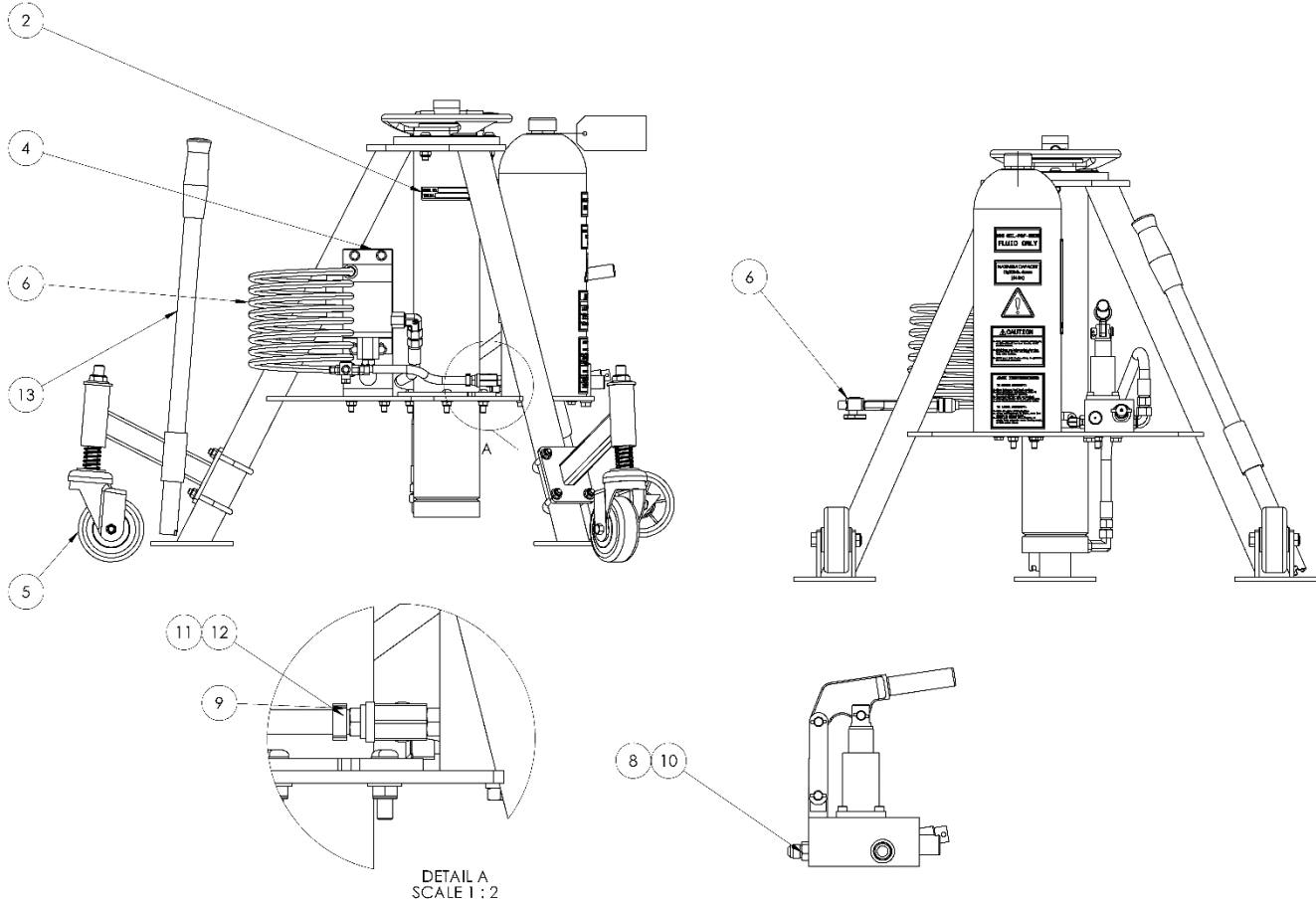

Item	Part Number	Description	Z-10951-Z1	Z-10951-A1	Z-10951-C1
1	Z-10951-81	BASE ASSEMBLY, JACK 5 TON "CE"	1	1	1
2	V-2839	LABEL, JACK TYPE/SERIAL	1	1	1
4	Z-9225	ASSEMBLY, AIR PUMP	1	1	1
5	Z-5922	ASSEMBLY, CASTER	-	-	1
6	Z-4973	ASSEMBLY, BLOWGUN	-	-	1
7	V-1778	LABEL, PRESSURE	-	-	1
8	N-2007-08-S-B	ADAPTER, -06 JIC M X -06 ORB M	-	-	1
9	H-1516-08	CLAMP, 2-EAR HOSE	-	-	1
10	N-2053-03-S-B	PLUG, HEX HD W/O-RING	-	-	1
11	N-2066-06-S-B	PLUG, HOLLOW HEX W/ O-RING	1	1	-
12	N-2789-01-S-B	CONNECTOR, MALE STR THD BEADED HOSE	1	1	-
13	H-1009-01	ASSEMBLY, HANDLE	-	-	1

### Parts List

When ordering replacement parts/kits, please specify model, serial number and color of your unit.

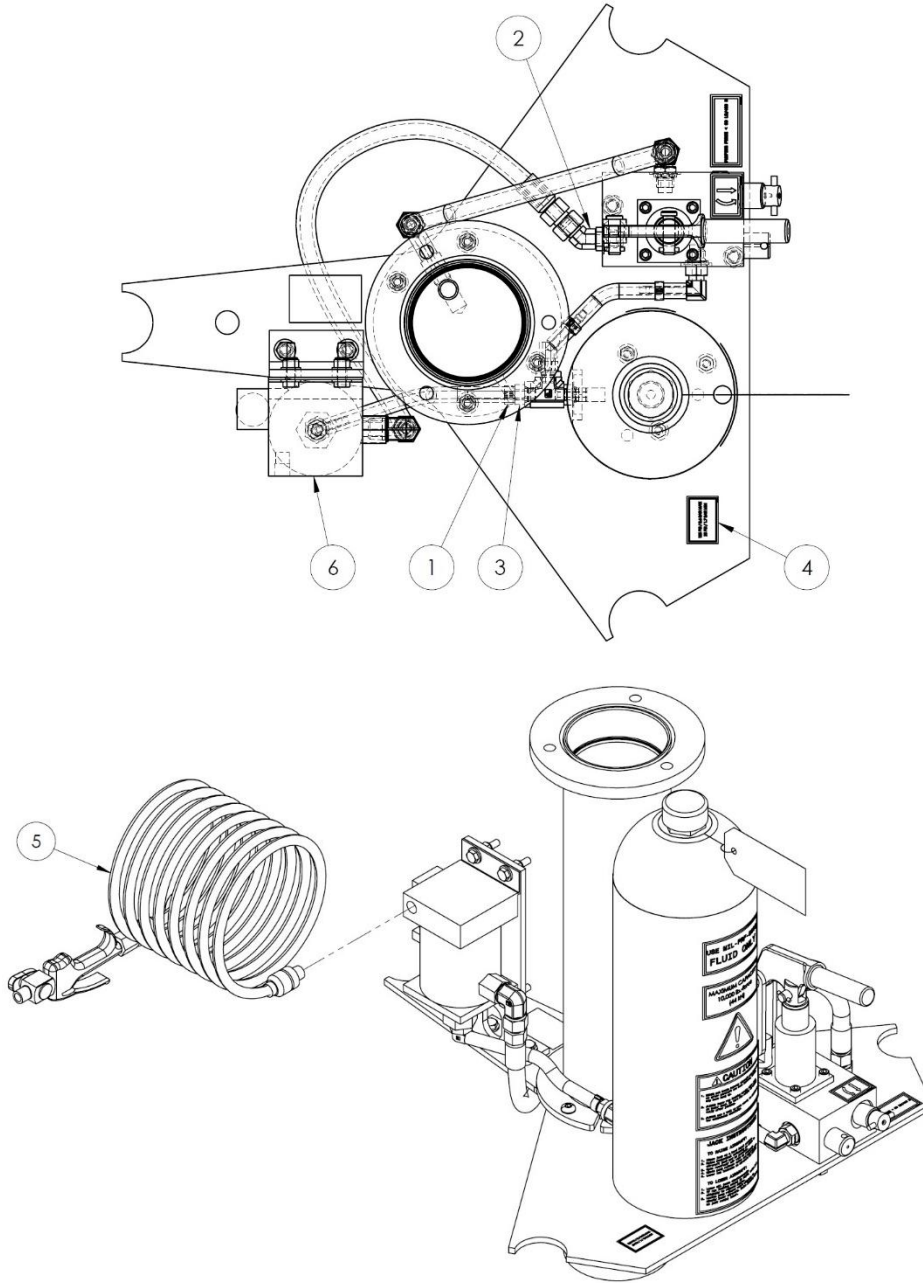

Item	Part Number	Description	Qty
	<b>K-1043-31</b>	<b>KIT, AIR PUMP; consist of:</b>	
1	H-1516-08	CLAMP, 2-EAR HOSE	1
2	N-2042-05-S-B	ELBOW, 45 DEG STR THD	1
3	N-2789-01-S-B	CONNECTOR, MALE STR THD BEADED HOSE	1
4	V-1778	LABEL, PRESSURE	1
5	Z-4973	ASSEMBLY, BLOWGUN	1
6	Z-9225	ASSEMBLY, AIR PUMP	1

**Parts List – 02-0527C0140**

When ordering replacement parts/kits, please specify model, serial number and color of your unit.

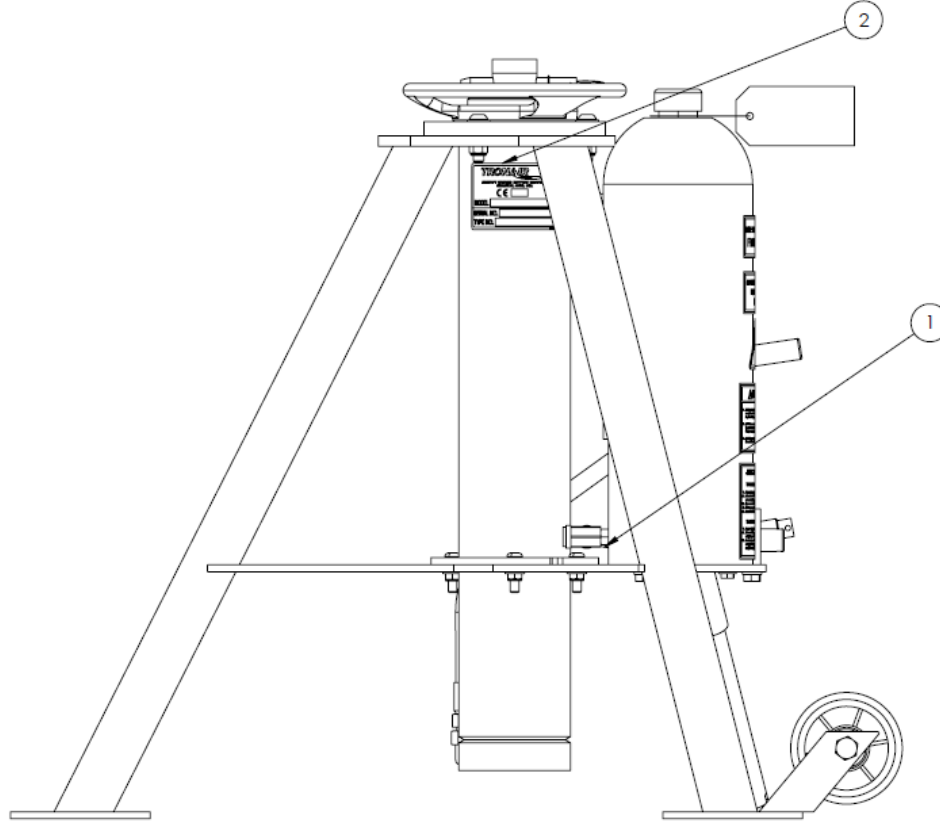

Item	Part Number	Description	Qty
1	Z-10951-Z1	ASSEMBLY, 5 TON TRIPOD (CE)	1
2	V-2840	LABEL, JACK MODEL	1

**Parts List – 02A0527C0140**

When ordering replacement parts/kits, please specify model, serial number and color of your unit.

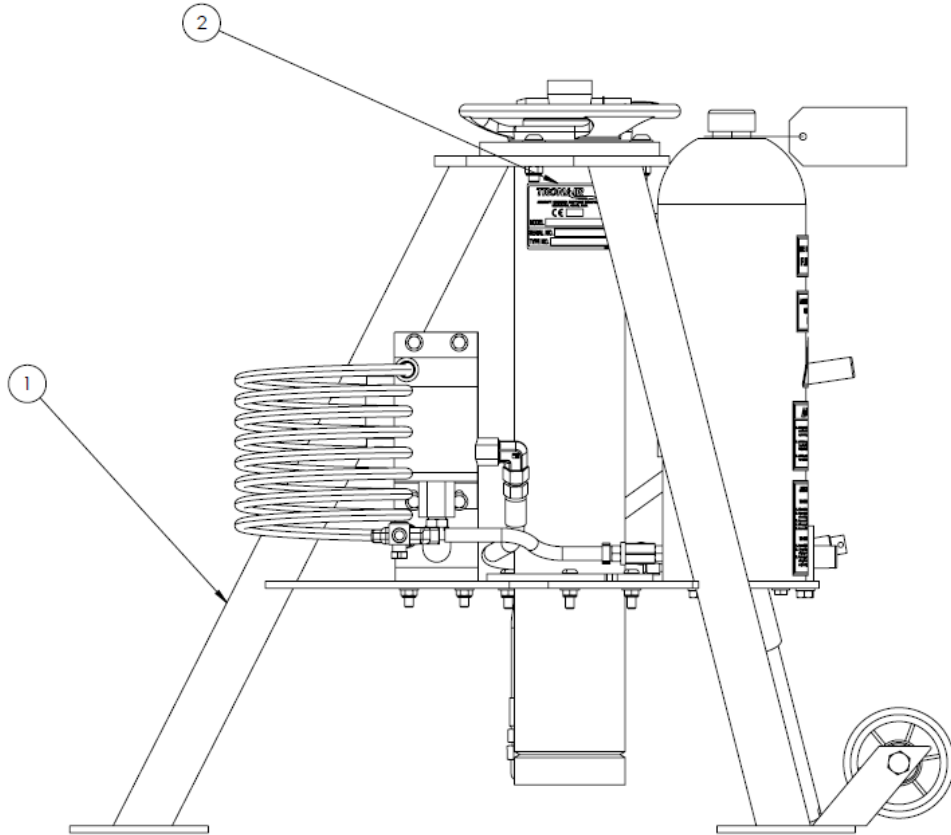

Item	Part Number	Description	Qty
1	Z-10951-A1	ASSEMBLY, 5 TON TRIPOD (CE)	1
2	V-2840	LABEL, JACK MODEL	1

**Parts List – 02C0527C0140**

When ordering replacement parts/kits, please specify model, serial number and color of your unit.

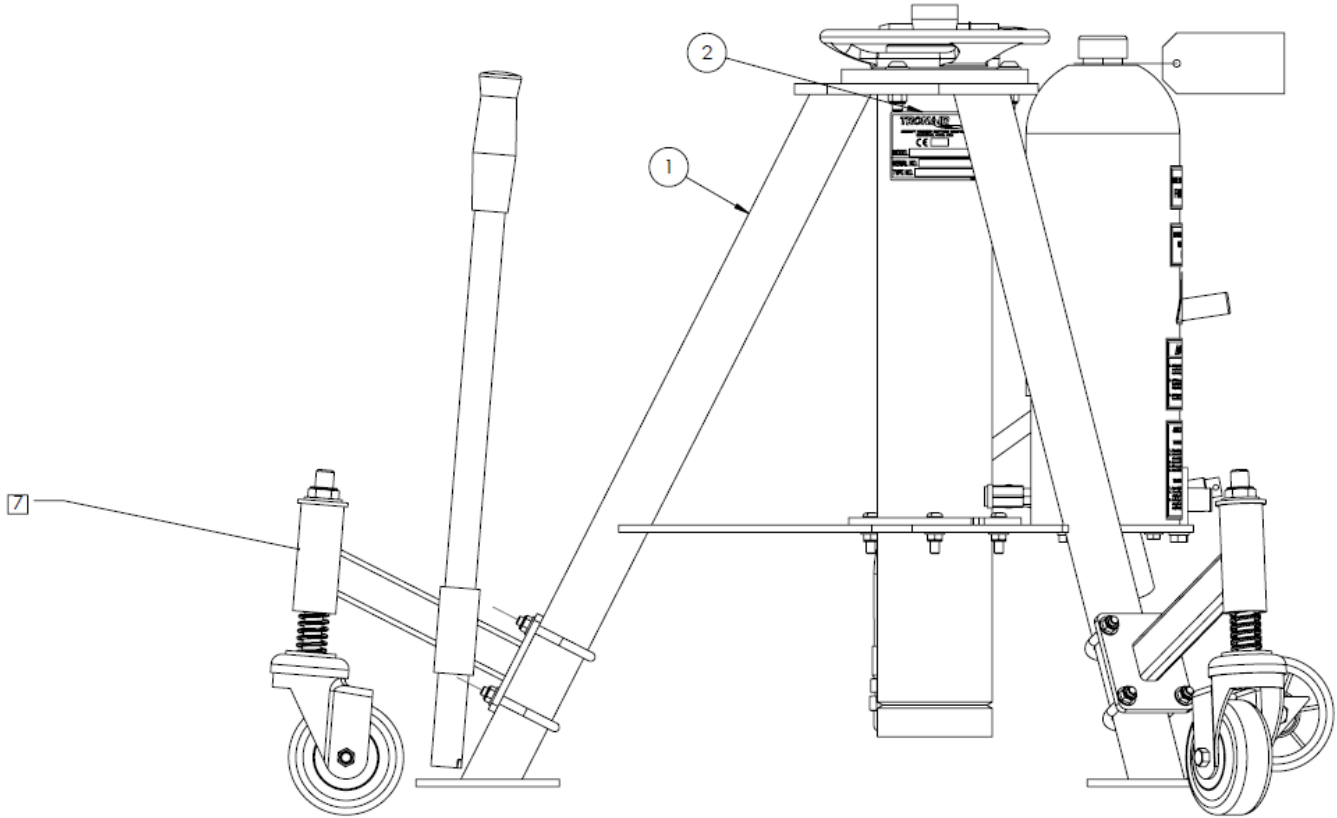

Item	Part Number	Description	Qty
1	Z-10951-C1	ASSEMBLY, 5 TON TRIPOD (CE)	1
2	V-2840	LABEL, JACK MODEL	1

**Parts List – 02-7827C0110**

When ordering replacement parts/kits, please specify model, serial number and color of your unit.

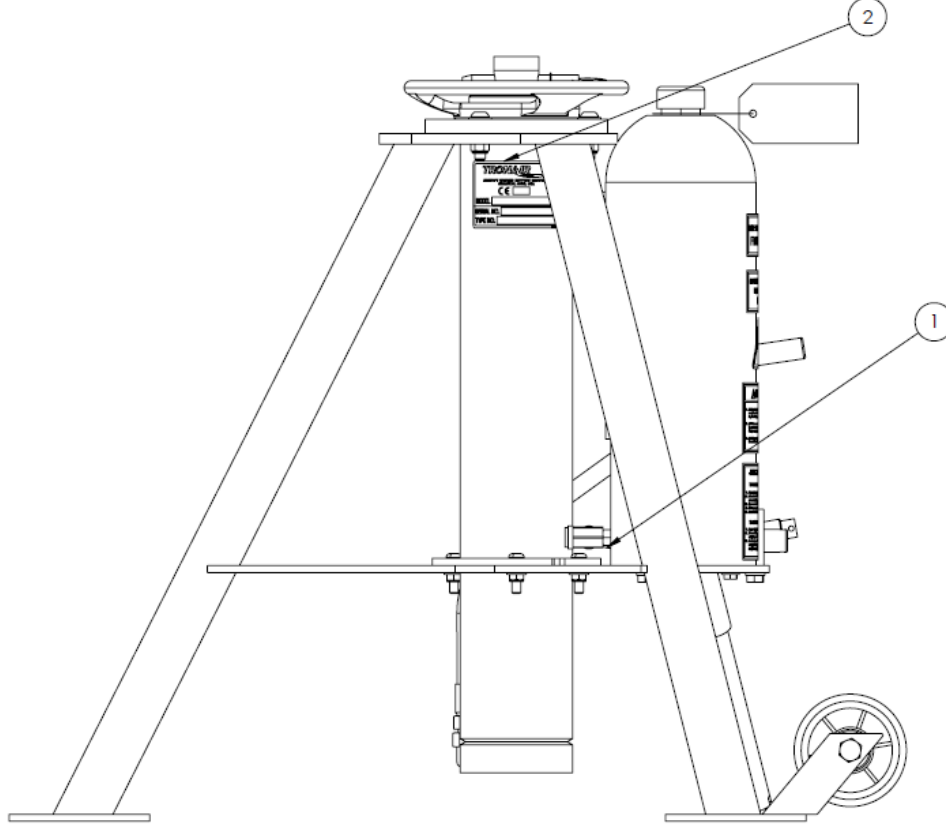

Item	Part Number	Description	Qty
1	Z-10951-Z1	ASSEMBLY, 5 TON TRIPOD (CE)	1
2	V-2840	LABEL, JACK MODEL	1

**Parts List – 02A7827C0110**

When ordering replacement parts/kits, please specify model, serial number and color of your unit.

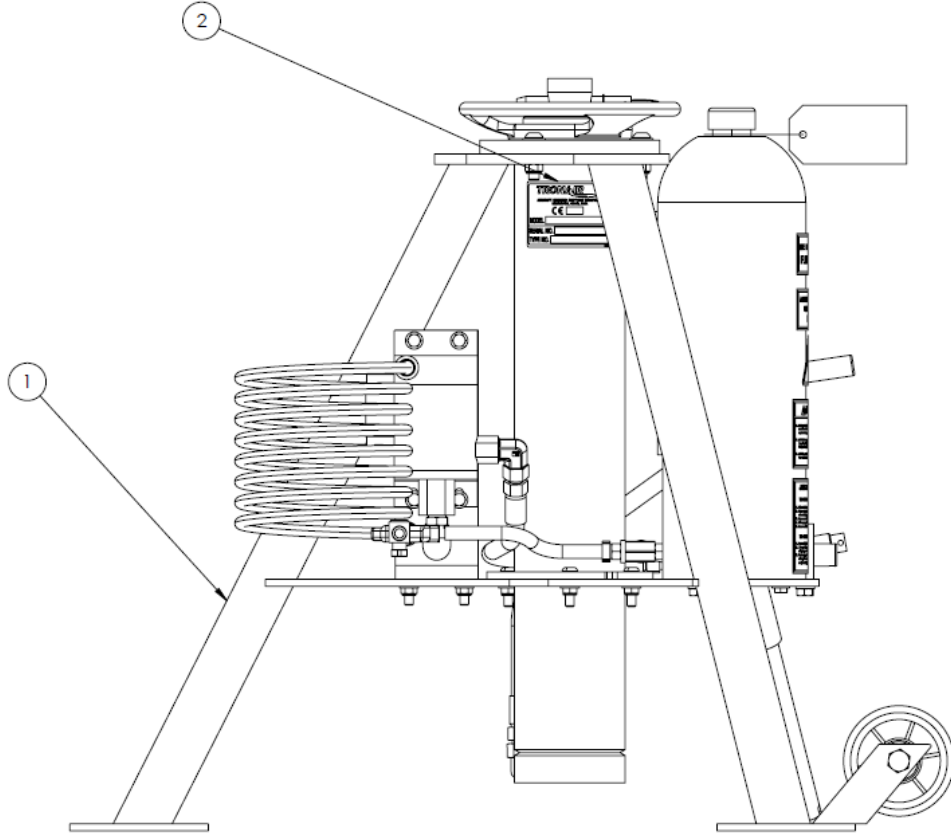

Item	Part Number	Description	Qty
1	Z-10951-A1	ASSEMBLY, 5 TON TRIPOD (CE)	1
2	V-2840	LABEL, JACK MODEL	1



## **APPENDIX I**

### **Hydraulic Schematic**



## Hydraulic Schematic

02-0527C0140, 02C0527C0140, 02-7827C0110

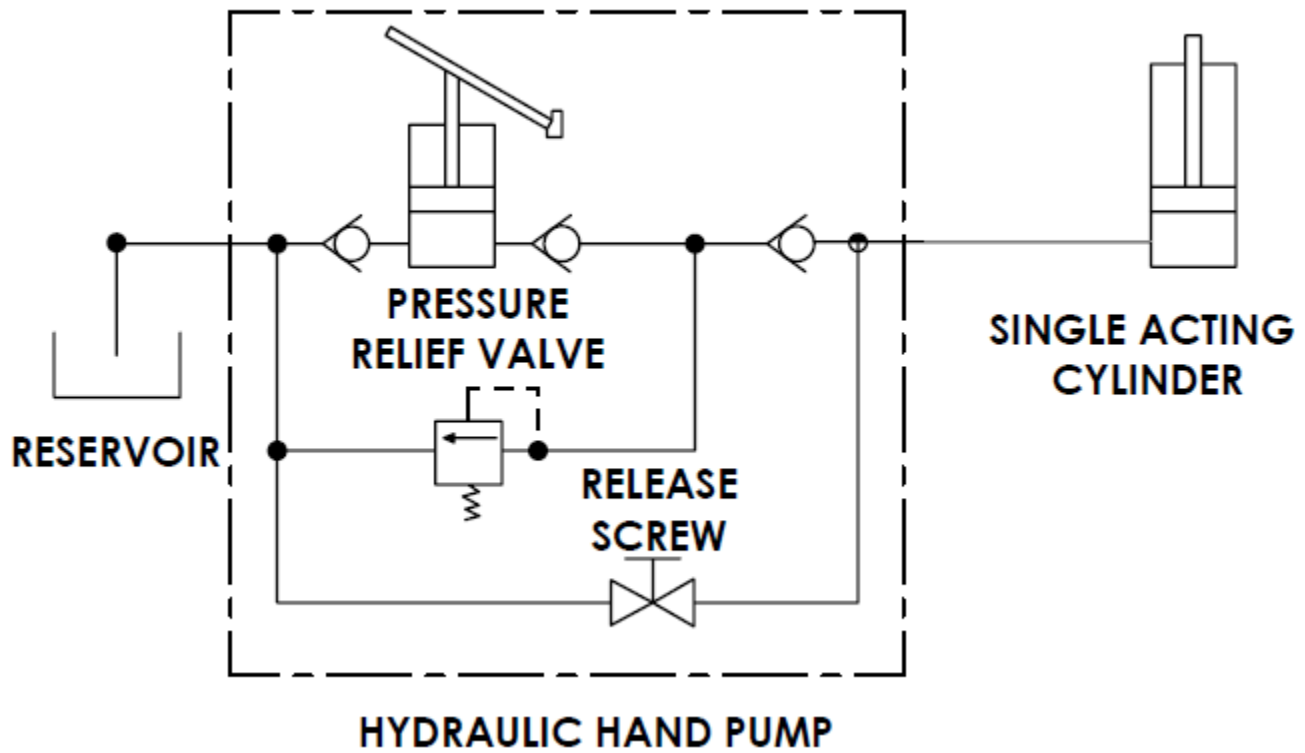

# Hydraulic Schematic

## 02A0527C0140, 02A7827C0110

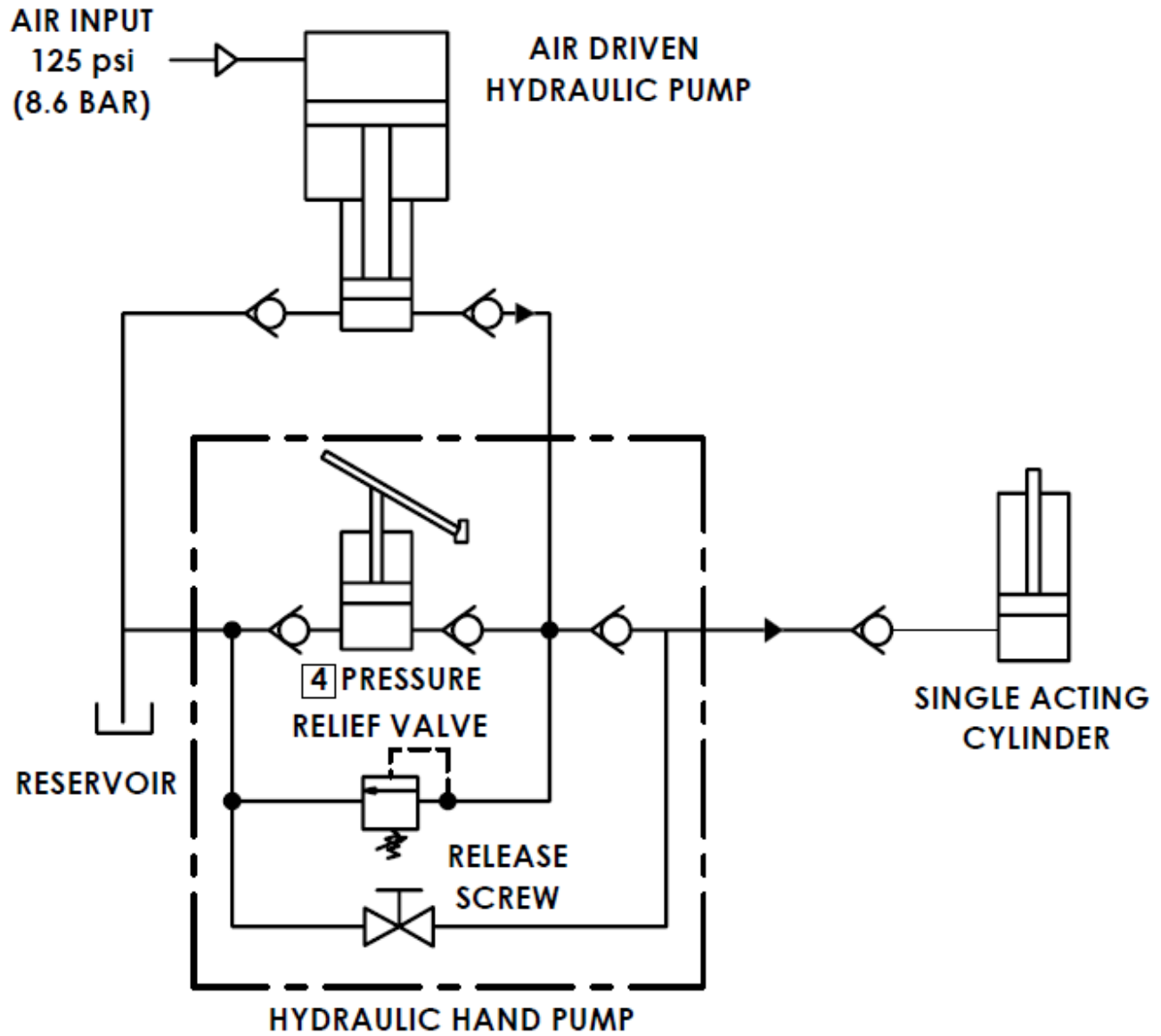



## APPENDIX II

### Haskel Air Pump Manufacturer Data





PNEUMATIC DRIVEN LIQUID PUMPS

PERFORMANCE • QUALITY • RELIABILITY





## Welcome to Haskel

Haskel is an international organization offering a worldwide service through the Haskel group of companies and factory trained distributors. The Haskel group is headquartered in Burbank, California, with facilities throughout the world. We have built an enviable reputation for quality based on high pressure fluid and gas handling equipment.

In addition to offering a comprehensive range of pneumatic driven liquid pumps, air amplifiers, pneumatic and hydraulic driven gas boosters, high pressure valves, fittings and accessories, we custom design and build power pacs and test rigs. Our continued investment in technology ensures that Haskel will stay at the leading edge of high pressure technology.

This brochure introduces our pneumatic driven liquid pump range. Technical details and advice on any of the products shown is available on request.

We are here to solve your problems. Just give us a call at 818-843-4000 or visit our website at [www.haskel.com](http://www.haskel.com) for more information or to locate a distributor.

## Why Use Haskel Pneumatic Driven Pumps?

*Our pumps offer many advantages over electrically driven pumps:*

- Safe pneumatic operation – no heat, flame or spark risk
- Up to 100000 psi (7000 bar) capability
- Infinitely variable cycling speed
- Stall feature at pre-determined pressure to hold that pressure without consuming power
- Problem-free stop/start applications
- Easily automated – many modification and control options
- Suitable for most liquids and liquefied gases
- Alternative gas drive options – sour gas, natural gas, boil off gases, nitrogen
- No need for air line lubrication – saves costs and prevents contamination
- Robust, reliable, compact and easy to maintain proven design
- Unbalanced cycling spool provides immediate response to pressure changes
- Also available in standard, or custom built power pac configurations
- Excellent worldwide service for spares and repairs
- Can be manufactured to meet API 675, ATEX, CE and NACE

## Applications include:

- Pressure testing
- Work holding/power clamping
- Jacking/lifting
- Valve actuator control
- Hydraulic cylinder actuation
- Press safety overload devices
- Roller tensioning
- Metering
- Precision lubrication and spraying
- Liquefied gas transfer



## Pressure and Flow on Demand

This guide will help you to pre-select the pump ideally suited for your application. If you have specific questions, however, we urge you to provide us with details of the duties you require from the pump, available air/gas drive pressure, and pressure/flow requirements, and we will recommend a model and any corresponding accessories.

## Output Horsepower Ratings

The pumps are categorized on their horsepower ratings (see pages 6-7). These are approximate and peak at 100 psi (7 bar), assuming adequate drive air, pressure and volume. Peak horsepower is at about 75% nominal ratio x air drive pressure, i.e. 100:1 pump @ 100 psi air drive peaks at  $100 \times 100 = 10000 \times 0.75$  psi = 7500 psi (517 bar) hydraulic pressure.

## Operation

The pumps automatically reciprocate on a differential piston principle. A large piston driven by relatively low pressure drive acts directly upon a smaller hydraulic piston.

The nominal ratio between piston sizes is indicated in the model coding and approximates to the maximum working pressure. The actual ratio is about 15% above nominal so that the pump continues to cycle when drive pressure equals nominal ratio. Initially, the pump will cycle at maximum speed acting as a transfer pump to pressurize downstream.

It will cycle at a slower rate as the fluid meets resistance until it stalls at maximum output pressure. When a pressure drop downstream occurs, it will recycle as necessary in an effort to maintain maximum pressure. Stall pressure is achieved when the outlet pressure rises and offers more resistance to the reciprocating differential piston assembly. The piston assembly then stalls when the forces balance, e.g. when drive pressure x drive piston area equals outlet (stall) pressure x driven hydraulic plunger area. The pump design is sensitive to very small pressure drops due to the low frictional resistance of the large diameter drive piston and hydraulic piston seals.

## Double and Triple Air Head Pumps

Performance can be extended by stacking air pistons without changing the hydraulic piston. Haskel multi-head pumps consume less air than competitive single head pumps of the same area, as only one head is pressurized on the return stroke; e.g., on a 1.5 hp pump additional heads can raise performance to 2 hp.

Double air head pumps are identified by the last digit 2 in the pump model number. Thus, a nominal 50:1 ratio pump with two air heads is described as a 52. Similarly, a triple air head pump is identified with a last digit 3. Thus, a 900 ratio pump with three air heads is described as a 903.

### Single Drive Head Pump

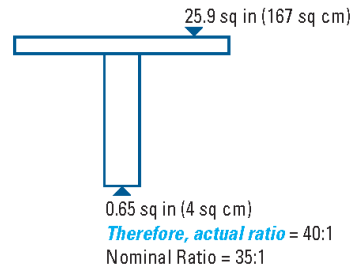

### Double Air Head Pump

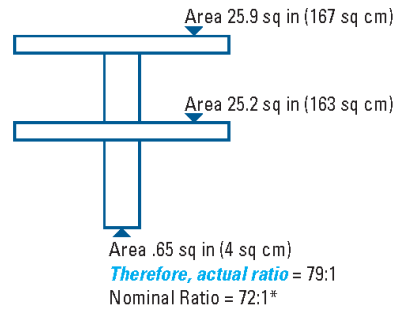

### Triple Air Head Pump

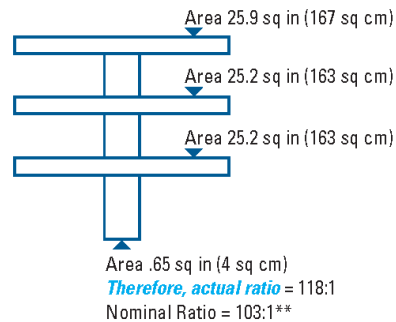

#### Nominal Ratio

\* (2) Indicates Double Drive Piston

\*\* (3) Indicates Triple Drive Piston

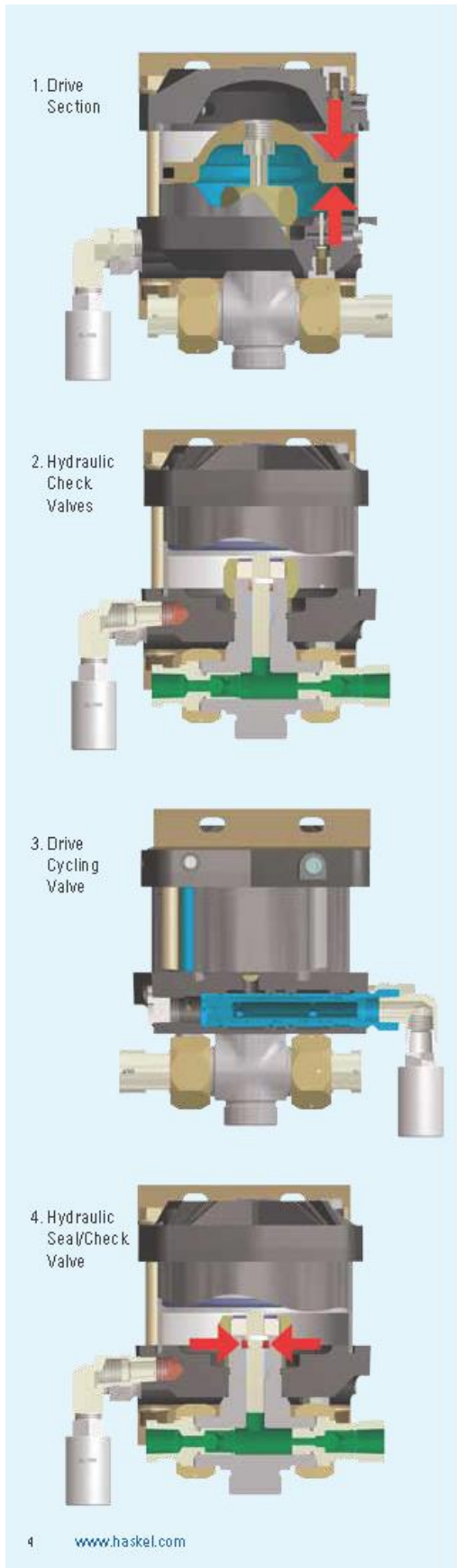

## Anatomy of a Pneumatic Driven Pump

### 1. Drive Section

The piston, complete with "O" ring seal, operates in an epoxy filled, fiberglass wound barrel, the diameter of which is constant throughout a given series of pumps. Drive media forces the piston down on the compression stroke and raises it on the suction stroke (M series have a spring return). The piston is pre-lubricated during assembly and therefore no air line lubricator is necessary.

### 2. Hydraulic Section/Check Valves

This is directly linked to the drive piston by the hydraulic piston, the bottom portion of which is in the hydraulic body. Outlet flow and pressure are determined by the area of the hydraulic piston head, its nominal ratio with the drive piston head, and drive pressure. On the down stroke, liquid in the hydraulic section is forced under compression through the outlet check valve. Fresh liquid is induced via the inlet check valve on the return stroke. These check valves control the flow of liquid through the hydraulic section. They are spring-loaded and have a very low cracking pressure, allowing maximum opening on the induction stroke. The pressure of hydraulic fluid on the down stroke closes the inlet check valve and acts against the spring to open the outlet check valve.

### 3. Drive Cycling Valve

This is a pilot-operated, unbalanced, lightweight spool, which directs drive pressure, first to the top of the drive piston, and then to the underside to reciprocate the piston (cycle). It actuates via pilot valves at the top and the bottom of the stroke, which causes the unbalanced spool to shift and reciprocate the piston.

### 4. Hydraulic Seal/Check Valves

This is one of the few wear parts. Its function is to allow the hydraulic piston to reciprocate without passing fluid into the drive section. The liquid, its pressure and its temperature determine seal specification. A distance piece can be incorporated between drive and hydraulic sections for complete contamination-free operation on most Haskel pumps.



## Pump Selection Information

All Haskel pumps are identified by letters coding the type of pump, followed by a number indicating the practical working ratio

of the drive area to the hydraulic plunger area. These letters are explained in the chart below.

### Pump Model Letter Coding

<b>M</b>	.875" stroke .33 hp miniature pump series	<b>XH</b>	2" stroke 1.5 + 2 hp Extreme High Pressure pump series
<b>S</b>	Stainless steel hydraulic piston and body	<b>G</b>	4.5" stroke 6 hp pump series
<b>29723</b>	.33 hp Chemical Pump	<b>8</b>	4.5" stroke 8 hp pump or booster series
<b>D (Prefix)</b>	Pump incorporates a Distance Piece	<b>14</b>	4" stroke 10 hp pump series
<b>D (Suffix)</b>	Double Acting pump	<b>W</b>	Polyurethane U-cup dynamic seal
<b>4B</b>	1" stroke .75 hp pump series (bottom inlet only)	<b>F</b>	UHMWPE (Ultra-high Molecular Weight Polyethylene Dynamic Seal
<b>A</b>	2" stroke 1.5 + 2 hp pump series	<b>T</b>	Reinforced teflon dynamic seal
<b>H</b>	2" stroke 1.5 + 2 hp High Pressure pump series	<b>V</b>	Viton o-ring static seal
<b>-C</b>	Filter, regulator with gauge and shut-off/speed control valve	<b>-B</b>	Bottom inlet
		<b>-CP</b>	Chemical Pump

## Quick Model Comparison Chart

The chart to the right shows the pressure/flow capability of each pump in the range. The diagonal lines show constant output horsepower for each series. The model ratios are circled.

### Example

The pressure required is 2175 psi (150 bar). The flow required is 215 cubic inches (3.52 liters) per minute. The black dot plots position. Only models on diagonals to the right of the dot will meet the demand; e.g., the -35 ratio 1.5 hp pump, assuming a supply at 100 psi (7 bar) and 70 scfm (119m<sup>3</sup>/hr) can be met; if not, a -32 or -52 2 hp pump would be needed.

**Note:** For specific performance curves, refer to *Liquid Pump Rapid Reference Guide*.

The diagonal horsepower lines in the chart below are based on 100 psi (7 bar) drive pressure. Drive flow requirement is different for each series as follows:

<b>.33 hp</b>	15 scfm (25 m <sup>3</sup> /hr)
<b>.75 hp</b>	45 scfm (76 m <sup>3</sup> /hr)
<b>1.5 hp</b>	70 scfm (119 m <sup>3</sup> /hr)
<b>2 hp</b>	85 scfm (144 m <sup>3</sup> /hr)

<b>3 hp</b>	85 scfm (144 m <sup>3</sup> /hr)
<b>6 hp</b>	175 scfm (297 m <sup>3</sup> /hr)
<b>8 hp</b>	225 scfm (382 m <sup>3</sup> /hr)
<b>10 hp</b>	270 scfm (459 m <sup>3</sup> /hr)

Reduced air drive flow or pressure will result in a corresponding reduction in output horsepower. This chart can be used to select pump series and model ratio.

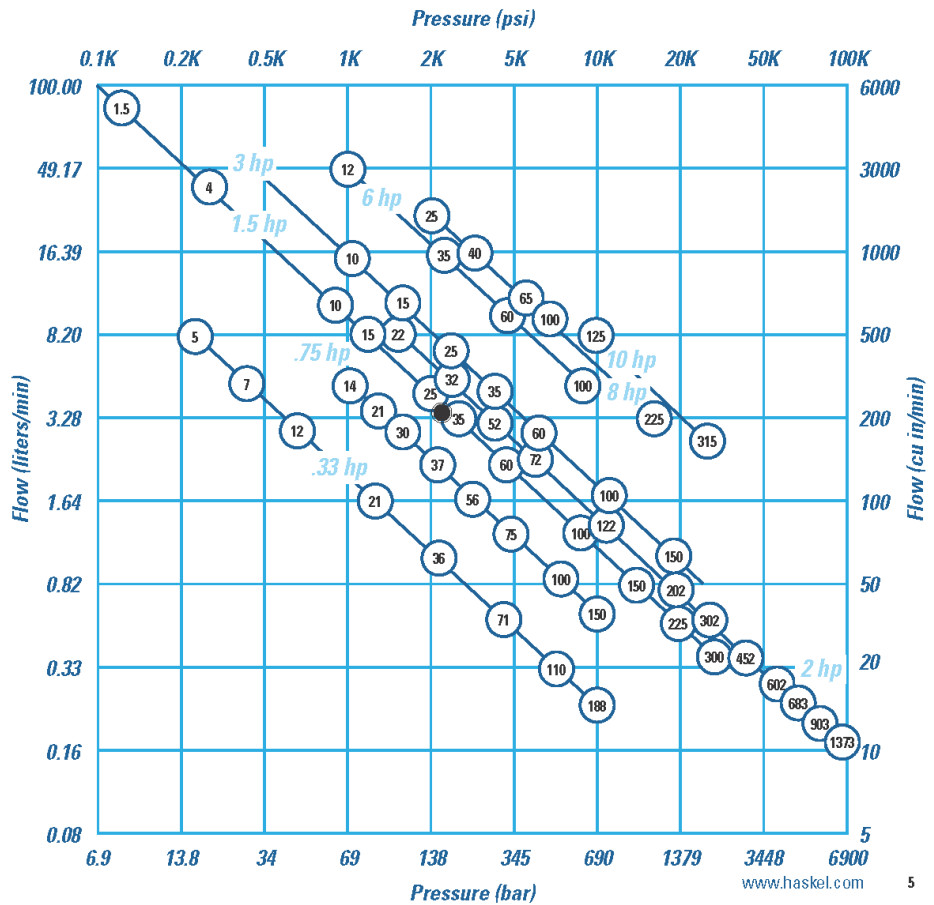

## Performance and Specification Overview

Max Drive Drive Head HP	Pump Model Code	Nominal Ratio	Actual Ratio	Mainimum Rated Output Pressure				Displacement/Cycle		Maximum Flow		
				Continuous		Intermittent		cu in	ml	cu in/min	l/min	
				psi	bar	psi	bar					
125 psi/8.6 bar Single 0.33 hp	M, MDSTV	-5	5.6	625	43	625	43	0.83	13.6	506	8.30	
	M, MS	-7	7.8	900	62	900	62	0.60	9.8	366	6.00	
		-12	14	1500	103	1500	103	0.36	5.9	234	3.83	
	M, MS, 29723	-21	25	2600	179	2600	179	0.20	3.3	130	2.13	
		-36	41	4500	310	4500	310	0.12	2.0	78	1.28	
		-71	82	8800	607	8800	607	0.060	1.0	39	0.64	
		-110	126	13500	931	13500	931	0.039	0.6	25	0.42	
	M, MS	-188	217	15000	1034	15000	1034	0.023	0.4	18	0.29	
	MS	-220	237	20000	1380	25000	1723	0.021	0.344	14	0.22	
	100 psi/7 bar Single 0.75 hp		-14	16	1500	103	1500	103	0.90	14.7	428	7.01
		-21	24	2300	159	2300	159	0.60	9.8	285	4.67	
		-25	29	2700	186	2700	186	0.50	8.2	238	3.89	
4B		-30	34	3200	221	3200	221	0.43	7.0	204	3.35	
		-37	42	3800	262	3800	262	0.35	5.7	166	2.72	
		-55	63	6000	414	6000	414	0.22	3.6	105	1.71	
		-75	86	7800	538	7800	538	0.17	2.8	81	1.32	
		-100	114	10600	731	10600	731	0.13	2.0	62	1.01	
		-150	171	15000	1034	15000	1034	0.088	1.44	42	0.68	
150 psi/10.5 bar Single 1.5 hp		DSTV	-1.5	1.6	120	8	160	11	31.90	513	5104	83.6
	ATV, DTV	-4	80	690	48	1200	83	20.00	328	3200	52.4	
		-B10	11.5	1600	110	1600	110	4.05	66.4	1215	19.9	
		-B15	17	2400	165	2400	165	2.70	44.3	810	13.3	
	AW, ASF, DF, DSF, DSTV	-25	29	4000	276	4000	276	1.62	26.6	486	8.0	
		-35	40	5700	393	5700	393	1.16	19.0	348	5.7	
		-60	69	9800	676	9800	676	0.67	11.0	201	3.3	
		-100	115	15000	1034	16500	1138	0.41	6.7	123	2.0	
		-150	173	15000	1034	20000	1380	0.27	4.5	81	1.3	
		-151	173	25000	1724	25000	1724	0.27	4.5	81	1.3	
150 psi/10.5 bar Double 2 hp	HF, HSF, DHF, DSHF	-225	260	30000	2069	37000	2551	0.18	3.0	41	0.7	
		-300	345	30000	2069	50000	3448	0.14	2.3	32	0.5	
	HF	-450	533	25000	1724	45000	3403	0.091	1.5	20	0.3	
		-B22	23	3200	221	3200	221	4.05	66.4	1215	19.9	
	AW, ASF, DF, DSF, DSTV	-B32	34	4800	331	4800	331	2.70	44.3	810	13.3	
		-52	57	5000	345	8000	552	1.62	26.6	486	8.0	
		-72	80	11000	758	11000	758	1.16	19.0	348	5.7	
		-122	138	15000	1034	19000	1310	0.67	11.0	201	3.3	
	HF, HSF, DHF, DSHF	-202	230	30000	2069	33000	2275	0.41	6.7	92	1.5	
		-302	346	30000	2069	50000	3448	0.27	4.5	61	1.0	
100 psi/7 bar Triple 2 hp	DXHF, DSXHF	-452	520	30000	2069	70000	4827	0.18	3.0	41	0.7	
		-602	690	30000	2069	75000	5171	0.14	2.3	32	0.5	
		-683	780	30000	2069	70000	4827	0.18	3.0	25	0.41	
	DSXHW	-903	1038	30000	2069	75000	5171	0.14	2.3	20	0.33	
		-1373	1575	30000	2069	100000	6895	0.086	1.4	12	0.197	
	AFD, DFD, ASFD, DSFD	-B60	69	6500	448	6500	448	1.34	2.2	369	6.0	
	150 psi/10.5 bar Single 3 hp		-10	11.5	1600	110	1600	110	8.10	133	1823	29.9
			-15	17	2400	165	2400	165	5.40	89	1215	19.9
		ASFD	-25	29	4000	276	4000	276	3.24	53.2	729	11.9
		-35	40	5700	393	5700	393	2.32	38.0	522	8.6	
		-60	69	9800	676	9800	676	1.34	22.0	302	4.9	
		-100	115	15000	1034	16500	1138	0.82	13.4	185	3.0	
		-150	173	15000	1034	20000	1380	0.54	9.0	122	2.0	
		-202	230	30000	2069	33000	2275	0.82	13.4	144	2.4	
125 psi/8.6 bar Single 6 hp		GWD, GSF, DGFD, DGSFD, DGSTVD	-12	14.8	1850	128	4000	276	15.9	260	5009	82.1
			-35	40.3	4375	302	4375	302	6.0	98	1890	31.0
	GW, DGF, GSF, DGSF, DGSTV	-60	69	7500	517	7500	517	3.5	57	1103	18.1	
		-100	115	8000	552	10000	690	2.1	34	662	10.8	
	125 psi/8.6 bar 8 hp	8SFD, 8DSFD, 8DSTVD	-25	27.5	3575	246	4000	276	14.0	229	2660	44
			-40	43.5	6000	414	6000	414	8.90	145	1691	28
		8SFD	-65	73	10000	690	10000	680	5.40	88	1026	17
		8DSFD	-100	112	10000	690	10000	680	3.52	57.5	669	11
		8HSFD	-225	253	22500	1530	22500	1530	1.56	25.5	296	5
		10 hp		-125	138	16000	1103	16000	1103	8.80	144	704
D14STD, D14SFD			-315	347	36000	2482	36000	2482	3.50	57.4	280	4.6

Typical Performance Based on 100 psi (7 bar) Pressure and Drive Flow Data on Page 5							
Outlet Pressure		Outlet Flow		Outlet Pressure		Outlet Flow	
psi	bar	cu in/min	l/min	psi	bar	cu in/min	l/min
225	15.5	500	8.20	415	29	249	4.09
300	21	350	5.70	600	41	160	2.60
700	48	200	3.28	1125	78	100	1.64
1500	103	90	1.48	2000	138	48.9	0.80
1700	117	70	1.15	3100	214	39.6	0.65
3000	207	39	0.64	6000	414	19	0.31
7500	517	20	0.33	8500	586	17	0.28
9000	345	18	0.30	10000	690	14	0.23
7500	517	14	0.23	15000	1034	12	0.20
700	48	400	6.55	1450	100	61	1
1000	69	270	4.42	2000	138	120	2
1250	86	230	3.77	2500	172	61	1
1500	1034	200	3.28	3000	207	62	1
1750	121	170	2.78	3500	241	82	1.33
2000	138	110	1.8	5000	345	66	1.08
2500	172	87	1.42	7500	517	37	0.6
9000	345	57	0.93	10000	690	26	0.43
7500	517	37	0.6	15000	1034	7	0.11
50	3	5000	81.9	150	10.3	1000	16.4
100	7	1953	32	400	28	750	12.3
400	28	1000	16.4	990	68	500	8.19
750	52	598	9.8	1600	110	200	3.28
1000	69	403	6.6	2500	172	195	3.2
2000	138	350	4.1	3600	248	98	1.6
3000	207	152	2.5	6200	427	50	0.82
4000	276	100	1.64	10000	690	24.4	0.4
7000	483	59.7	0.98	15000	1034	29.9	0.49
7000	483	59.7	0.98	15000	1034	29.9	0.49
7500	517	39.6	0.65	24000	1655	9.8	0.16
15000	1034	29.9	0.49	27000	1862	20.1	0.33
36000	2483	14.6	0.24	45000	3103	9.2	0.15
400	28	799	13.1	2100	145	200	3.28
700	48	500	8.2	3000	207	152	2.5
1900	131	299	4.9	5000	345	97.6	1.6
2000	138	226	3.7	7500	517	50	0.82
4000	276	122	2	12000	828	40.2	0.66
7000	483	91.5	1.5	20000	1379	20.1	0.33
10000	690	45.2	0.74	30000	2069	15.2	0.25
10000	690	34.8	0.57	40000	2789	15.2	0.25
15000	1034	24.4	0.4	50000	3448	12.2	0.2
15000	1034	19.5	0.32	60000	4138	4.9	0.08
15000	1034	15.9	0.26	70000	4828	5.5	0.09
16000	1103	9.2	0.15	90000	6207	3.1	0.05
1000	69	348	5.7	5500	379	152	2.5
500	34	1520	24.9	1000	69	380	6.22
750	52	1030	16.88	1500	103	260	4.26
1000	69	652	10.85	2500	172	162	2.66
1500	1034	465	7.62	3500	248	100	1.64
3000	138	248	4.07	6000	414	56	0.92
5000	345	151	2.48	10000	690	41	0.67
7500	517	103	2	15000	1034	27	0.44
10000	690	63	1.03	20000	1379	47	0.77
200	14	5004	82	1200	83	1454	24
1000	69	1770	29	3500	241	600	9.8
2000	138	976	16	5500	379	397	6.5
2000	138	573	9.4	10000	690	195	3.2
1000	69	2400	39.3	2500	172	280	4.6
2000	138	1420	23.2	4000	276	200	3.27
3000	207	880	14.4	6000	414	310	5.08
8000	345	555	9.1	10000	690	163	2.67
10000	690	270	4.4	20000	1379	144	2.36
8000	552	488	8.0	12000	828	195	3.2
15000	1034	238	3.9	30000	2069	79.3	1.3



### Guidelines for Continuous Duty Applications for Maximizing Seal Life Performance

Pump Series	Maximum Cycles per Minute
0.3 hp	325 cpm
0.75 hp	225 cpm
1.5, 2.0 and 2.2 hp (Single and Double Drive Piston)	80 cpm
2.0 hp (Triple Drive Piston)	60 cpm
3.0 hp	80 cpm
6.0 hp	60 cpm
8.0 hp	50 cpm
10.0 hp	40 cpm

## .33 hp (.25 kW) M Series Pump Models



### Key Features

- Choice of 5 models, 9 ratios, 27 possible combinations
- Flows to 2 gpm (7.5 l/min)
- Choice of wetted materials
- Single air head
- Drive pressure 25 to 125 psi (1.8 to 9 bar)
- Pressures to 25000 psi (1724 bar)
- All Hydraulic fluids, water (plain or DI), solvents, mild chemicals, liquefied gases

### Optional Modifications

Number	Description
-HP	Hand pump attachment (with handle). Provides manual operation of pump for precision pressure control or use without air power.
26082	Handle only.
26220-2	With handle.
26220-3	Without handle.
	Kits for converting existing units.
-V	Manual release with relief valve. For M and MS pumps only. Provides high pressure needle valve with internal adjustable safety relief downstream of pump outlet checks. Tank return is 1/2" NPT in pump body.
26063-3	Dead Man valve. 1/4" NPT port.
26064-3	Combination air regulator/filter with gauge. 1/4" NPT port.
26065-3	Speed control valve. 1/4" NPT port.
26065-3 plus 26064-3	-C air controls installed on pump. 1/4" NPT port.
28320	Manifold mount inlet port. Provides O-ring boss in aluminum block to enable mounting on side of tank below oil level. Modification applies to M-21 through M-188 only.
28890	Palm or foot start/stop button drive. Spring loaded shut.
28700-1	Air OP release valve.
28826	Remote start/stop control. Provides 1/2" NPT bleed signal port for single line remote control.
29002	Viton air drive.
29697	Single stroke from remote air pulse. Useful for metering applications. One stroke per air pulse signal; eliminates automatic cycling. 1/2" NPT signal port.
51331	EPR seals for liquid section for 29723-10X ratio pumps.
51788	Piped exhaust—standard. Provides connection ports for drive and pilot exhausts. Enables under tank top mounting and/or natural gas drive.
51794	Piped exhaust—sour gas. With hand pump (HP).
51794-2	Piped exhaust—sour gas. Without hand pump (HP).
51804	Muffler (for use with piped exhaust modifications below). 1/2" NPT male port.

Model	Nominal Ratio	Maximum Working Pressure	Displacement per Cycle
M, MDSTV	-5	625 psi (43 bar)	.83 cu in (13.6 ml)
M, MS <sup>21</sup>	-7	900 psi (62 bar)	.6 cu in (9.8 ml)
	-12	1500 psi (103 bar)	.36 cu in (5.9 ml)
M, MS <sup>21</sup> , 29723 <sup>1*</sup>	-21	2600 psi (179 bar)	.2 cu in (3.3 ml)
	-36	4500 psi (310 bar)	.12 cu in (2.0 ml)
	-71	8800 psi (607 bar)	.06 cu in (1.0 ml)
	-110	13900 psi (931 bar)	.039 cu in (0.6 ml)
	-188	15000 psi (1034 bar)	.023 cu in (.4 ml)
MS	-220	25000 psi (1723 bar)	.021 cu in (.34 ml)

\* Not available in 188:1 ratio

(3) Maximum intermittent pressure for stainless steel in the MS and 29723 is 10000 psig (690 bar)

For service codes, see page 17.

For weights and dimensions, see page 18.

Number	Description
51809	Normally open air operated release with relief valve. Provides highest release flow capacity. Will hold full pump psi piloted from drive air. Vents are not threaded. Ref. drawing 56643 for tank top mounting parts.
51809-1	Normally closed air operated release with relief valve. Used to hold hydraulic jacks. Will release up to 11000 psi (using 100 psi air). Vents are not threaded. Ref. drawing 56643 for tank top mounting parts. Not available in 188:1 ratio.
51810	Safety relief valve. Relief is upstream of outlet check. Vent hole 1/16" NPT M or MS series -21 through 188.
51811	External air pilot. Provides 1/2" NPT port for external air to pilot for remote start/stop.
52340	Solid air cap.
52950	Electric stroke counter provision. Micro switch (BZE5-2RQ) mounted on upper cap trips with each cycle.
53175	Level II cleaning.
53304	High pressure outlet port. Fits 1/4" O.D. high pressure threaded and coned tube.
53784	Piped exhaust (drive only). For field conversion of any .33 HP pump. Provides 1/2" NPT exhaust port.
53935	Low temperature drive. Enables operation down to 5°F. Some sacrifice of seal life at normal temperature. M or MS series.
54179	Stroke adjuster (includes 29697 above). Useful for metering applications. Knurled knob with vertical scale on pump cap.
57905	No return spring. Provides improved fill on suction stroke pumping liquefied gases by utilizing the inlet pressure. Only available on M and MS series.
59888	Cycle timer installed.
80103	Noise reduction kit fitted.
80348	SAE outlet for M-pumps, 1/2" SAE, 6500 psi (448 bar) max.
81499	EPR Seals for M and MS series for Liquid Section.
82367	SS trim for 1/2 hp drive
82800	ATEX Modification (Available on MS & 29723 but not M series).
85630	Conversion kit, new style exhaust muffler.
86337	Extended life air drive.

## .75 hp (.56 kW) Pump Models



### Key Features

- One model available in 9 ratios
- Output pressures to 15000 psi (1034 bar)
- Flows to 1.5 gpm (5.7 l/min)
- Choice of wetted materials
- Single air head
- Drive pressure 3 psi to 100 psi (.2 to 7 bar)

Model	Nominal Ratio	Maximum Working Pressure	Displacement per Cycle
4B	-14	1500 psi (103 bar)	9 cu in (14.8 ml)
	-21	2300 psi (159 bar)	6 cu in (9.8 ml)
	-25	2700 psi (186 bar)	5 cu in (8.2 ml)
	-30	3200 psi (221 bar)	4.3 cu in (7.1 ml)
	-37	3800 psi (262 bar)	3.5 cu in (5.7 ml)
	-55	6000 psi (414 bar)	2.2 cu in (3.6 ml)
	-75	7800 psi (538 bar)	1.7 cu in (2.8 ml)
	-100	10600 psi (731 bar)	1.3 cu in (2.1 ml)
	-150	15000 psi (1034 bar)	0.88 cu in (1.4 ml)

For service codes, see page 17.

For weights and dimensions, see page 19.

### Optional Modifications

Number	Description	Number	Description
-C	Air drive controls.	59888	Cycle timer installed.
56364	Extreme cycling service. Not recommended for long stall periods.	80637	SAE outlet fitting for ratio 37 to 100, N° SAE 6000 psi (448 bar) max.
56394	External air pilot port, N° NPT. Allows remote start/stop of pump.	82104	Viton air drive.
57639	Low drive air pressure. Allows user to regulate drive air to as low as 3 psi (.2 bar).	82900	ATEX modification.
57960	Single acting drive. Used for pumping liquefied gases under pressure.	86337	Extended life air drive.
58475	K° NPT port on drive for recycle valve connection.		
59354	Noise reduction kit fitted.		



## 1.5 hp (1.12 kW) Pump Models



### Key Features

- Choice of 11 models, 13 ratios, 48 possible combinations
- Output pressures to 50000 psi (3448 bar)
- Flows to 22 gpm (83.0 l/min)
- Choice of wetted materials
- Single air head
- Drive pressure 3 to 150 psi (.2 to 10 bar)

Model	Nominal Ratio	Maximum Working Pressure	Displacement per Cycle
DSTV <sup>PI</sup>	-1.5	160 psi (11 bar)	319 cu in (513.0 m)
ATV, DTV <sup>PI</sup>	4	1200 psi (83 bar)	200 cu in (328.0 m)
AW, ASF, DF, DSF, DSTV	-B10 -B15 -25 -35 -60	1600 psi (110 bar) 2400 psi (165 bar) 4000 psi (275 bar) 5700 psi (393 bar) 9800 psi (675 bar)	4 cu in (66.4 m) 2.7 cu in (44.3 m) 1.6 cu in (26.5 m) 1.2 cu in (19 m) .7 cu in (11 m)
AW, ASF, DF, DSF, DSTV	-100 -150	16800 psi (1138 bar) 20000 psi (1375 bar)	4 cu in (6.7 m) 28 cu in (4.5 m)
HF, HSF, DSHF	-151 -225 -300	29000 psi (1724 bar) 37000 psi (2551 bar) 50000 psi (3448 bar)	28 cu in (4.5 m) .18 cu in (3.0 m) .14 cu in (2.3 m)
HF	-450	45000 psi (3103 bar)	.09 cu in (1.5 m)

(1) These series are "lift" pumps and maximum outlet pressure is (air drive x pump ratio) + inlet pressure.

For service codes, see page 17.  
For weights and dimensions, see page 20.

### Optional Modifications

Number	Description
-C	Air controls (filter, regulator, gauge, shut-off). 1/2" NPT.
-CP	Air controls with precision regulator. 1/2" NPT.
-C0	Air controls with recycle button. 1/2" NPT.
-CPO	Air controls with precision regulator and recycle button. 1/2" NPT.
-B	Bottom Inlet (designate "B" before ratio dash number; "BR" on -B10, -B15, -B22 and -B32) 1.5 hp and 2 hp pumps (not applicable to high output, chemical, 2.2 hp, or AWD series pumps).
-W	Additional upper foot bracket.
16821	Low air pressure control feature. For operating at air pressures as low as 3 to 4 psi (.2 to .3 bar). Includes 28881 modification.
16831	Low temperature modification. For special sealing in air drive for operating temperatures from as low as -20°F up to normal +120°F.
16834	Exhaust adapter. With back pressure balance piston.
17860	Electrical stroke counter provision. Includes BZ65-2RQ microswitch.
25721	Mechanical stroke counter, installed (6 digit).
27964	Interconnecting inlet-outlet tubing. 1/2" female for 4:1 ratio series pumps (ATV-4 or DTV-4).
28000	Threaded vent (or purge) ports on standard distance piece. Except 1.5:1 ratio.
28003	Test port. Provides access port in pump's body between inlet and outlet check valves for 1.5 hp and 2 hp pumps. -10 ratio or higher, single acting.
28881	Air pilot modification. 1/2" NPT. Allows remote start/stop of pump.
29376	Three-way cycling spool. For 1.5 hp and 2 hp single acting pumps, for use with CO <sub>2</sub> .
29702	Single stroke modification.

Number	Description
29806	Double distance piece. For 1.5 hp and 2 hp pumps only, except 1.5:1 ratio.
51050	Extreme service cycling modification. Not recommended for long stall periods.
51056	Exhaust/pilot vent combination.
51331	EPR (Ethylene propylene) static seals in wetted section. Applies to distance piece pumps only.
51345	Sour gas drive provision to N.A.C.E. specifications. 1.5 hp to 2.2 hp distance piece pumps only, single air head and double air head.
52788	Viton seals air drive.
53925	Severe Arctic low temperature service. -25, -35, -60, -100, -150, -151, -225, -300, -450 ratios.
54885	Rotate pump body 90° from standard.
54935	SS trim for 5/3 air drive.
55305	Tube ports. 3/8" SAE inlet and outlet. For 1.5 hp to 2 hp pumps. 15 pump minimum.
55516	Polyurethane ("W") seal. For ForTV series pumps, except high output models.
55630	Stainless steel (AISI-316) distance piece. For 1.5 hp to 2 hp pumps.
59353	Noise reduction kit fitted. Not available on AFD, DFD, ASFD or DSFD.
82460	HNBR seals in air drive section.
82500	ATEX modification (not available on AIV or DSXHW pumps).
82998	3/8" High pressure outlet converts medium ratio 10-122 outlet 1/2" port to high pressure port.
86337	Extended life air drive.

## 1.5 hp (1.12 kW) High Output Flow Pumps

Available in a choice of 3 models, these high output, low ratio pumps are capable of pressures to 1200 psi (82 bar) and flow rates of up to 22 gpm (83 l/min). These are "lift" pumps whereby the outlet pressure equals the air drive x the pump ratio plus the inlet pressure.

Model DSTV-1.5 has a maximum air drive of 150 psi (10 bar) and is capable of pressures up to 160 psi (11 bar). The model ATV and DTV-4 work on a maximum air drive of 150 psi (10 bar) and have a maximum pressure rating of 1200 psi (83 bar). A noise reduction modification is available for applications where noise level is an issue.

## Distance Piece (Separation)

Pumps with prefix "D" in the model number have aluminum distance piece between the air drive and pump section (except DSTV-1.5). Vent holes can be threaded 1/2" NPT female at extra cost. Specify modification number 28000. Horizontal mounting is recommended for non-exchange of contaminants.

## Mounting Brackets

All series mounting brackets have 7/16" holes (slots) for 3/8" bolts. Upper mounting brackets are not furnished as standard on single air head non-distance piece units.

### Dimensional Data

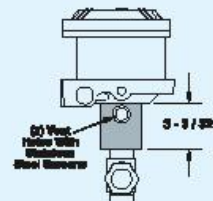

### Mounting Brackets

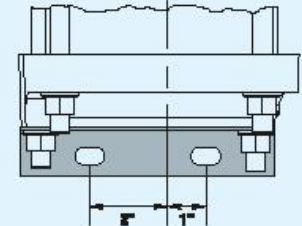

## Optional Pump Inlets for Tank Mounting

To specify ratios -10, -15, -22 or -32, add "BR" between the model number and the ratio, e.g. AUV-BR10.

Inlet externally threaded 1 1/4" NPT male  
Internally threaded 1" NPT female

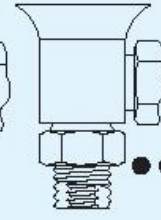
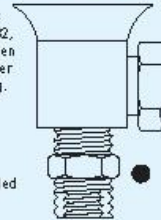

To specify ratios -25 through -903, add "B" between the model number and the ratio, e.g. AUV-B25.

Inlet on the bottom and externally threaded 1" NPT male  
Internally threaded 1/2" NPT female

Drive inlet and exhaust are 1/2" NPT female. Drive inlet also includes a 1/2" NPT male x 1/8" NPSM female (straight pipe thread) swivel adapter (connecting male nipple should include 30° inside bevel for proper fit).



## 2 & 2.2 hp (1.49 & 1.64 kW) Pump Models



### Key Features

- Choice of 16 models, 13 ratios, 46 possible combinations
- Output pressures to 100000 psi (7000 bar)
- Flows to 5 gpm (15 l/min)
- Choice of wetted materials
- Double and triple air heads
- Drive pressure 3 to 100 psi (.2 to 7 bar)

Model	Nominal Ratio	Maximum Working Pressure	Displacement per Cycle
AW, ASF, DF, DSF, DSTV	-B22	3200 psi (221 bar)	4 eu in (66.4 m)
	-B32	4800 psi (331 bar)	2.7 eu in (44.3 m)
	-S2	8000 psi (552 bar)	1.6 eu in (26.6 m)
	-T2	11000 psi (758 bar)	1.2 eu in (19 m)
	-122	19000 psi (1310 bar)	.7 eu in (11 m)
HF, HSF, DHF, DSHF	-202	33000 psi (2275 bar)	4 eu in (6.7 m)
	-302	50000 psi (3448 bar)	28 eu in (4.5 m)
DXHF, DSXHF	-452	70000 psi (4827 bar)	.18 eu in (3.0 m)
	-602	75000 psi (5171 bar)	.14 eu in (2.3 m)
DXHF, DSXHF	-683	70000 psi (4827 bar)	.18 eu in (3.0 m)
	-803	75000 psi (5171 bar)	.14 eu in (2.3 m)
DSXHW	-1373	100000 psi (6895 bar)	.09 eu in (1.4 m)
AFD, DSFD, DFD, ASFD	-860	6500 psi (448 bar)	1.3 eu in (22 m)

For service codes, see page 17.

For weights and dimensions, see page 20.

## 3 hp (2.24 kW) Pump Models



### Key Features

- One model available in 8 ratios
- Output pressures to 33000 psi (2275 bar)
- Flow rates to 8 gpm (30 l/min)
- Single air head
- Drive pressure 3 to 150 psi (.2 to 10 bar)

Model	Nominal Ratio	Maximum Working Pressure*	Displacement per Cycle
ASFD	10	1600 psi (110 bar)	8.1 eu in (132.8 m)
	15	2400 psi (165 bar)	5.4 eu in (88.6 m)
	25	4000 psi (275 bar)	3.3 eu in (53.2 m)
	35	5700 psi (393 bar)	2.3 eu in (38 m)
	60	9800 psi (676 bar)	1.3 eu in (22 m)
	100	16500 psi (1138 bar)	.8 eu in (13.4 m)
	150	20000 psi (1379 bar)	.5 eu in (9 m)
	202	33000 psi (2275 bar)	.8 eu in (13.4 m)

\* Continuous/Intermittent

For service codes, see page 17.

For weights and dimensions, see page 21.

**Optional Modifications (for 2 hp, 2.2 hp and 3 hp pump models)**

Number	Description	Number	Description
-C	Air controls (filter, regulator, gauge, shut-off). 3/4" NPT.	51050	Extreme service cycling modification. Not recommended for long stall periods.
-CP	Air controls with precision regulator. 3/4" NPT.	51056	Exhaust/pilot vent combiner.
-C0	Air controls with recycle button. 3/4" NPT.	51331	EPR (Ethylene propylene) static seals in wetted section. Applies to distance piece pumps only.
-CP0	Air controls with precision regulator and recycle button. 3/4" NPT.	51345	Sour gas drive provision to N.A.C.E. specifications. 1.5 hp to 2.2 hp distance piece pumps only, single air head and double air head.
-B	Bottom Inlet (designate "B" before ratio dash number, "BR" on -B10, -B15, -B22 and -B32) 1.5 hp and 2 hp pumps (not applicable to high output, chemical, 2.2 hp, or AWD series pumps)	52788	Viton seals. Air drive only - 1.5 hp to 2.2 hp pumps only.
16821	Low air pressure control feature. For operating at air pressures as low as 3 to 4 psi (.2 to .3 bar).	53825	Severe Arctic low temperature service. -25, -35, -60, -100, -150, -151, -225, -300, -450 ratios except 3 hp pump.
16831	Low temperature modification. For special sealing in air drive for operating temperatures from as low as -20°F up to normal +120°F.	54885	Rotate pump body 90° from standard. Except 3 hp pump.
16834	Exhaust adapter. With back pressure balance piston.	54935	SS trim for 5/3 air drive.
17860	Electrical stroke counter provision. Includes BZES-2RQ microswitch.	55191	Mounting ring kit for AWD series.
25721	Mechanical stroke counter. Installed (6 digit).	55192	3/4 NPT inlet port installed on AWD series (in place of threaded port).
27964	Interconnecting inlet-outlet tubing. 3/4" female for 4:1 ratio series pumps (ATV-4 or DTV-4).	55193	Extra foot bracket installed.
28000	Threaded vent (or purge) ports on standard distance piece. Except 1.5:1 ratio and 3 hp pump.	55305	Tube ports. 3/4" SAE inlet and outlet - for 1.5 hp to 2 hp pumps, 15 pump minimum.
28003	Test port. Provides access port in pump's body between inlet and outlet check valves for 1.5 hp and 2 hp pumps, -10 ratio or higher, single acting.	55465	Ceramic Plunger-60 Ratio.
28881	Air pilot modification. 1/2" NPT - Allows remote start/stop of pump.	55516	Polyurethane "W" seal in "F" series pumps-except high output models.
29376	Three-way cycling spool. For 1.5 hp and 2 hp single acting pumps.	55630	Stainless steel (SS-316) distance piece - for 1.5 thru 2 hp pumps.
29702	Single stroke modification. Except 3 hp pump.	59353	Noise reduction kit fitted. Not available on AFD, DFD, ASFD or DSFD.
29806	Double distance piece. For 1.5 hp and 2 hp pumps only, except 1.5:1 ratio.	59888	Cycle timer installed.
		82460	HNBR Seals in air drive section.
		82500	ATEX modification (not available on AIV or DSXHW pumps).
		86337	Extended life air drive.



## 6 hp (4.47 kW) Pump Models



### Key Features

- Choice of 10 models, 4 ratios, 20 possible combinations
- Output pressures to 10000 psi (690 bar)
- Flow rates to 21 gpm (80 l/min)
- Choice of wetted materials
- Single air head – double acting
- Drive pressure 3 to 125 psi (.2 to 9 bar)
- All hydraulic fluids, water (plain or DI), solvents

Model	Nominal Ratio	Maximum Working Pressure	Displacement per Cycle
GWD, GSFD, DGSFD <sup>(1)</sup> , DGSFD <sup>(1)</sup> , DGSTVD <sup>(1)</sup>	-12	4000 psi (276 bar)	159 cu in (260 m l)
GW, GSF, DGF, DGSF, DGSTV	-35 -60 -100	4375 psi (302 bar) 7500 psi (517 bar) 10000 psi (690 bar)	6.0 cu in (98 m l) 3.5 cu in (57 m l) 2.1 cu in (34.5 m l)

(1) Double Acting "Lift" Pumps

*For service codes, see page 17.  
For weights and dimensions, see page 22.*

Incorporating 10 models, this heavy duty range of double acting pumps provide pressures up to 10000 psi (690 bar) and flow rates up to 4 gpm (15 l/min).

Designed to operate with air drive pressures between 40 and 125 psi (2.8 and 9 bar). For drive pressures 3 to 40 psi (.2 to 2.8 bar), order 51875-1 mod.

## 8 hp (5.97 kW) Pump Models



### Key Features

- Choice of 6 models, 5 ratios, 9 possible combinations
- Pressures to 22500 psi (1530 bar)
- Flow rates to 11.5 gpm (44 l/min)
- All hydraulic fluids, water (plain or DI), solvents, liquefied gases
- Choice of wetted materials
- Single air head – double acting
- Drive pressure 3 to 125 psi (.2 to 9 bar)

Model	Nominal Ratio	Maximum Working Pressure	Displacement per Cycle
8SFD, 8DFD, 8DSFD, 8DSTVD, 8FD	-25 <sup>(1)</sup>	4000 psi (276 bar)	14 cu in (229 m l)
8SFD 8DSFD	40 65 -100 <sup>(1)</sup>	6000 psi (408 bar) 10000 psi (690 bar) 10000 psi (690 bar)	9 cu in (145.3 m l) 5.4 cu in (88.2 m l) 3.5 cu in (57.5 m l)
8HSFD	-22.9 <sup>(1)</sup>	22500 psi (1530 bar)	1.6 cu in (25.5 m l)

(1) Double Acting "Lift" Pumps

*For service codes, see page 17.  
For weights and dimensions, see page 23.*

## 10 hp (7.46 kW) Pump Models



Model	Nominal Ratio	Maximum Working Pressure	Displacement per Cycle
D14 STD	125 <sup>PSI</sup> 315 <sup>PSI</sup>	16000 psi (1103 bar) 36000 psi (2482 bar)	8.8 cu in (144.2 ml) 3.5 cu in (57.4 ml)
D14 SFD	125 <sup>PSI</sup> 315 <sup>PSI</sup>	16000 psi (1103 bar) 36000 psi (2482 bar)	8.8 cu in (144.2 ml) 3.5 cu in (57.4 ml)

(1) Double Acting "Lift" Pumps

For service codes, see page 17.  
For weights and dimensions, see page 23.

### Key Features

- Choice of 4 models, 4 ratios, 4 possible combinations
- Pressures to 36000 psi (2500 bar)
- Flow rates to 3 gpm (11 l/min)
- Drive pressure 3 to 125 psi (.2 to 9 bar)
- All hydraulic fluids, water (plain or DI), solvents, liquefied gases
- Choice of wetted materials

Incorporating two basic models, this heavy duty range of double acting pumps provide pressures up to 36000 psi (2482 bar) and output flow rate up to 3 gpm (11 l/min).

Operating from a maximum air drive pressure of 125 psi (9 bar), these pumps are designed for medium to high pressure service with minimum maintenance.

These large, slow speed pumps approach a seal life as high as 5 times that of many smaller pumps and this advantage becomes ever greater in heavy duty service involving water, or other liquids with negligible lubricity.

### Optional Modifications (for 6 hp, 8 hp and 10 hp pump)

Number	Description
C	Air controls.
17860	Electrical stroke counter provision (includes BZ55-2RQ micro switch).
25721	Mechanical stroke counter installed (5 digit).
29077	Interconnecting tubing – 6 hp and 8 hp pumps, double ended.
29077-1	Interconnecting tubing – 6 hp and 8 hp pumps, double ended low ratio pumps.
29078	Same as 29077, 29077-1 double ended w/distance piece.
29078-1	Same as 29077, 29077-1 double ended w/distance piece low ratio pumps.
29079	Interconnecting tubing – 10 hp pumps.
29125	External pilot modification – for 6 hp thru 10 hp pumps.
51875-1	Low air pressure control – for 6 hp thru 10 hp pumps.
54030	Sour gas air drive provision to NACE spec. 6 hp distance piece pumps only.

Number	Description
54312	Extreme service cycling modification – for 6 hp thru 10 hp pumps.
54336	Exhaust/pilot vent combiner.
55330	Interconnecting tubing 8D SFD-100 low pressure inlet.
55330-1	Interconnecting tubing 8D SFD-100 high pressure inlet.
55366	Interconnecting tubing 8D SFD-225.
57002	Witon seals – air drive only – 6 hp.
57944	Witon seals – air drive only – 8 hp.
59888	Cycle timer installed.
82900	ATEX modification available for 6 hp only, not available on 8 hp or 14 hp drive, no non GWS, GSE, DGSF, 6 SFD, or D6 SFD models.
86337	Extended life air drive.



## Power System Specialists

World safety standards and quality demands are rising. Component manufacturers are required to provide test certification and product quality assurance which can only be determined using the types of systems which Haskel can provide. Typically, we have built systems for production and field testing the proof, leak, and burst aspects of hoses, cylinders, and valves.

These systems can be portable, mobile, or static test rigs. We also offer a range of standard pressure packs used for power jacking, clamping, and other applications where reliable power is needed.

## Selecting Your Accessories

Haskel can either provide accessories separately or supply them fitted to form a complete package suited to your application. Additionally, Haskel can fit customer nominated accessories. Our accessories catalog is available and our technical support team is always ready to advise you on the most suitable choice of accessories for your application.

- Air pilot switches
- Air pilot valves
- Regulating relief valves
- Directional control and release valves
- Hydraulic accumulators, gas receivers and storage cylinders
- High pressure valves, fittings and tubing
- Plenum chambers
- Port adapters
- Pressure regulators
- Gauge snubbers
- Filters
- Stainless steel check valves
- Intensifiers with integral checks for cycling
- Capillary type gauge snubbers

## Quality and After-Sale Service



Haskel meets the requirements of international quality assurance ISO 9001. Build quality is matched by an innovative design and problem solving ability which stems from years of years of experience. Our representatives around the world are carefully chosen and trained to help you arrive at a correct product choice, and to offer a maintenance and parts service that is second to none.

*Please ask for your copy of our latest accessories brochure.*



## Liquids Compatible with Haskel Pumps

To assist in easier pump selection, we have classified various popular liquids in groups and assigned to each group a service code. These service code numbers are featured in the chart to the right and are designated for each pump series. Seals and other wetted materials can be supplied to suit your preferred liquid. For advice, please contact our technical services personnel at 818-843-4000.

### Services

#### Service Codes

- 1** Petroleum-based oils, kerosene, water with 5% soluble oil.
- 2** Plain water, diesel fuel.
- 3** Most phosphate ester-based fire-resistant hydraulic fluids, e.g. Pydraul, Lindol, Cellulube, Fyrquel, and Houghtosafe 1120 and petroleum-based solvents compatible with UHMWPE (Ultra-high Molecular Weight Polyethylene) dynamic seals and Viton static seals.
- 4** Petroleum-based solvents, e.g. boron fuels, aromatic hydrocarbons (benzene, toluene, xylene, hylene, etc.); chlorinated solvents (trichlorethylene, carbon tetrachloride, chlorobenzene, etc.); mercaptans, Dowtherm A, fluorinated solvents (fluorobenzene, fluorochlorethylene, etc.); Dowtherm E, plus all of Group 3 and some mildly corrosive acids compatible with wetted materials. See note 5A for service with methyl-ethyl-ketone, methyl acetone, diacetone, alcohol and freon 22.
- 5** Skydrol and Aerosafe hydraulic fluid; acetone and some alcohols (ethyl, methyl, and isopropyl).
- 5A.** Also suitable for these fluids if Viton static seals are replaced with EPR; specify modification number 51331 (no extra charge); e.g., 51331-MDTV-5. Most phosphate ester-based fluids solidify at approximately 30000 psi.
- 6** Deionized water; demineralized water.

**Note:** Dynamic seal life with non-lubricating fluids will understandably be less than with lubricating types.

### Operating Temperatures

#### Drive Section

-4° (25°F) to +65°C (150°F) (low temperature seals are available for Arctic operation).

#### Liquid Section

For reasonable seal life, high temperature should be limited to 54° C (130° F), for F and W seal models, 135° C (275° F) for T and TV models (with distance piece).

hp	Model	Services						
		1	2	3	4	5	5A	6
.33	M	•						
	MS	•	•					
	MDTV	•		•			•	
	MDSTV	•	•	•	•		•	
	MCPV	•	•	•	•	•		
29723		•	•	•		•	•	
.75	4B -14 to -37	•						
	4B -55 to -150	•	•					
1.5 2 2.2	AW	•						
	ASF	•	•					
	DF	•		•			•	
	DSF	•	•	•			•	•
	HF	•						
	HSF	•	•					
	DHF	•					•	
	DSHF	•	•				•	•
	DSTV	•	•	•	•		•	
	ATV	•	•					
	DTV	•					•	
	DSTV -1.5	•	•	•	•		•	•
	AFD	•						
	DFD	•		•			•	
ASFD	•	•						
DSFD	•	•	•			•	•	
DXHF	•					•		
DSXHF	•	•				•	•	
DSXHW	•	•						
3	ASFD	•	•					
6	GW	•						
	GSF	•	•					
	DGF	•		•			•	
	DGSF	•	•	•			•	•
	DGSTV	•	•	•	•		•	
	GWD	•						
	GSFD	•	•					
	DGFD	•		•			•	
	DGSFD	•	•	•	•		•	•
DGSTVD	•	•	•	•		•		
8	8FD	•						
	8SFD	•	•	•	•		•	
	8DFD	•						
	8DSFD	•	•					
	8DSTVD	•		•			•	
8HSFD	•	•	•	•		•		
10	D14STD -125	•	•	•	•		•	
	D14STD -315	•	•	•	•		•	
	D14SFD -125	•	•	•			•	•
	D14SFD -315	•	•	•			•	•

# Weights and Dimensions

## .33 hp (.25 kW) M Series Pump Models

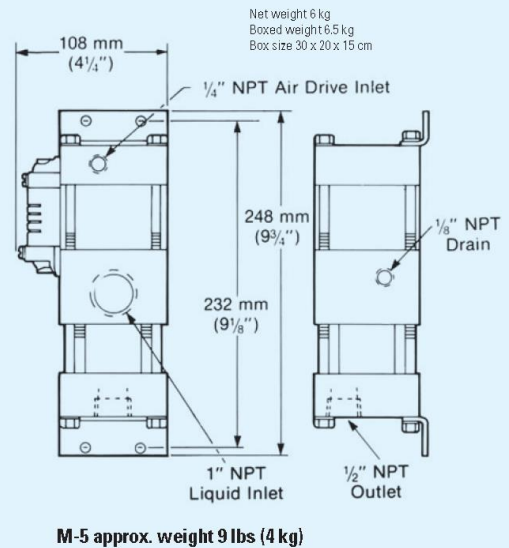
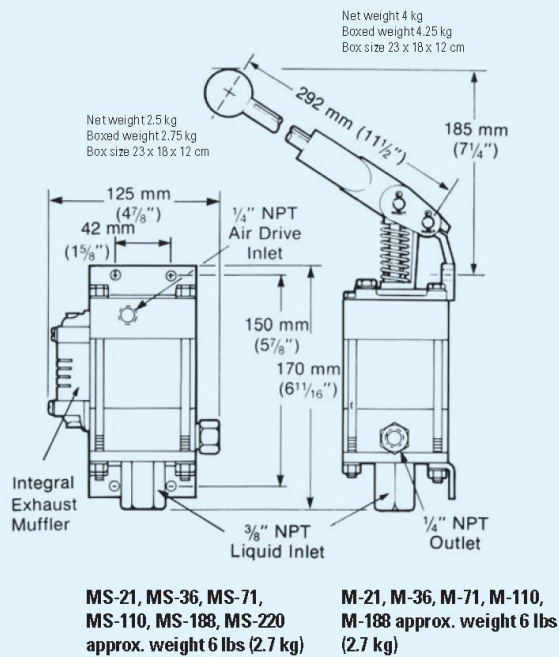
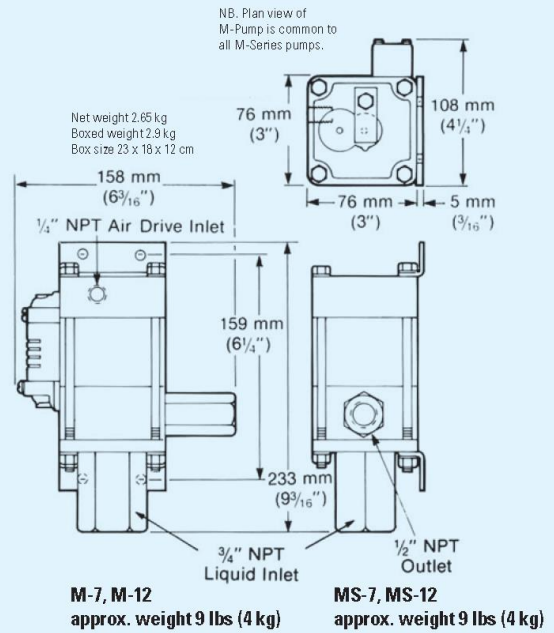

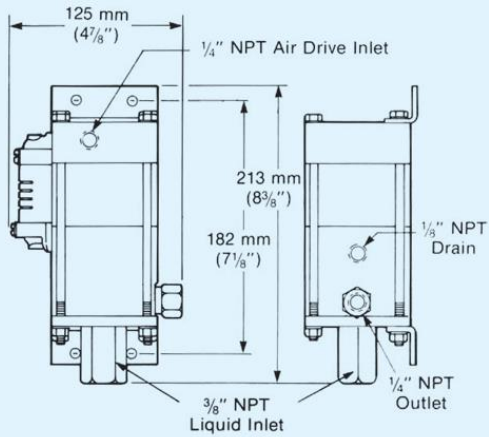

29723-21, 29723-36, 29723-71, 29723-110  
approx. weight 6.5 lbs (3 kg)

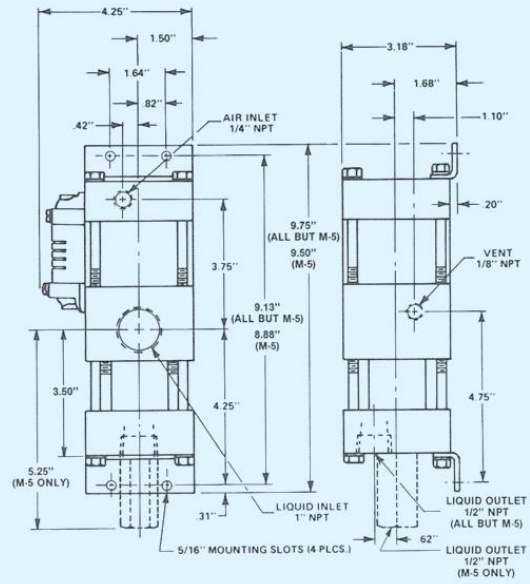

MDSTV-5  
Approx weight 15 1/2 lbs (7 kg)

**.75 hp (.56 kW) Pump Models**

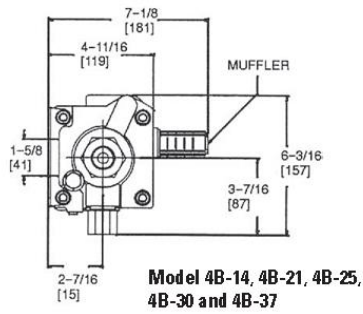

Model 4B-14, 4B-21, 4B-25,  
4B-30 and 4B-37

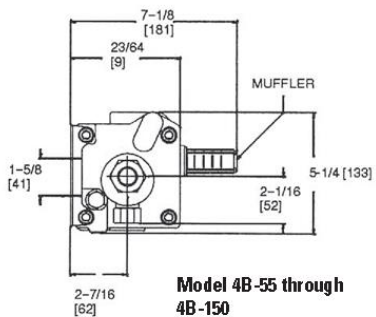
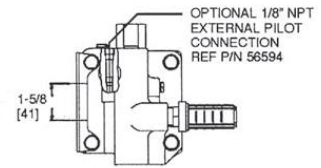
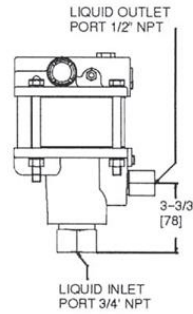
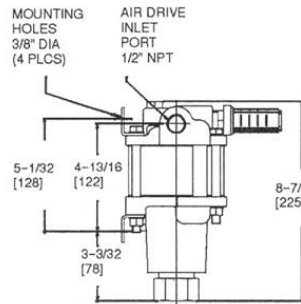

Model 4B-55 through  
4B-150

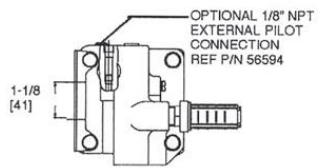
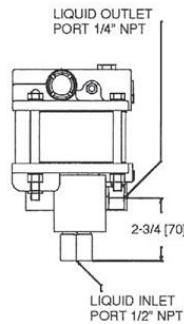
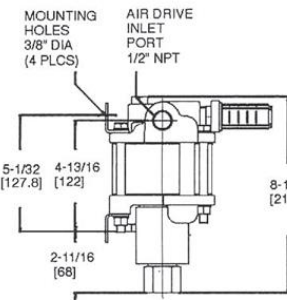

## 1.5 hp, 2 & 2.2 hp (1.12, 1.49 & 1.64 kW) Pump Models

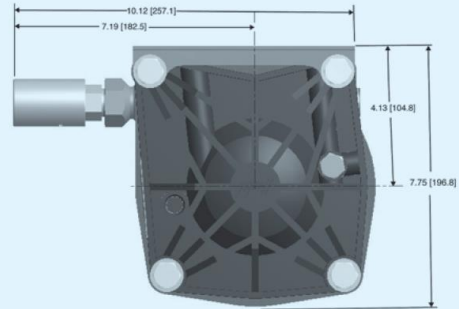
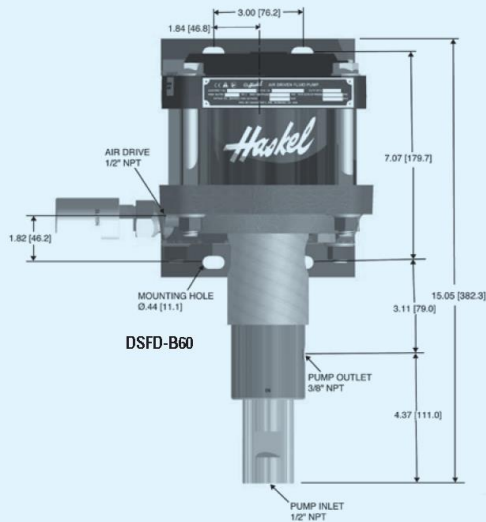

Net weight 18 kg  
Boxed weight 20 kg  
Box size 68 x 42 x 50 cm

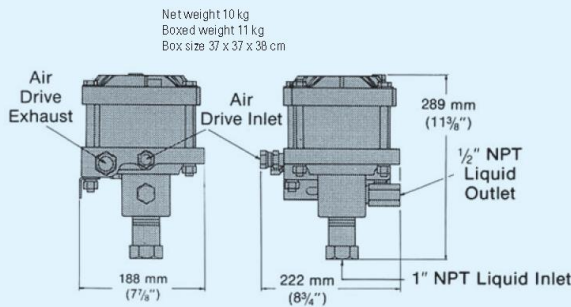

**1.5 and 2 hp low ratio pumps;  
-B10 and -B15 ratios**

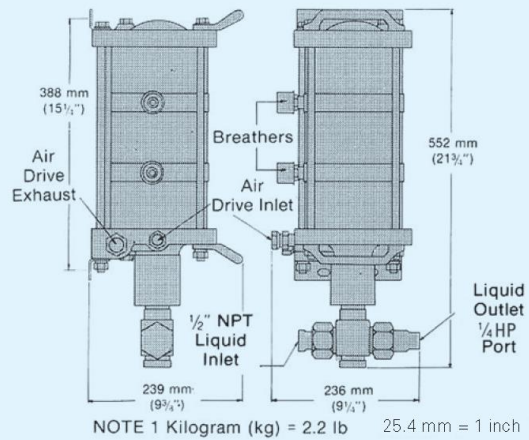

**1.5 and 2 hp high ratio pumps;  
-683 and -903 ratios**

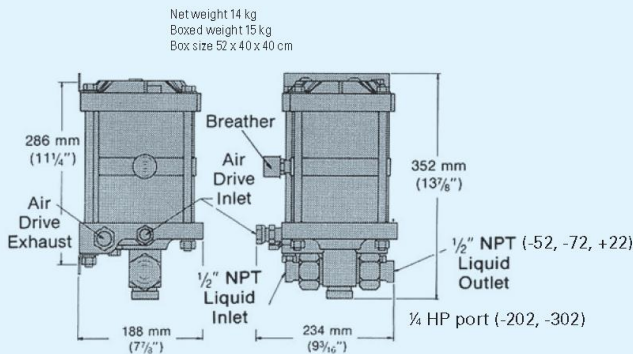

**1.5 and 2 hp medium ratio pumps;  
-52, -72, -122, -202 and -302 ratios**

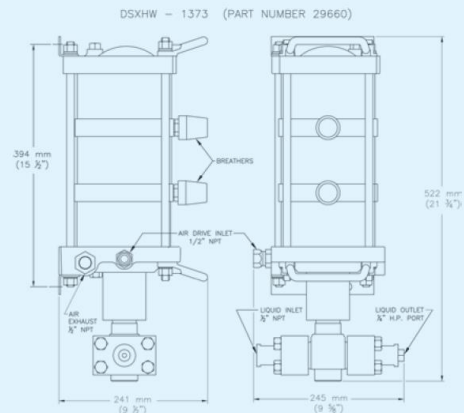

**2 & 2.2 hp (1.49 & 1.64 kW) Pump Models**

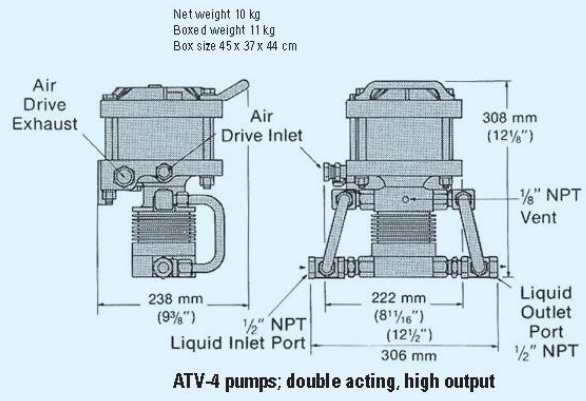
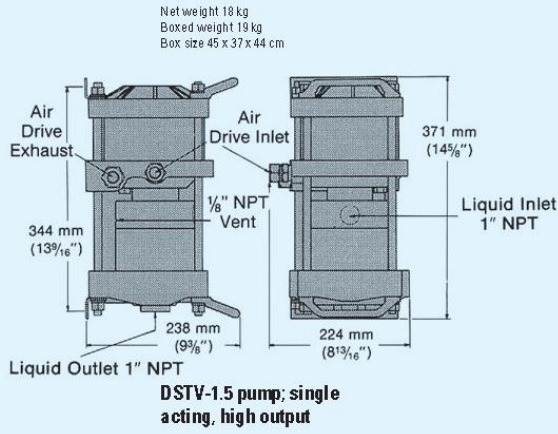

Note: For model DTV-4, add distance piece dimension from page 11. Interconnecting inlet and outlet port tubing shown.

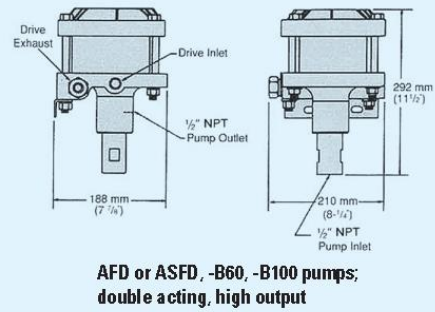
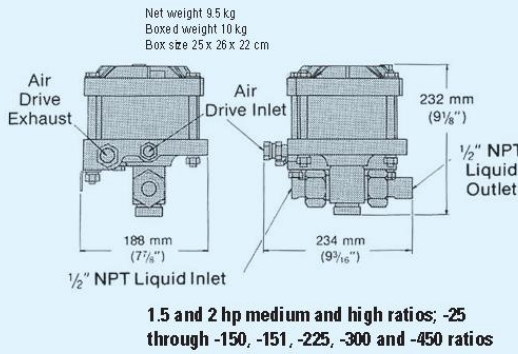

**3 hp (2.24 kW) Pump Models**

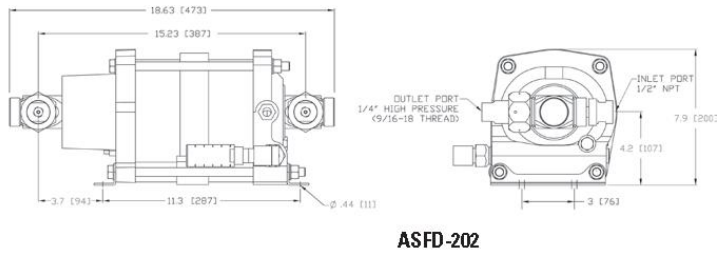
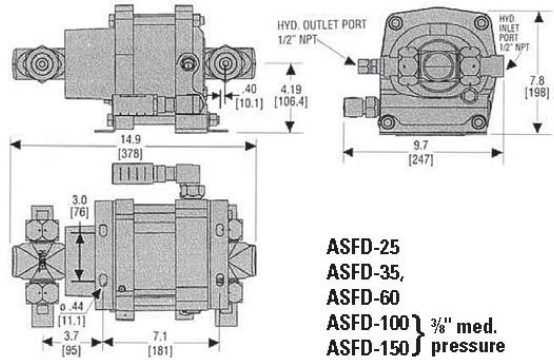
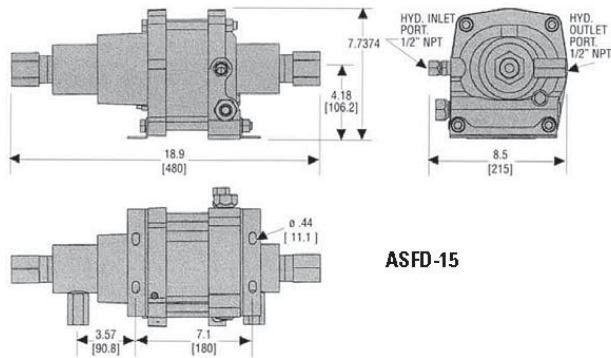

## 6 hp (4.47 kW) Pump Models

Net weight 31 lbs (14 kg)  
 Boxed weight 35 lbs (16 kg)  
 Box size 52 x 39 x 39 cm

All models have 2 off 1/4" NPT air exhaust ports and 1 off 3/4" NPT air drive inlet ports.

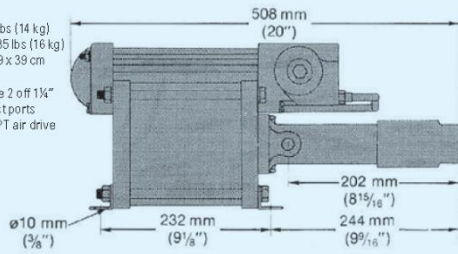

**Models GW, GSF nominal ratio 35, 60 100:1**

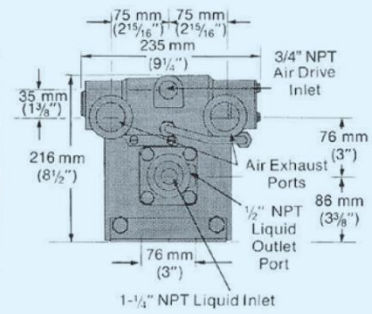

Net weight 41 lbs (18.5 kg)  
 Boxed weight 48 (22 kg)  
 Box size 66 x 41 x 49 cm

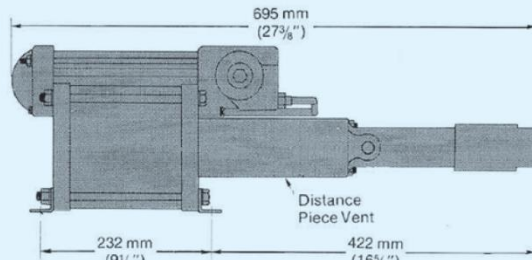

**Models DGF, DGSE, DGSTV nominal ratio 35, 60 100:1**

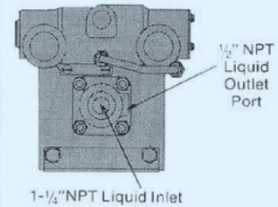

End dimensions as GW/GSF

Net weight 57 lbs (26 kg)  
 Boxed weight 61 (27 kg)  
 Box size 66 x 41 x 49 cm

If interconnecting piping for the two inlets and two outlets is required, specify modification 29077 with your order.

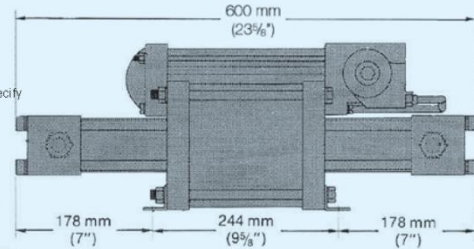
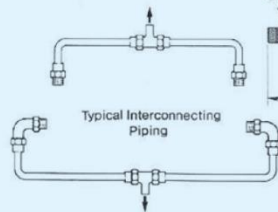

**Models GWD, GSF nominal ratio 12:1**

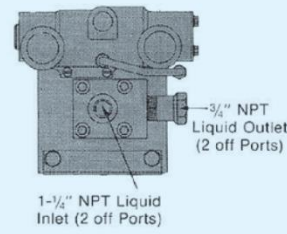

End dimensions as GW/GSF

Net weight 66 lbs (30 kg)  
 Boxed weight 75 lbs (34 kg)  
 Box size 91 x 51 x 39 cm

If interconnecting piping for the two inlets and two outlets is required, specify modification 29078 with your order.

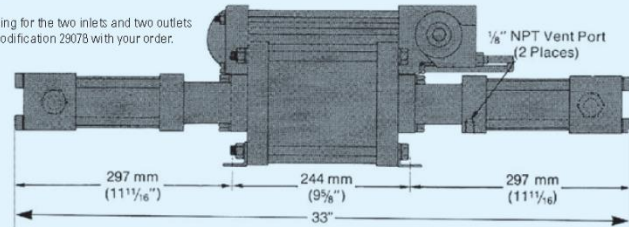

**Models DGFD, DGSFD, DGSTVD nominal ratio 12:1**

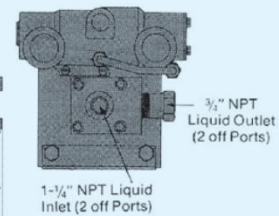

## 8 hp (5.97 kW) Pump Models

Model	Length	Width	Height	Weight	Air Drive	Liquid Inlet	Liquid Outlet
8FD-25 8SFD-25	25 3/4" (644.5 mm)	9 1/2" (241 mm)	11" (279 mm)	80 lbs (36 kg)	3/4"	1 1/4" NPT <sup>(2)</sup>	3/4" NPT <sup>(2)</sup>
8DFD-25 8DSFD-25 8DSTVD-25	34 3/4" (883 mm)	9 1/2" (241 mm)	11" (279 mm)	94 lbs (43 kg)	3/4"	1 1/4" NPT <sup>(2)</sup>	3/4" NPT <sup>(2)</sup>
8SFD-40	26 7/8" (683 mm)	9 1/2" (241 mm)	11" (279 mm)	64 lbs (29 kg)	3/4"	1" NPT	3/8" NPT
8SFD-65	26 7/8" (683 mm)	9 1/2" (241 mm)	11" (279 mm)	63 lbs (28.5 kg)	3/4"	1" NPT	1/2" NPT
8HSFD-225	28 3/4" (721)	9 1/2" (241 mm)	11" (279 mm)	71 lbs (32 kg)	3/4"	3/8" M/P (20K coned and threaded connection)	3/8" M/P (20K coned and threaded connection)
8DSFD-100	41 3/4" (1060 mm)	9 1/2" (241 mm)	11" (279 mm)	92 lbs (42 kg)	3/4"	1 1/4" NPT <sup>(2)</sup>	3/4" NPT <sup>(2)</sup>

## 10 hp (7.46 kW) Pump Models

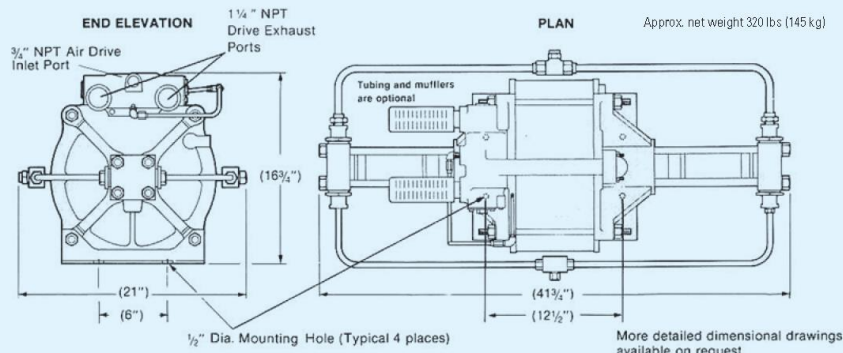

Note: See 29079 interconnecting tubing optional page 15. (29079 shown)  
 Single Inlet port – 3/4 JIC male flare connection, single outlet port 3/4 HP ports (BuTech).  
 Individual Pump ports – Liquid inlets 2 ea. 1/2 NPT ports, 2 ea. 3/4 HP ports (BuTech)

CELEBRATING OVER 80  
YEARS OF HYDRAULIC AND  
PNEUMATIC ENGINEERING  
EXPERIENCE IN THE DESIGN  
AND MANUFACTURING  
OF HIGH PRESSURE  
GENERATING EQUIPMENT  
AND CONTROLS



QMS225  
EMSS11920

**Haskel International, Inc.**

100 East Graham Place  
Burbank, California 91502 USA  
Tel: 818-843-4000 / Fax: 818-566-2649 or 818-841-4291  
[www.haskel.com](http://www.haskel.com)

**Haskel Europe Ltd.**

North Hylton Road  
Sunderland SR5 3JD, England, UK  
Tel: 44-191-549-1212 / Fax: 44-191-549-0911  
[www.haskel-europe.com](http://www.haskel-europe.com)

**Haskel Middle East**

Hamilton Sundstrand Industrial MIE FZE  
P.O. Box 262384 Jebel Ali, Dubai, United Arab Emirates  
Tel: +971 4886 2686 / Fax: +971 4886 2687  
Email: [sales@haskel.ae](mailto:sales@haskel.ae)

**Haskel Asia**

Hamilton Sundstrand Singapore Industrial Pte. Ltd.  
23 Tagore Lane #03-06  
Tagore 23 Warehouse Complex, Singapore 787601  
Tel: 65-6455-7689 / Fax: 65-6455-2841  
[www.haskel.com.sg](http://www.haskel.com.sg)

For further information on Haskel  
products, please visit us online at  
[www.haskel.com](http://www.haskel.com)



REVISIONS  
 1. NEW DESIGN  
 2. DIMENSIONS MAY VARY TO BE APPROVED BY THE CUSTOMER  
 3. SEE SHEET 1

INLET CHECK VALVE  
 M-50

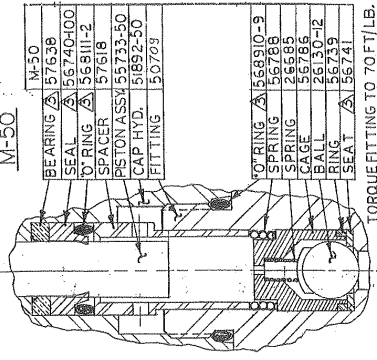

- BEARING M-50 157639
- SEAL 56740-00
- O-RING 56811-2
- SPACER 157618
- PISTON ASSY 15733-50
- CAP HYD. 5692-50
- FITTING 50709
- TOR RING 56890-9
- SPRING 56788
- SPRING 26685
- CAGE 56786
- BALL 26130-12
- RING 56739
- SEAT 56741

TORQUE FITTING TO 70 FT/LB.

CONTRACT NO. TITLE DATE DRAWN BY CHECKED BY APPROVED BY	Hatched 1000 1/2" DIA. 1/2" DIA. 1000 1/2" DIA. 1/2" DIA. 1000 1/2" DIA. 1/2" DIA. 1000 1/2" DIA. 1/2" DIA. 1000 1/2" DIA. 1/2" DIA. 1000 1/2" DIA. 1/2" DIA.	ASSEMBLY DRAWING MODEL "M" PUMP
PART NO. QTY. UNIT	81400 1 1	28550 1 1



## **APPENDIX III**

### **Safety Data Sheet MIL-PRF-5606 Hydraulic Fluid**





Product Name: MOBIL AERO HFA  
Revision Date: 01 Oct 2015  
Page 1 of 12

## SAFETY DATA SHEET

### SECTION 1 PRODUCT AND COMPANY IDENTIFICATION

#### PRODUCT

**Product Name:** MOBIL AERO HFA  
**Product Description:** Base Oil and Additives  
**Product Code:** 201550401020, 490110-00, 970584  
**Intended Use:** Aviation hydraulic oil

#### COMPANY IDENTIFICATION

**Supplier:** EXXON MOBIL CORPORATION  
22777 Springwoods Village Parkway  
Spring, TX. 77253 USA  
**24 Hour Health Emergency** 609-737-4411  
**Transportation Emergency Phone** 800-424-9300 or 703-527-3887 CHEMTREC  
**Product Technical Information** 800-662-4525  
**MSDS Internet Address** <http://www.exxon.com>, <http://www.mobil.com>

### SECTION 2 HAZARDS IDENTIFICATION

This material is hazardous according to regulatory guidelines (see (M)SDS Section 15).

#### CLASSIFICATION:

Flammable liquid: Category 4.  
Aspiration toxicant: Category 1.

#### LABEL:

Pictogram:



**Signal Word:** Danger

#### Hazard Statements:

H227: Combustible liquid. H304: May be fatal if swallowed and enters airways.

#### Precautionary Statements:

P210: Keep away from flames and hot surfaces. -- No smoking. P273: Avoid release to the environment. P280: Wear protective gloves and eye / face protection. P301 + P310: IF SWALLOWED: Immediately call a POISON CENTER or doctor/physician. P331: Do NOT induce vomiting. P370 + P378: In case of fire: Use water fog, foam, dry chemical or carbon dioxide (CO2) to extinguish. P403 + P235: Store in a well-ventilated place. Keep cool. P405: Store locked up. P501: Dispose of contents and container in accordance with local regulations.



Product Name: MOBIL AERO HFA  
 Revision Date: 01 Oct 2015  
 Page 2 of 12

**Other hazard information:**

**HAZARD NOT OTHERWISE CLASSIFIED (HNOC):** None as defined under 29 CFR 1910.1200.

**PHYSICAL / CHEMICAL HAZARDS**

Material can accumulate static charges which may cause an ignition. Material can release vapors that readily form flammable mixtures. Vapor accumulation could flash and/or explode if ignited. Combustible.

**HEALTH HAZARDS**

High-pressure injection under skin may cause serious damage. Excessive exposure may result in eye, skin, or respiratory irritation.

**ENVIRONMENTAL HAZARDS**

No significant hazards.

**NFPA Hazard ID:** Health: 1 Flammability: 2 Reactivity: 0  
**HMIS Hazard ID:** Health: 1\* Flammability: 2 Reactivity: 0

**NOTE:** This material should not be used for any other purpose than the intended use in Section 1 without expert advice. Health studies have shown that chemical exposure may cause potential human health risks which may vary from person to person.

**SECTION 3 COMPOSITION / INFORMATION ON INGREDIENTS**

This material is defined as a mixture.

**Hazardous Substance(s) or Complex Substance(s) required for disclosure**

Name	CAS#	Concentration*	GHS Hazard Codes
2,6-DI-TERT-BUTYL-P-CRESOL	128-37-0	0.1 - < 1%	H400(M factor 1), H410(M factor 1)
DISTILLATES (PETROLEUM), HYDROTREATED LIGHT	64742-47-8	5 - < 10%	H304
HYDROTREATED LIGHT NAPHTHENIC DISTILLATE (PETROLEUM)	64742-53-6	50 - < 70%	H227, H304
HYDROTREATED MIDDLE DISTILLATE (PETROLEUM)	64742-46-7	20 - < 30%	H304
TRIPHENYL PHOSPHATE	115-86-6	0.1 - < 0.25%	H400(M factor 1), H410(M factor 1)

\* All concentrations are percent by weight unless material is a gas. Gas concentrations are in percent by volume.

As per paragraph (i) of 29 CFR 1910.1200, formulation is considered a trade secret and specific chemical identity and exact percentage (concentration) of composition may have been withheld. Specific chemical identity and exact percentage composition will be provided to health professionals, employees, or designated representatives in accordance with applicable provisions of paragraph (i).

**SECTION 4 FIRST AID MEASURES**

**INHALATION**



Product Name: MOBIL AERO HFA  
Revision Date: 01 Oct 2015  
Page 3 of 12

Remove from further exposure. For those providing assistance, avoid exposure to yourself or others. Use adequate respiratory protection. If respiratory irritation, dizziness, nausea, or unconsciousness occurs, seek immediate medical assistance. If breathing has stopped, assist ventilation with a mechanical device or use mouth-to-mouth resuscitation.

#### SKIN CONTACT

Wash contact areas with soap and water. Remove contaminated clothing. Launder contaminated clothing before reuse. If product is injected into or under the skin, or into any part of the body, regardless of the appearance of the wound or its size, the individual should be evaluated immediately by a physician as a surgical emergency. Even though initial symptoms from high pressure injection may be minimal or absent, early surgical treatment within the first few hours may significantly reduce the ultimate extent of injury.

#### EYE CONTACT

Flush thoroughly with water. If irritation occurs, get medical assistance.

#### INGESTION

Seek immediate medical attention. Do not induce vomiting.

#### NOTE TO PHYSICIAN

If ingested, material may be aspirated into the lungs and cause chemical pneumonitis. Treat appropriately.

### SECTION 5 FIRE FIGHTING MEASURES

#### EXTINGUISHING MEDIA

**Appropriate Extinguishing Media:** Use water fog, foam, dry chemical or carbon dioxide (CO<sub>2</sub>) to extinguish flames.

**Inappropriate Extinguishing Media:** Straight Streams of Water

#### FIRE FIGHTING

**Fire Fighting Instructions:** Evacuate area. Prevent runoff from fire control or dilution from entering streams, sewers, or drinking water supply. Firefighters should use standard protective equipment and in enclosed spaces, self-contained breathing apparatus (SCBA). Use water spray to cool fire exposed surfaces and to protect personnel.

**Unusual Fire Hazards:** Combustible. Pressurized mists may form a flammable mixture.

**Hazardous Combustion Products:** Aldehydes, Incomplete combustion products, Oxides of carbon, Phosphorus oxides, Smoke, Fume, Sulfur oxides

#### FLAMMABILITY PROPERTIES

**Flash Point [Method]:** >82°C (180°F) [ASTM D-93]

**Flammable Limits (Approximate volume % in air):** LEL: 0.7 UEL: 7.0 [Estimated]

**Autoignition Temperature:** >225°C (437°F)

### SECTION 6 ACCIDENTAL RELEASE MEASURES

#### NOTIFICATION PROCEDURES

In the event of a spill or accidental release, notify relevant authorities in accordance with all applicable



Product Name: MOBIL AERO HFA  
Revision Date: 01 Oct 2015  
Page 4 of 12

regulations. US regulations require reporting releases of this material to the environment which exceed the applicable reportable quantity or oil spills which could reach any waterway including intermittent dry creeks. The National Response Center can be reached at (800)424-8802.

#### PROTECTIVE MEASURES

Avoid contact with spilled material. Warn or evacuate occupants in surrounding and downwind areas if required due to toxicity or flammability of the material. See Section 5 for fire fighting information. See the Hazard Identification Section for Significant Hazards. See Section 4 for First Aid Advice. See Section 8 for advice on the minimum requirements for personal protective equipment. Additional protective measures may be necessary, depending on the specific circumstances and/or the expert judgment of the emergency responders.

For emergency responders: Respiratory protection: respiratory protection will be necessary only in special cases, e.g., formation of mists. Half-face or full-face respirator with filter(s) for dust/organic vapor or Self Contained Breathing Apparatus (SCBA) can be used depending on the size of spill and potential level of exposure. If the exposure cannot be completely characterized or an oxygen deficient atmosphere is possible or anticipated, SCBA is recommended. Work gloves that are resistant to hydrocarbons are recommended. Gloves made of polyvinyl acetate (PVA) are not water-resistant and are not suitable for emergency use. Chemical goggles are recommended if splashes or contact with eyes is possible. Small spills: normal antistatic work clothes are usually adequate. Large spills: full body suit of chemical resistant, antistatic material is recommended.

#### SPILL MANAGEMENT

**Land Spill:** Eliminate all ignition sources (no smoking, flares, sparks or flames in immediate area). Stop leak if you can do it without risk. All equipment used when handling the product must be grounded. Do not touch or walk through spilled material. Prevent entry into waterways, sewer, basements or confined areas. A vapor suppressing foam may be used to reduce vapors. Use clean non-sparking tools to collect absorbed material. Absorb or cover with dry earth, sand or other non-combustible material and transfer to containers. Large Spills: Water spray may reduce vapor; but may not prevent ignition in closed spaces. Recover by pumping or with suitable absorbent.

**Water Spill:** Stop leak if you can do it without risk. Confine the spill immediately with booms. Warn other shipping. Remove from the surface by skimming or with suitable absorbents. Seek the advice of a specialist before using dispersants.

Water spill and land spill recommendations are based on the most likely spill scenario for this material; however, geographic conditions, wind, temperature, (and in the case of a water spill) wave and current direction and speed may greatly influence the appropriate action to be taken. For this reason, local experts should be consulted. Note: Local regulations may prescribe or limit action to be taken.

#### ENVIRONMENTAL PRECAUTIONS

Large Spills: Dike far ahead of liquid spill for later recovery and disposal. Prevent entry into waterways, sewers, basements or confined areas.

<b>SECTION 7</b>	<b>HANDLING AND STORAGE</b>
------------------	-----------------------------

#### HANDLING

Avoid contact with skin. Avoid prolonged breathing of mists and heated vapor. Prevent small spills and leakage to avoid slip hazard. Material can accumulate static charges which may cause an electrical spark (ignition source). When the material is handled in bulk, an electrical spark could ignite any flammable vapors from liquids or residues that may be present (e.g., during switch-loading operations). Use proper bonding and/or ground procedures. However, bonding and grounds may not eliminate the hazard from static



Product Name: MOBIL AERO HFA  
 Revision Date: 01 Oct 2015  
 Page 5 of 12

accumulation. Consult local applicable standards for guidance. Additional references include American Petroleum Institute 2003 (Protection Against Ignitions Arising out of Static, Lightning and Stray Currents) or National Fire Protection Agency 77 (Recommended Practice on Static Electricity) or CENELEC CLC/TR 50404 (Electrostatics - Code of practice for the avoidance of hazards due to static electricity).

**Static Accumulator:** This material is a static accumulator.

## STORAGE

The container choice, for example storage vessel, may effect static accumulation and dissipation. Keep container closed. Handle containers with care. Open slowly in order to control possible pressure release. Store in a cool, well-ventilated area. Storage containers should be grounded and bonded. Fixed storage containers, transfer containers and associated equipment should be grounded and bonded to prevent accumulation of static charge.

## SECTION 8 EXPOSURE CONTROLS / PERSONAL PROTECTION

### EXPOSURE LIMIT VALUES

Exposure limits/standards (Note: Exposure limits are not additive)

Substance Name	Form	Limit / Standard		NOTE	Source
2,6-DI-TERT-BUTYL-P-CRESOL	Inhalable fraction and vapor	TWA	2 mg/m <sup>3</sup>	N/A	ACGIH
DISTILLATES (PETROLEUM), HYDROTREATED LIGHT [total hydrocarbon vapor]	Non-Aerosol	TWA	200 mg/m <sup>3</sup>	Skin	ACGIH
HYDROTREATED LIGHT NAPHTHENIC DISTILLATE (PETROLEUM)	Mist.	TWA	5 mg/m <sup>3</sup>	N/A	OSHA Z1
HYDROTREATED LIGHT NAPHTHENIC DISTILLATE (PETROLEUM)	Inhalable fraction.	TWA	5 mg/m <sup>3</sup>	N/A	ACGIH
HYDROTREATED LIGHT NAPHTHENIC DISTILLATE (PETROLEUM)	Mist.	TWA	5 mg/m <sup>3</sup>	N/A	ACGIH
HYDROTREATED MIDDLE DISTILLATE (PETROLEUM)	Mist.	TWA	5 mg/m <sup>3</sup>	N/A	OSHA Z1
HYDROTREATED MIDDLE DISTILLATE (PETROLEUM)	Inhalable fraction.	TWA	5 mg/m <sup>3</sup>	N/A	ACGIH
TRIPHENYL PHOSPHATE		TWA	3 mg/m <sup>3</sup>	N/A	OSHA Z1
TRIPHENYL PHOSPHATE		TWA	3 mg/m <sup>3</sup>	N/A	ACGIH

**Exposure limits/standards for materials that can be formed when handling this product:** When mists/aerosols can occur the following are recommended: 5 mg/m<sup>3</sup> - ACGIH TLV (inhalable fraction), 5 mg/m<sup>3</sup> - OSHA PEL.

NOTE: Limits/standards shown for guidance only. Follow applicable regulations.

No biological limits allocated.

### ENGINEERING CONTROLS

The level of protection and types of controls necessary will vary depending upon potential exposure conditions.



Product Name: MOBIL AERO HFA  
Revision Date: 01 Oct 2015  
Page 6 of 12

---

Control measures to consider:  
Use explosion-proof ventilation equipment to stay below exposure limits.

## PERSONAL PROTECTION

Personal protective equipment selections vary based on potential exposure conditions such as applications, handling practices, concentration and ventilation. Information on the selection of protective equipment for use with this material, as provided below, is based upon intended, normal usage.

**Respiratory Protection:** If engineering controls do not maintain airborne contaminant concentrations at a level which is adequate to protect worker health, an approved respirator may be appropriate. Respirator selection, use, and maintenance must be in accordance with regulatory requirements, if applicable. Types of respirators to be considered for this material include:

No special requirements under ordinary conditions of use and with adequate ventilation.

For high airborne concentrations, use an approved supplied-air respirator, operated in positive pressure mode. Supplied air respirators with an escape bottle may be appropriate when oxygen levels are inadequate, gas/vapor warning properties are poor, or if air purifying filter capacity/rating may be exceeded.

**Hand Protection:** Any specific glove information provided is based on published literature and glove manufacturer data. Glove suitability and breakthrough time will differ depending on the specific use conditions. Contact the glove manufacturer for specific advice on glove selection and breakthrough times for your use conditions. Inspect and replace worn or damaged gloves. The types of gloves to be considered for this material include:

If prolonged or repeated contact is likely, chemical resistant gloves are recommended. If contact with forearms is likely, wear gauntlet style gloves.

**Eye Protection:** If contact is likely, safety glasses with side shields are recommended.

**Skin and Body Protection:** Any specific clothing information provided is based on published literature or manufacturer data. The types of clothing to be considered for this material include:

If prolonged or repeated contact is likely, chemical, and oil resistant clothing is recommended.

**Specific Hygiene Measures:** Always observe good personal hygiene measures, such as washing after handling the material and before eating, drinking, and/or smoking. Routinely wash work clothing and protective equipment to remove contaminants. Discard contaminated clothing and footwear that cannot be cleaned. Practice good housekeeping.

## ENVIRONMENTAL CONTROLS

Comply with applicable environmental regulations limiting discharge to air, water and soil. Protect the environment by applying appropriate control measures to prevent or limit emissions.

## SECTION 9

## PHYSICAL AND CHEMICAL PROPERTIES

**Note:** Physical and chemical properties are provided for safety, health and environmental considerations only and may not fully represent product specifications. Contact the Supplier for additional information.

## GENERAL INFORMATION

**Physical State:** Liquid  
**Color:** Red



Product Name: MOBIL AERO HFA  
 Revision Date: 01 Oct 2015  
 Page 7 of 12

**Odor:** Characteristic  
**Odor Threshold:** N/D

#### IMPORTANT HEALTH, SAFETY, AND ENVIRONMENTAL INFORMATION

**Relative Density (at 15 °C):** 0.88  
**Flammability (Solid, Gas):** N/A  
**Flash Point [Method]:** >82°C (180°F) [ASTM D-93]  
**Flammable Limits (Approximate volume % in air):** LEL: 0.7 UEL: 7.0 [Estimated]  
**Autoignition Temperature:** >225°C (437°F)  
**Boiling Point / Range:** N/D  
**Decomposition Temperature:** N/D  
**Vapor Density (Air = 1):** N/D  
**Vapor Pressure:** [N/D at 20 °C]  
**Evaporation Rate (n-butyl acetate = 1):** N/D  
**pH:** N/A  
**Log Pow (n-Octanol/Water Partition Coefficient):** N/D  
**Solubility in Water:** Negligible  
**Viscosity:** 13.8 cSt (13.8 mm<sup>2</sup>/sec) at 40 °C | 5.1 cSt (5.1 mm<sup>2</sup>/sec) at 100°C [ASTM D 445]  
**Oxidizing Properties:** See Hazards Identification Section.

#### OTHER INFORMATION

**Freezing Point:** N/D  
**Melting Point:** N/A  
**Pour Point:** -60°C (-76°F) [ASTM D97]  
**DMSO Extract (mineral oil only), IP-346:** < 3 %wt

### SECTION 10 STABILITY AND REACTIVITY

**REACTIVITY:** See sub-sections below.

**STABILITY:** Material is stable under normal conditions.

**CONDITIONS TO AVOID:** Open flames and high energy ignition sources.

**MATERIALS TO AVOID:** Strong oxidizers

**HAZARDOUS DECOMPOSITION PRODUCTS:** Material does not decompose at ambient temperatures.

**POSSIBILITY OF HAZARDOUS REACTIONS:** Hazardous polymerization will not occur.

### SECTION 11 TOXICOLOGICAL INFORMATION

#### INFORMATION ON TOXICOLOGICAL EFFECTS

Hazard Class	Conclusion / Remarks
<b>Inhalation</b>	
Acute Toxicity: No end point data for material.	Minimally Toxic. Based on assessment of the components.
Irritation: No end point data for material.	Elevated temperatures or mechanical action may form vapors, mist, or fumes which may be irritating to the eyes, nose, throat, or lungs.



Product Name: MOBIL AERO HFA  
 Revision Date: 01 Oct 2015  
 Page 8 of 12

<b>Ingestion</b>	
Acute Toxicity: No end point data for material.	Minimally Toxic. Based on assessment of the components.
<b>Skin</b>	
Acute Toxicity: No end point data for material.	Minimally Toxic. Based on assessment of the components.
Skin Corrosion/Irritation: No end point data for material.	May dry the skin leading to discomfort and dermatitis. Based on assessment of the components.
<b>Eye</b>	
Serious Eye Damage/Irritation: No end point data for material.	May cause mild, short-lasting discomfort to eyes. Based on assessment of the components.
<b>Sensitization</b>	
Respiratory Sensitization: No end point data for material.	Not expected to be a respiratory sensitizer.
Skin Sensitization: No end point data for material.	Not expected to be a skin sensitizer. Based on assessment of the components.
<b>Aspiration:</b> Data available.	May be fatal if swallowed and enters airways. Based on physico-chemical properties of the material.
<b>Germ Cell Mutagenicity:</b> No end point data for material.	Not expected to be a germ cell mutagen. Based on assessment of the components.
<b>Carcinogenicity:</b> No end point data for material.	Not expected to cause cancer. Based on assessment of the components.
<b>Reproductive Toxicity:</b> No end point data for material.	Not expected to be a reproductive toxicant. Based on assessment of the components.
<b>Lactation:</b> No end point data for material.	Not expected to cause harm to breast-fed children.
<b>Specific Target Organ Toxicity (STOT)</b>	
Single Exposure: No end point data for material.	Not expected to cause organ damage from a single exposure.
Repeated Exposure: No end point data for material.	Not expected to cause organ damage from prolonged or repeated exposure. Based on assessment of the components.

#### TOXICITY FOR SUBSTANCES

NAME	ACUTE TOXICITY
2,6-DI-TERT-BUTYL-P-CRESOL	Oral Lethality: LD50 0.89 g/kg (Rat)

#### OTHER INFORMATION

##### For the product itself:

Repeated and/or prolonged exposure may cause irritation to the skin, eyes, or respiratory tract. Small amounts of liquid aspirated into the lungs during ingestion or from vomiting may cause chemical pneumonitis or pulmonary edema.

##### Contains:

Base oil severely refined: Not carcinogenic in animal studies. Representative material passes IP-346, Modified Ames test, and/or other screening tests. Dermal and inhalation studies showed minimal effects; lung non-specific infiltration of immune cells, oil deposition and minimal granuloma formation. Not sensitizing in test animals.

The following ingredients are cited on the lists below: None.

--REGULATORY LISTS SEARCHED--



Product Name: MOBIL AERO HFA  
Revision Date: 01 Oct 2015  
Page 9 of 12

1 = NTP CARC  
2 = NTP SUS

3 = IARC 1  
4 = IARC 2A

5 = IARC 2B  
6 = OSHA CARC

## SECTION 12 ECOLOGICAL INFORMATION

The information given is based on data available for the material, the components of the material, and similar materials.

### ECOTOXICITY

Material -- Not expected to be harmful to aquatic organisms.

### MOBILITY

More volatile component -- Highly volatile, will partition rapidly to air. Not expected to partition to sediment and wastewater solids.

Less volatile component -- Low solubility and floats and is expected to migrate from water to the land. Expected to partition to sediment and wastewater solids.

### PERSISTENCE AND DEGRADABILITY

#### Biodegradation:

Components -- Expected to be inherently biodegradable

### BIOACCUMULATION POTENTIAL

Majority of components -- Has the potential to bioaccumulate, however metabolism or physical properties may reduce the bioconcentration or limit bioavailability.

## SECTION 13 DISPOSAL CONSIDERATIONS

Disposal recommendations based on material as supplied. Disposal must be in accordance with current applicable laws and regulations, and material characteristics at time of disposal.

### DISPOSAL RECOMMENDATIONS

Product is suitable for burning in an enclosed controlled burner for fuel value or disposal by supervised incineration at very high temperatures to prevent formation of undesirable combustion products. Protect the environment. Dispose of used oil at designated sites. Minimize skin contact. Do not mix used oils with solvents, brake fluids or coolants.

### REGULATORY DISPOSAL INFORMATION

RCRA Information: The unused product, in our opinion, is not specifically listed by the EPA as a hazardous waste (40 CFR, Part 261D), nor is it formulated to contain materials which are listed as hazardous wastes. It does not exhibit the hazardous characteristics of ignitability, corrosivity or reactivity and is not formulated with contaminants as determined by the Toxicity Characteristic Leaching Procedure (TCLP). However, used product may be regulated.

**Empty Container Warning** Empty Container Warning (where applicable): Empty containers may contain residue and can be dangerous. Do not attempt to refill or clean containers without proper instructions. Empty drums should be



Product Name: MOBIL AERO HFA  
Revision Date: 01 Oct 2015  
Page 10 of 12

completely drained and safely stored until appropriately reconditioned or disposed. Empty containers should be taken for recycling, recovery, or disposal through suitably qualified or licensed contractor and in accordance with governmental regulations. DO NOT PRESSURISE, CUT, WELD, BRAZE, SOLDER, DRILL, GRIND, OR EXPOSE SUCH CONTAINERS TO HEAT, FLAME, SPARKS, STATIC ELECTRICITY, OR OTHER SOURCES OF IGNITION. THEY MAY EXPLODE AND CAUSE INJURY OR DEATH.

<b>SECTION 14</b>	<b>TRANSPORT INFORMATION</b>
-------------------	------------------------------

**LAND (DOT)**

**Proper Shipping Name:** COMBUSTIBLE LIQUID, N.O.S. (Distillates (Petroleum), Hydrotreated Light)  
**Hazard Class & Division:** COMBUSTIBLE LIQUID  
**ID Number:** NA1993  
**Packing Group:** III  
**ERG Number:** 128  
**Label(s):** NONE  
**Transport Document Name:** NA1993, COMBUSTIBLE LIQUID, N.O.S. (Distillates (Petroleum), Hydrotreated Light), COMBUSTIBLE LIQUID, PG III

Footnote: This material is not regulated under 49 CFR in a container of 119 gallon capacity or less when transported solely by land, as long as the material is not a hazardous waste, a marine pollutant, or specifically listed as a hazardous substance.

**LAND (TDG):** Not Regulated for Land Transport

**SEA (IMDG):** Not Regulated for Sea Transport according to IMDG-Code

**Marine Pollutant:** No

**AIR (IATA):** Not Regulated for Air Transport

<b>SECTION 15</b>	<b>REGULATORY INFORMATION</b>
-------------------	-------------------------------

**OSHA HAZARD COMMUNICATION STANDARD:** This material is considered hazardous in accordance with OSHA HazCom 2012, 29 CFR 1910.1200.

**Listed or exempt from listing/notification on the following chemical inventories:** AICS, DSL, ENCS, IECSC, KECI, PICCS, TCSI, TSCA

**EPCRA SECTION 302:** This material contains no extremely hazardous substances.

**SARA (311/312) REPORTABLE HAZARD CATEGORIES:** Fire. Immediate Health. Delayed Health.

**SARA (313) TOXIC RELEASE INVENTORY:** This material contains no chemicals subject to the supplier notification requirements of the SARA 313 Toxic Release Program.



Product Name: MOBIL AERO HFA  
 Revision Date: 01 Oct 2015  
 Page 11 of 12

The following ingredients are cited on the lists below:

Chemical Name	CAS Number	List Citations
DISTILLATES (PETROLEUM), HYDROTREATED LIGHT	64742-47-8	1, 17, 18
HYDROTREATED LIGHT NAPHTHENIC DISTILLATE (PETROLEUM)	64742-53-6	1, 4, 13, 17, 18
HYDROTREATED MIDDLE DISTILLATE (PETROLEUM)	64742-46-7	1, 4, 17, 18

--REGULATORY LISTS SEARCHED--

1 = ACGIH ALL	6 = TSCA 5a2	11 = CA P65 REPRO	16 = MN RTK
2 = ACGIH A1	7 = TSCA 5e	12 = CA RTK	17 = NJ RTK
3 = ACGIH A2	8 = TSCA 6	13 = IL RTK	18 = PA RTK
4 = OSHA Z	9 = TSCA 12b	14 = LA RTK	19 = RI RTK
5 = TSCA 4	10 = CA P65 CARC	15 = MI 293	

Code key: CARC=Carcinogen; REPRO=Reproductive

SECTION 16	OTHER INFORMATION
------------	-------------------

N/D = Not determined, N/A = Not applicable

**KEY TO THE H-CODES CONTAINED IN SECTION 3 OF THIS DOCUMENT (for information only):**

H227: Combustible liquid; Flammable Liquid, Cat 4  
 H304: May be fatal if swallowed and enters airways; Aspiration, Cat 1  
 H400: Very toxic to aquatic life; Acute Env Tox, Cat 1  
 H410: Very toxic to aquatic life with long lasting effects; Chronic Env Tox, Cat 1

**THIS SAFETY DATA SHEET CONTAINS THE FOLLOWING REVISIONS:**

Revision Changes:

Section 01: Company Mailing Address information was modified.  
 Section 05: Hazardous Combustion Products information was modified.  
 Section 15: List Citations Table information was modified.  
 Section 15: National Chemical Inventory Listing information was modified.  
 Section 14: Marine Pollutant information was modified.  
 Composition: Component Table information was modified.  
 Section 08: Exposure Limits Table information was modified.  
 Section 16: Revision Information - Implementation of GHS requirements phrase. information was deleted.

The information and recommendations contained herein are, to the best of ExxonMobil's knowledge and belief, accurate and reliable as of the date issued. You can contact ExxonMobil to insure that this document is the most current available from ExxonMobil. The information and recommendations are offered for the user's consideration and examination. It is the user's responsibility to satisfy itself that the product is suitable for the intended use. If buyer repackages this product, it is the user's responsibility to insure proper health, safety and other necessary information is included with and/or on the container. Appropriate warnings and safe-handling procedures should be provided to handlers and users. Alteration of this document is strictly prohibited. Except to the extent required by law,



Product Name: MOBIL AERO HFA  
Revision Date: 01 Oct 2015  
Page 12 of 12

---

re-publication or retransmission of this document, in whole or in part, is not permitted. The term, "ExxonMobil" is used for convenience, and may include any one or more of ExxonMobil Chemical Company, Exxon Mobil Corporation, or any affiliates in which they directly or indirectly hold any interest.

---

Internal Use Only

MHC: 2A, 0, 0, 0, 1, 1

PPEC: C

DGN: 2005454XUS (552975)

---

Copyright 2002 Exxon Mobil Corporation, All rights reserved



## **APPENDIX IV**

### **Declaration of Conformity**





## DECLARATION of CONFORMITY

The design, development and manufacture is in accordance with European Community guidelines

MOVABLE HYDRAULIC JACK (TRIPOD) WITHOUT INTEGRAL PUMP  
AND WITH PNEUMATIC POWER SOURCE

02-0527C0140, 02A0527C0140,  
02B-0527C0140, 02C0527C0140

Relevant provisions complied with by the machinery:  
2006/42/EC

Relevant standards complied with by the machinery:  
EN ISO 12100-1

Identification of person empowered to sign on behalf of the Manufacturer:

A handwritten signature in cursive script that reads "Patrick Finch". The signature is written in black ink and is positioned above a horizontal line.

Quality Assurance Representative





## **APPENDIX V**

### **Maintenance Schedule**





## Maintenance Schedule

### Multi-Stage Tripod Jacks

Tronair recommends performing preventative maintenance on all jacks, which should include a 90-day routine inspection and a 12-month load test.

Model Number \_\_\_\_\_ Serial Number \_\_\_\_\_

Maintenance Performed By \_\_\_\_\_ Date \_\_\_\_\_

#### 90-Day Maintenance:

- Check hydraulic system for leaks including the following:
  - Hydraulic lines; hoses and fittings
  - Hand pump; cylinder, fittings and seals
  - Reservoir; welds and fittings
  - Air operated pump (optional equipment); fittings, air side and oil side seals
- Check jack structure for corrosion, bending, cracking and excessive wear including the following:
  - Ball lock pins
  - Mechanical extension
  - Welded joints; tripod legs, cylinder and foot pads
  - Ram retaining rings
  - Ram lock nuts; gouge marks and cracks in threads
  - Jack pads
- Check fluid level with rams fully retracted. See manual or reservoir tag for proper level height
- Extend rams and visually inspect for corrosion, foreign matter, excessive wear and leaks around ram seals. Remove any foreign matter
- Check air operated pump if equipped (reference air operated pump service manual).
- Check paint condition, touch-up areas that are exposed
- Actuate the hand pump and raise the ram to full extension at least once with a minimum weight of 50 lbs applied.  
**Do not** pressurize hydraulic system once fully extended  
**Do not** allow jack to miss-stage when raising the rams to full extension
- Extend rams and visually inspect for corrosion, foreign matter, excessive wear and leaks around ram seals. Remove any foreign matter
- Apply DoAll, RPM, LPS or equivalent water repellant that is Buna N compatible to the rams
- Open release valve and verify that rams fully retract
- Lubricate casters (if applicable)

#### Annual (12-Month) Maintenance:

- Check hydraulic fluid for contamination (dirt/water) drain and flush if required
- Perform 90-day maintenance checklist
- Capacity test (105% - 110% of jack's rated capacity)

**NOTE:** The jack may be returned to Tronair for load testing, or sent to a local hydraulic repair shop. Please contact Tronair to obtain a "Return Material Authorization Number" (RMA #) before sending any product to Tronair.

the Tronair group of companies:

[www.tronair.com](http://www.tronair.com) | [www.columbusjack.com](http://www.columbusjack.com) | [www.daeind.com](http://www.daeind.com) | [www.datcomedia.com](http://www.datcomedia.com) | [www.eagletugs.com](http://www.eagletugs.com) | [www.malabar.com](http://www.malabar.com)