



# OPERATION & SERVICE MANUAL



**Models: eJP-12  
eJP-12SP  
Electric Towbarless Tug**



04/2024 – Rev. 05

**For Spare Parts, Operations & Service Manuals or Service Needs  
Scan the QR code or visit [Tronair.com/aftermarket](http://Tronair.com/aftermarket)**



The Tronair Group of Companies: Tronair | DatcoMedia | Columbus Jack | Eagle | DAE | Malabar International

**Tronair, Inc.**  
1 Air Cargo Pkwy East  
Swanton, OH 43558

Phone: (419) 866-6301 | 800-426-6301  
Web: [www.tronair.com](http://www.tronair.com)  
Email: [sales@tronair.com](mailto:sales@tronair.com)

REVISION	DATE	TEXT AFFECTED
01	02/2018	Original Release
02	10/2019	Modified Parts List
03	05/2020	Modified Parts List
04	11/2021	Major revision
05	04/2024	Modified 10.2 Recommended Spare Parts Lists

**TABLE OF CONTENTS**

	<b><u>PAGE</u></b>
<b>1.0 PRODUCT INFORMATION.....</b>	<b>1</b>
1.1 DESCRIPTION.....	1
1.2 MODEL & SERIAL NUMBER.....	1
1.3 MANUFACTURER.....	1
<b>2.0 SPECIFICATIONS.....</b>	<b>1</b>
2.1 DIMENSIONS.....	1
2.2 DRIVE SYSTEM.....	1
2.3 STEERING SYSTEM.....	1
2.4 BRAKE SYSTEM.....	1
2.5 OPTIONAL EQUIPMENT AVAILABLE.....	1
2.6 STANDARD EQUIPMENT.....	2
2.7 ADD ON KITS.....	2
<b>3.0 SAFETY INFORMATION.....</b>	<b>3</b>
3.1 USAGE AND SAFETY INFORMATION.....	3
3.2 SAFETY SWITCHES.....	3
3.3 DRIVING SAFETY.....	3
3.4 BATTERY SAFETY.....	3
3.5 MOVING DISABLED TUG.....	4
3.5.1 Disconnect Winch.....	4
3.5.2 Lower Cradle.....	4
3.5.3 Brakes and Steering on Disabled Tug.....	4
<b>4.0 TRAINING.....</b>	<b>4</b>
4.1 TRAINING REQUIREMENTS.....	4
4.2 OPERATOR TRAINING.....	4
<b>5.0 OPERATING INSTRUCTIONS.....</b>	<b>5</b>
5.1 GENERAL INSTRUCTIONS.....	5
5.2 LOADING AIRCRAFT.....	6
5.3 OVER-STEER PROTECTION.....	6
5.4 LOADING AIRCRAFT PROCEDURE.....	6
5.4.1 Normal Loading.....	6
5.4.2 Alternative Loading (Pulling the Cradle Under the Aircraft).....	7
5.4.3 Using The Nose Gear Offset Plate.....	7
5.4.4 Safety Ratchet Strap.....	8
5.5 PREPARING TO MOVE THE AIRCRAFT.....	8
5.6 MOVING THE AIRCRAFT.....	8
5.7 UNLOADING THE AIRCRAFT.....	8
<b>6.0 QUICK NOTES ON BATTERY CARE.....</b>	<b>9</b>
6.1 SAFETY.....	9
6.2 WATERING.....	9
6.3 CHARGING.....	9
6.4 PRECAUTIONS.....	9
<b>7.0 UNDERSTANDING SYSTEM FUNCTIONS FOR TROUBLE SHOOTING.....</b>	<b>10</b>
7.1 EJP-12 DRIVE TRAIN SYSTEM.....	10
7.2 OVER-LOAD SYSTEM.....	10
7.3 BRAKE DESCRIPTION.....	10
7.4 OVER-STEER/ OVER-TORQUE PROTECTION SYSTEM FUNCTION.....	10
7.5 HYDRAULIC SYSTEM.....	10
7.6 RELAY FUNCTION and CONTACTOR FUNCTION (ELECTRICAL TROUBLE SHOOTING).....	11
7.7 PRELIMINARY TROUBLE SHOOTING.....	11
7.8 DASH DISPLAY.....	12
7.8.1 Main Run Page.....	12
7.8.2 Error Messages.....	13
7.8.3 Diagnostic Screens.....	14
<b>8.0 MAINTENANCE.....</b>	<b>16</b>
8.1 GENERAL MAINTENANCE.....	16
8.2 LUBRICATION.....	16
8.3 NYLON STRAPS.....	17
8.4 COMPONENT WEAR.....	17
8.5 REPAIRS.....	17
<b>9.0 PRE-SHIFT CHECKLIST.....</b>	<b>18</b>
<b>10.0 PROVISION OF SPARES.....</b>	<b>19</b>
10.1 SOURCE OF SPARE PARTS.....	19
10.2 RECOMMENDED SPARE PARTS LISTS.....	19
<b>11.0 IN SERVICE SUPPORT.....</b>	<b>19</b>
<b>12.0 GUARANTEES/LIMITATION OF LIABILITY.....</b>	<b>19</b>
<b>13.0 APPENDICES.....</b>	<b>19</b>

This product can not be modified without the written approval of Tronair, Inc. Any modifications done without written approval voids all warranties and releases Tronair, Inc., its suppliers, distributors, employees, or financial institutions from any liability from consequences that may occur. Only Tronair OEM replacement parts shall be used.

**1.0 PRODUCT INFORMATION**

**1.1 DESCRIPTION**

Electric towbarless tug with towing capacity up to 125,000 lbs

**1.2 MODEL & SERIAL NUMBER**

Reference nameplate on unit

**1.3 MANUFACTURER**

**TRONAIR**, Inc.  
1 Air Cargo Pkwy East  
Swanton, Ohio 43558 USA

Telephone: (419) 866-6301 or 800-426-6301  
Fax: (419) 867-0634  
E-mail: sales@tronair.com  
Website: www.tronair.com

**2.0 SPECIFICATIONS**

**2.1 DIMENSIONS**

Weight .....9,500 lbs (4,309 kg)  
Length .....220 in (558.8 cm)  
Height.....42 in (106.7 cm) maximum  
Width.....79 in (200.7 cm)  
Ground Clearance.....5 in (12.7 cm) between drive tires  
Deck Height.....24 1/4 (61.6 cm)  
Cradle Depth .....28 1/2 in (72.4 cm)  
Cradle Width .....38 in (96.52 cm)  
Cradle Lift Height .....12 in at front edge (30.5 cm)  
Cradle Capacity.....12,500 lbs (5,670 kg)  
Steering Axle Tire Size.....(2) 8 x 7-88" (18" OD)  
Drive Tire Size.....(2) 22 x 9 x 16 (22" OD)

**2.2 DRIVE SYSTEM**

Traction Motor .....Two 16HP A.C. electric motors  
Motor Controller .....Two 72 Volt motor controllers  
Gear Reduction .....Two 37.5:1 heavy duty gear reduction torque hubs  
Empty Speed.....7 mph (11 kph)  
Full Load Speed.....4 mph (6.4 kph)  
Throttle type .....Hall-Effect foot throttle  
Battery Type.....Lead Acid (36-D55-17)  
Battery Capacity.....440 Ah (6 HR)  
Charge Time .....Dependent on Charger Selection

**2.3 STEERING SYSTEM**

Dual Drive .....Proportional Steering using Curtis Dual Drive Operation  
Power steering .....Utilizes steering valve and rotary actuator to provide 5th wheel type steering with leaf spring suspension. Steers 87° in each direction

**2.4 BRAKE SYSTEM**

Regenerative .....Soft electric programmed regenerative braking is provided as the accelerator pedal is released.  
Foot Brake.....The brake pedal provides stronger electric regenerative braking.  
Parking Brake.....The parking brake consists of two multiple disc, enclosed type brakes. Maximum holding torque on the parking brake is 2400 in-lbs per side at the motors. Pressing the throttle releases the parking brake.

**2.5 OPTIONAL EQUIPMENT AVAILABLE**

Custom Colors and Graphics  
Fully Automatic Battery Charger (External)  
Type .....Eco Charge  
Rating.....100 Amp at 72VDC

**2.6 STANDARD EQUIPMENT**

- Operator Panel Display with Battery Charge Indicator, Hourmeter, Speedometer, Steering Position Indicator, Diagnostic Functions
- Power Winch (Hydraulic Ram) with Reduced Force on Contact
- Front and Rear Facing LED Headlights
- LED Cradle Work Light
- Strobe Light
- Side Marker Lights
- Fire Extinguisher
- Two Nylon Strut Straps, 1.5" x 36"
- Nylon Winch Strap
- Nylon Safety Strap
- Rear Pintle Hitch

**2.7 ADD ON KITS**

K-4052..... Westwind Adapter	K-5388 .....Falcon 50/900/2000 Adapter (Required)
K-4177..... Sabreliner Adapter	K-5389 .....Falcon 7X/8X Adapter
K-4235..... Dash 8 400	K-5391 .....Lear 45 Cradle Plates (Hold Down)
K-4236..... Dash 8 100, 200, 300	Z-9292.....Dash 8 Stand-Off Plate
K-5387..... Lear 40/45 Adapter (Required)	

### 3.0 SAFETY INFORMATION

#### 3.1 USAGE AND SAFETY INFORMATION

To insure safe operations please read the following statements and understand their meaning. Also refer to your equipment manufacturer's manual for other important safety information. This manual contains safety precautions which are explained below. Please read carefully.



**WARNING!** — Warning is used to indicate the presence of a hazard that **can cause severe personal injury, death, or substantial property damage** if the warning notice is ignored.

**CAUTION!** — Caution is used to indicate the presence of a hazard that **will or can cause minor personal injury or property damage** if the caution notice is ignored.

#### 3.2 SAFETY SWITCHES

1. The Emergency-Stop switch (ES1 or ES2) shuts off the main vehicle contactor and cuts all power from the battery. **WARNING! Do not press the Emergency-Stop switch while in motion unless an emergency truly exists. The Emergency-Stop switch will turn off all electric braking systems and rely on the parking brake to stop the vehicle.**
2. The Seat Switch (SW3) controls the controller input that limits the eJP-12 to creep speed. If the seat switch is not pressed, the eJP-12 will be limited to the programmed creep speed.
3. The solid state switch in the top of the accelerator pedal controls the Interlock (deadman) switch. The same switch also controls the release of the parking brake.
4. The "Start" function of the Key Switch (KS1) turns on relays K1, K2, and K3 to start the eJP-12. If the Key Switch is turned 'OFF' while in motion, the effect will be the same as pressing the Emergency-Stop. **WARNING! Do not turn the Key Switch to OFF while in motion. The Key Switch will turn off all electric braking systems and rely on the parking brake to stop the vehicle.**

#### 3.3 DRIVING SAFETY

1. EJP-12, like any piece of machinery, should be operated by responsible personnel who are alert, attentive and aware of the potential for serious injury or death. Operators should not be under the influence of intoxicants, drugs or any substance that would alter or impair their actions or ability to make responsible and prudent judgments. No person should be allowed to operate the eJP-12 without reading and understanding this operator manual.
2. Operators are expected to know and observe all normal safety procedures for working around aircraft. The operator's knowledge of these general aviation safety procedures is a basic assumption for this manual. The omission of general aircraft safety procedures from the eJP-12 Operator's Manual is no excuse for the operator's failure to apply them.
3. Proper attire should be worn while operating eJP-12. Loose fitting clothing should be avoided. Appropriate outdoor work shoes should be worn at all times.
4. Do not leave the eJP-12 until the parking brake is set.
5. Do not leave the eJP-12 unattended when children are present.
6. The eJP-12 is normally stopped by slowly releasing the accelerator pedal. When stopping on an incline, release the accelerator pedal slowly to reduce roll-back. Use the foot brake if a stronger stop is needed. The parking brake will set when the eJP-12 comes to a complete stop and the accelerator pedal is not pressed.
7. For the smoothest transition while towing an aircraft, the tug should be brought to a stop before changing direction on the F-N-R switch.
8. Always accelerate and brake as smoothly as possible to prevent possible aircraft damage.
9. For moving aircraft up or down inclines/slopes, a qualified operator should be in the aircraft cockpit to utilize the aircraft's brakes for safety/backup.
10. When moving in reverse direction, look both ways and clear the area of other traffic and obstacles.



#### **WARNING**

**Do not allow anyone to sit or ride on the diamond plate or front fenders of the eJP-12 while in motion.**

#### 3.4 BATTERY SAFETY

1. The diamond plate over the batteries should always be open when charging the batteries indoors. During the charging cycle, explosive hydrogen gas is expelled. Open flame or sparks must be avoided. Do not smoke near the batteries while charging.
2. **Important!** All switches need to be turned off before plugging in the eJP-12 for charging.
3. Eye protection and rubber gloves should be worn when adding water or working with the batteries. Remember that the current capability of the batteries is extremely high.
4. Read Appendix III and Appendix IV understand safety procedures for working around batteries.

### 3.5 MOVING DISABLED TUG

#### 3.5.1 Disconnect Winch

1. Chock the main landing gear of the aircraft involved.
2. Carefully lift the battery cover on the driver's side of the eJP-12.



#### CAUTION

The cover is equipped with gas springs. Do not allow the batter cover to hit the aircraft.

3. In the center of the tug, locate the valve with the red knurled button winch cylinder. Press the knurled button and turn it counter-clockwise until it stops and pops out.
4. The winch strap can now be pulled loose enough to disconnect the strut strap from the aircraft.

#### 3.5.2 Lower Cradle

A ¼ inch hex key wrench will be required

1. Find the needle valve (NV1) located on the top of the valve block. The valve is referenced by the label Emergency Cradle Lowering Valve.
2. Open the needle valve very slightly (counter clockwise) to allow the cradle to lower. Tighten the valve (clockwise) to stop the cradle. It is best if the cradle can be stopped with the front edge still approximately ½ to ¾ inch off the ground.

#### 3.5.3 Brakes and Steering on Disabled Tug

1. The eJP-12 is equipped with a mechanical parking brake that is set when there is no hydraulic power. If the eJP-12 needs to be towed, the torque hubs must be unlocked. Unlocking the hubs allows the drive wheels to turn without turning the brake or motor. To unlock, use a 7/16 wrench or socket and remove the two bolts from the round disc in the center of the hub. Flip the disc over and re-install so that the button presses on the center pin. To re-engage hubs put the center disc back to its original position.
2. If the hydraulic pump does not run, the tug can still be maneuvered with the steering wheel. Move the steering wheel slowly (it will be hard to turn) as the tug is rolling.

#### WARNING



When the torque hubs are unlocked, the eJP-12 does not have brakes. Move the eJP-12 slowly. Wheel chocks must be used for stopping.

### 4.0 TRAINING

#### 4.1 TRAINING REQUIREMENTS

The employer of the operator is responsible for providing a training program sufficient for the safe operation of the unit.

#### 4.2 OPERATOR TRAINING

The operator training should provide the required training for safe operation of the unit.

**NOTE: Maintenance and Trouble Shooting are to be performed by a skilled and trained technician.**

TO DISCONNECT WINCH FROM AIRCRAFT IN THE EVENT OF ELECTRICAL FAILURE:

PRESS THE KNURLED RED BUTTON AND TURN IT COUNTERCLOCKWISE UNTIL IT STOPS AND POPS OUT.

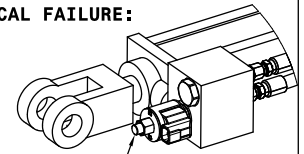

RED BUTTON

PULL THE WINCH STRAP LOOSE ENOUGH TO DISCONNECT THE STRUT STRAP. PRESS THE KNURLED BUTTON AND RETURN TO ORIGINAL POSITION (CLOCKWISE UNTIL IT STOPS).

V-2651

at the rod end of the

NEEDLE VALVE

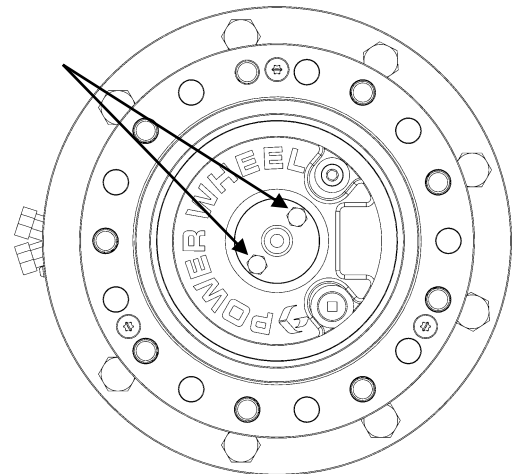
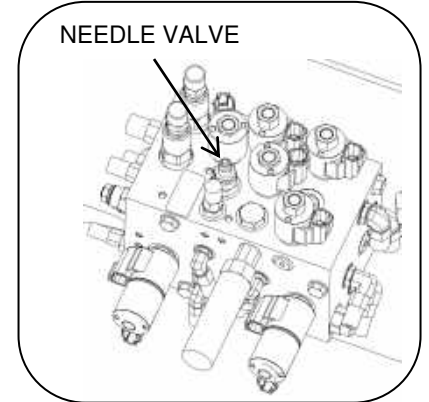

**5.0 OPERATING INSTRUCTIONS****WARNING**

**Do not make sharp turns while moving rapidly. Always look behind you before backing up.**

**5.1 GENERAL INSTRUCTIONS**

1. To start the eJP-12, the Emergency-Stop (E-Stop) switch on the driver's console must be in the released position and the E-Stop switch on the left front fender must be in the released position. To release E-stops, turn clockwise and release.
2. Sit down in the operator's seat. Turn the Forward/Neutral/ Reverse (F/N/R) switch to Neutral.
3. Turn the "Off- On-Start" switch to "Start" and hold for one second. The Operator display screen will come on at this time.
4. The hydraulic pump will start when:
  - a. The F/N/R switch is moved out of Neutral
  - b. Or the Cradle or Winch functions are used
5. Make sure the cradle is off the ground before moving. This is accomplished by pressing the "UP" side of the cradle toggle switch.
6. This tug is NOT designed to coast. Accelerating, braking, and maintaining a constant speed, are all very dependent on foot pedal position. This results in a tug that is very easy to drive and extremely easy to control on inclines. Push the throttle pedal to accelerate, slowly release the throttle to brake. Hold the throttle steady for a steady speed.
7. The switch located under the driver's seat must make contact before the eJP-12 will drive at "sitting speeds". If the driver is in the standing position, the eJP-12 will be limited to "Creep Speed" (approximately 1 mph). All towing positions on the Aircraft Selection switch are limited to 4 mph (6.4 kph). The return to Gate position is limited to 7 mph (11 kph)
8. If the eJP-12 is to be left On when the driver exits the driving position place the F/N/R switch in Neutral. This will prevent the hydraulic system from cycling on and off (charging the accumulator) while the tug is not in motion.
9. The parking brake will set automatically when the eJP-12 comes to a complete stop. The parking brake will also set when the key is turned off or when either Emergency-Stop switch is pressed. (Either of the latter two actions will cause the hydraulic accumulator to discharge.)

**WARNING**

**Turning the "Off-ON-Start" switch to "Off" while driving will result in a complete loss of electric braking and stopping will rely on the parking brake. Pressing either Emergency-Stop switch while driving will result in a complete loss of electric braking and stopping will rely on the parking brake.**

10. The eJP-12 steers very easily. Turning the steering wheel 3-1/4 turns from center will result in turning the steering tires approximately 87°. During a sharp turn, the inside motor will slow to a stop then reverse direction. The eJP-12 is designed to be very maneuverable at slow speeds in tight places, NEVER enter into a turn at high speed. Loss of control will cause personal injury and property damage. Do not move your eJP-12 any faster than is necessary.
11. The steering console can be fully raised to allow the driver to stand while positioning the eJP-12 at the aircraft nose wheel. While the driver is in the standing position, the eJP-12 will be limited to "Creep Speed". This provides better throttle control for capture. While standing, do not apply any sudden throttle or brake that may cause loss of balance. Never drive while standing except for very slow final positioning. Do not allow anyone in the passenger compartment to stand while the tug is in motion. The steering console is raised by pulling the lever on the left hand side of the console and lifting upward.

**WARNING**

**The standing position on the eJP-12 is intended for approaching the aircraft for capture only. Release the aircraft from the sitting position.**

**WARNING**

**Do not make sharp turns while moving rapidly. Always look behind you before backing up.**

**WARNING**

**When moving tug under or out from under the nose of a Gulfstream, Global, or other aircraft with a slanted strut, make sure the winch strap is loosened before swinging. Angle of nose strut can cause winch strap to over tighten causing damage to the nose gear.**

## 5.2 LOADING AIRCRAFT

1. On the driver's control panel, choose between Over Steer Protection (OSP) On or Off. Choosing OSP On adds over-steer protection (some restrictions will apply; refer to section 5.3 Over-steer Protection and 5.4.2 Using The Nose Gear Offset Plate). The OSP Off selection bypasses the over-steer protection.
2. Choose the Max Push/Pull force that best matches the aircraft manufactures limits.
3. Make sure the aircraft nose wheel steering system, hydraulic system, and/or mechanical linkages are either bypassed or disconnected so the wheel is free to turn within the aircraft's prescribed limits. Always check with the aircraft operator to determine the acceptable methods for moving their aircraft.
4. Insure that the winch and strut strap are not twisted or positioned in such a way that it may damage any part of the aircraft assembly to which it is attached for winching or towing.
5. Make sure the strap is narrow enough and positioned properly so it does not interfere with sensors, lines, cams, linkages or other fittings on the aircraft wheel strut. Use of the 1.5 inch-wide strap is recommended. Heavier straps can be requested.



### WARNING

**Do not install the strut strap around the wheel strut so that it could damage any part of the wheel assembly, tires, hydraulic lines, up-locks or sensors during winching or towing operation.**



### CAUTION

**Do not contact the shiny oleo surface with any metal strap components.**



### WARNING

**Some aircraft are authorized by their manufacturers to be moved by towbarless tugs using only approved adapters in lieu of the nylon strut strap. Verify with the aircraft operator the approved method for towing a particular aircraft.**

## 5.3 OVER-STEER PROTECTION

The over-steer protection system is for dual nose wheel aircraft. When pulling the aircraft onto the cradle, both tires should make contact with the mat switch. The operation is simple; when the amount of torque applied to the NLG is sufficient to cause one tire to pull away from the mat switch, the winch will release to relieve the torque. If both wheels leave the mat switch, the winch will hold tight. For the best protection, the cradle needs to remain low with the front edge approximately 3 inches off the ground. Also, there needs to be space in the cradle for the wheels to pivot if an over-steer event takes place. For over-steer protection, leave the side plates spread as wide as possible or remove them. On larger diameter tires, the rear safety gate will also limit the degree of over-steer protection. If the wheels are allowed to firmly contact the rear safety gate and the cradle mat at the same time, the NLG will no longer be protected by the over-steer system. The addition of the cradle safety strap will not cause sufficient force to adversely affect the over-steer protection.

## 5.4 LOADING AIRCRAFT PROCEDURE

### 5.4.1 Normal Loading

Position the eJP-12 in front of the aircraft nose wheel then lower the lift cradle to the ground. Attach the strut strap (or appropriate towing adapter) to the aircraft nose strut in such a way as to not damage the strut, switches or other components that may be part of the nose landing gear. Center the protective sleeve of the strut strap to insure only the sleeve is in contact with the aircraft. Using the winch controls mounted on the left front fender, extend the winch strap out far enough so it can be attached to the strut strap. Make sure the chocks have been removed and the aircraft brakes are not set. Using the front controls so you can monitor the aircraft nose gear, winch the aircraft onto the lift cradle until the nose wheel touches the cradle mat located on the front wall of the cradle. For dual nose wheels, both tires should touch the cradle mat. When the tire touches the cradle mat, a relief valve will reduce the pulling strength of the winch system to 400 lbs. This is to help prevent any inadvertent excess stress on the nose gear. Use the "Cradle Up" button to raise the front edge of the cradle approximately 3 inches off the ground. Re-tighten the winch strap after lifting the cradle.



## 5.4.2 Alternative Loading (Pulling the Cradle Under the Aircraft)

There are times when it is not desirable to allow forward movement of the aircraft while loading. This is especially true in tight hangar conditions. For these situations, the eJP-12 cradle can be pulled under the aircraft.

Set the Forward/ Neutral/ Reverse switch to Forward (this is necessary for eJP-12 parking brake release). The green LED lamp on the fender panel will indicate that the parking brakes have sufficient hydraulic pressure for brake release. Note: if the green light does not come on, check the position of the Forward/ Neutral/ Reverse switch.

Position the eJP-12 in front of the aircraft and connect to the aircraft as in "Normal Loading". Leave the main gear wheel chocks in place and/or aircraft brakes set. Lift the cradle approximately ½ inch off the ground or floor. Use the Winch In command at the front fender while pressing the Brake Release button. When the NLG tires reach the back of the cradle, raise the cradle to 3 inches above the ground and re-tighten the winch strap as in "Normal Loading".

## 5.4.3 Using The Nose Gear Offset Plate

Aircraft having forward facing torque links or gear doors (like Jetstream, Gulfstream G200, Westwind, MU2) will require you to use the offset plate (B) to keep the torque links or gear doors from contacting the cradle front wall. The default position for this plate is the closest slot (G) to the cradle wall. Set the movable side plates (A) to the proper width so the offset plate can slide into place. The offset plate has two possible positions for the moveable side plates. The inner two slots in the offset plate are for single nose wheel aircraft and the two slots closest to the outside of the offset plate are for dual nose wheel aircraft.



**NOTE: When using the offset plate for a dual nose wheel aircraft, over-steer protection is limited to the wheel movement between:**

- **The side plates. If the wheels are allowed to contact the side plates, the NLG will no longer be protected by the over-steer system.**
- **The offset plate and the rear safety gate. If the wheels are allowed to firmly contact the rear safety gate and the offset plate at the same time, the NLG will no longer be protected by the over-steer system.**

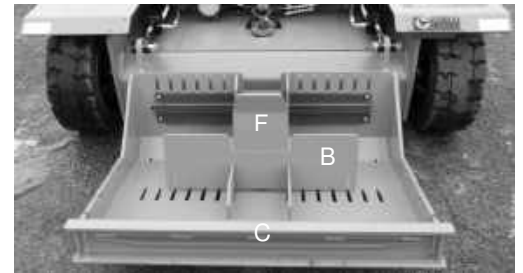

Some aircraft are required to use adapters in order to be towed by towbarless tugs (like Falcon 50, Lear 45). Under these circumstances the offset plate should be used to allow the aircraft to be loaded safely without the towbar head contacting the forward wall of the cradle. If a single nose wheel aircraft were being loaded using an adapter it would be easiest to not have the single nose wheel adapter (F) in place on the offset plate yet. Pull the aircraft in with the winch first until the nose wheel is in close proximity to the offset plate. Then slide the single nose wheel adapter (F) into its receiver and make sure it is locked in place by the spring plunger. Then snug up the nose wheel to the offset plate with the winch.

Depending on the size of the towbar head adapter, it may be necessary to use the second offset plate slot (G) to provide enough space for the adapter to fit in front of the cradle wall.

- |                           |                              |
|---------------------------|------------------------------|
| A. Movable Side Arms      | E. Safety Strap Holes        |
| B. Nose Gear Offset Plate | F. Single Nose Wheel Adapter |
| C. Rear Safety Gate       | G. Offset Plate Slots        |
| D. Cradle Mat             |                              |



### WARNING

**When using the offset plate for a dual nose wheel aircraft, over-steer protection is limited to the wheel movement between the side plates. If the wheels are allowed to contact the side plates, the NLG will no longer be protected by the over-steer system.**



### WARNING

**When using the offset plate for a dual nose wheel aircraft, over-steer protection is limited to the wheel movement between the offset plate and the rear safety gate. If the wheels are allowed to firmly contact the rear safety gate and the offset plate at the same time, the NLG will no longer be protected by the over-steer system.**



### WARNING

**Be extra careful when moving aircraft on inclines as aircraft or tug may move unexpectedly. Make sure no personnel are in the direct path of the aircraft or tug.**

#### 5.4.4 Safety Ratchet Strap

Secure the aircraft nose wheel with the safety ratchet strap. Position the strap so as not to damage any aircraft component and tighten with the ratchet to be just snug. The strap attaches through one of the two sets of rings (E) in the cradle side arm and runs across the top of the tire in front of the nose wheel strut and down to the corresponding ring in the other cradle side arm. In most cases it is preferable to run the safety strap over the top of the strut strap.

Drop the rear safety gate into the slots in the cradle side arms.

#### **WARNING**



**Pay close attention to where disconnected scissors rest. With the change in angle of the cradle moving up and down, a nose strut scissor could fall down and become pinched against the rear gate, causing significant damage.**

#### 5.5 PREPARING TO MOVE THE AIRCRAFT

Raise the lift cradle enough to safely clear obstacles on the ground and to provide necessary clearance between the aircraft and top of tug to avoid damage if the oleo strut compresses. For over-steer protection applications, limit the cradle lift to approximately 3 inches measured from the ground to the edge of the cradle. After raising the cradle, the winch strap will loosen due to the rotation of the cradle. Push the "winch in" button and snug up the winch strap prior to moving the aircraft.

#### **WARNING**



**Do not raise the cradle fully unless it is necessary to drop the tail of the aircraft to clear an obstacle. Lifting the nose wheel too high will cause a shift in the aircraft's center of gravity and this could cause the aircraft to tip onto its tail.**

#### 5.6 MOVING THE AIRCRAFT

Move the aircraft slowly by choosing the direction of desired travel and slowly pressing the foot throttle.

#### 5.7 UNLOADING THE AIRCRAFT

1. Loosen the winch strap and lower the lift cradle to a position 1/2" above the ground. Chock the aircraft and remove rear safety gate, strut strap and safety strap.
2. Back the eJP-12 away from aircraft, allowing the nose wheel of aircraft to roll off the lift cradle onto the ground.

**6.0 QUICK NOTES ON BATTERY CARE**

This section provides very general instructions for battery care. The battery in this vehicle represents a large investment and proper care of the battery is vital to the performance of this vehicle. Refer to Appendix III in this manual for the full Crown Battery Service Manual.

**6.1 SAFETY**

1. Always wear eye protection and rubber gloves when working with batteries.
2. Never wear jewelry, watches or rings while working around batteries.
3. When working on eJP-12, always UNPLUG the battery from the tug. The battery pack is capable of extremely high currents and could cause serious damage or injury if short-circuited.
4. If battery acid is accidentally spilled on the skin, immediately flush the area with large amounts of water. **Electrolyte splashed in the eyes is extremely dangerous!** If this should happen, force the eye open and flood it with cool, clean water for approximately fifteen minutes. A doctor should be called immediately when the accident occurs.
5. If you have any doubts or questions, contact Tronair, Inc.
6. The tug charging location should have good ventilation to the outside air. Signs should be posted for “Explosive Gases”, “No Smoking”, “No Sparks”, “No Open Flames”, and “No Electric Motors”. Check for additional local ordinances concerning battery-charging safety.

**6.2 WATERING**

1. Add approved water only to a fully charged battery. If the water in your area is not suitable (due to chemicals and impurities) use distilled or de-ionized water.
2. Keep battery cells filled to proper level. Low water can cause permanent damage to batteries.
3. Check water level once a week. Replace water lost to evaporation. Never add water to a discharged battery. If upon inspection water is below the battery plate separators before charging, add just enough water to cover the separators.
4. Never add sulfuric acid to a battery.
5. Do not transfer acid from one cell to another. Never allow the batteries to stand in an uncharged state. Plate damage will occur.

**6.3 CHARGING**

1. **Keep battery compartment open during charging to ensure proper ventilation.**
2. The batteries should be recharged when the state of charge indicator has declined to 30-40% (all green lights off).
3. Keep flame and metal away from the battery tops to prevent battery gasses from exploding.
4. Cool before charging or operating, if battery is above 115° F.
5. Press the emergency stop switch to shut off all electronics prior to charging. In the event that the emergency stop switch is not pressed, the limit switch at the charging plug will shut the tug off.

**6.4 PRECAUTIONS**

1. Read Appendix III and “Safety Precautions”
2. Keep battery tops clean and dry.
3. Be sure battery caps are on and secure for spark protection.
4. Check specific gravity levels weekly, after charging, but not directly after service watering. Refer to Appendix III.
5. Do not overcharge batteries. Allow several hours use between charges.

**7.0 UNDERSTANDING SYSTEM FUNCTIONS FOR TROUBLE SHOOTING****7.1 EJP-12 DRIVE TRAIN SYSTEM**

The eJP-12 is powered by two 16HP AC motors. The motors are connected directly in-line with the brakes and torque hubs for maximum mechanical efficiency. Motor input to Hub output ratio is 37.5:1. The maximum programmed draw-bar pull is 8750 lbs. (horizontal pulling value).

The motors are driven by two separate motor controllers; each is rated at 650 amps for 1 minute and 195 amps continuous (1 hour). The controllers work in a Master/Slave configuration. Proportional steering is accomplished with Curtis Dual Drive Operation.

The maximum empty driving speed is 7 MPH. Acceleration and deceleration rates are programmed for smooth starts and stops thereby limiting the load applied to the NLG.

**7.2 OVER-LOAD SYSTEM**

The output torque, and thereby drawbar-pull, is controlled by programming maximum amperage limits for a given input. The input signal is provided by a six position selector switch. The present limits are set for draw-bar pulls of 3700 lbs., 5400 lbs., 6400, 7000 lbs., and 8750 lbs. If a situation is encountered that requires higher amperage than the pre-set limit, the EJP-12 will come to a stall. The winch is limited to a value just slightly below the draw-bar pull for each setting. When the winch reaches its maximum pull strength for the chosen input setting, the relief system will begin to cycle.

**7.3 BRAKE DESCRIPTION**

The eJP-12 has electric dynamic braking and two hydraulically opened parking brakes. The dynamic braking system is regenerative electric braking from the motors and is provided in two forms. First, as the operator reduces pressure on the accelerator pedal, either partially or fully, the motors begin braking. This is a soft regenerative braking and typically is sufficient for stopping the aircraft. If additional stopping power is needed, the foot brake can be used to provide stronger regenerative braking. This tug is designed to NOT coast when the accelerator pedal is released. Holding the throttle steady will result in a steady speed. Releasing the throttle will apply programmed regenerative braking.

The parking brakes consists of two "multiple disc type" brakes, one on each drive motor. These are located at the end of each motor. The brakes are spring set and are hydraulically opened when the accelerator pedal is used. When the tug comes to a stop, the parking brakes will set automatically. If stopping on an incline, release the accelerator pedal slowly. This will allow the Hill-Hold feature to take effect and limit roll-back as the parking brakes set.

In some tight hangars it is desired to pull the eJP-12 cradle under the aircraft tires. Some models starting mid 2021 will have a Brake Release button near the Winch In button on the fender panel. The Forward/ Neutral/ Reverse switch must be set to Forward. This allows the hydraulic pump to run and maintain enough pressure for brake release. The green LED on the fender panel indicates that there is sufficient hydraulic pressure for brake release. When the Brake Release button is pressed along with the Winch In button, the winch will pull the eJP-10 forward.

**7.4 OVER-STEER/ OVER-TORQUE PROTECTION SYSTEM FUNCTION**

The over-steer/over-torque protection allows enough travel in the winch strap to relieve the torque on the NLG. Initially there is a small amount of stretch in the winch strap and flex in the tires. When sufficient torque is applied to the NLG to cause one of the tires to pull away from cradle mat, the winch strap will travel outward to relieve the torque. If the second tire pulls away from the cradle mat, the winch strap will lock again. To apply over-steer protection, set the OPS switch to the On position.

**7.5 HYDRAULIC SYSTEM**

The hydraulic system is used for parking brake release, steering, cradle motion, and winch motion. The hydraulic system uses an accumulator to store power for steering and brake release. A pressure switch turns the system on at 1350 PSI and off at 1850 PSI for accumulator charging. The hydraulic pump has an internal 2500 PSI relief valve. See INS-2387 hydraulic schematic.

7.6 RELAY FUNCTION and CONTACTOR FUNCTION (ELECTRICAL TROUBLE SHOOTING)

- In series, the Key On switch and driver's panel Emergency-Stop switches control 72VDC power to the coil of Contactor 1. When energized, Contactor 1 turns on the 72V-24V DC/DC converter.
- 24 V power is available to the Key Switch (KS1) when the converter is ON. Turning the Key Switch to the Start Position (KS2), Turns on Relays K1, K2, and K3.
- K1 is simply the Key Switch memory circuit.
- K2 applies 24VDC to the remainder of the 24V circuit.
- K3 applies power to the 12V lighting circuits.
- K4 turns the pump throttle signal on. On models having the Brake Release button on the fender panel, the pump throttle is controlled by VCL on the CAN bus and the K4 relay is not used.
- K5 is a brake light relay and only used with a Brake Light /Turn signal option.
- K6 is used to close the SV5 brake valve when the eJP-12 is turned on..
- Contactor 2 is the main vehicle contactor and is pulled in when K2 relay closes. This contactor remains energized throughout operation.
- Contactor 3 and 4 are the motor controller contactors and are pulled in by the Master and Slave controllers. Both of these contactors remain energized throughout operation.
- Contactor 5 is turned on by the Pump Motor controller when the Key Switch is turned to start. This contactor remains energized throughout operation.
- All drive speed, current limit, and winch limit functions are programmed into the Curtis 1238 motor controllers.

7.7 PRELIMINARY TROUBLE SHOOTING

TROUBLE	PROBABLE CAUSE	ACTION
Won't Start	Is the E-stop at the driver's panel pressed?	E-stop must be released. Turn clockwise to release
	Is the charger plugged in?	Vehicle must be off charge and have the battery plugged into the vehicle.
	Was the On switch held in the Start position?	May have to hold in Start position 1-2 seconds
	Is the battery dead?	Check battery charge
	Has the battery been unplugged from the vehicle?	Check under the front cover on the driver's side to see that the battery is plugged into the vehicle
	Is the E-stop on the front left fender pressed?	E-stop must be released. Turn clockwise to release
Won't Move	Is the driver sitting in the seat?	Switch in seat must make contact for driving at normal speed or towing at any speed.
Won't Move While Standing	Seat switch must make contact after initial start.	If the vehicle was started with the driver standing, driver must sit to initiate seat switch before continuing.
Slow Speed Only	Is the driver sitting in the seat?	Switch in seat must make contact for driving at normal speed or towing at any speed.
Winch makes cycling noise and fails to move aircraft	Is the Aircraft Selector switch in the correct setting for the aircraft? Are the brakes on the aircraft set?	The winch will only pull as hard as the value selected on the Aircraft Selector switch.

## 7.8 DASH DISPLAY

### 7.8.1 Main Run Page

This screen will be displayed at vehicle start-up.

- Visual Steering Angle indicator will show steering tire position.
- Textual Steering Angle display shows steering tire position in degrees right (R) or left (L)
- Visual Battery State of Charge display is shown. Each bar equals approximately 10% of battery capacity.
- Textual Battery State of Charge shows percentage of remaining charge.
- A LOWBATT indication will flash along with red LED lights when battery state of charge is equal to or below 30% (1 second on, 1 second off).

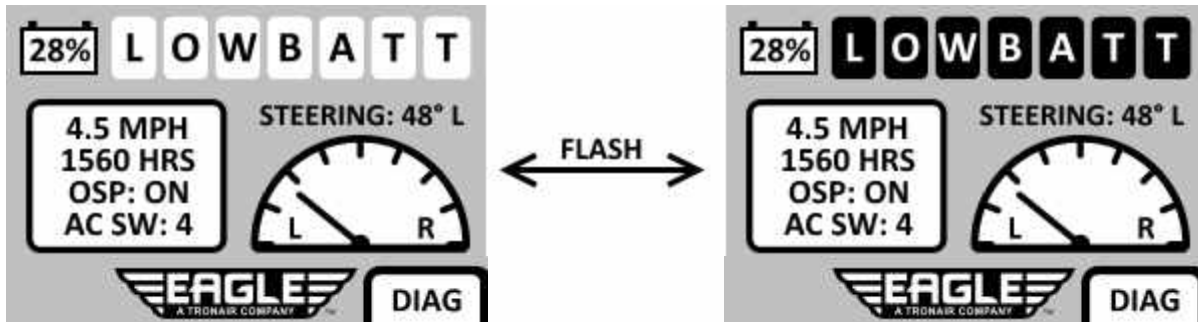

- Speed is shown in MPH. (Based on speed of left hand motor.)
- The Hour Counter is shown below the speedometer.
- Oversteer Protection status, ON or OFF is shown below the Hour Counter.
- Aircraft Switch position is shown as AC SW: (1-6).
- A ((P)) will flash when the Parking Brake is engaged (1 second on, 1 second off).

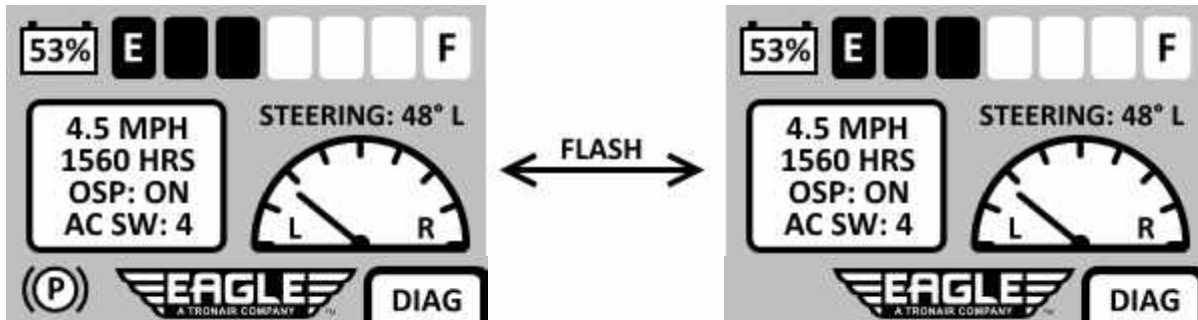

## 7.8.2 Error Messages

- An Over-Steer Fault will cause the red LED's to flash (1 second on / 1 second off) and will show a warning message "OVERSTEER FAULT" similar to below.
- When a Controls Error is active, the red LED's will flash (1 second on, 1 second off) and the warning message "CONTROLS FAULT" will be displayed.



- When Over-Steer Protection is turned OFF, the "OSP: OFF" text will flash (1 second on, 1 second off).

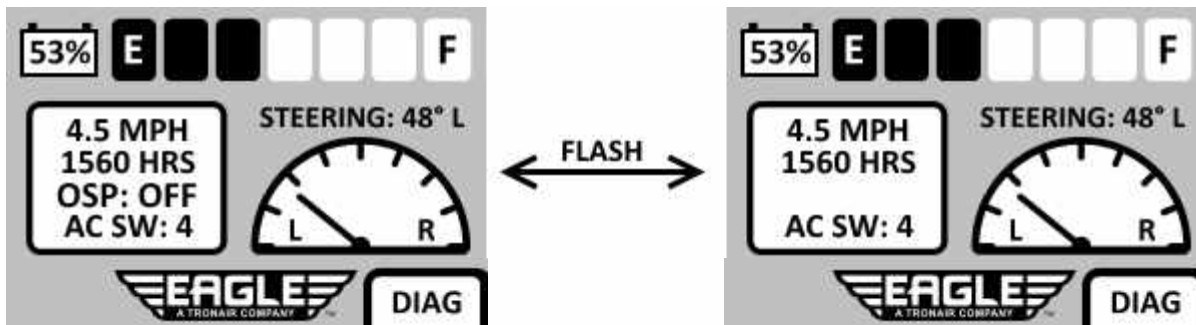

### 7.8.3 Diagnostic Screens

Pressing the “D” button will enter the diagnostic screens. Diagnostics are broken into “pages” for viewing. Arrow buttons will toggle between pages, with “EXIT” returning to the main menu.

#### Curtis Controller Error Display:

The screen displays 2-digit numeric codes from the Master or Slave controller. All active codes in a display loop.



The remaining screens are used for diagnostic and trouble-shooting purposes. The next 5 screens show the On/Off status of inputs and outputs that are programmed into the Master and Slave motor controllers.

#### Winch Functions:

Winch In input (S-J1-11) ON/OFF  
 Winch Out input (S-J1-12) ON/OFF  
 Winch In output (M-J1-4) ON/OFF  
 Winch Out output (M-J1-3) ON/OFF  
 Pump Throttle output (M-J1-20) ON/OFF  
 Cradle Plug input (M-J1-14) ON/OFF

#### Winch Relief Functions:

Winch Relief output (S-J1-3) ON/OFF  
 Oversteer Mat 1 input (S-J1-22) ON/OFF  
 Oversteer Mat 2 input (S-J1-33) ON/OFF  
 Aircraft Selector value input (M-J1-24) 0-10 VDC  
 PS2 input (S-J1-24) 0-10 VDC  
 Timer output (M-J1-19) ON/OFF  
 Oversteer ON input (S-J1-14) ON/OFF

#### Pump Functions:

PS1 input (M-J1-11) ON/OFF  
 Pump Throttle output (M-J1-20) ON/OFF

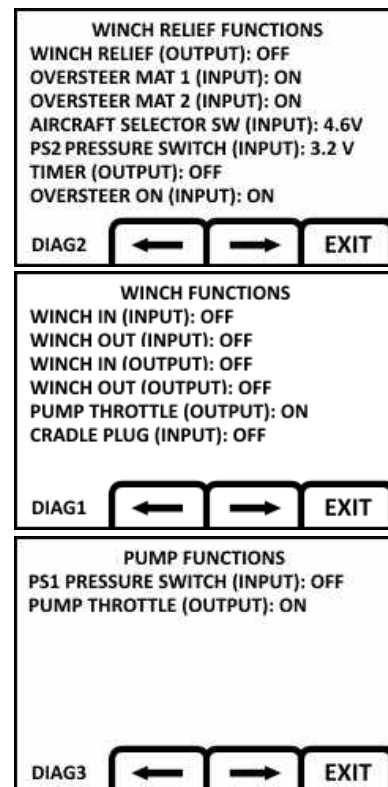

7.8.3 Diagnostic Screens (*continued*)

**Cradle Functions:**

- Cradle UP input from RS1 (S-J1-9)
- Cradle DOWN input from RS2 (S-J1-10)
- Cradle UP output to SV1A (S-J1-2)
- Cradle DOWN output to SV1B (S-J1-4)
- Pump Throttle output (M-J1-20) ON/OFF

**Drive Functions:**

- Seat Switch input (M-J1-10) ON/OFF
- Interlock input (M-J1-9) ON/OFF
- Park Brake release output SV3 (M-J1-5) ON/OFF
- Park Brake release output SV7 (S-J1-5) ON/OFF
- Slave motor contactor output (S-J1-6) ON/OFF
- Master motor contactor output (M-J1-6) ON/OFF

The next 2 screens show information used to trouble-shoot Throttle, Brake, Motor, or heat issues.

**Primary and Secondary Drive Monitor:**

- System Throttle Voltage
- System Brake Voltage
- Battery Voltage
- Steering Sensor Voltage (2 decimal places required)
- Calculated Steering Angle
- RPM (x2)
- Motor RMS Current (x2)
- Motor Throttle Percent (x2)
- Motor Brake Percent (x2)

**Motor and Controller Temperatures:**

- LH Master Motor Temperature
- Master Drive Temperature
- LH Master Motor Temperature
- Master Drive Temperature

**Backlight and Contrast:**

Pressing the "A" button during normal run operation launches the backlight and contrast adjust screen with built-in timeout to return to the main menu.

**Units:**

Pressing the "B" and "C" buttons simultaneously while on the main Run page will switch speed units from MPH to KPH or vice-versa.

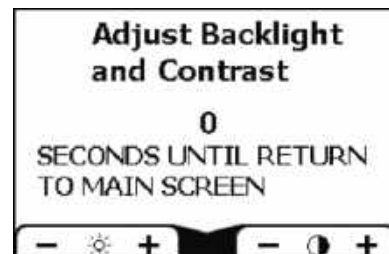
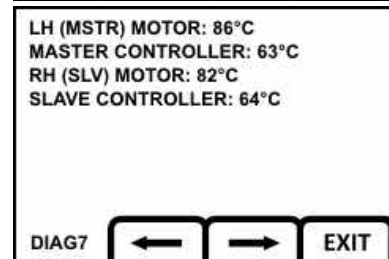
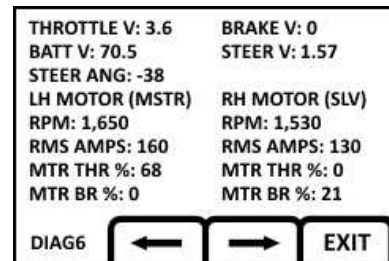
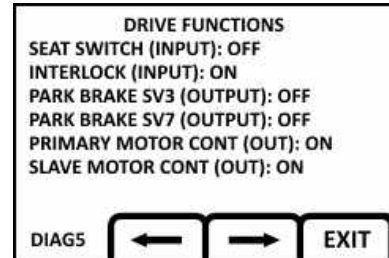
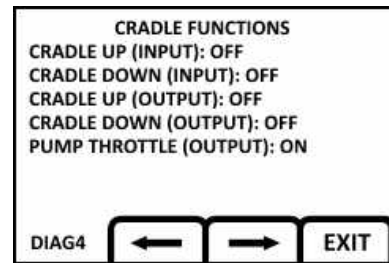

## 8.0 MAINTENANCE



### WARNING

All work on the eJP-12 tug should be performed by competent repair personnel. Before performing maintenance, review all safety procedures.

## 8.1 GENERAL MAINTENANCE



### WARNING

Be certain the eJP-12 is turned off and the battery is unplugged before performing any maintenance. The hydraulic accumulator can hold pressures up to 2500 PSI while the power is turned on. The accumulator will dump system pressure through valve SV4 when the power is turned off. This release of pressurized fluid into the reservoir can be heard every time the eJP-12 is turned off may take as long as 15 seconds.

1. Check battery water level weekly.
2. Periodically check the electrical and battery connections for looseness and tighten if necessary.
3. Check all bolts and hydraulic fittings for looseness. Tighten if necessary.
4. If battery acid should spill into the battery box or on metal parts, flush with water and baking soda. Sprinkle baking soda in bottom of battery box to prevent corrosion.



### WARNING

Battery acid is corrosive. Wear gloves and eye protection when servicing batteries.

5. Keep eJP-12 in a clean condition. Check for any unusual conditions, such as bent metal or broken parts.
6. Electric vehicles, such as eJP-12, should never be steam cleaned.
7. Tire Replacement. Replace worn tires with equal or greater capacity tires only. Do not change tire dimensions when replacing tires.

## 8.2 LUBRICATION

### LUBRICATION CHART

Lube Point	Interval	Lube Spec	Remarks
Hydraulic Pump	Daily	MIL-PRF-5606)	Check level
Torque Hubs	First 50 hrs Semi-Annual or 200hrs	80/90 Wt. Gear lube Oil	Change
Lift Cradle Pivots	Monthly	SAE 50	
Hydraulic Cylinder Pivots	Monthly	SAE 50	Lube both ends
Steering Axle Hubs	Annually	Lithium Bearing Grease	Re-pack bearings



### CAUTION

To avoid potential injury or equipment damage, use proper support and block front tires when either end of tug is raised.

1. Repack both steering axle hubs with wheel bearing grease on an annual basis. Clean bearings and remove all old grease using solvent. Do not mix greases having different bases.
2. Check the oil level in the hydraulic pump reservoir every day during preoperational check. Add hydraulic oil, if necessary. Use MIL-PRF-5606 hydraulic fluid. Make sure the cradle and winch cylinders are fully retracted and power is off prior to adding fluid. Fluid level should be at least one and one half inches down from the top.
3. Torque Hub Lubrication. Rotate torque hub so that the two filler holes in the face of the hub are at the 12 and 3 o'clock positions. Remove the level screw at the 3 o'clock position of the axle. If oil is not at the level of the threads, add SAE 90W at the filler plug on top.

## 8.3 NYLON STRAPS

1. **Pre-shift Inspection Of Straps:** Winch, strut and safety straps should be inspected during the daily pre-shift inspection process.

**WARNING**

**These straps are the primary means of securing the aircraft to the eJP-12. Failure of these components could result in death or serious injury and/or significant damage to the aircraft.**

2. **Worn/Damaged Straps:** Discontinue use of any strap that shows signs of wear or damage such as torn or frayed edges, damaged "D" rings or hooks, loose or broken stitching, signs of chemical damage or holes in webbing of strap.
3. **Periodic Strap Inspection:** Strut and winch straps are degraded in tension capacity by normal wear, age and exposure to the elements. Operators should inspect straps daily during normal pre-shift inspection.
4. **Routine Strap Replacement:** Strut and winch straps should be associated with a specific tug and tracked for age. Straps should be routinely replaced annually or after 150 hours of use, whichever occurs first. Replacement is mandatory if inspection shows any wear or damage that would lower maximum capacity of the straps or fittings.
5. **Non-Routine Strap Replacement:** Appendix VI is provided as a guideline for inspecting straps. **Straps provide the primary securing device for your aircraft and as such should be of primary importance in the maintenance cycle.**

## 8.4 COMPONENT WEAR

Tires should be replaced when the tread depth is less than ¼ in.

## 8.5 REPAIRS

1. Repairs needed on your eJP-12 should be performed by competent repair personnel.
2. The batteries in your eJP-12 must be replaced with like batteries. The charger has been designed to operate with this size battery. Do not substitute a higher or lower Amp/hour rated battery. All batteries should be replaced at the same time.
3. **Do not attempt to repair the electronic controller.** Contact Tronair for proper repair procedures.
4. Contact Tronair before making substitutions of any parts.

**9.0 PRE-SHIFT CHECKLIST**

Perform this check every day prior to the first shift. Place X if ok.  
Do NOT operate any EJP-12 unit until all discrepancies have been corrected

Function	Week Of: _____							
	Date							
Inspected By								
<b>Check Fluid Levels</b>								
Hydraulic Reservoir								
Battery Water Level								
<b>Condition Check</b>								
Hydraulic Hose								
Parking Brake Lines								
Winch Hydraulic Lines								
Lift Cradle Hydraulic Lines								
Nylon Winch Strap								
Nylon Attachment Straps								
Tires								
Lights								
<b>Operational Check</b>								
Foot Service Brake								
Dead Man Switch (in accelerator)								
Regenerative Electric Braking								
Steering								
Winch Cylinder								
Lift Cradle								
Cradle Mat								
<b>Leak Check</b>								
Hydraulic Pump Bay								
All Hydraulic Lines								
Battery Cases								
Torque Hubs								
<b>Monthly Torque Specs</b>								
Drive Wheel Lug Nuts – 128 ft lbs								
Rear Wheel Lug Nuts – 90 ft lbs								

Make copies of this page for continued use.

## 10.0 PROVISION OF SPARES

### 10.1 SOURCE OF SPARE PARTS

Spare parts may be obtained from the manufacturer:

<b>TRONAIR</b> , Inc.	Telephone: (419) 866-6301 or 800-426-6301
1 Air Cargo Pkwy East	Fax: (419) 867-0634
Swanton, Ohio 43558 USA	E-mail: sales@tronair.com
	Website: www.tronair.com



For Spare Parts, Operations & Service Manuals or Service Needs:  
Scan the QR code or visit Tronair.com/aftermarket

### 10.2 RECOMMENDED SPARE PARTS LISTS

Reference the following page(s) for Replacement Parts and Kits available.

- K-4225..... Filter Element Kit
- K-5099..... Battery Watering Kit
- H-3930 ..... Strut Strap
- H-3931 ..... Safety Strap
- H-3933 ..... Protective Cover
- EC-1619-04..... Low Voltage Limiter Fuse
- EC-1619-18..... Low Voltage Limiter Fuse
- NVSP-34-007-CA..... LED Headlight

## 11.0 IN SERVICE SUPPORT

Contact Tronair, Inc. for technical services and information. See Section 1.3 – Manufacturer.

## 12.0 GUARANTEES/LIMITATION OF LIABILITY

Tronair products are warranted to be free of manufacturing or material defects for a period of one year after shipment to the original customer. This is solely limited to the repair or replacement of defective components. This warranty does not cover the following items:

- a) Parts required for normal maintenance
- b) Parts covered by a component manufacturers warranty
- c) Replacement parts have a 90-day warranty from date of shipment

If you have a problem that may require service, contact Tronair immediately. Do not attempt to repair or disassemble a product without first contacting Tronair, any action may affect warranty coverage. When you contact Tronair be prepared to provide the following information:

- a) Product Model Number
- b) Product Serial Number
- c) Description of the problem

If warranty coverage is approved, either replacement parts will be sent or the product will have to be returned to Tronair for repairs. If the product is to be returned, a Return Material Authorization (RMA) number will be issued for reference purposes on any shipping documents. Failure to obtain a RMA in advance of returning an item will result in a service fee. A decision on the extent of warranty coverage on returned products is reserved pending inspection at Tronair. Any shipments to Tronair must be shipped freight prepaid. Freight costs on shipments to customers will be paid by Tronair on any warranty claims only. Any unauthorized modification of the Tronair products or use of the Tronair products in violation of cautions and warnings in any manual (including updates) or safety bulletins published or delivered by Tronair will immediately void any warranty, express or implied.

The obligations of Tronair expressly stated herein are in lieu of all other warranties or conditions expressed or implied. **Any unauthorized modification of the Tronair products or use of the Tronair products in violations of cautions and warnings in any manual (including updates) or safety bulletins published or delivered by Tronair will immediately void any warranty, express or implied and Tronair disclaims any and all liability for injury (WITHOUT LIMITATION and including DEATH), loss or damage arising from or relating to such misuse.**

## 13.0 APPENDICES

- APPENDIX I Wiring Diagram INS-2441
- APPENDIX II Hydraulic Schematic INS-2387
- APPENDIX III Battery Manual
- APPENDIX IV Battery SDS
- APPENDIX V Curtis Diagnostics and Troubleshooting
- APPENDIX VI Battery Charger Operator/Installer Manual
- APPENDIX VII Flat Sling Inspection
- APPENDIX VIII Royco 756 (MIL-PRF-5606) Safety Data Sheet (SDS)
- APPENDIX IX Declaration of Conformity

**Parts List Illustration**

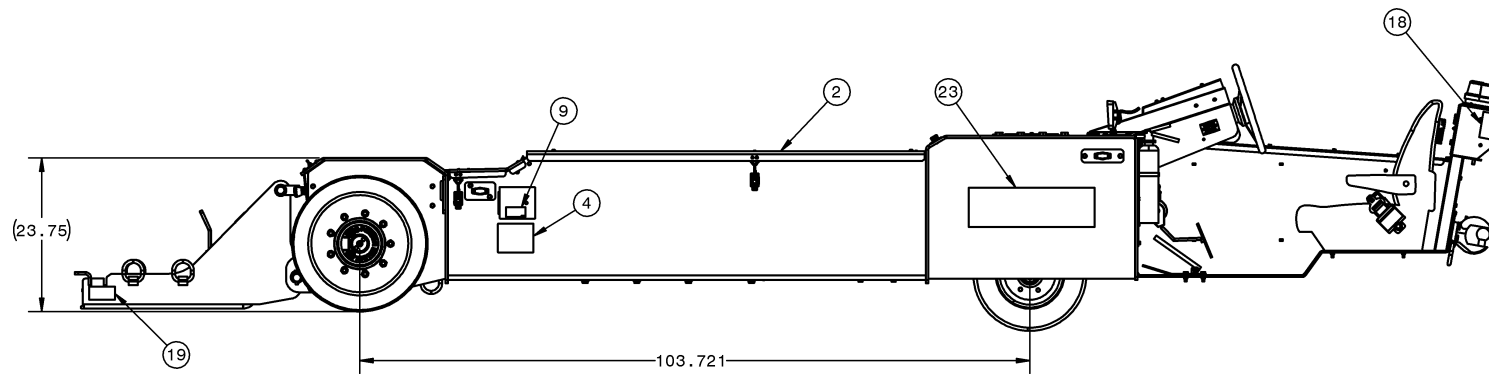
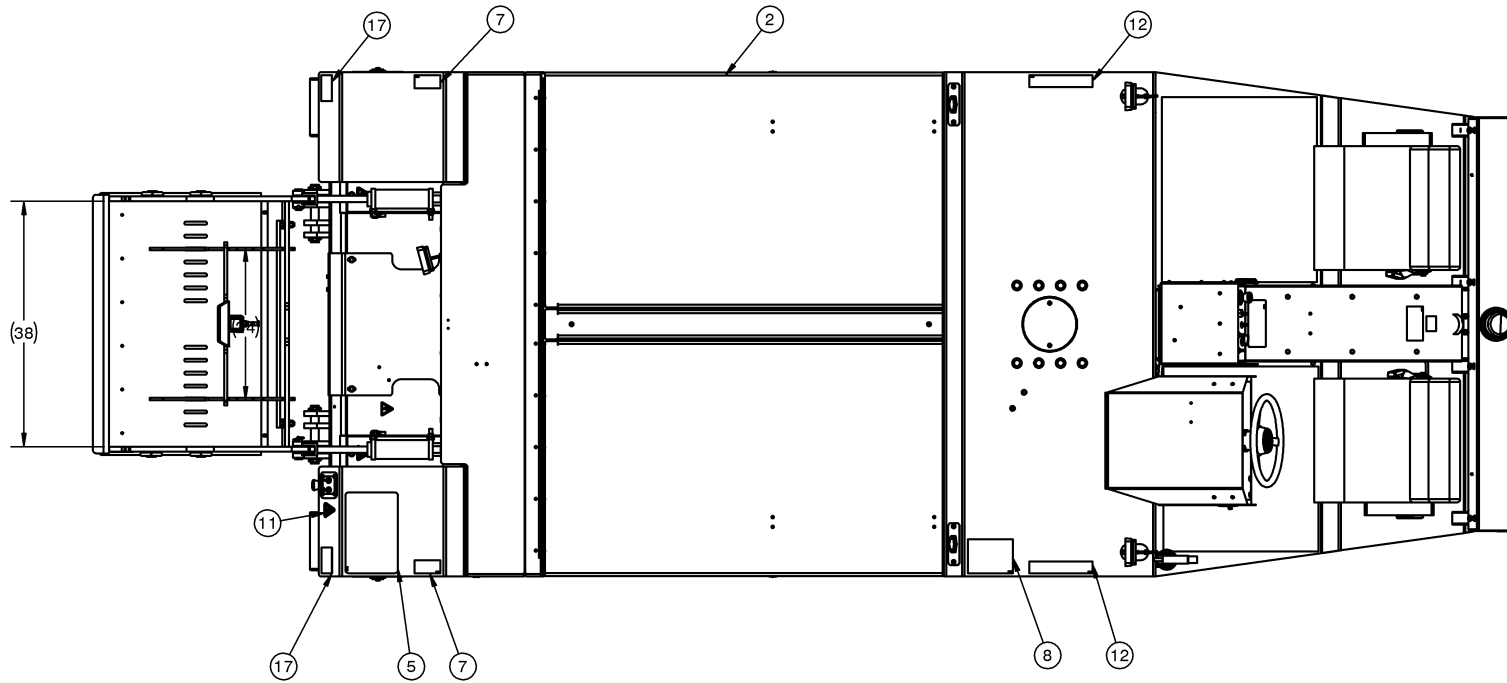

### Parts List

When ordering replacement parts/kits, please specify model, serial number and color of your unit.

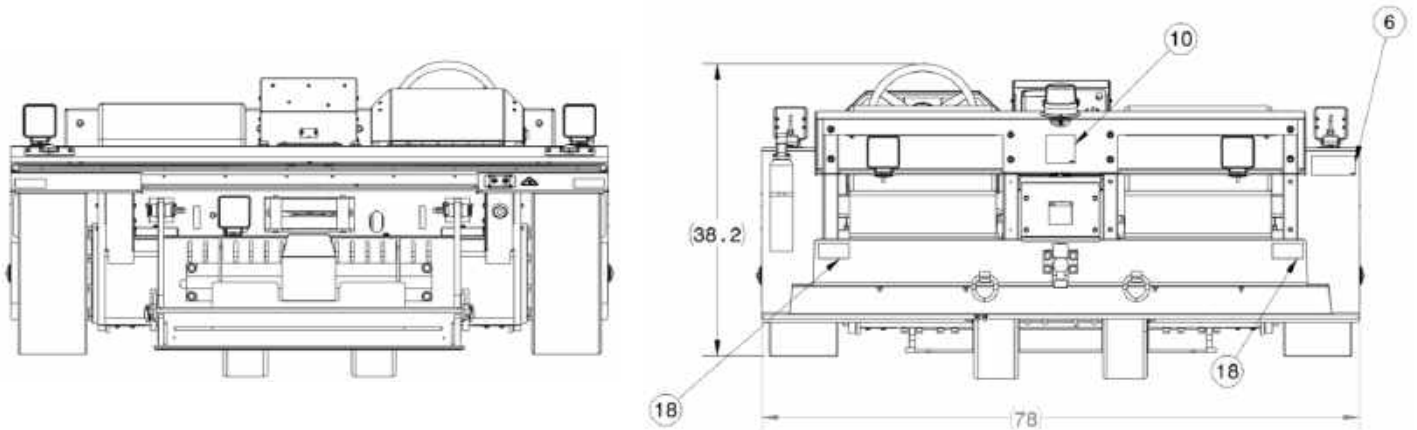

Item	Part Number	Description	Qty
1	Z-9593-01/SP	FRAME PACKAGE	1
2	Z-9506	ASSEMBLY, eJP12	1
3	Z-9026-01/SP	CRADLE PACKAGE	1
4	V-2696	LABEL, CHARGER PLUG	1
5	V-2859	LABEL, LOADING INSTRUCTION	1
6	V-2249	LABEL, FASTEN SEAT BELT	1
7	V-2194	LABEL, SIT DOWN	2
8	V-2187	LABEL, BATTERY INSTRUCTIONS	1
9	V-2146	LABEL, BATTERY CHARGER PLUG IN	1
10	V-2118	LABEL, SERIAL NO. (CE)	1
11	V-1999	LABEL, ISO HAND CRUSH	1
12	V-1814	LABEL, WARNING KEEP 5 FT	2
13	JP-079	FILLER, BATTERY	1
14	H-3933	COVER, PROTECTIVE	2
15	H-3931	STRAP, SAFETY	1
16	H-3930	STRAP, STRUT 36 IN	2
17	H-2899	TAPE, REFLECTIVE WHITE	8
18	H-2807-004.00	REFLECTOR, RED	16
19	H-2806	REFLECTOR, YELLOW	8
20	C-eJP12	OPERATION, MANUAL eJP12	1
21	Z-9602-01	COVER, PACKAGE, eJP12 (P)	1
22	JP-243	MIRROR, REAR VIEW SIDE	1
23	V-2726	LABEL, eJP-12	2

**Parts List**

When ordering replacement parts/kits, please specify model, serial number and color of your unit.

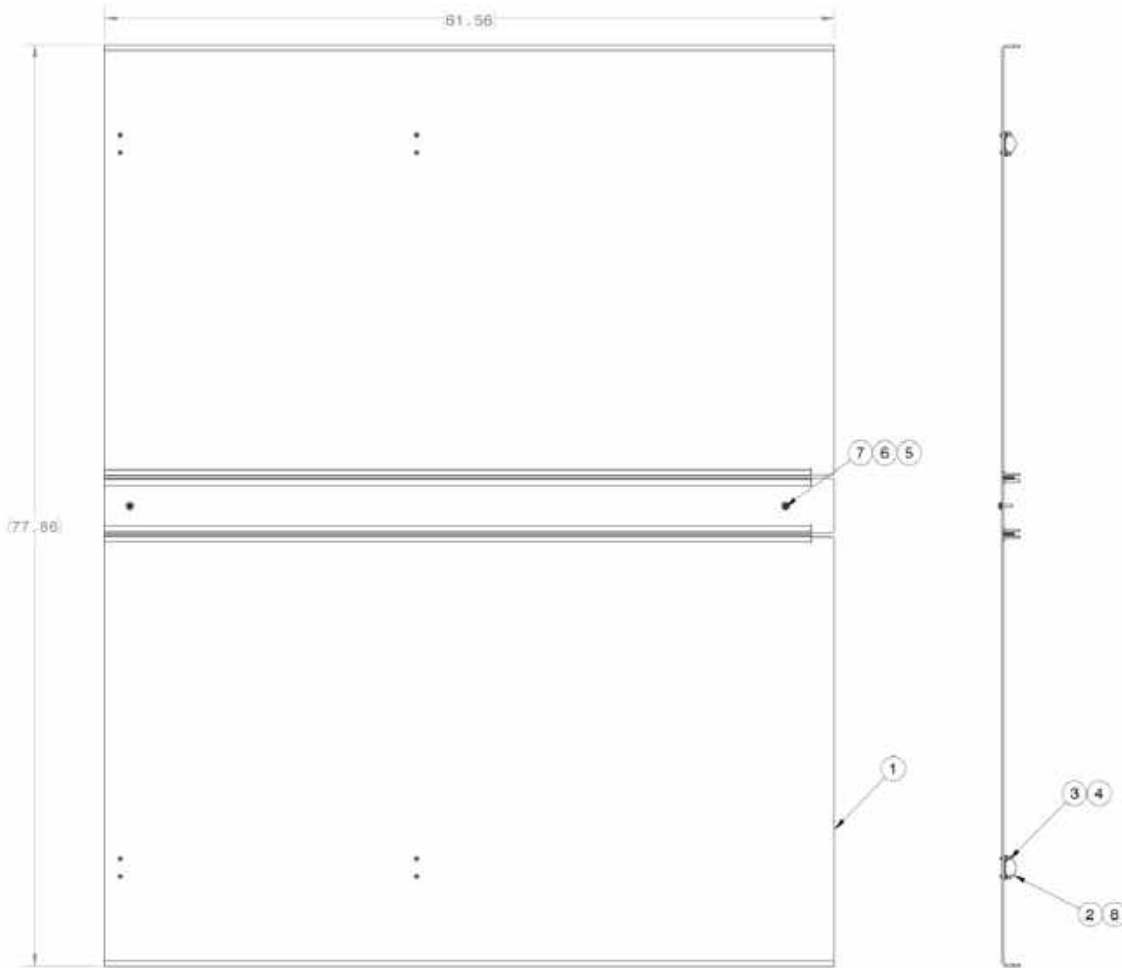

Item	Part Number	Description	Qty
1	Z-9508	ASSEMBLY, BATTERY COVER	1
2	JP-236 BRACKET	BRACKET	4
3	G-1476-103106	SCREW, #10-32 X 3/4" LG. SST SOC BUTT. HD CAP	8
4	G-1202-1035	STOPNUT, #10-32 ELASTIC	8
5	G-1503-1050N	FLATWASHER. 1/4 SST NARROW	2
6	G-1502-1050R	LOCKWASHER, 1/4 SST REGULAR	2
7	G-1476-105010	SCREW, 1/4-20 X 1.0" LG. SST SOC BUTT. HD CAP	2
8	JP-235	GAS STRUT	4

### Parts List

When ordering replacement parts/kits, please specify model, serial number and color of your unit.

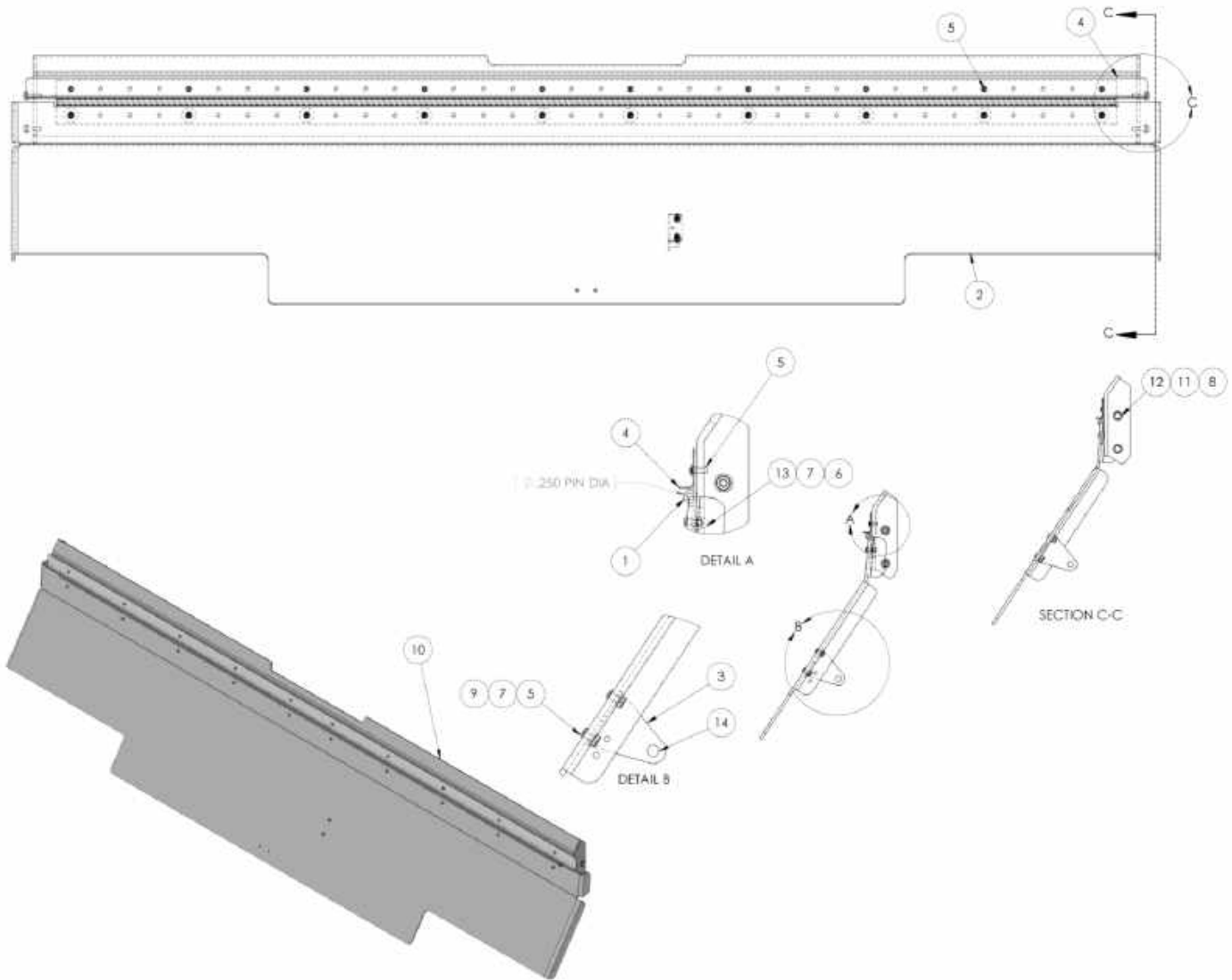

Item	Part Number	Description	Qty
1	H-3868	HINGE, PANIO	2
2	S-2905	COVER, FRONT	REF
3	H-3056	BRACKET 90 DEG W/.390 BALL	1
4	S-3205-00	TAB, HINGE (P)	1
5	G-1476-103104	SCREW, #10-32 X 1/2" LG. SST SOC BUTT. HD CAP	12
6	G-1476-103004	SCREW, #10-24 X 1/2" LG. SST SOC BUTT. HD CAP	10
7	G-1503-1030N	FLATWASHER. #10 SST NARROW	12
8	G-1503-1050N	FLATWASHER. 1/4 SST NARROW	4
9	G-1202-1035	STOPNUT, #10-32 ELASTIC	2
10	Z-9569-00/-SP	WELDMENT, COVER SHORT	REF
11	G-1502-1050R	LOCKWASHER, 1/4 SST REGULAR	4
12	G-1112-105010	BOLT, 1/4-20 X 1.0" LG SST HEX HD	4
13	G-1512-1030	NUT, 10-24 ACORN HEX (SST)	10
14	H-3882	GAS, STRUT	1

**Parts List**

When ordering replacement parts/kits, please specify model, serial number and color of your unit.

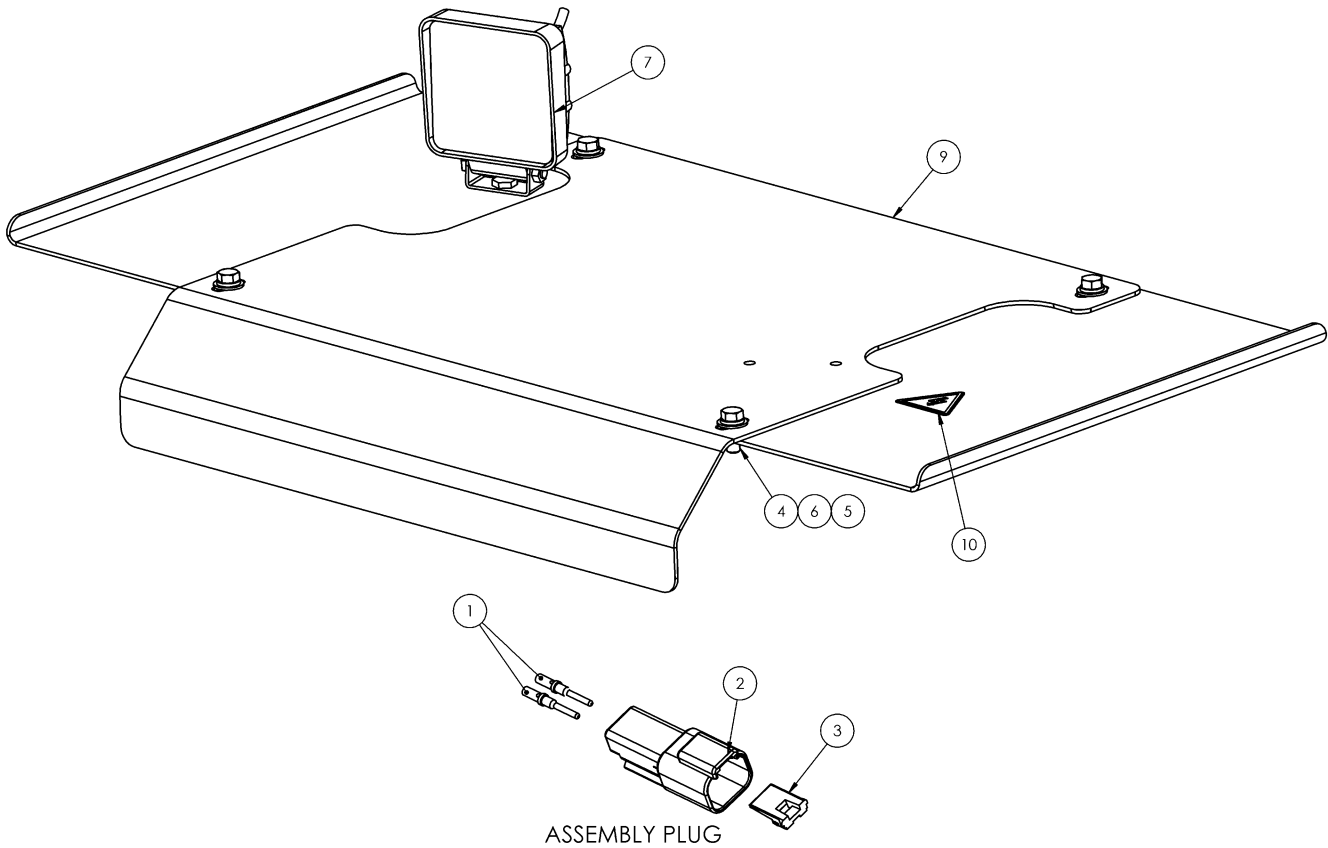

Item	Part Number	Description	Qty
1	4002-31	CONTACT PIN (16 AWG)	2
2	EC-2098	RECEPTACLE, 2 PIN	1
3	EC-2099	WEDGELOCK, 2 PIN	1
4	G-1112-107010	BOLT, 38-16 X 1.0" SST HEX HD	4
5	G-1502-1070R	LOCKWASHER, 3/8 SST REGULAR	4
6	G-1503-1070N	FLATWASHER. 3/8 SST NARROW	4
7	NVSP-34-007-CA	HEADLIGHT, LED SQ 500 LUMEN	1
8	S-2848-01	PANEL, MOTOR COVER	1
9	S-3809	WINCH, GUARD	1
10	V-1050	LABEL, ISO ELECTRICAL SHOCK	1

## Parts List

When ordering replacement parts/kits, please specify model, serial number and color of your unit.

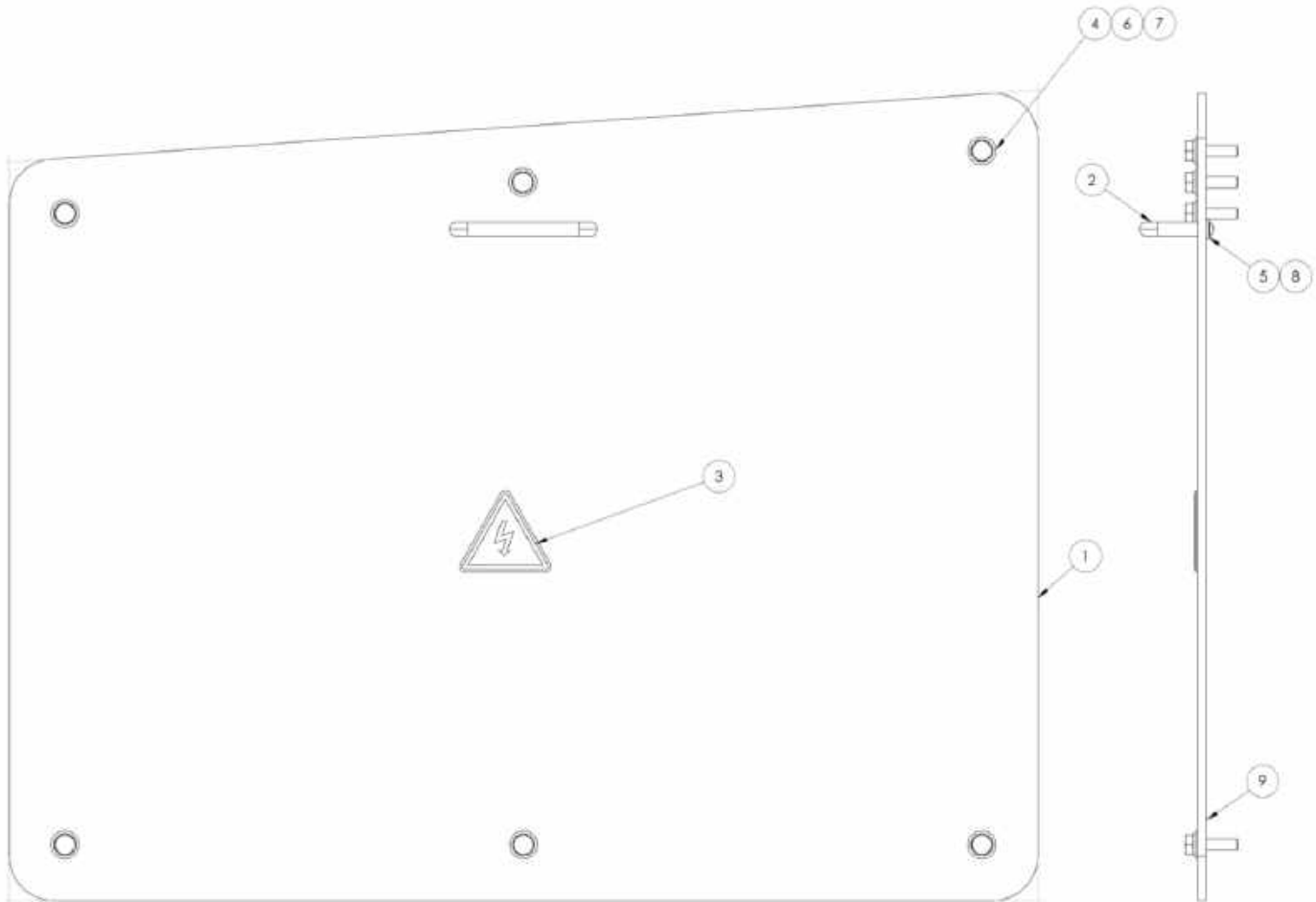

**1** NOTE: Place Item 9 (H-1204-06-81.0) outer edge of panel to seal panel to console wall of unit

Item	Part Number	Description	Qty
1	J-6379-00	PANEL, CONSOLE SIDE	REF
2	14074	HANDLE, DRAWER	1
3	V-1050	LABEL, ISO ELECTRICAL SHOCK	1
4	G-1503-1050N	FLATWASHER. 1/4 SST NARROW	6
5	G-1503-1020N	FLATWASHER. #8 SST NARROW	2
6	G-1502-1050R	LOCKWASHER, 1/4 SST REGULAR	6
7	G-1112-105010	BOLT, 1/4-20 X 1.0" LG SST HEX HD	6
8	G-1159-102004	SCREW, #8-32 X 1/2" LG. RD HEAD CROSS RECESS MACHINE	2
9	H-1204-06-81.0	TAPE, NEOPRENE FOAM SEAL	1

**Parts List**

When ordering replacement parts/kits, please specify model, serial number and color of your unit.

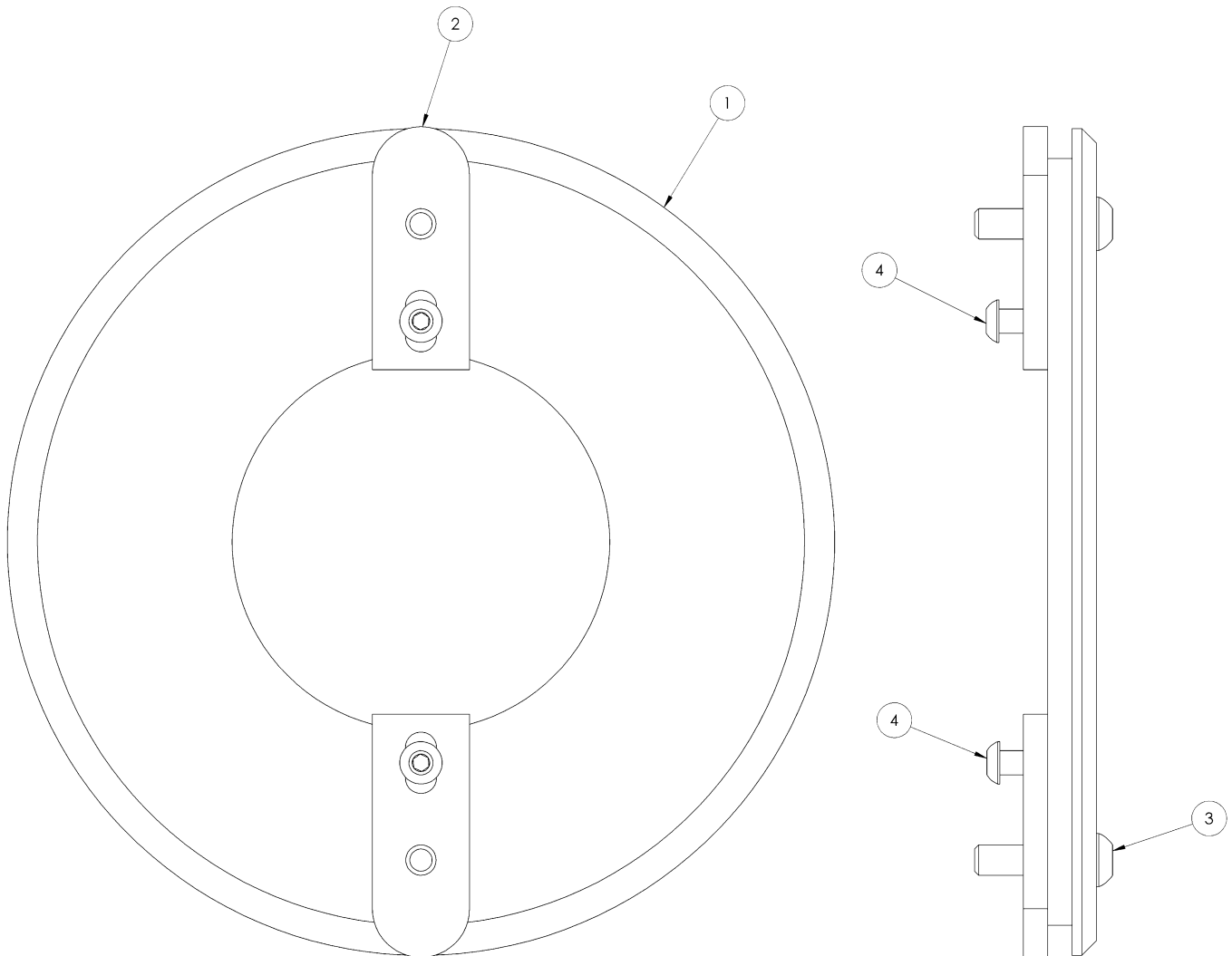

Item	Part Number	Description	Qty
1	J-6537	PLATE, COVER	1
2	J-6077-00	PLATE, HOLD DOWN ARM (P)	2
3	G-1476-106012	SCREW, 5/16-18 X 1-1/4" LG. SST SOC BUTT. HD CAP	2
4	G-1476-105006	SCREW, 1/4-20 X 3/4" LG. SST SOC BUTT. HD CAP	2

**Parts List Illustration**

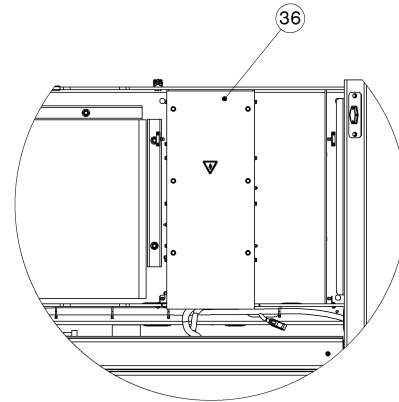

**BATTERY BOX WITH  
COVER SHOWN**

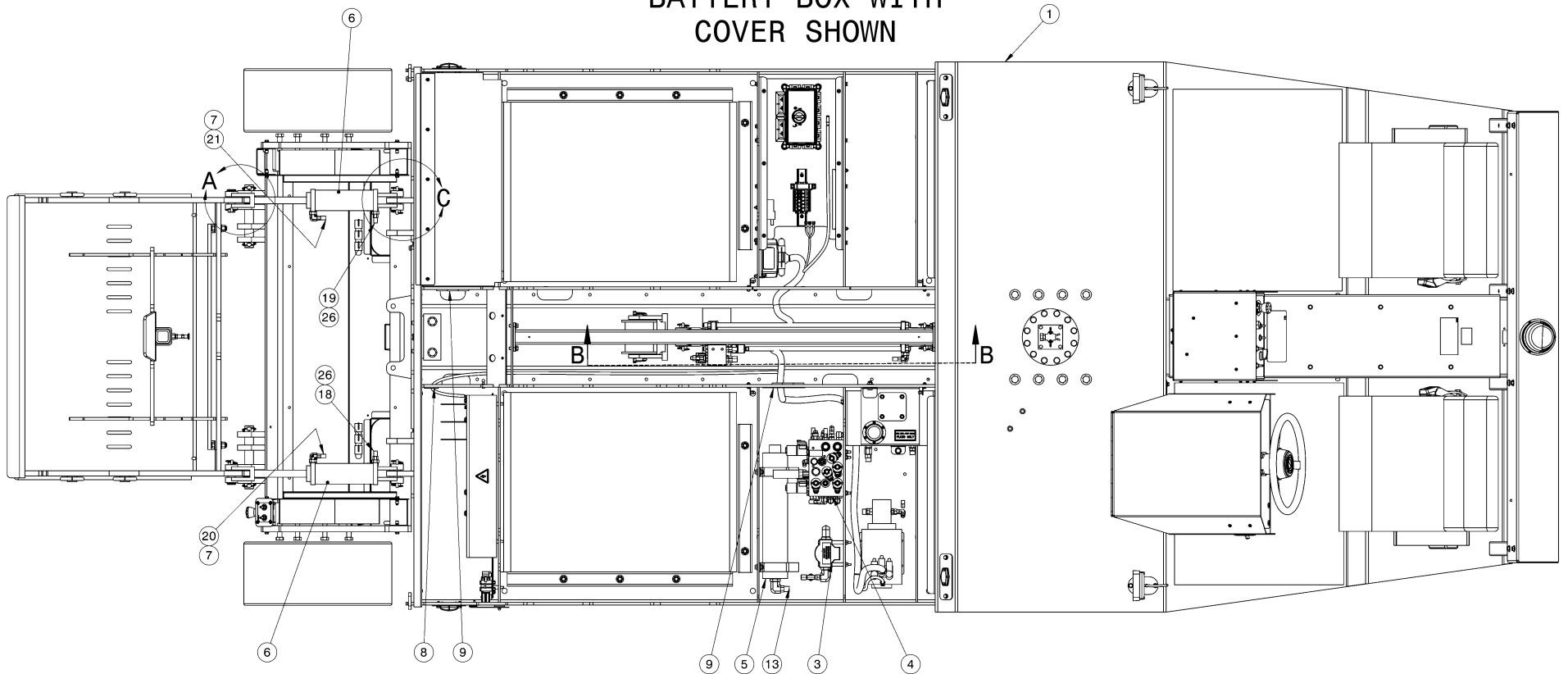

## Parts List Illustration

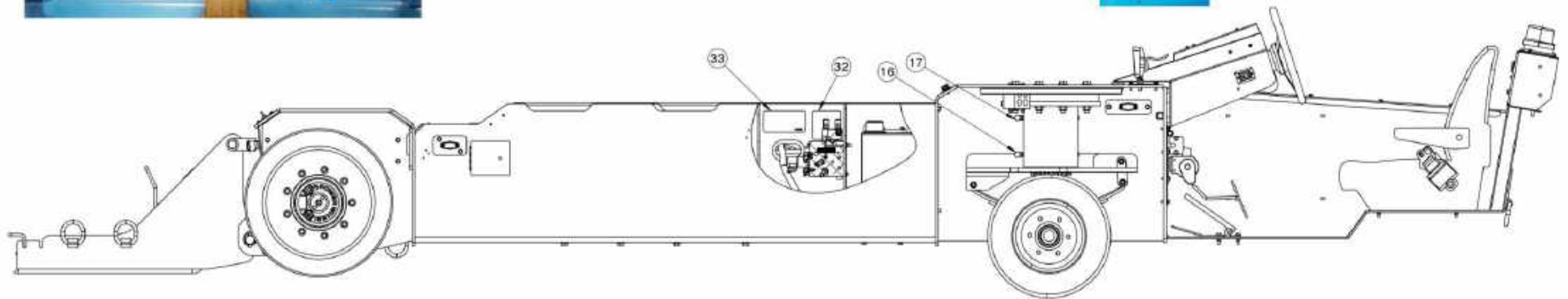
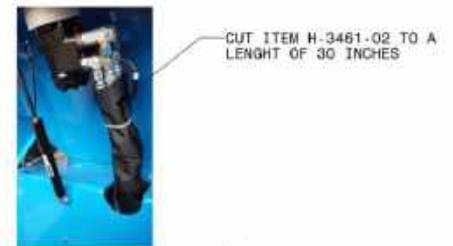
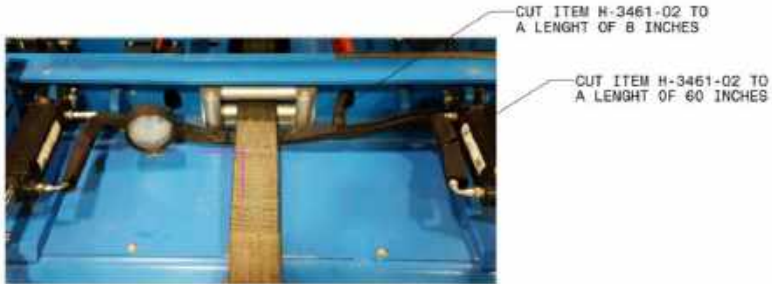

**Parts List Illustration**

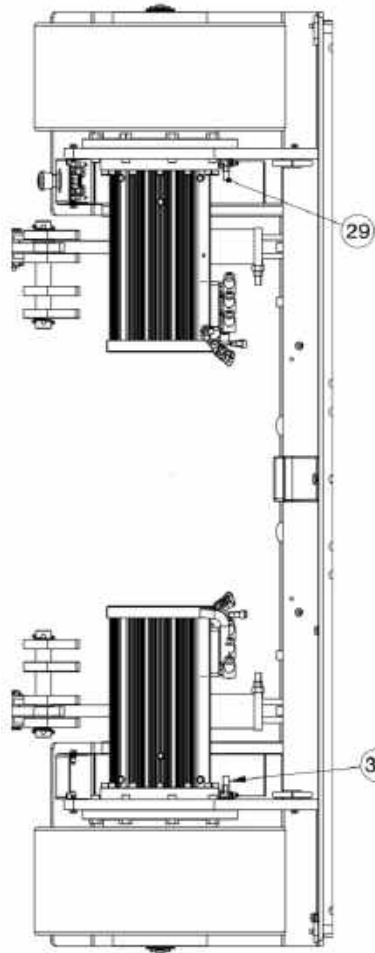

**BOTTOM VIEW**

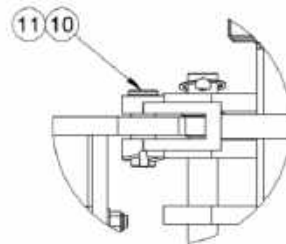

**DETAIL A PER SIDE  
CRADLE PIN**

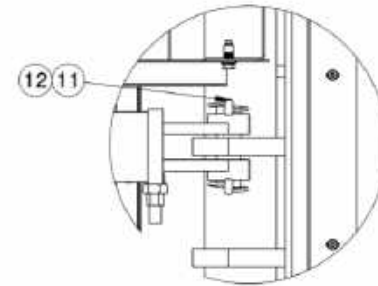

**DETAIL C  
BACK OF CYL. PIN**

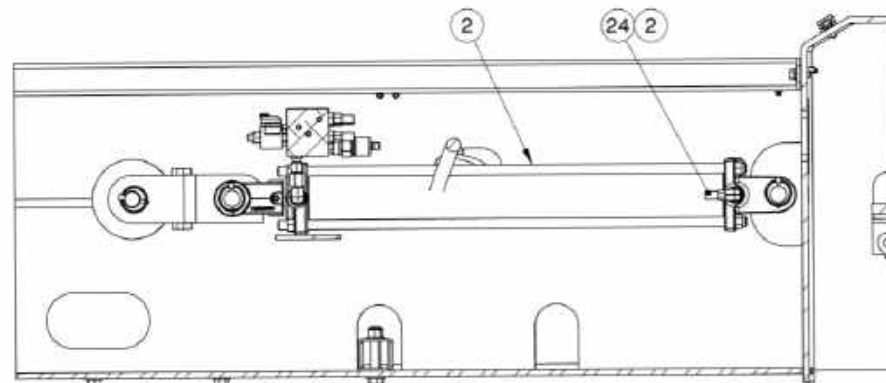

**SECTION B-B  
WINCH CYL.**

**Parts List Illustration**

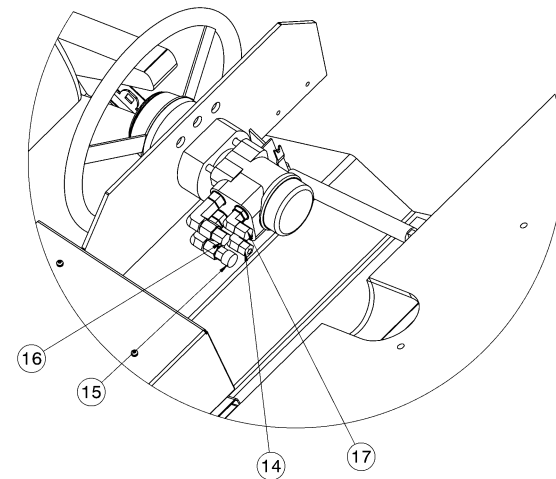
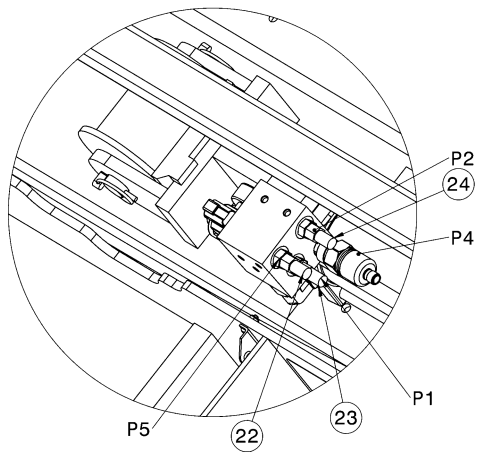
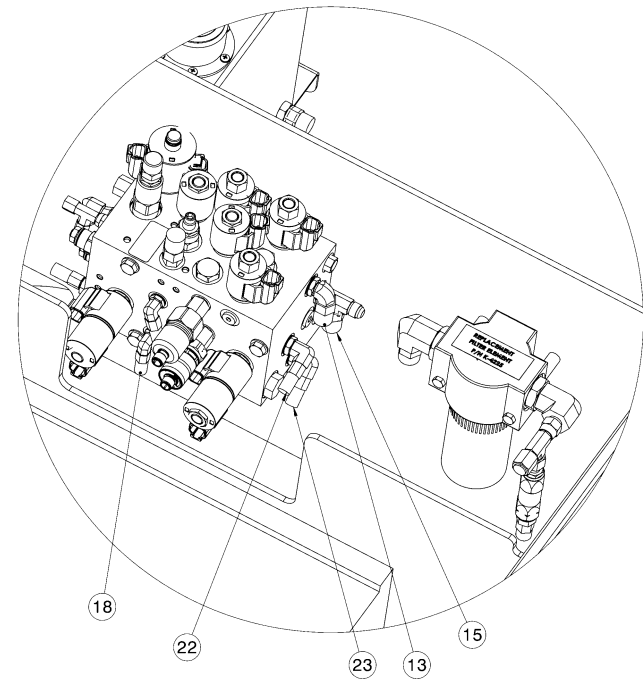
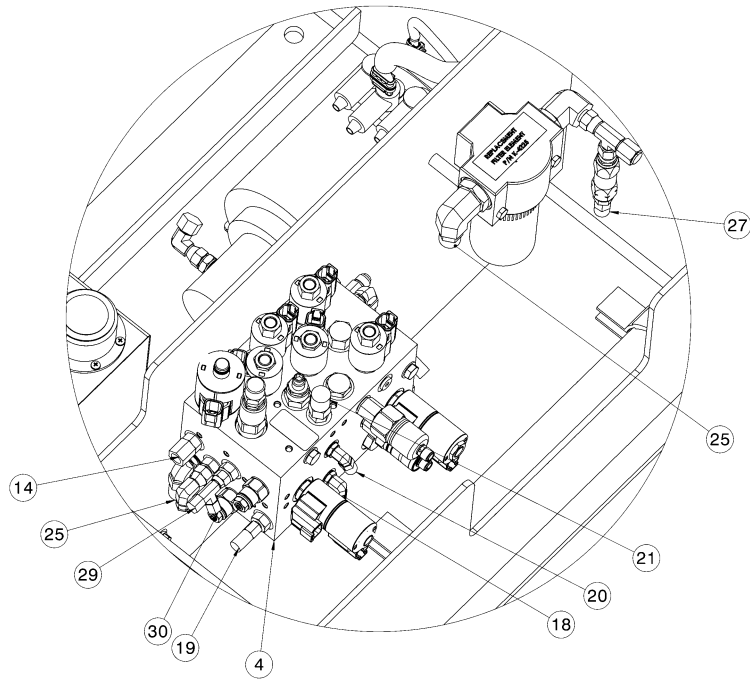

## Parts List Illustration

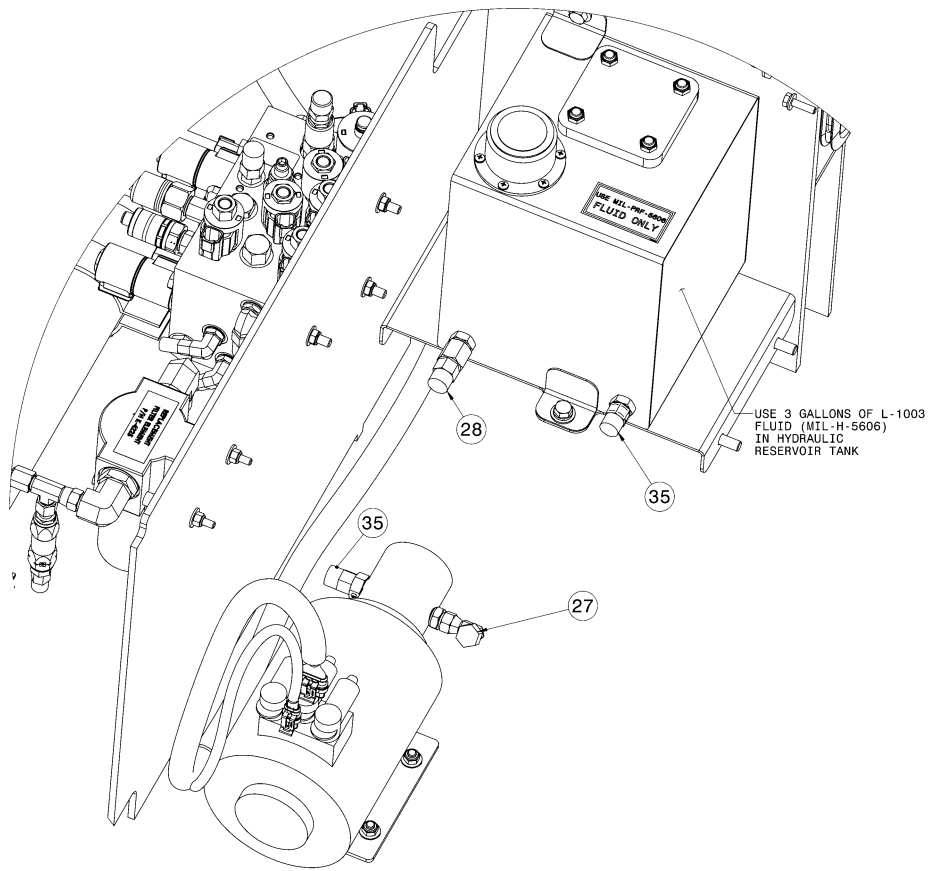

## Parts List

When ordering replacement parts/kits, please specify model, serial number and color of your unit.

Item	Part Number	Description	Qty
1	Z-9494	ASSEMBLY, INTERNAL eJP12	1
2	Z-9497	ASSEMBLY, WINCH ROLLER	1
3	Z-9251	ASSEMBLY, FILTER	1
4	Z-9285	ASSEMBLY, MAIN VALVE	1
5	Z-9252	ASSEMBLY, ACCUMULATOR	1
6	HC-2746	CYLINDER, HYDRAULIC	2
7	N-2001-06-S-B	ELBOW, STRAIGHT THREAD	2
8	H-4040-02	GROMMET, 1.5 IN. I.D. G3061	1
9	H-4040-01	GROMMET, 3.0 IN. I.D. G3319 (65 DURO,SBR)	2
10	R-3098	PIN, CYLINDER	2
11	G-1320-01	PIN, LYNCH	6
12	CYL PIN	CYL. PIN SUPPLY WITH CYL (INCLUDE WITH CYLINDER)	REF
13	Z-9532-01-1	FROM ACCUMULATOR PORT TO MAIN VALVE BLOCK P8	REF
14	Z-9532-05	FROM MAIN VALVE BLOCK P9 TO STEERING VALVE PRESSURE	REF
15	Z-9532-04	FROM MAIN VALVE BLOCK P11 TO STEERING VALVE TANK	REF
16	Z-9532-03-1	FROM STEERING VALVE LEFT TO ROTARY ACTUATOR BOTTOM PORT	REF
17	Z-9532-03-2	FROM STEERING VALVE RIGHT TO ROTARY ACTUATOR TOP PORT	REF
18	Z-9532-06-3	FROM MAIN VALVE BLOCK P3 TO CRADLE CYLINDER DRIVER SIDE BLIND END	REF
19	Z-9532-06-4	FROM MAIN VALVE BLOCK P3 TO CRADLE CYLINDER PASSENGER SIDE BLIND END	REF
20	Z-9532-09	FROM MAIN VALVE BLOCK P4-1 TO CRADLE CYLINDER DRIVER'S SIDE ROD END	REF
21	Z-9532-10	FROM MAIN VALVE BLOCK P4 TO CRADLE CYLINDER PASSENGER'S SIDE ROD END	REF
22	Z-9532-07-1	FROM MAIN VALVE BLOCK P5 TO WINCH VALVE BLOCK P5	REF
23	Z-9532-07-2	FROM MAIN VALVE BLOCK P6 TO WINCH VALVE BLOCK P1	REF
24	Z-9532-08	FROM WINCH VALVE BLOCK P2 TO WINCH CYLINDER BLIND END PORT	REF
25	Z-9532-01-2	FROM FILTER OUTLET PORT TO MAIN VALVE BLOCK P	REF
26	N-2007-06-S-B	CONNECTOR, STR THD	2
27	Z-9532-02	FROM PUMP PRESSURE PORT TO FILTER INLET PORT	1
28	Z-9532-13	FROM MAIN BLOCK "T" TO PUMP RETURN PORT	1
29	Z-9532-06-1	FROM MAIN BLOCK P10 TO PARKING BRAKE MASTER SIDE	1
30	Z-9532-11	FROM MAIN BLOCK P10-2 TO PARKING BRAKE SLAVE SIDE	1
31	H-3461-02	FLEXABLE, SLEEVE COVER 1-1/2 ID	128
32	V-2711	LABEL, ELECTRICAL FAILURE	1
33	V-2651	LABEL, ELECTRICAL FAILURE WINCH	1
34	Z-9586	ASSEMBLY, HYDRAULIC RESERVOIR	1
35	Z-9532-12	FROM TANK SUPPLY (RIGHT SIDE) TO PUMP SUPPLY	1
36	Z-10754	ASSEMBLY, TERMINAL COVER	1

## Parts List

When ordering replacement parts/kits, please specify model, serial number and color of your unit.

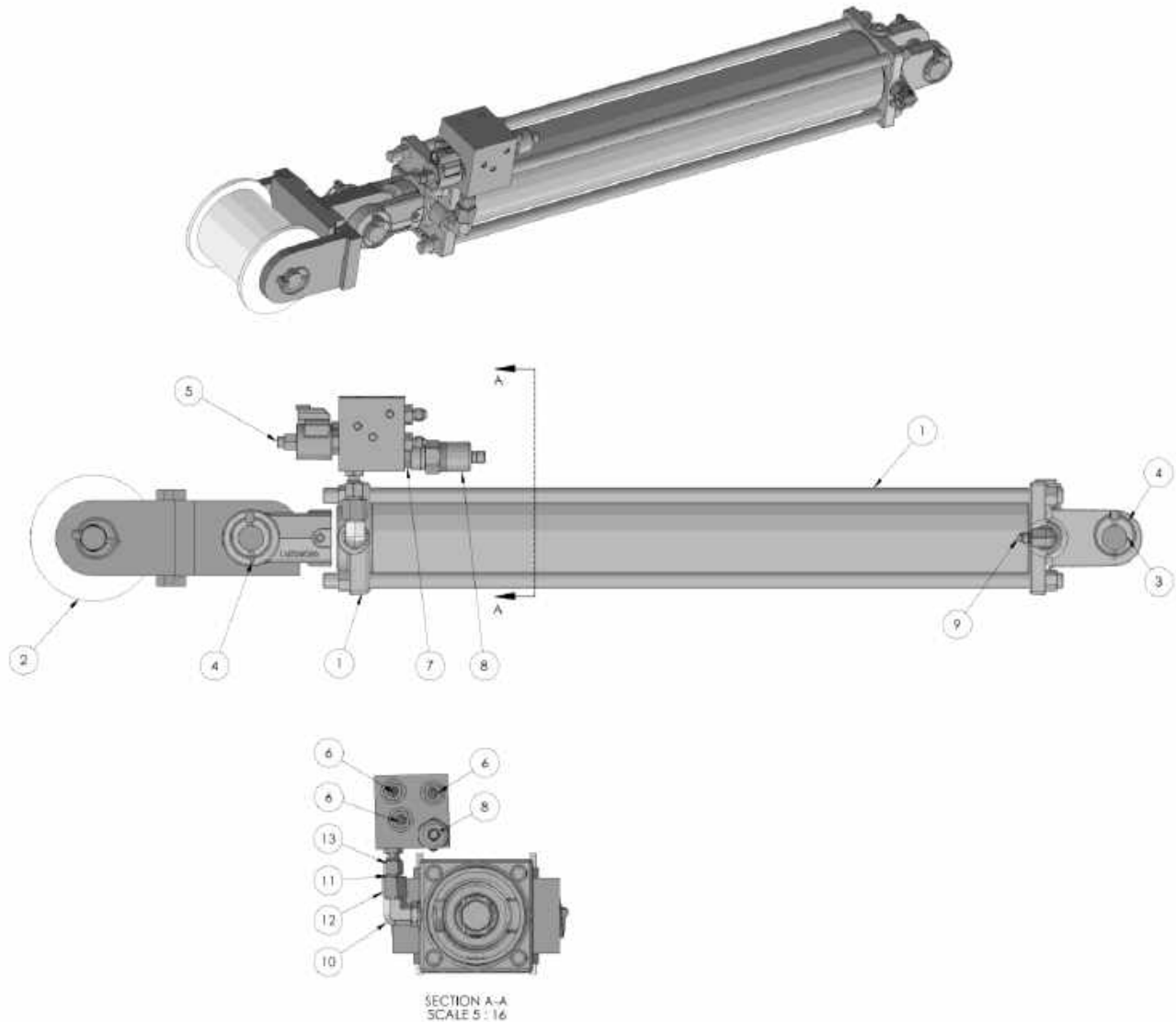

Item	Part Number	Description	Qty
1	HC-2687	CYLINDER, HYDRAULIC 3.5 X 24IN	1
2	Z-9045	ASSEMBLY, WINCH ROLLER	1
3	CYL PIN	COMW WITH CYLINDER	-2
4	G-1320-01	PIN, LYNCH	4
5	HC-2743	ASSEMBLY, CYLINDER VALVES	1
6	N-2007-05-S-B	CONNECTOR, STR THD	3
7	N-2987	BSPP #4 SAE/ORB x 1/4" MALE	1
8	HC-2690	PRESSURE, SENSOR	1
9	N-2001-06-S-B	ELBOW, STRAIGHT THREAD	1
10	N-2001-11-S-B	ELBOW, STRAIGHT THREAD	1
11	N-2020-03-S	REDUCER, TUBE END	1
12	N-2000-06-S	NUT, #8 JIC X 37 DEG	1
13	N-2036-03-S-B	SWIVEL, 37 DEG FEMALE	1

## Parts List

When ordering replacement parts/kits, please specify model, serial number and color of your unit.

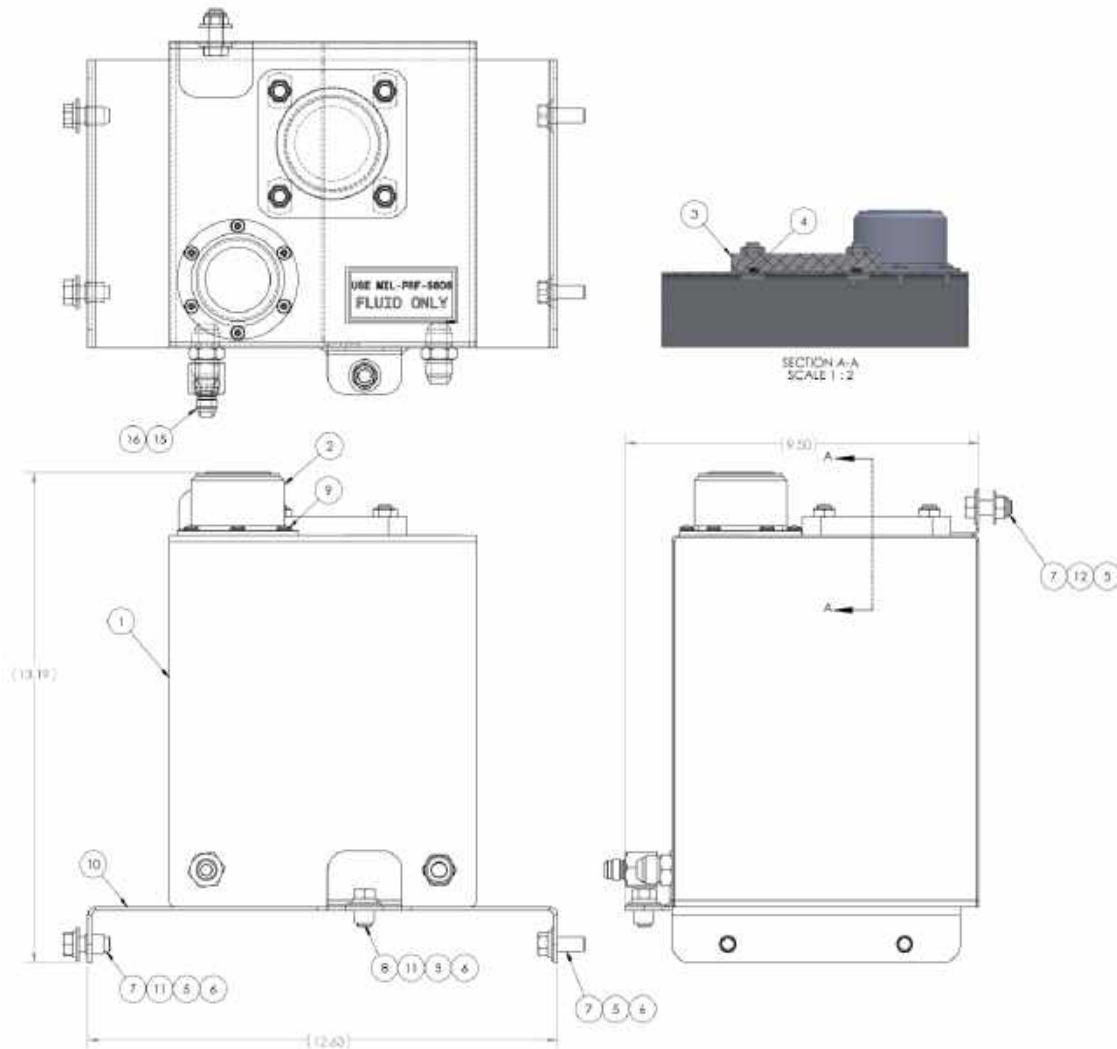

Item	Part Number	Description	Qty
1	Z-9517	WELDMENT, CONTAINER 2 GAL	1
2	HC-1030-01	FILLER-BREATHER NON VENTED	1
3	J-6543	CAP, CLEAN OUT	1
4	HC-2006-334	O-RING, SERIES 2	1
5	G-1503-1070N	FLATWASHER, 3/8 SST NARROW	7
6	G-1502-1070R	LOCKWASHER, 3/8 SST REGULAR	5
7	G-1112-107010	BOLT, 38-16 X 1.0" SST HEX HD	5
8	G-1112-107006	BOLT, 38-16 X 3/4" SST HEX HD	1
9	G-1157-103504	SCREW, #10-32 X 1/2" LG PAN HD CROSS RECESS	6
10	S-3241	BRACKET, ANGLE (P)	1
11	G-1439-1070-S	NUTSERT, 10-32 OPEN END	3
12	G-1202-1070	STOPNUT, 3/8-16 ELASTIC	1
13	G-1203-1070	JAMNUT, 3/8-16 ELASTIC	4
14	V-1102	LABEL, MIL-PRF-5606	1
15	N-2020-03-S	REDUCER, TUBE END	1
16	N-2000-06-S	NUT, #8 JIC X 37 DEG	1

**Parts List**

When ordering replacement parts/kits, please specify model, serial number and color of your unit.

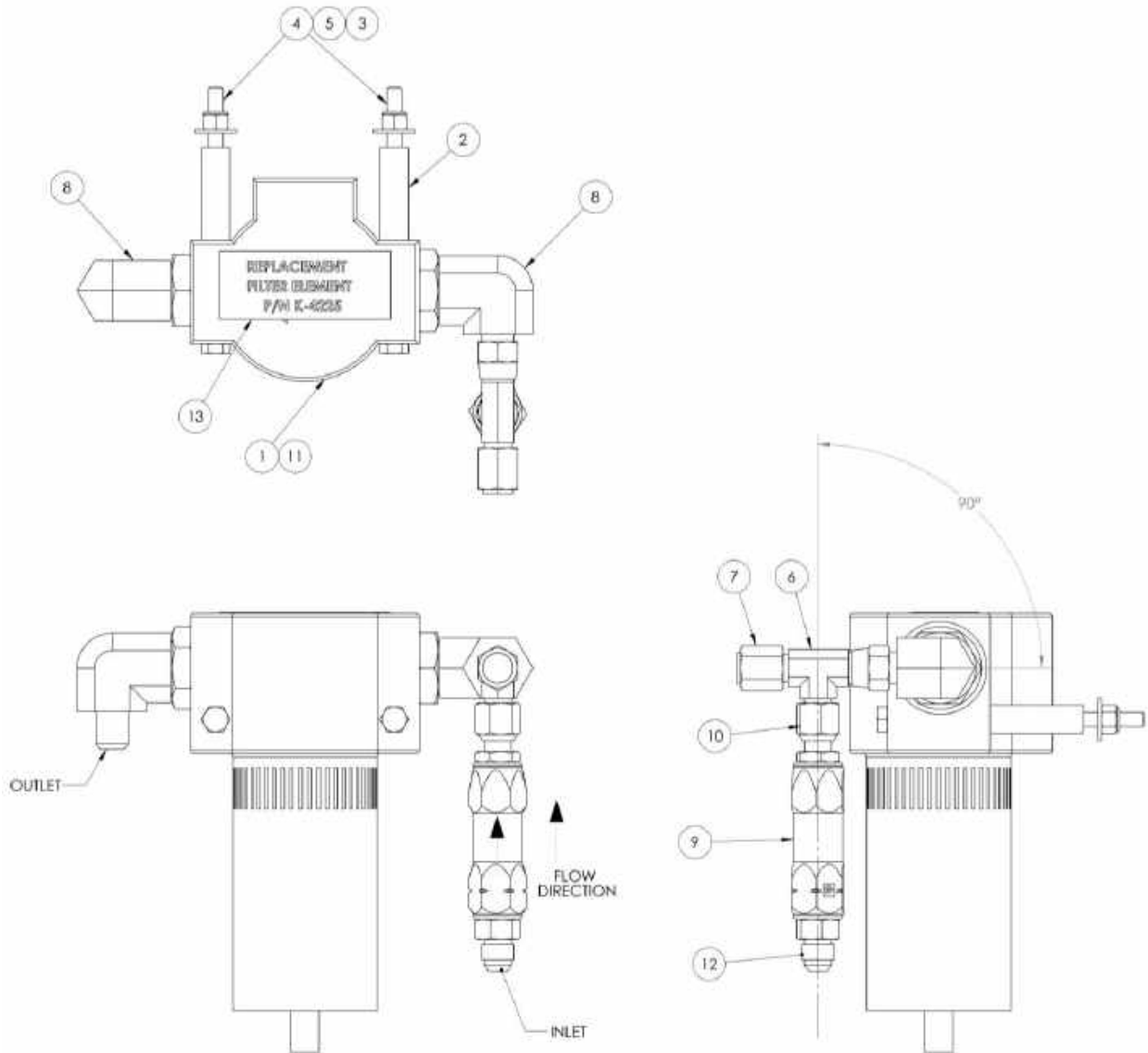

Item	Part Number	Description	Qty
1	HC-1244	BODY, FILTER-4	1
2	TR377-03-001.63	TBG, SST .500D-.049W	2
3	G-1250-1050W	FLATWASHER. #8 WIDE	2
4	G-1100-105544	BOLT, 1/4-28 X 4-1/2" LG HEX HD GR 5	2
5	G-1202-1055	STOPNUT, 1/4-28 ELASTIC	2
6	N-2016-05-S	TEE, RUN SWIVEL NUT	1
7	N-2008-05-S	CAP, 3/8	1
8	N-2001-39-S-B	ELBOW, STR THD (MB)	2
9	HC-1731-04-005	VALVE, CHECK (INLINE)	1
10	N-2036-03-S-B	SWIVEL, 37 DEG FEMALE	1
11	HC-1322	ELEMENT, FILTER	1
12	N-2007-08-S-B	CONNECTOR, STR THD	1
13	V-2231	LABEL, FILTER ELEMENT REPLACEMENT	1

This page left blank intentionally.

**Parts List**

When ordering replacement parts/kits, please specify model, serial number and color of your unit.

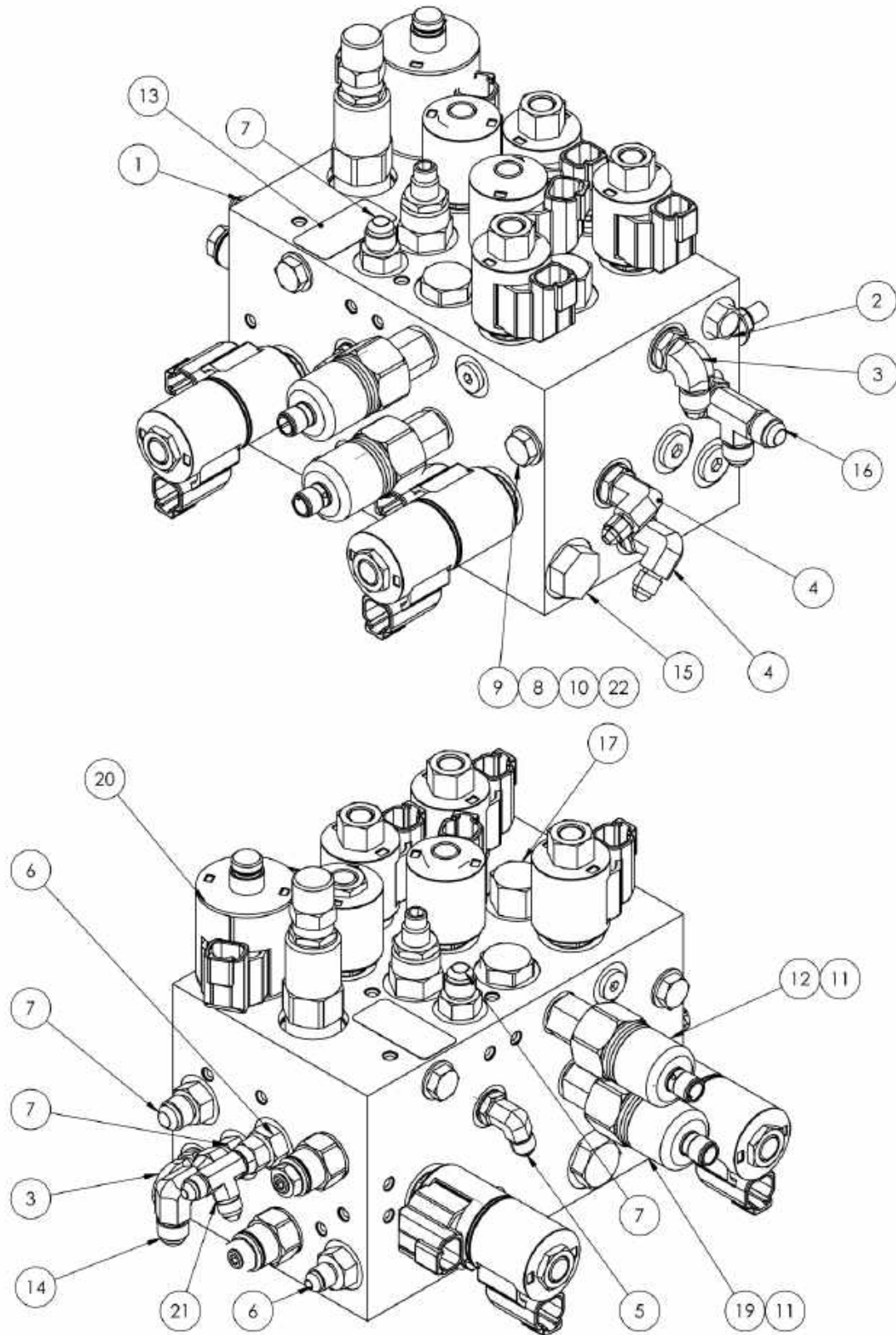

### Parts List

When ordering replacement parts/kits, please specify model, serial number and color of your unit.

Item	Part Number	Description	Qty
1	HC-2742	ASSEMBLY, VALVE MANIFOLD	1
2	N-2053-03-S-B	PLUG, HEX HD W/O-RING	1
3	N-2001-08-S-B	ELBOW, STRAIGHT THREAD	2
4	N-2001-05-S-B	ELBOW, STRAIGHT THREAD	2
5	N-2001-03-S-B	ELBOW, STRAIGHT THREAD	2
6	N-2007-05-S-B	CONNECTOR, STR THD	2
7	N-2007-08-S-B	ADAPTER, -06 JIC M X -06 ORB M	3
8	G-1503-1060N	FLATWAHER, 5/16 NARROW S.S.	6
9	G-1112-106060	BOLT, 5/16-18 X 6.0" LG. SST HEX HD	3
10	G-1202-1060	STOPNUT, 5/16-18 ELASTIC	3
11	N-2846-02	FITTING, ADAPTOR	2
12	EC-2204-PGM-4	PRESSURE SENSOR, PROGRAMMED	1
13	V-2710	LABEL, LOWERING CRADLE	1
14	N-2002-05-S	ELBOW, -06 M JIC X -06 F JIC	1
15	N-2053-06-S-B	PLUG, HEX HD W/O-RING	1
16	N-2015-08-S-B	TEE, RUN STR THD	1
17	HC-2742-10_	FLOW, CONTROL PRESSURE COMP	1
18	N-2008-05-S-E	CAP, 3/8	1
19	EC-2204-PGM-5	PRESSURE SENSOR, PROGRAMMED	1
20	EC-3307	VAKVE, PROPORTIONAL	1
21	N-2016-03-S	TEE, RUN SWIVEL NUT	1
22	G-1513-1060N	FLATWASHER, THRU HARD N	3

**Parts List**

When ordering replacement parts/kits, please specify model, serial number and color of your unit.

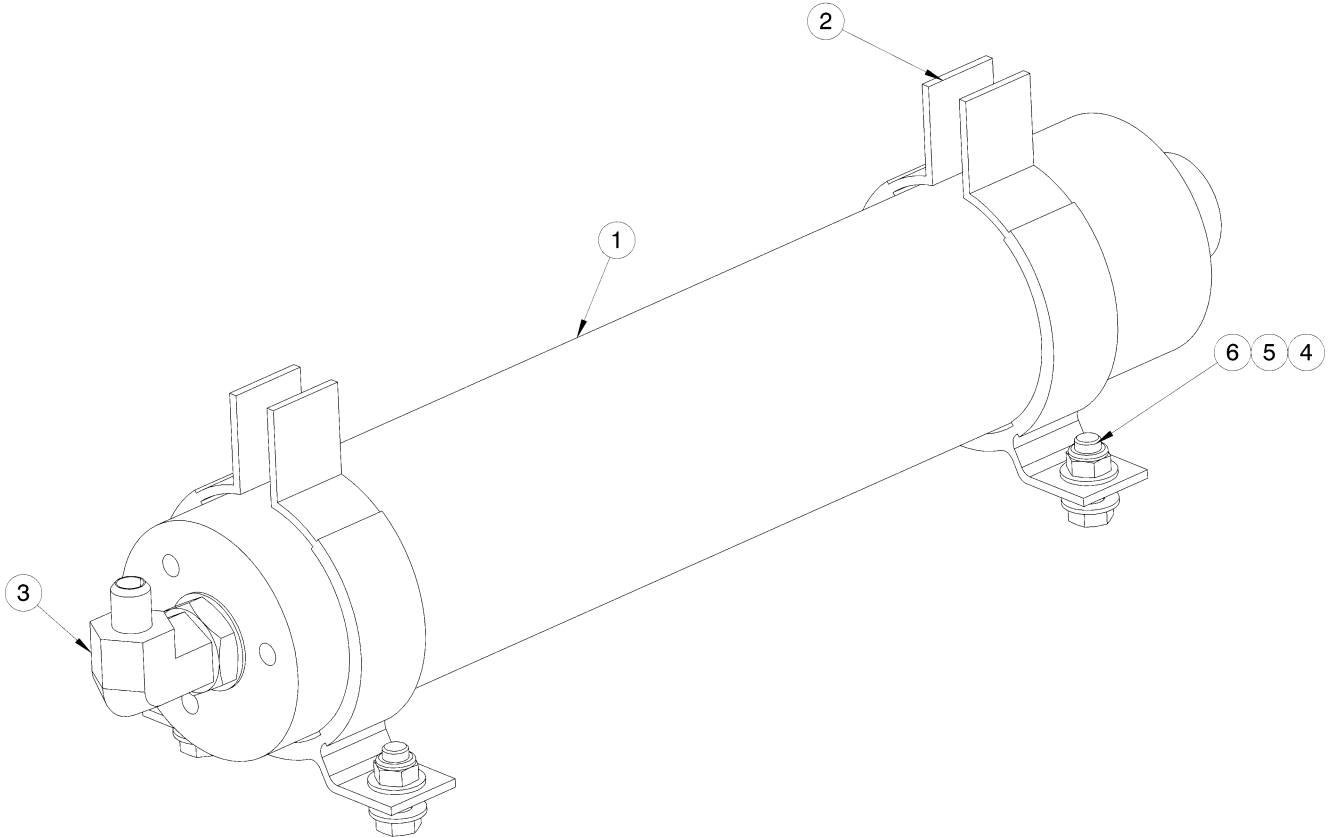

Item	Part Number	Description	Qty
1	HC-2747	ACCUMULATOR	1
2	H-3074-04	BRACKET, CLAMP	2
3	N-2001-39-S B	ELBOW, STR THD	1
4	G-1250-1070N	FLATWASHER. 3/8 NARROW	8
5	G-1202-1070	STOPNUT, 3/8-16 ELASTIC	4
6	G-1100-107010	BOLT, 3/8-16 X 1.0" HEX HD GR 5	4

**Parts List Illustration**

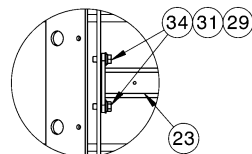
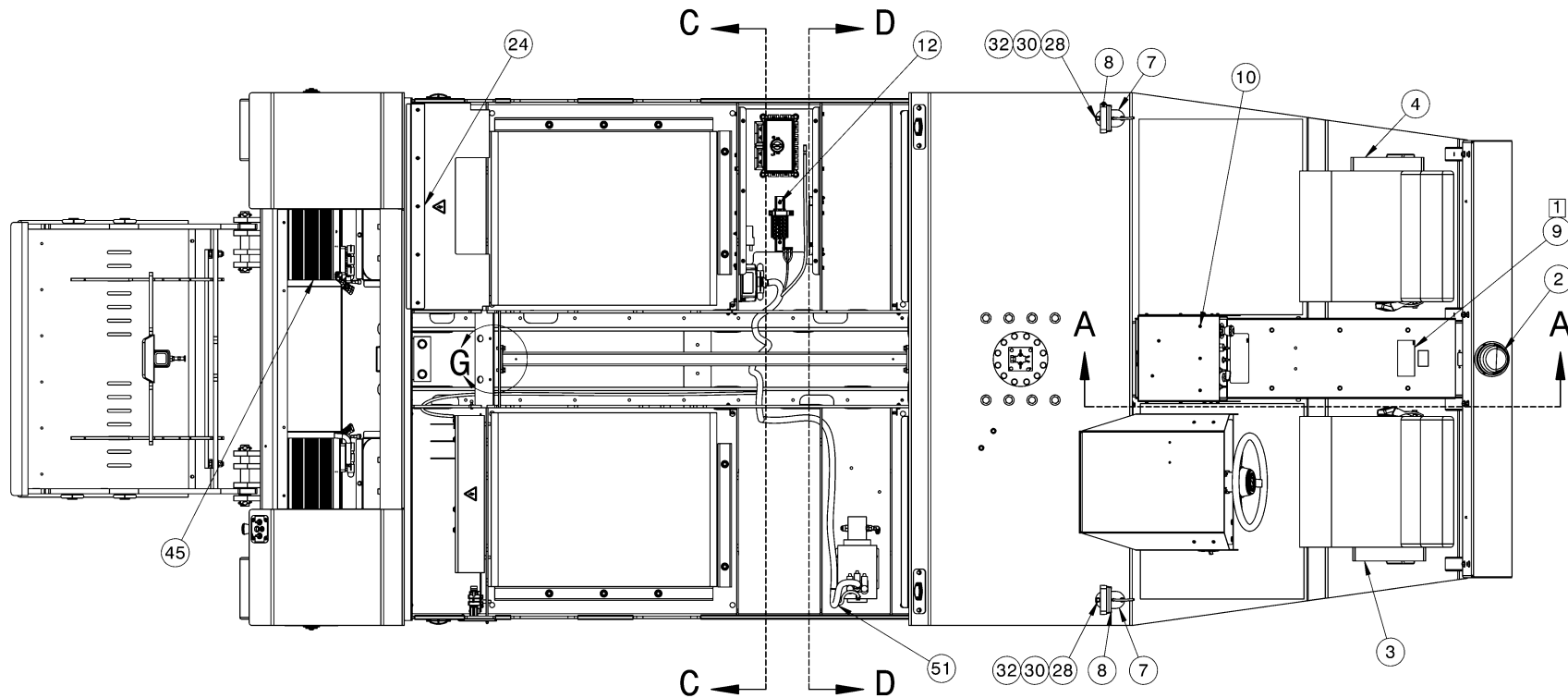

**DETAIL G**  
**SCALE 1 : 8**

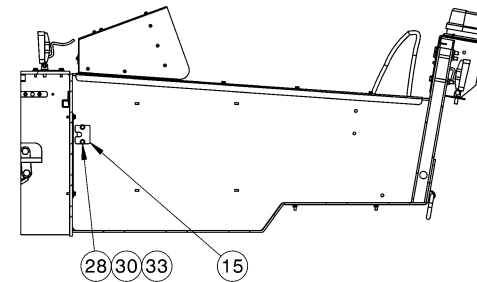

**SECTION A-A**

**Parts List Illustration**

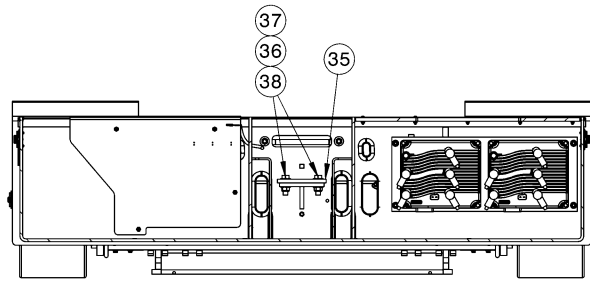

**SECTION E-E**

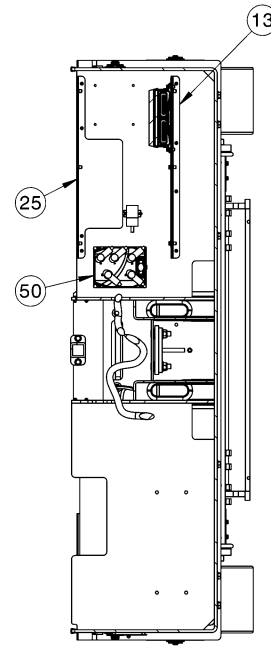

**SECTION C-C**

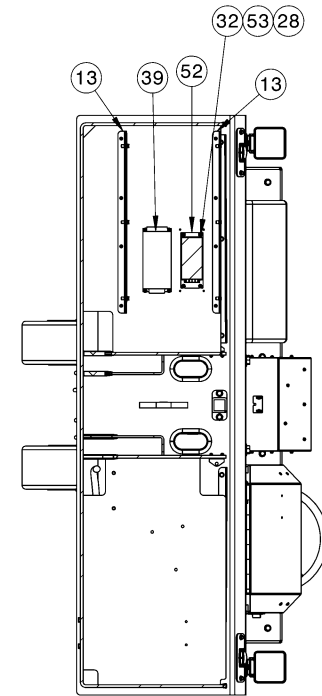

**SECTION D-D**

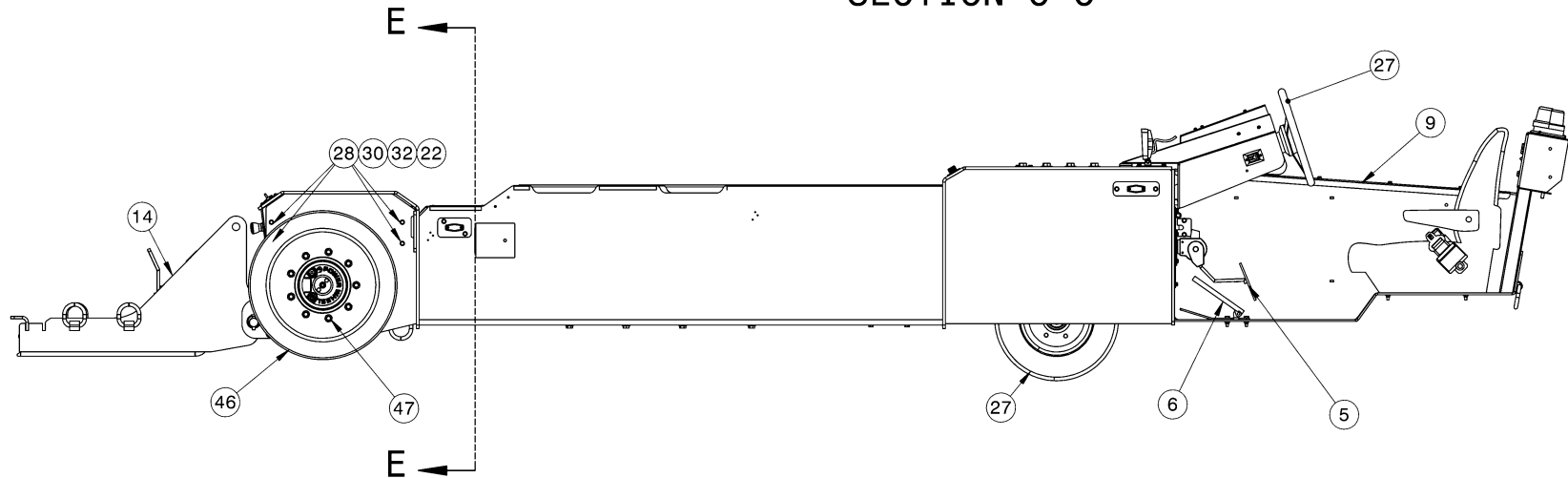

**Parts List Illustration**

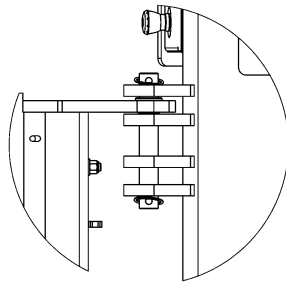

**DETAIL B**

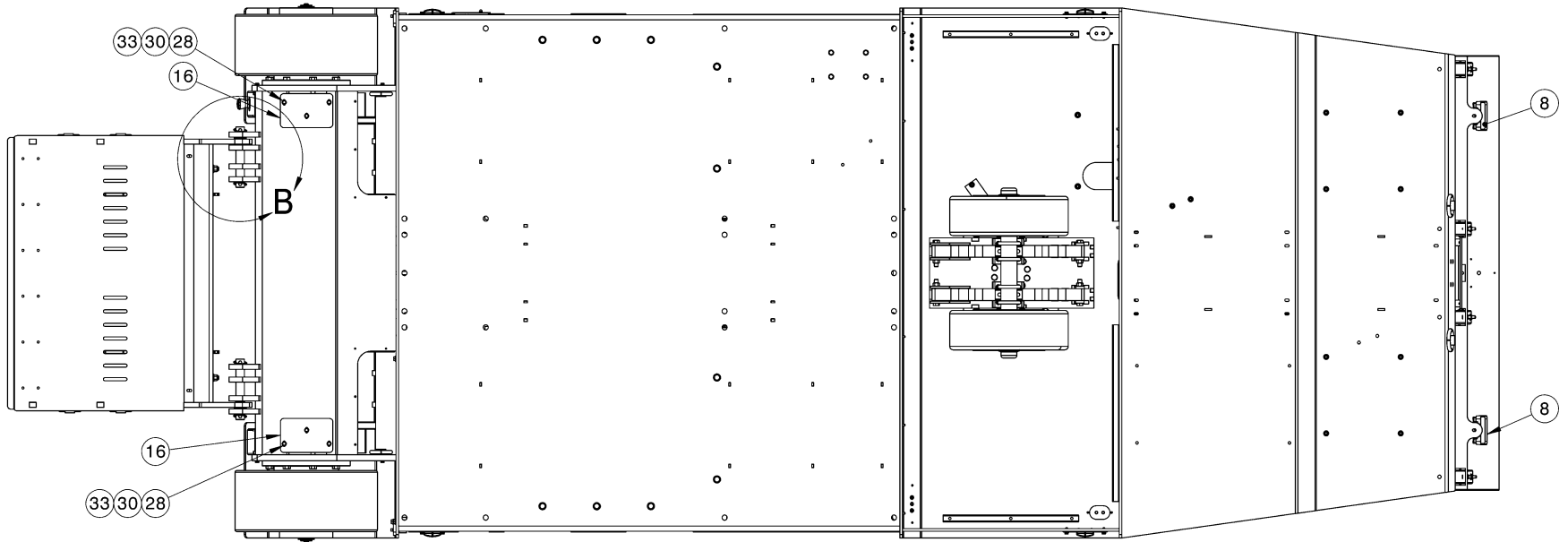
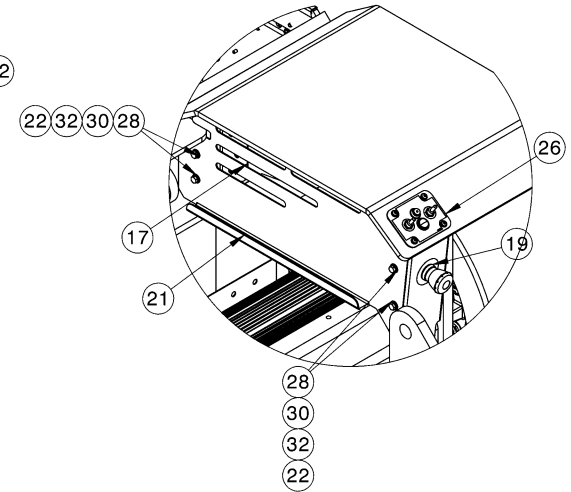
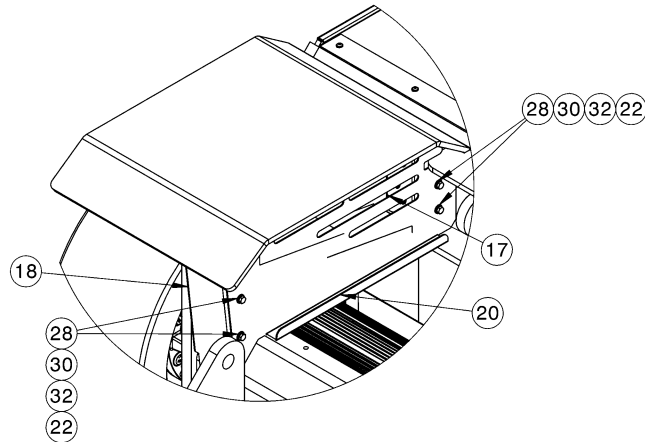

**Parts List Illustration**

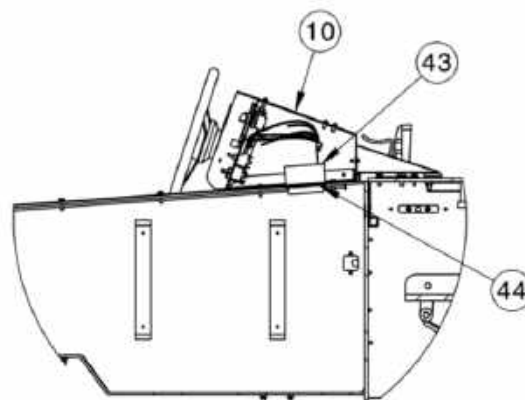
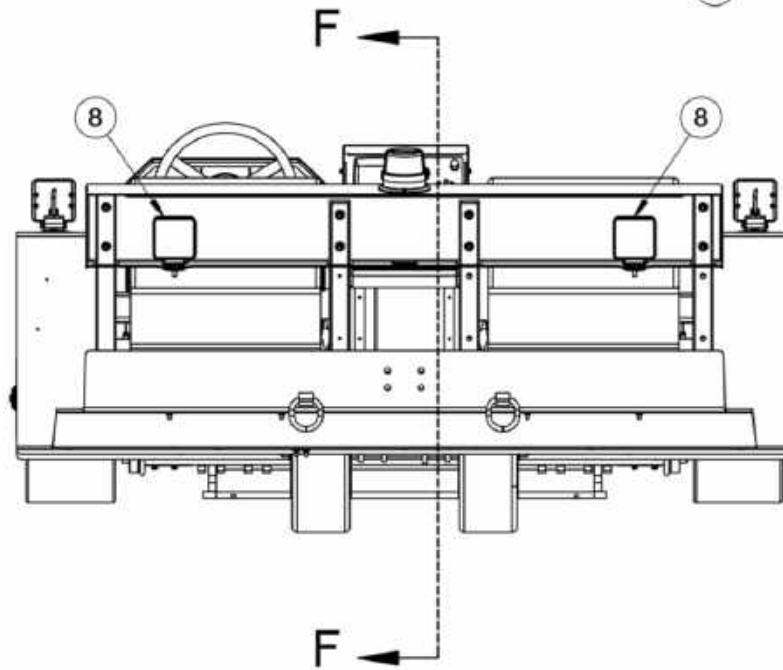
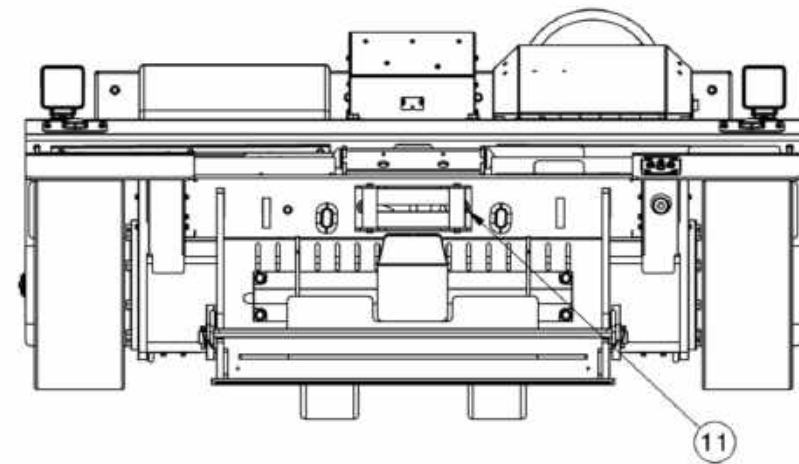

**SECTION F-F**

## Parts List

When ordering replacement parts/kits, please specify model, serial number and color of your unit.

Item	Part Number	Description	Qty
1	Z-9488	ASSEMBLY, BATTERY BOX	1
2	Z-9289	ASSEMBLY, STROBE LIGHT	1
3	Z-9283-01	ASSEMBLY, SEAT DRIVERS SIDE	1
4	Z-9283-02	ASSEMBLY, SEAT DRIVERS SIDE	1
5	Z-9294	ASSEMBLY, BRAKE PEDAL	1
6	Z-9288	ASSEMBLY, FOOT PEDAL	1
7	S-2598-01	PLATE, BASE LIGHT 11 GA	2
8	NVSP-34-007-CA	HEADLIGHT, LED SQ 500 LUMEN	4
9	Z-9281	ASSEMBLY, CONSOLE COVER	1
10	Z-9496	ASSY, CENTER CONTROL PANEL	1
11	Z-9282	ASSY, WINCH ROLLER 4 IN WIDE	1
12	Z-9295	ASSEMBLY, ELECTRICAL	1
13	Z-9286	ASSEMBLY, SUPPORT BRACKET	3
14	Z-8899	ASSEMBLY, CRADLE	1
15	S-2597-01	PLATE, COVER	1
16	S-2846-01	PLATE, COVER MOTOR BOTTOM	2
17	S-2879-01	BRACKET, REAR	2
18	S-2873-01	BRACKET, RIGHT	1
19	Z-9051	ASSEMBLY, FENDER E-STOP	1
20	Z-8950-01	WELDMENT, PANEL SIDE RT (P)	1
21	Z-8951-01	WELDMENT, PANEL SIDE LT (P)	1
22	G-1440-1050-S	NUTSERT, 1/4-20 OPEN END	16
23	Z-8841-01	WELDMENT, BRACE (P)	-1
24	Z-9510	ASSEMBLY, COVER CONTACT	1
25	Z-9501	ASSEMBLY, BRACKET	1
26	Z-10857	ASSEMBLY, FENDER SWITCHES	1
27	Z-9470	ASSEMBLY, STEERING	1
28	G-1503-1050N	FLATWASHER. 1/4 SST NARROW	32
29	G-1503-1070N	FLATWASHER. 3/8 SST NARROW	4
30	G-1502-1050R	LOCKWASHER, 1/4 SST REGULAR	28
31	G-1502-1070R	LOCKWASHER, 3/8 SST REGULAR	4
32	G-1112-105010	BOLT, 1/4-20 X 1.0" LG SST HEX HD	24
33	G-1112-105006	BOLT, 1/4-20 X 3/4" LG SST HEX HD	8
34	G-1112-107010	BOLT, 3/8-16 X 1.0" SST HEX HD	4
35	J-3881-01	PLATE, WINCH STRAP CLAMP	1
36	G-1250-1100N	FLATWASHER, 5/8 NARROW	4
37	G-1202-1105	STOPNUT, 5/8-18 ELASTIC	2
38	G-1420-110522	BOLT, 5/8-18 X 2-1/4" HEX HD GR 8	2
39	EC-2991	CONVERTER, 72VDC/12VDC	1
40	G-1250-1020N	FLATWASHER, #8 NARROW	8
41	G-1159-102006	SCREW, #8-32 X 3/4" LG. RD HEAD CROSS RECESS MACHINE	4
42	G-1202-1020	STOPNUT, #8-32 ELASTIC	4
43	EC-2993-09	ADAPTER, CONDUIT	1
44	EC-1176-09	LOCKNUT, CONDUIT	1
45	Z-9573	ASSEMBLY, MOTOR	1
46	U-1188	ASSEMBLY, WHEEL TIRE	2
47	G-1550	NUT, 5/8-18 TAPERED LUG	18
48	EC-3012	HARNESS, eJP10 DASH	1
49	EC-3055	HARNESS, LAYOUT eJP12	1
50	Z-9502	ASSEMBLY, PUMP CONTROLLER	1
51	EC-3056	PUMP MOTOR WIRING HARNESS	1
52	EC-3286	CONVERTER 72/24 VDC	1
53	G-1202-1050	STOPNUT, 1/4-20 ELASTIC	4
54	EC-3304	CAN WIRE HARNESS	1

**Parts List**

When ordering replacement parts/kits, please specify model, serial number and color of your unit.

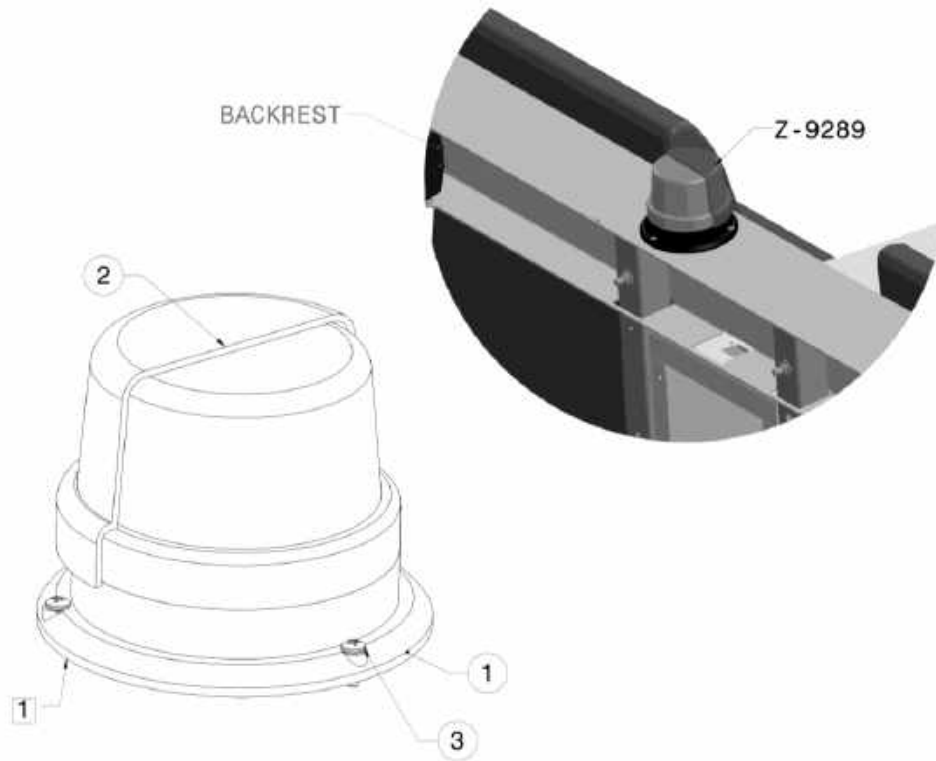

Item	Part Number	Description	Qty
1	JP-118	STOBE, LIGHT	1
2	JP-166	COVER, STROBE LIGHT	1
3	G-1497-102004	SCREW, #8-32 X 1/2" LG SST RD PH	3

**Parts List**

When ordering replacement parts/kits, please specify model, serial number and color of your unit.

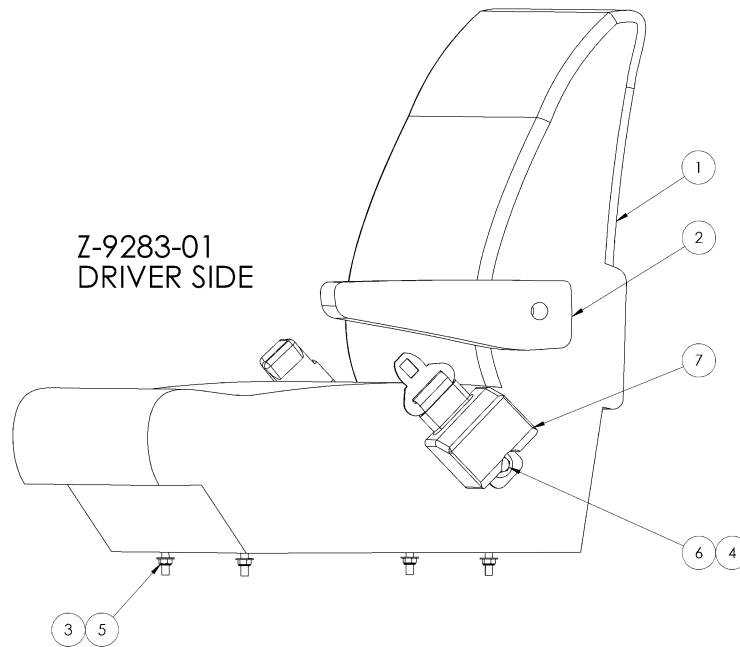
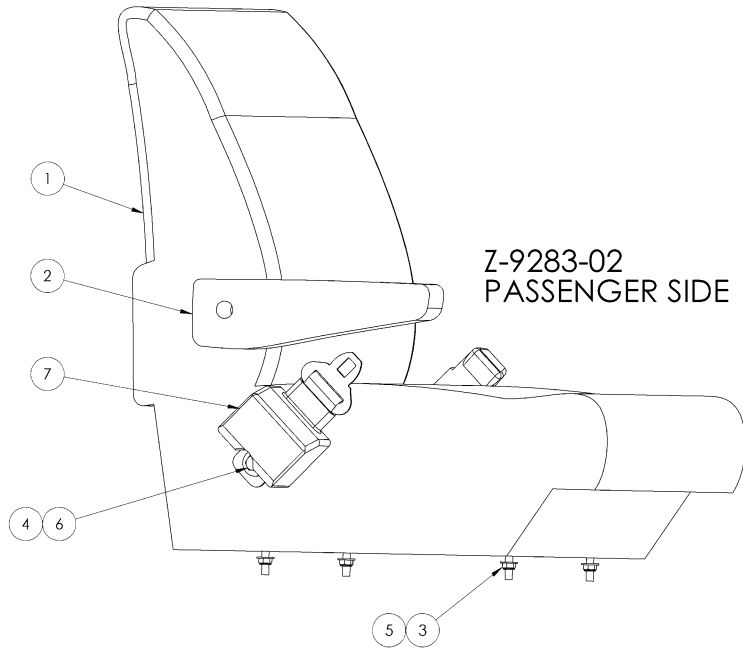

Item	Part Number	Description	Qty
1	JP-227	SEAT	1
2	JP-228	ARM REST	1
3	G-1503-1060N	FLATWASHER. 5/16 SST NARROW	4
4	G-1503-1080N	FLATWASHER. 7/16 SST NARROW	2
5	G-1501-1060	STOPNUT, 5/16-18 SST ELASTIC	4
6	G-1100-108510	BOLT, 7/16-20 X 1.0" HEX HD GR 5	2
7	JP-229-1	REEL, SEAT BELT	1

**Parts List**

When ordering replacement parts/kits, please specify model, serial number and color of your unit.

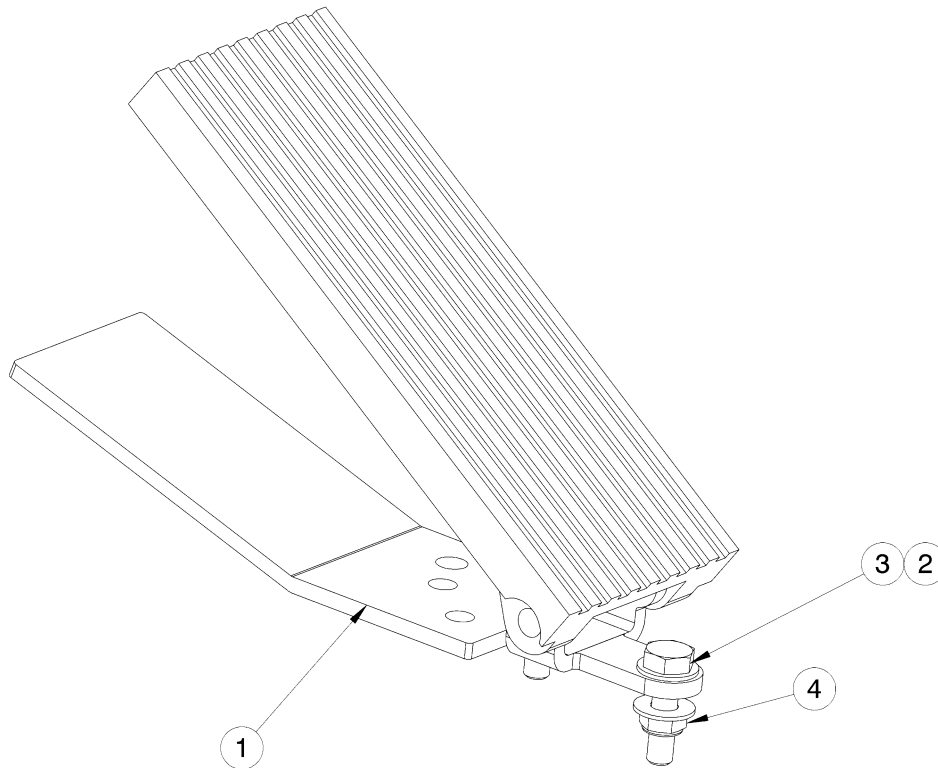

Item	Part Number	Description	Qty
1	EC-2766	FOOT, PEDAL	1
2	G-1503-1060N	FLATWASHER. 5/16 SST NARROW	4
3	G-1112-106012	BOLT, 5/16-18 X 1-1/4" LG. SST HEX HD	2
4	G-1202-1060	STOPNUT, 5/16-18 ELASTIC	4

**Parts List**

When ordering replacement parts/kits, please specify model, serial number and color of your unit.

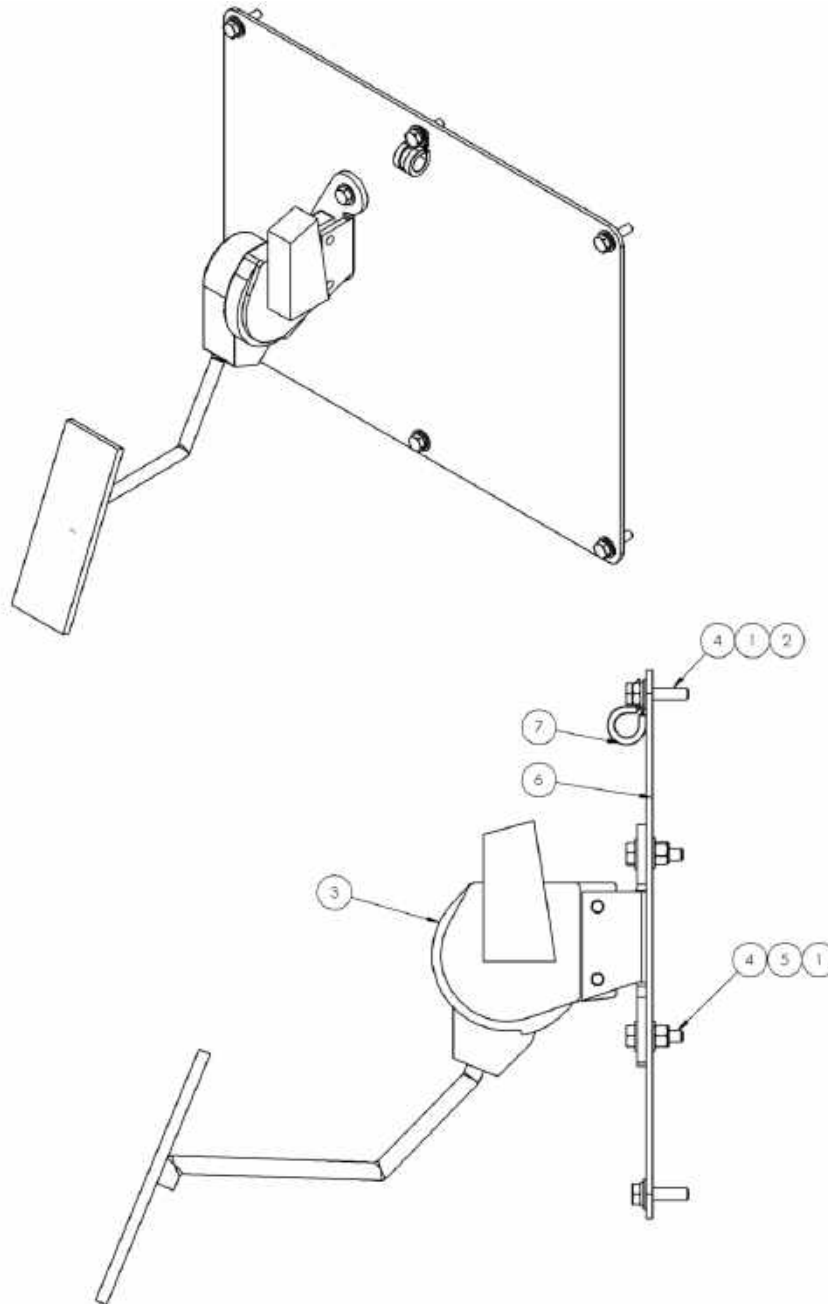

Item	Part Number	Description	Qty
1	G-1503-1050N	FLATWASHER. 1/4 SST NARROW	11
2	G-1502-1050R	LOCKWASHER, 1/4 SST REGULAR	6
3	EC-2985	MODIFIED, PEDAL FOOT EC-2961	1
4	G-1112-105010	BOLT, 1/4-20 X 1.0" LG SST HEX HD	8
5	g-1202-1050	STOPNUT, 1/4-20 ELASTIC	2
6	J-6184-01	PANEL, BRAKE	1
7	H-1721-01	CLAMP, ELECTRICAL	1

## Parts List

When ordering replacement parts/kits, please specify model, serial number and color of your unit.

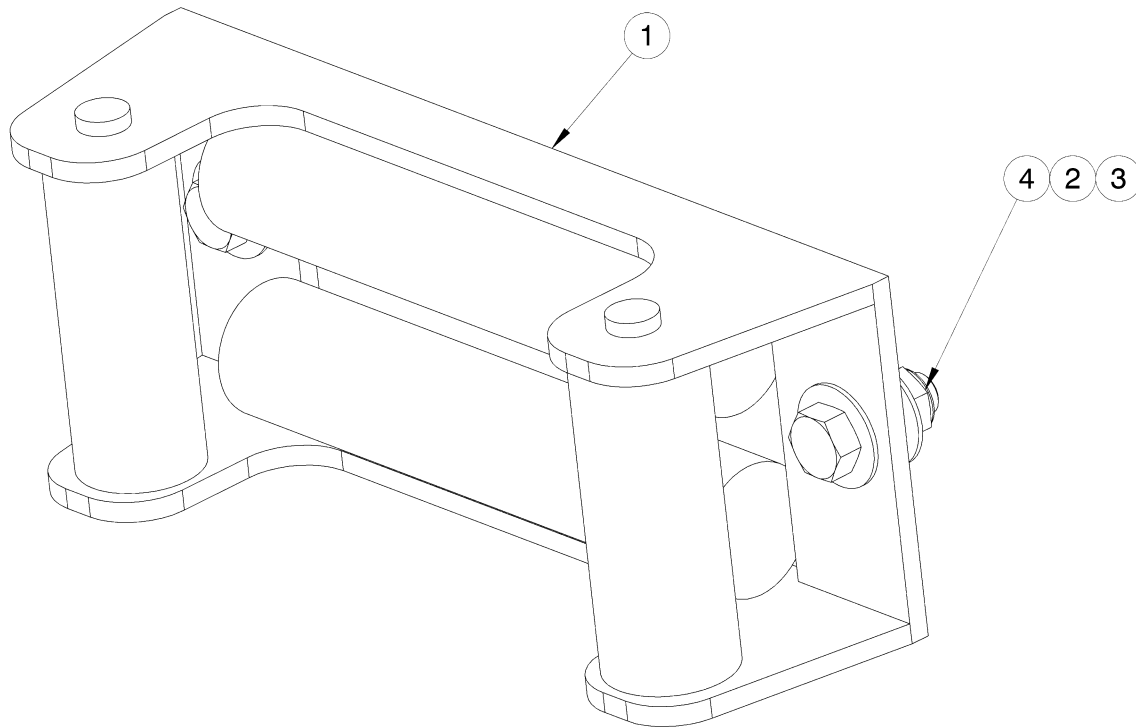

Item	Part Number	Description	Qty
1	JP-234	FAIRLEAD, ROLLER	1
2	G-1503-1090N	FLATWASHER, 1/2 SST NARROW	4
3	G-1420-109513	BOLT, 1/2-20 X 1-3/8" HEX HD GR 5	2
4	G-1202-1095	STOPNUT, 1/2-20 ELASTIC	2

**Parts List**

When ordering replacement parts/kits, please specify model, serial number and color of your unit.

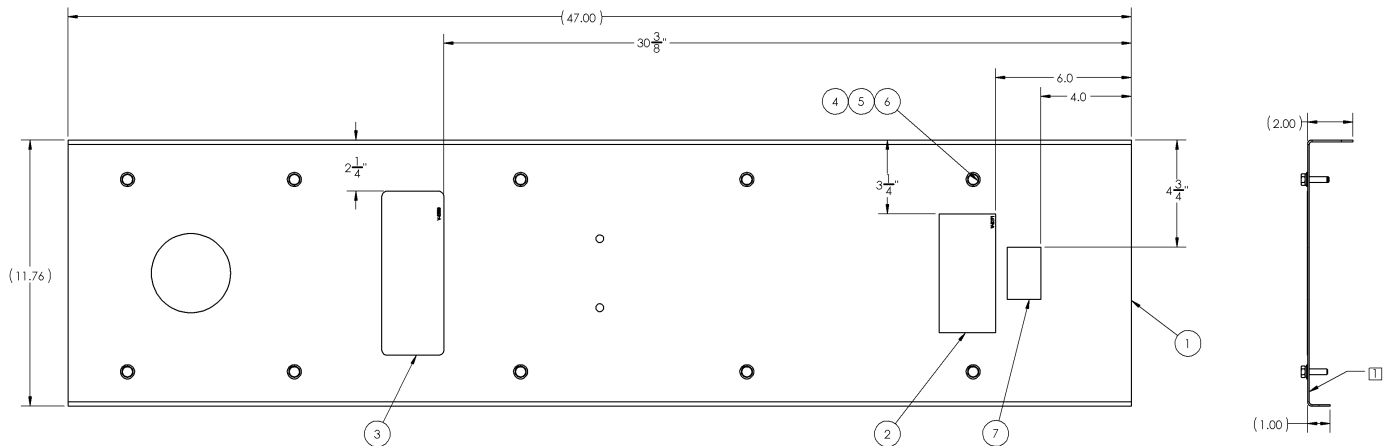

Item	Part Number	Description	Qty
1	J-6374-01	PANEL, CONSOLE TOP (P)	1
2	V-2191	LABEL, CAUTION HAND/FEET	1
3	V-2553	LABEL, E-STOP	1
4	G-1503-1050N	FLATWASHER. 1/4 SST NARROW	10
5	G-1502-1050R	LOCKWASHER, 1/4 SST REGULAR	10
6	G-1112-105010	BOLT, 1/4-20 X 1.0" LG SST HEX HD	10
7	V-1001	LABEL, MADE IN USA	1

**Parts List Illustration**

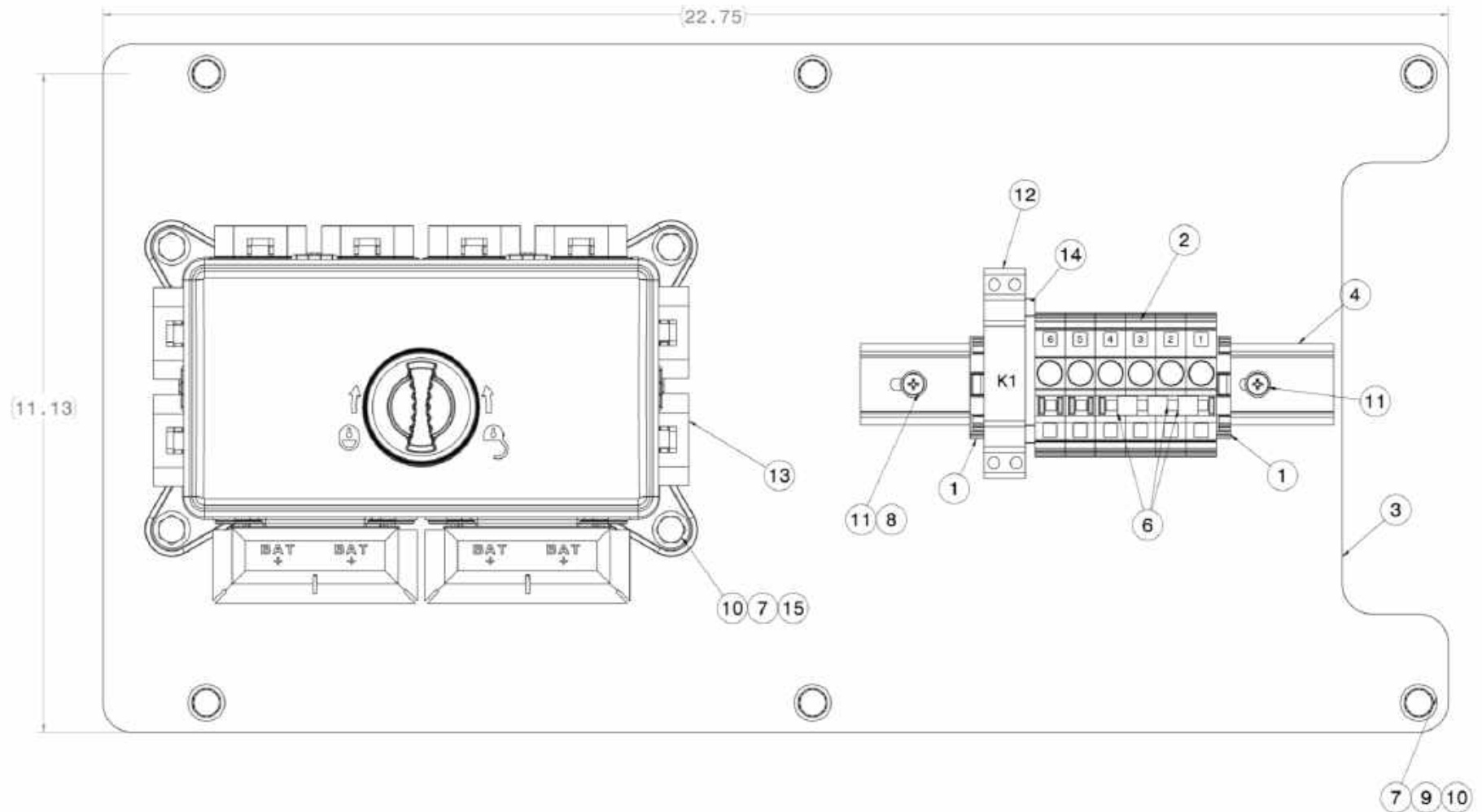

**Parts List**

When ordering replacement parts/kits, please specify model, serial number and color of your unit.

Item	Part Number	Description	Qty
1	13070	ANCHOR DINRAIL END	2
2	EC-2555	TERMINAL, BLOCK FUSE	6
3	S-3073-01	SHELF	1
4	EC-1895-008.00	RAIL, DIN	1
5	G-1439-1035-S	NUTSERT, #10-32 OPEN END	2
6	EC-2948	JUMPER, ADJACENT NOMINAL	3
7	G-1503-1050N	FLATWASHER. 1/4 SST NARROW	14
8	G-1503-1030N	FLATWASHER. #10 SST NARROW	2
9	G-1502-1050R	LOCKWASHER, 1/4 SST REGULAR	6
10	G-1112-105006	BOLT, 1/4-20 X 3/4" LG SST HEX HD	10
11	G-1497-103106	SCREW, #10-24 X 3/4" LG. SST PAN HD CROSS RECESS	2
12	EC-2690	RELAY, TIME DELAY ON	1
13	EC-3073	FUSE, RELAY BOX	1
14	EC-2411	PLATE, END DIODE BLOCK	1
15	G-1202-1050	STOPNUT, 1/4-20 ELASTIC	4

**Parts List Illustration**

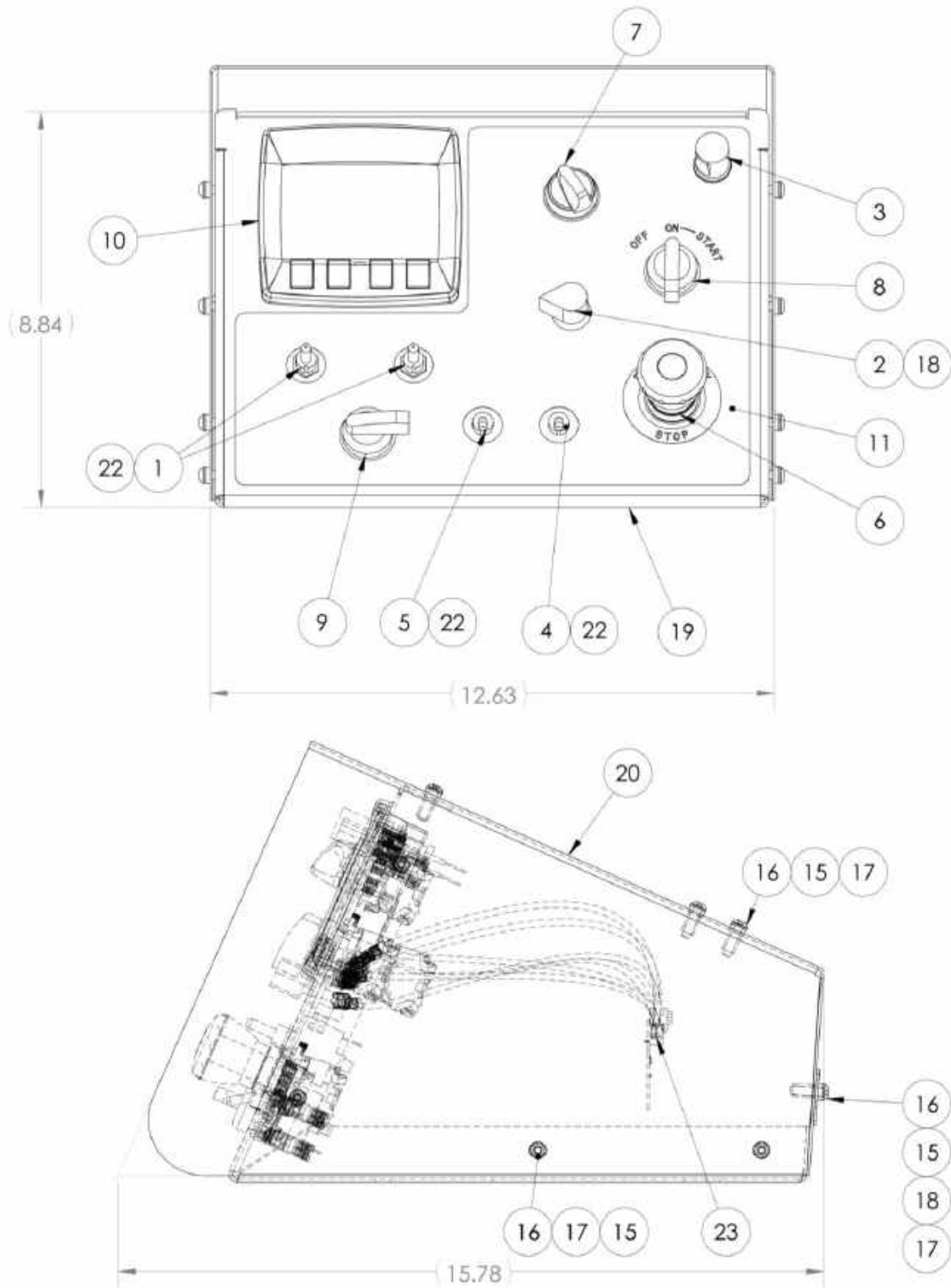

## Parts List

When ordering replacement parts/kits, please specify model, serial number and color of your unit.



Item	Part Number	Description	Qty
1	EC-2745	SWITCH, TOGGLE 3 POS (DPDT)8002K98 - 1/4 QUICK-DISCONNECT	2
2	EC-2931	SWITCH, ROTARY	1
3	ec-2693	LAMP, PANEL LED (WHITE)	1
4	EC-2746	SWITCH, TOGGLE 2 POS (SPST)8002K71 - 1/4" QUICK DISCONNECT	1
5	EC-2747	SWITCH, TOGGLE 2 POS (DPST)8002K77 - 1/4" QUICK DISCONNECT	1
6	14132	SWITCH, EMERGENCY STOP	1
7	14133	SWITCH, IDLR/RUN	1
8	EC-2740	SWITCH, 3 POSITION SPRING R/L	1
9	EC-2741 SWITCH	SWITCH, 3 POS MAINT W/LEVE	1
10	XL00-10-001-CAP	DISPLAY, PROGRAMMED	1
11	V-2687	LABEL, CONTROL PANEL	1
12	14142	FLANGE, LATCH	4
13	14143)	BLOCK, CONTACT (GREEN)	3
14	14144	BLOCK, CONTACT (RED)	5
15	G-1658-04	WASHER W/NEOPRENE #10	17
16	G-1476-103106	SCREW, #10-32 X 3/4" LG. SST SOC BUTT. HD CAP	17
17	G-1439-1035-S	NUTSERT, #10-32 OPEN END	17
18	S-3055-01	PLATE, COVER	1
19	S-3024-01	CONSOLE CENTER BASE	1
20	S-3025-01	CONSOLE, CENTER TOP (P)(R)	1
21	EC-2932	KNOB	1
22	EC-2744	SEAL, TOGGLE SWITCH	4
23	Z-9536	ASSEMBLY, CENTER CONTROL PANEL	1

**Parts List**

When ordering replacement parts/kits, please specify model, serial number and color of your unit.

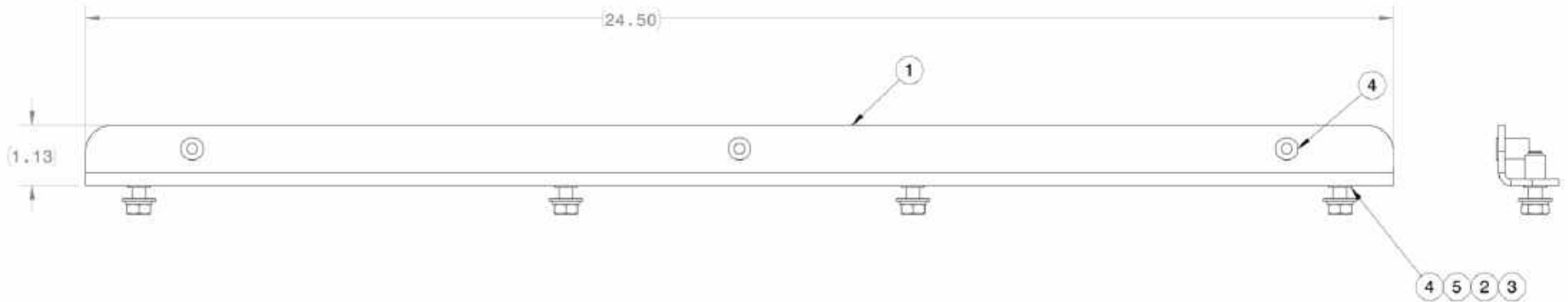

Item	Part Number	Description	Qty
1	S-3043-01	BRACKET, LONG	1
2	G-1503-1050N	FLATWASHER, 1/4 SST NARROW	4
3	G-1502-1050R	LOCKWASHER, 1/4 SST REGULAR	4
4	G-1440-1050-S	NUTSERT, 1/4-20 OPEN END	7
5	G-1112-105010	BOLT, 1/4-20 X 1.0" LG SST HEX HD	4

## Parts List

When ordering replacement parts/kits, please specify model, serial number and color of your unit.

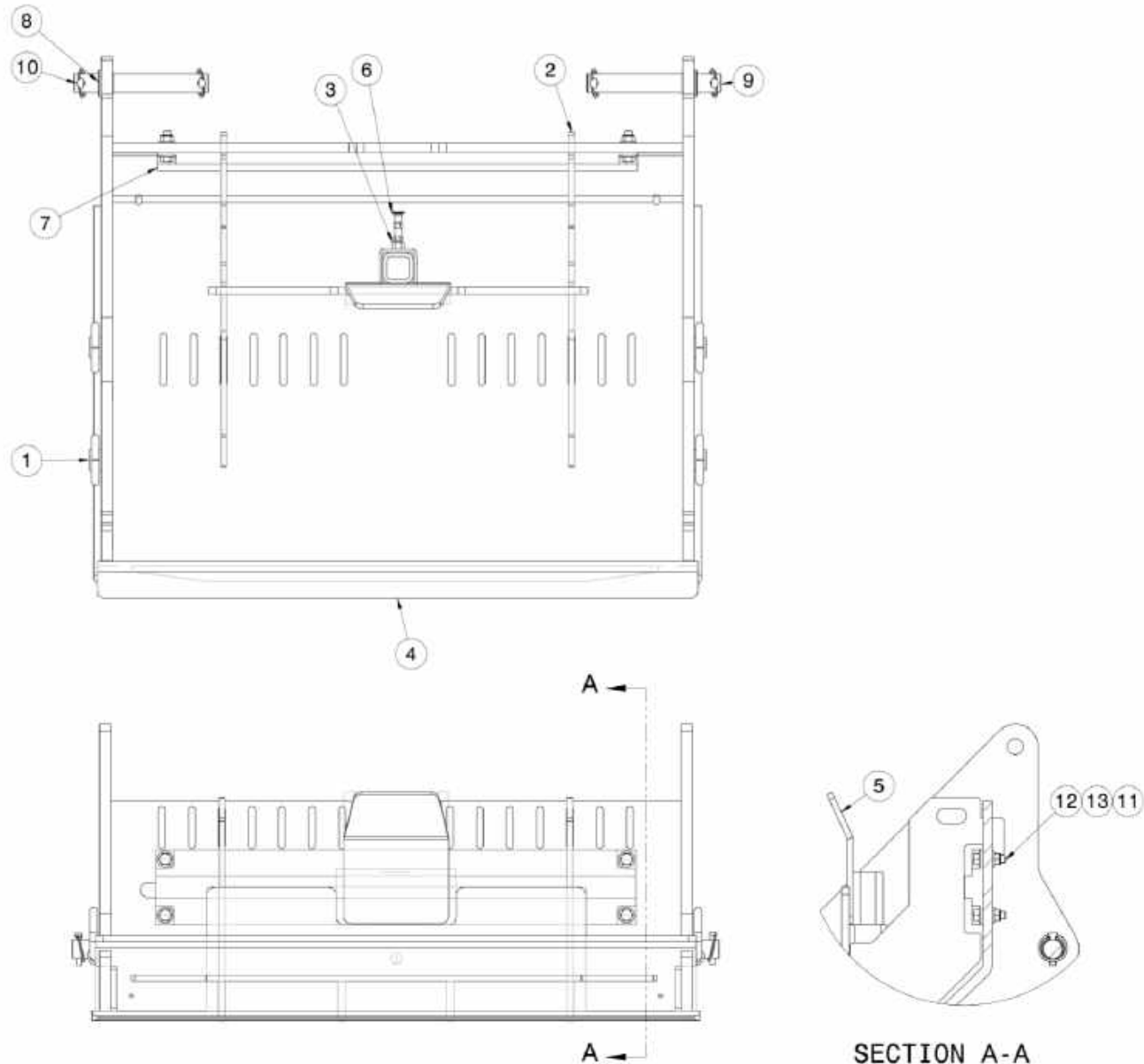

Item	Part Number	Description	Qty
1	Z-9024-01/SP	WELDMENT, CRADLE ASSY	REF
2	J-6283-01/SP	PLATE, MOVABLE SIDE	REF
3	Z-6508-01/SP	WELDMENT, CRADLE PLATE	REF
4	Z-6322-01/SP	WELDMENT, CRADLE ASSY STOP	REF
5	Z-6509-01/SP	WELDMENT, NOSE SHOE	REF
6	JP-115	PLUNGER, INDEXING	1
7	EC-2623	SWITCH, TAPE	1
8	H-3689	BEARING, FLANGE 1-1/4 ID 1-1/2 OD X 1 LG	2
9	R-3002	ROD, CRADLE	2
10	JP-114	LINCH, PIN	4
11	G-1250-1090N	FLATWASHER. 1/2 NARROW	8
12	G-1112-109016	BOLT, 1/2-13 X 1-3/4" SST HEX HD	4
13	G-1202-1090	STOPNUT, 1/2-13 ELASTIC	4

**Parts List**

When ordering replacement parts/kits, please specify model, serial number and color of your unit.

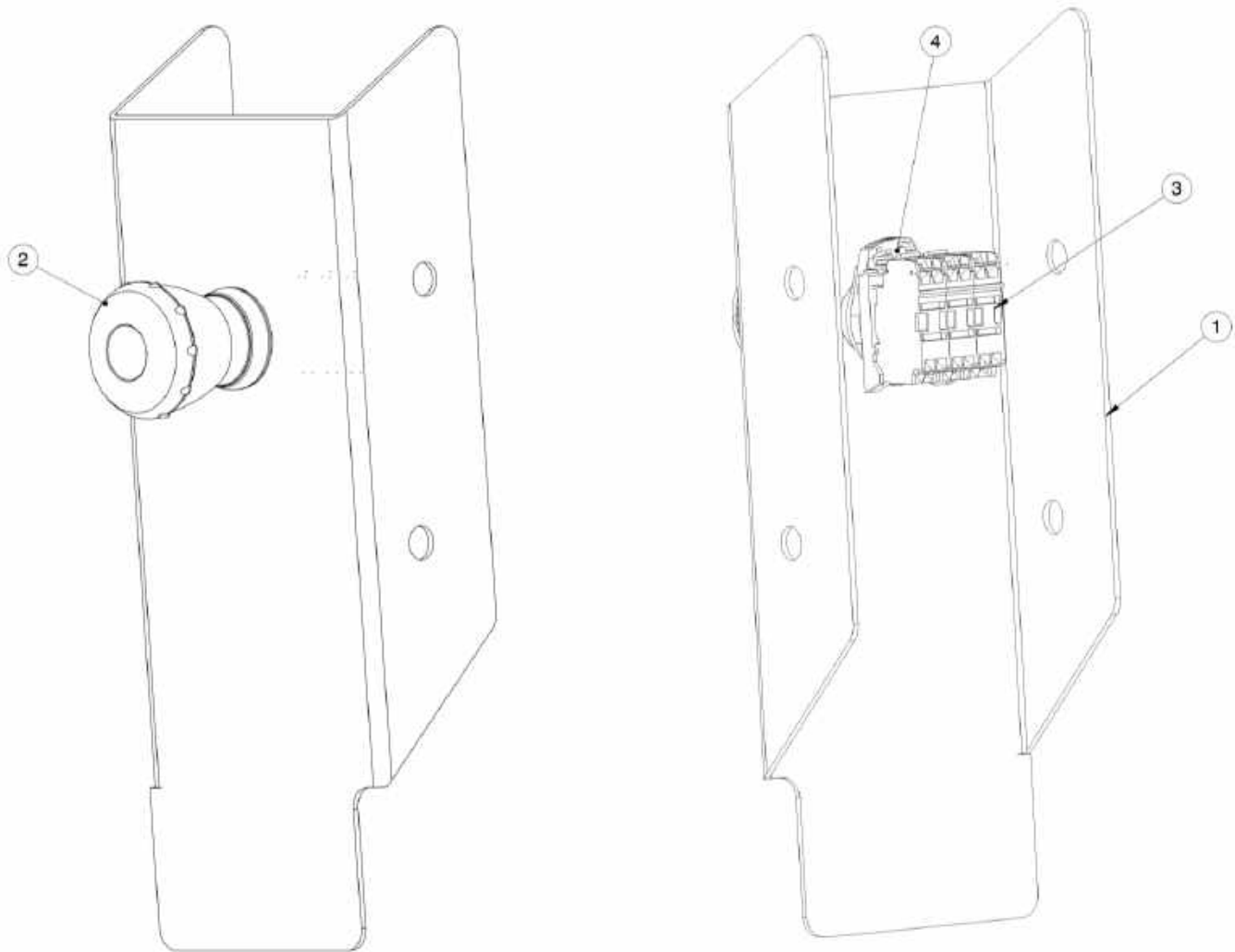

Item	Part Number	Description	Qty
1	S-2874-01	BRACKET, E-STOP	1
2	14132	SWITCH, E-STOP	1
3	14144	BLOCK, CONTACT (RED)	3
4	14142	FLANGE, LATCH	1

**Parts List**

When ordering replacement parts/kits, please specify model, serial number and color of your unit.

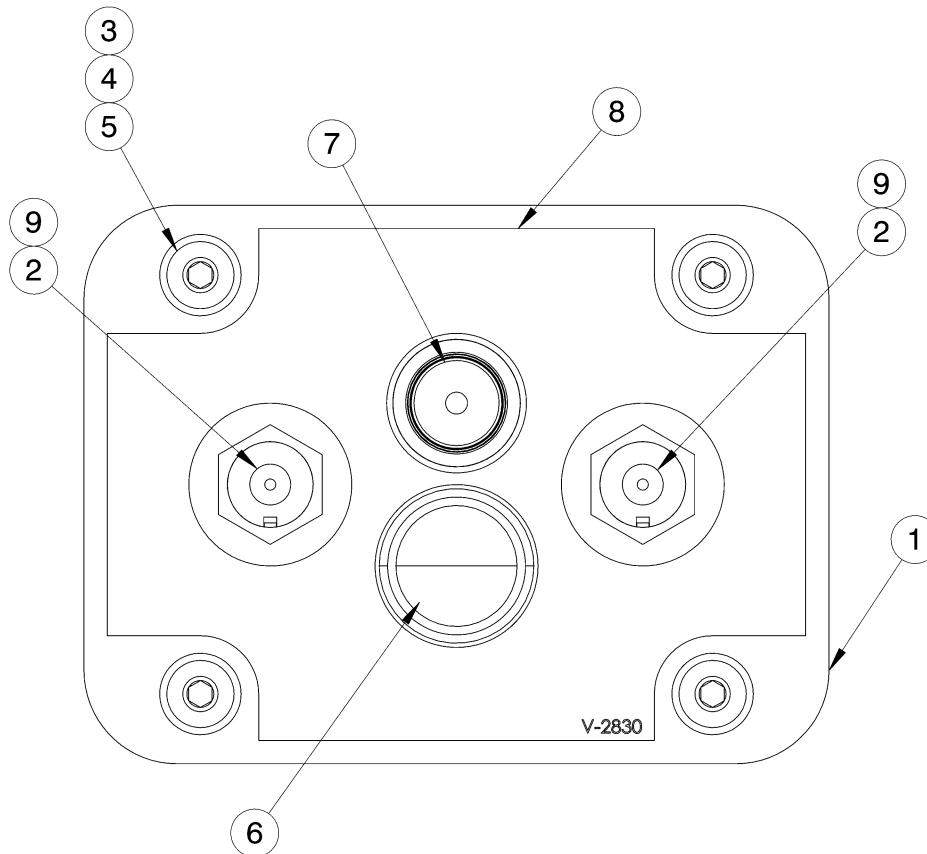

Item	Part Number	Description	Qty
1	S-3860-00	PANEL, SWITCH W/ BRAKE RELEASE	1
2	EC-2745	SWITCH, TOGGLE 3 POS (DPDT)	2
3	G-1503-1030N	FLATWASHER. #10 SST NARROW	4
4	G-1502-1030R	LOCKWASHER, #10 SST REGULAR	4
5	G-1476-103110	SCREW, #10-32 X 1.0" LG. SST SOC BUTT. HD CAP	4
6	EC-2826	LED, PANEL LAMP (GREEN)	1
7	EC-2947	PUSH BUTTON, MOMENTARY	1
8	V-2830	LABEL, FENDER SWITCH	1
9	EC-2744	RUBBER, SWITCH BOOTS	2

**Parts List**

When ordering replacement parts/kits, please specify model, serial number and color of your unit.

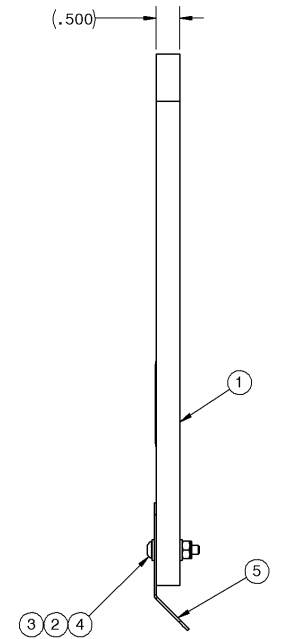
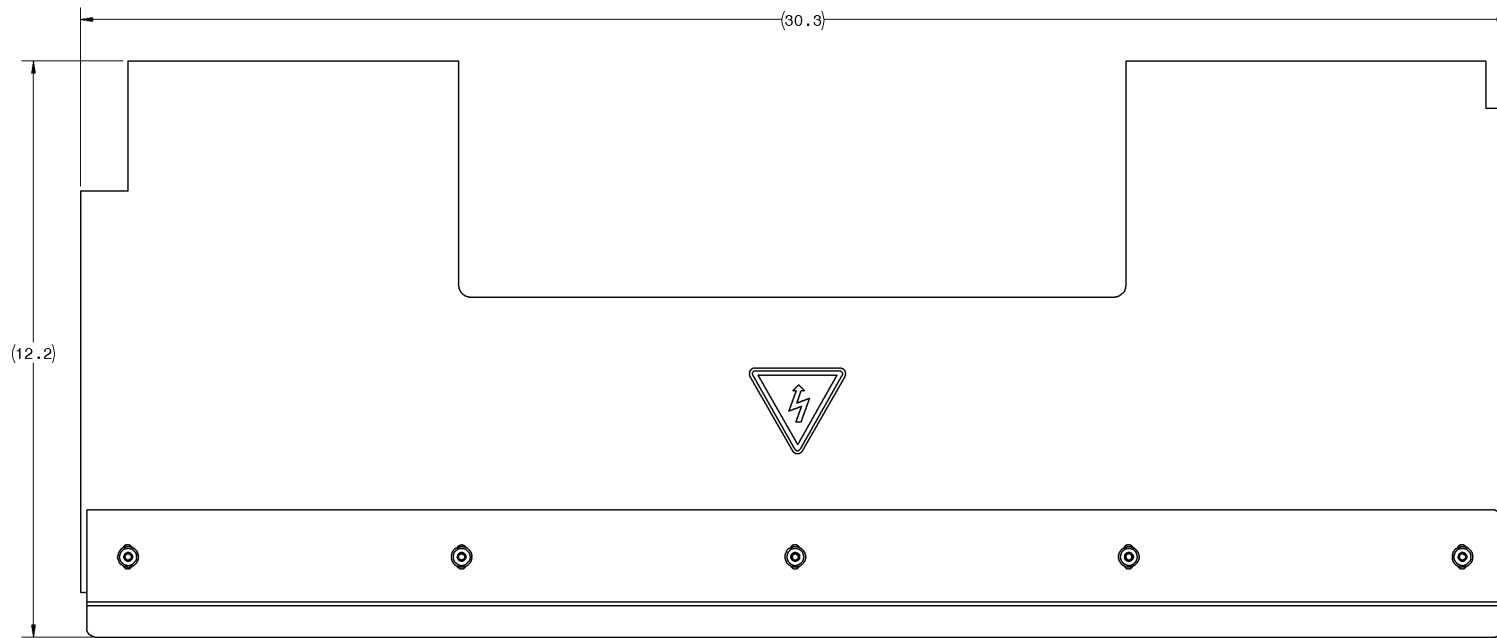

**Parts List**

When ordering replacement parts/kits, please specify model, serial number and color of your unit.

Item	Part Number	Description	Qty
1	J-6534	MACHINE, COVER CONTACT	1
2	G-1503-1030N	FLATWASHER. #10 SST NARROW	10
3	G-1202-1035	STOPNUT, #10-32 ELASTIC	5
4	G-1476-103110	SCREW, #10-32 X 1.0" LG. SST SOC BUTT. HD CAP	5
5	S-2859-00	BRACKET, COVER(P)	1
6	V-1050	LABEL, ISO ELECTRICAL SHOCK	1

**Parts List**

When ordering replacement parts/kits, please specify model, serial number and color of your unit.

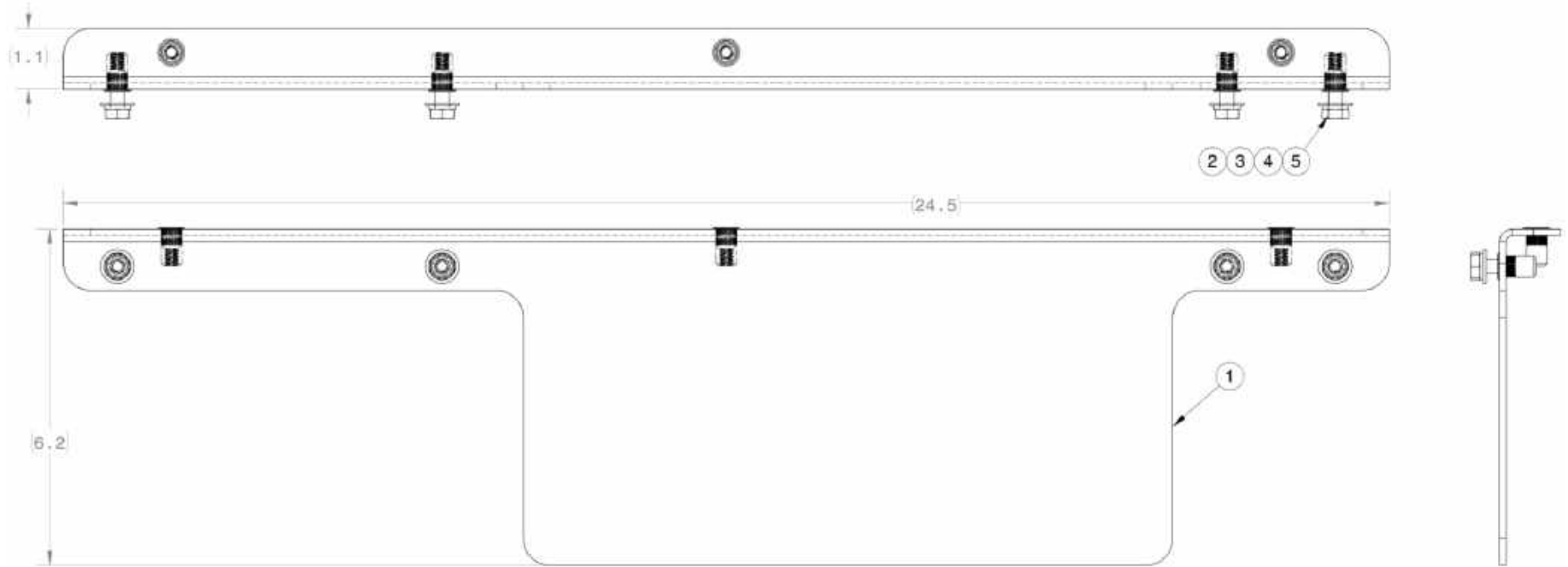

Item	Part Number	Description	Qty
1	S-3189-01	BRACKET, COVER	1
2	G-1440-1050-S	NUTSERT, 1/4-20 OPEN END	7
3	G-1503-1050N	FLATWASHER, 1/4 SST NARROW	4
4	G-1502-1050R	LOCKWASHER, 1/4 SST REGULAR	4
5	G-1112-105010	BOLT, 1/4-20 X 1.0" LG SST HEX HD	4

**Parts List Illustration**

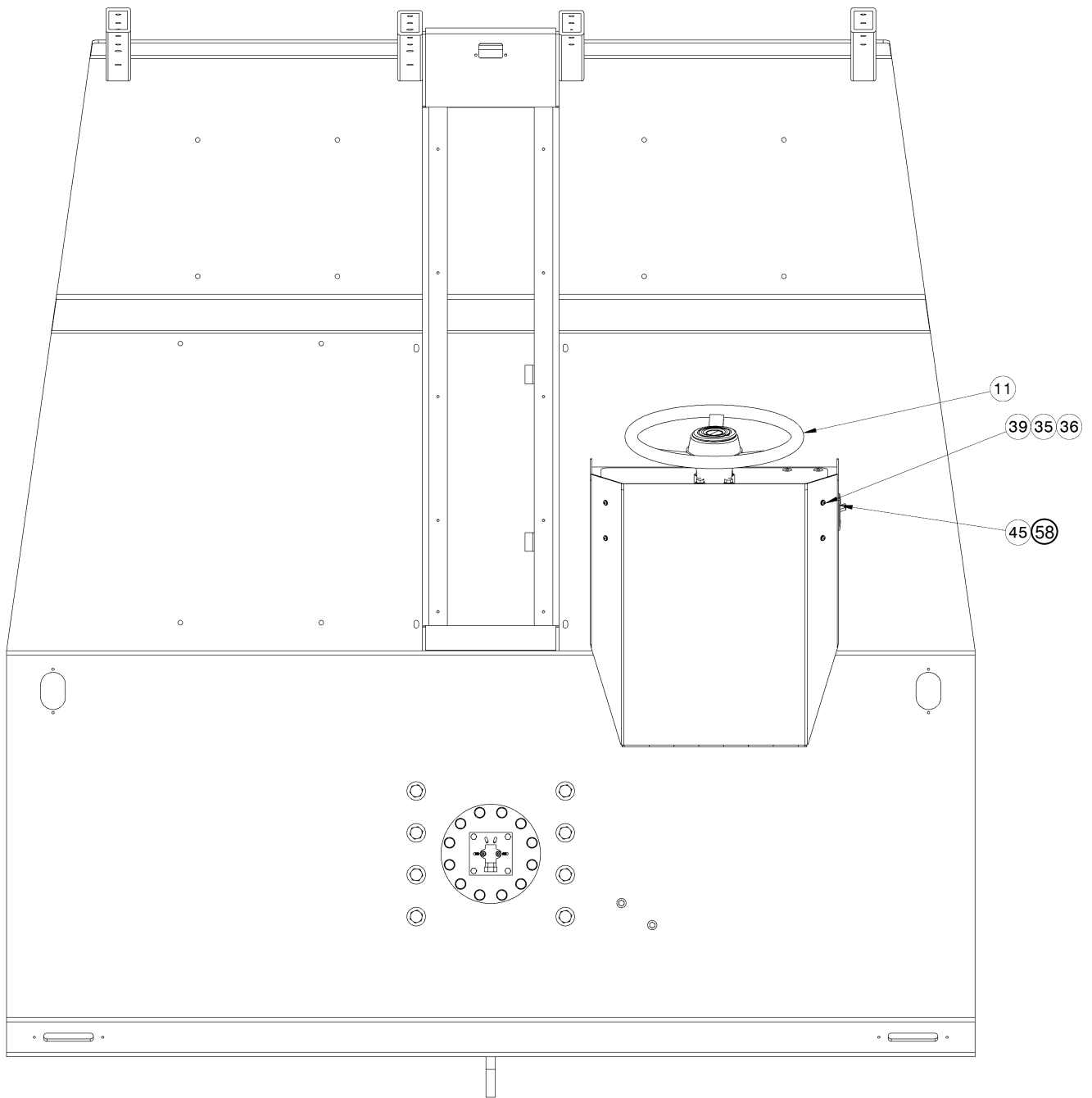

**Parts List Illustration**

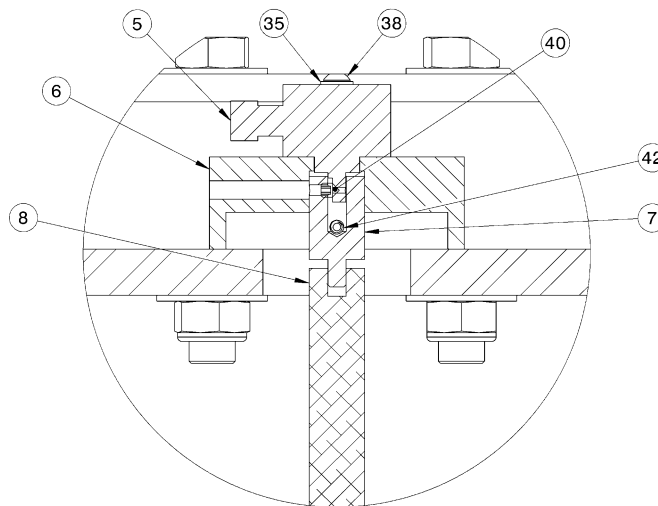

**DETAIL C**  
**SCALE 2 : 3**

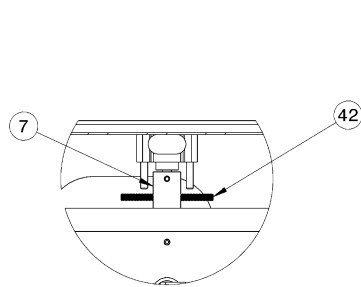

**DETAIL D**  
**SCALE 1 : 3**

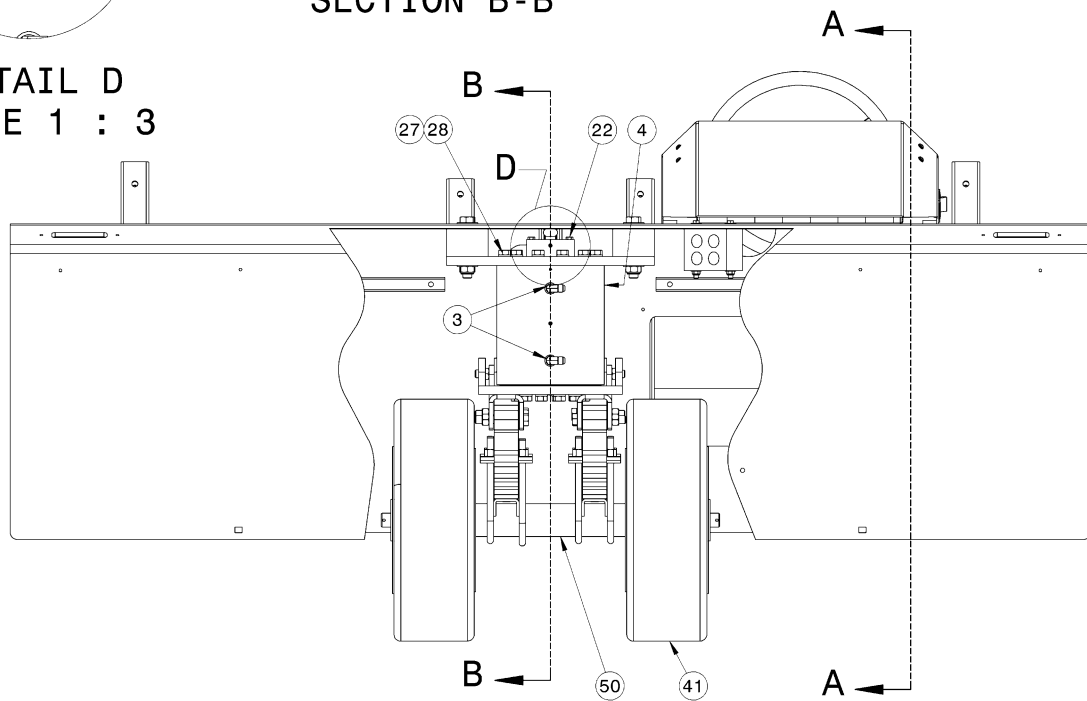
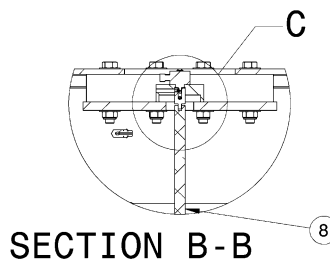

## Parts List Illustration

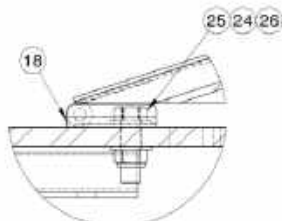
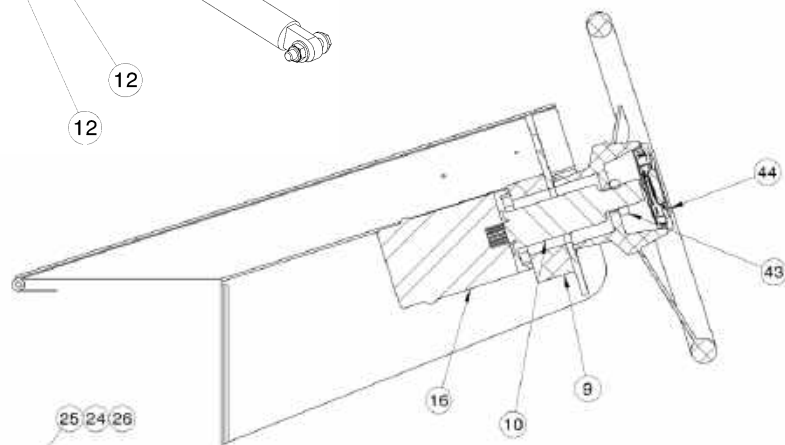
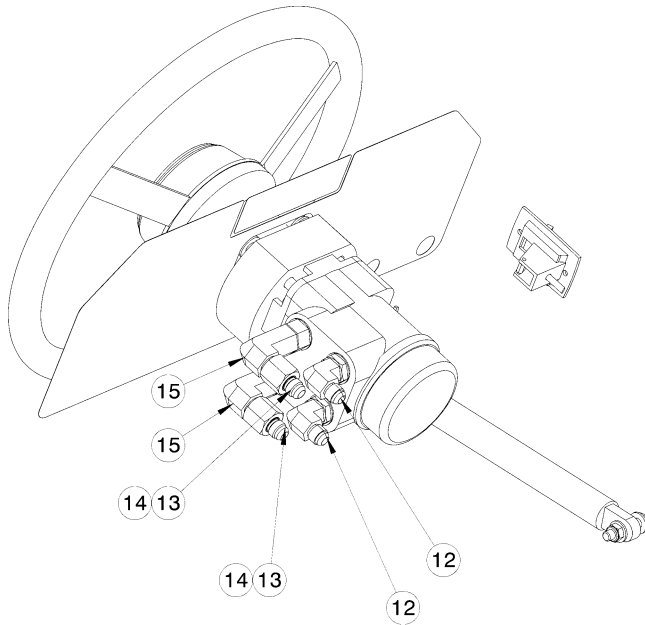

**DETAIL E**  
SCALE 1 : 2

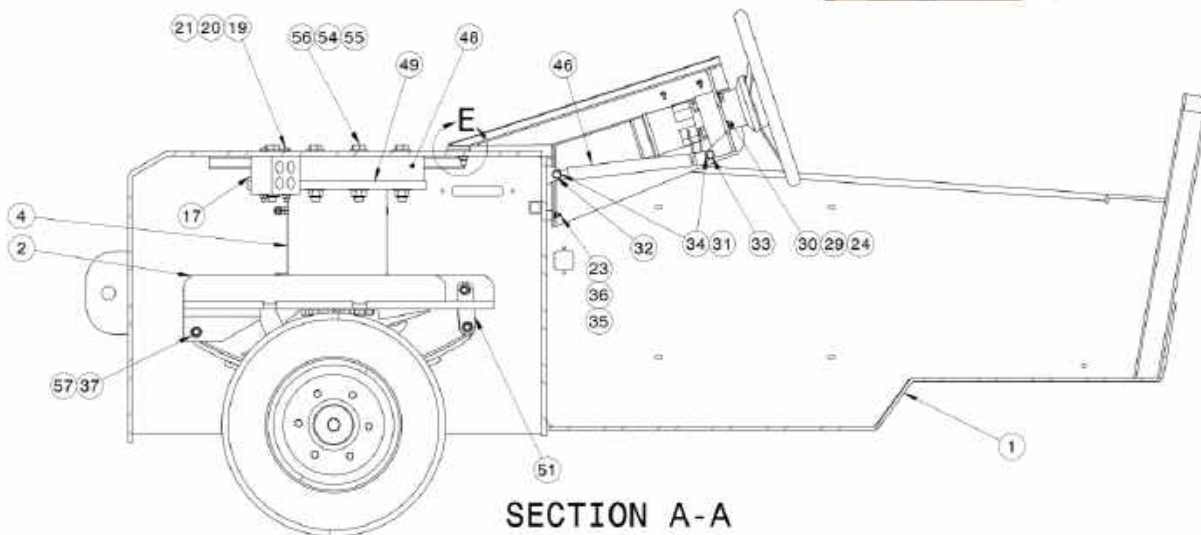

**SECTION A-A**

### Parts List

When ordering replacement parts/kits, please specify model, serial number and color of your unit.

Item	Part Number	Description	Qty
1	Z-9474 P3	SUBFRAME, STEERING	REF
2	Z-9471-00	WELDMENT, STEER PLATE	REF
3	N-2001-35-S-B	ELBOW, STRAIGHT THREAD (6-4)	2
4	HC-2870	ACTUATOR, ROTARY	1
5	EC-2996	SENSOR, ROTARY HALL EFFECT	1
6	J-6536	PLATE, SENSOR ARM	1
7	R-3141	EXTENSION, ROD	1
8	R-3136	EXTENSION, ROD	1
9	R-2319	SPACER, STEERING	1
10	H-3067	STEERING, COLUMN	1
11	H-3068	STEERING, WHEEL	1
12	N-2001-09-S-B	ELBOW, STRAIGHT THREAD	2
13	N-2020-03-S	REDUCER, TUBE END	2
14	N-2000-06-S	NUT, #8 JIC X 37 DEG	2
15	N-2706-03-S-B	ELBOW, LONG STR THD	2
16	HC-2789	STEERING VALVE (P)	1
17	J-6387	BLOCK, HOSE ROUTING	1
18	S-2695-01	HINGE, SPACER	1
19	G-1420-106040	BOLT, 5/16-18 X 4" LG. HEX HD GR 8	2
20	G-1503-1060N	FLATWASHER, 5/16 NARROW S.S.	4
21	G-1202-1060	STOPNUT, 5/16-18 ELASTIC	2
22	G-1100-105514	BOLT, 1/4-28 X 1-1/2" LG HEX HD GR 5	4
23	JP-242	BUMPER GUARDS, STEER COWL	2
24	G-1250-1070N	FLATWASHER. 3/8 NARROW	9
25	G-1100-107012	BOLT, 3/8-16 X 1-1/4" HEX HD GR 5	2
26	G-1202-1070	STOPNUT, 3/8-16 ELASTIC	2
27	G-1251-1090R	LOCKWASHER, 1/2 REGULAR	24
28	G-1100-109014	BOLT, 1/2-13 X 1-1/2" HEX HD GR 5	24
29	G-1251-1070R	LOCKWASHER, 3/8 REGULAR	4
30	G-1100-107030	BOLT, 3/8-16 X 3.0" HEX HD GR 5	4
31	G-1250-1060N	FLATWASHER. 5/16 NARROW	4
32	G-1100-106514	BOLT, 5/16-24 X 1-1/2" LG. HEX HD GR 5	1
33	G-1100-106520	BOLT, 5/16-24 X 2" LG. HEX HD GR 5	1
34	G-1202-1065	STOPNUT, 5/16-24 ELASTIC	2
35	G-1503-1030N	FLATWASHER. #10 SST NARROW	8
36	G-1202-1035	STOPNUT, #10-32 ELASTIC	6
37	G-1240	NUT, SHACKLE	6
38	G-1476-103116	SCREW, #10-32 X 1-3/4" LG. SST SOC BUTT. HD CAP	2
39	G-1497-103106	SCREW, #10-24 X 3/4" LG. SST PAN HD CROSS RECESS	4
40	G-1698	SCREW, HEX DRIVE CONE POINT	1
41	U-1175	TIRE, 18X7-8 ON 8 IN. WHEEL	2
42	H-4116	BIT, #2 PHILLIPS	2
43	H-3069	WHEEL, NUT	1

### Parts List

When ordering replacement parts/kits, please specify model, serial number and color of your unit.

Item	Part Number	Description	Qty
44	EC-2040	HORN, BUTTON	1
45	JP-271	STEERING COWEL LIFT LEVER	1
46	H-3665	CYLINDER, BLOCK - A - LIFT	1
47	V-2247	LABEL, DRIVING OPERATION	1
48	J-4358	SPACER, STEERING PLATE	2
49	J-7526-00	PLATE, UPPER STEERING	1
50	Z-9446	ASSEMBLY, STEERING	1
51	J-6509-00	LINK, AXLE	4
52	Z-9272-00	WELDMENT, STEERING COWL	1
53	V-2674	LABEL, DASH PANEL TRONAIR	1
54	G-1503-1100N	FLATWASHER. 5/8 SST NARROW	16
55	G-1202-1105	STOPNUT, 5/8-18 ELASTIC	8
56	G-1420-110540	BOLT, 5/8-18 X 4.0" HEX HD GR 8	8
57	G-1420-121534	BOLT, 9/16-18 HEX HD GR 8	6
58	G-1152-103703	Screw, 10 – 32 x 3/8 LG	4

**Parts List Illustration**

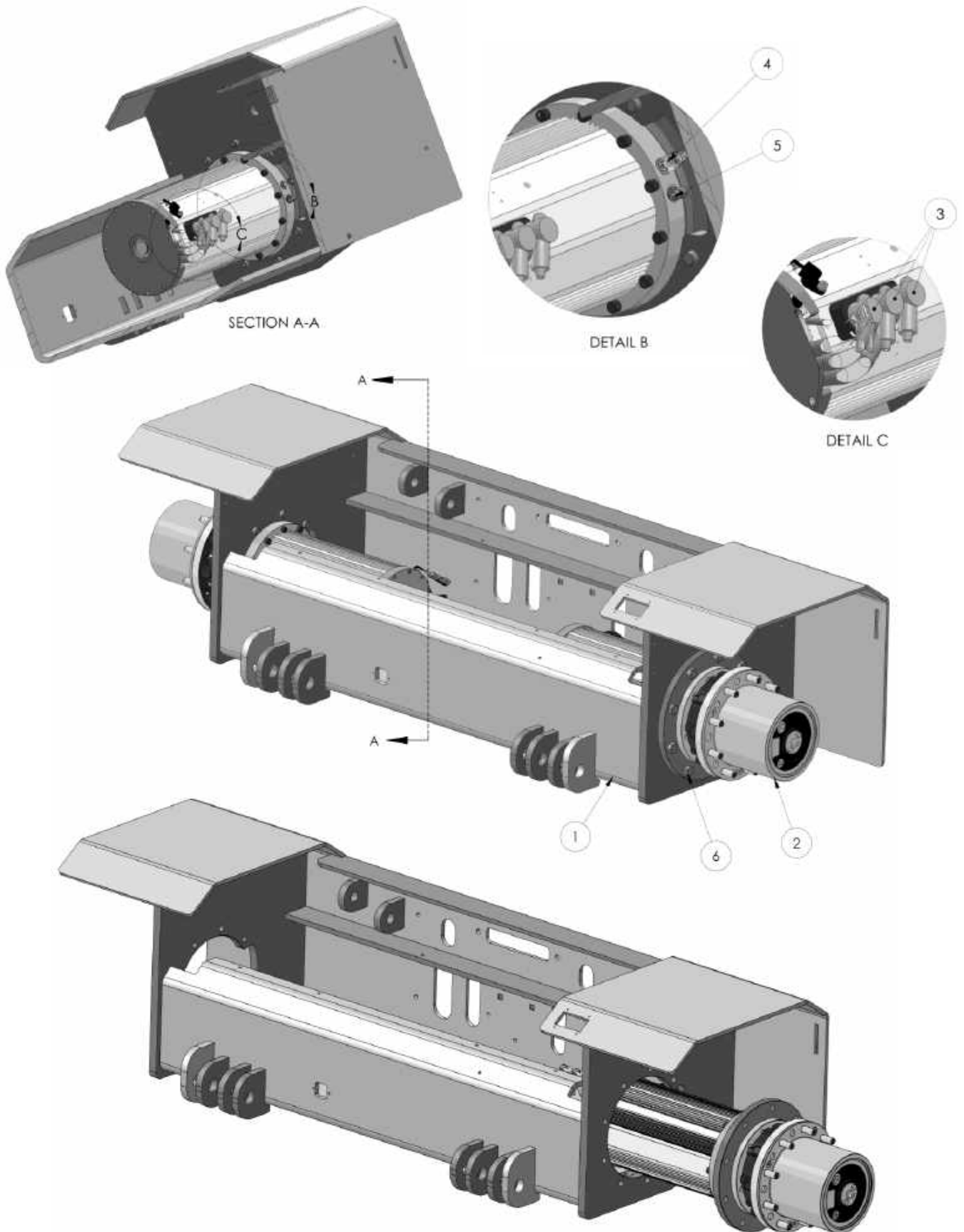

**Parts List**

When ordering replacement parts/kits, please specify model, serial number and color of your unit.

Item	Part Number	Description	Qty
1	Z-9474 P1	WELDMENT, CRADLE PIVOT	REF
2	EC-3072	MOTOR, AC VEHICLE	2
3	EC-2110	BATTERY, TERMINAL INSULATOR	6
4	N-3027	PORT, BLEED ADAPTER	2
5	N-2001-03-S-B	ELBOW, STRAIGHT THREAD	2
6	G-1420-110520	BOLT, 5/8-18 X 2" HEX HD GR 8	16

**Parts List Illustration**

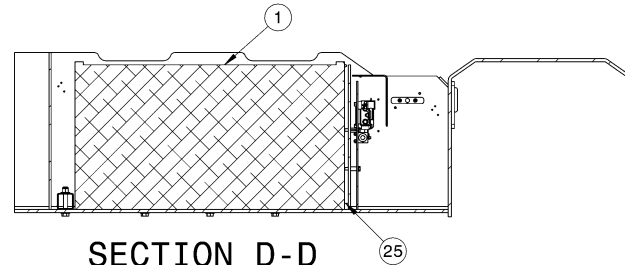

**SECTION D-D**  
**SCALE 5 : 64**

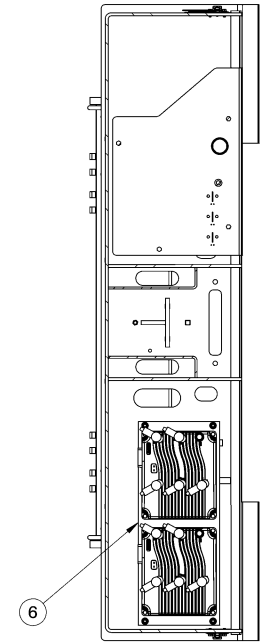
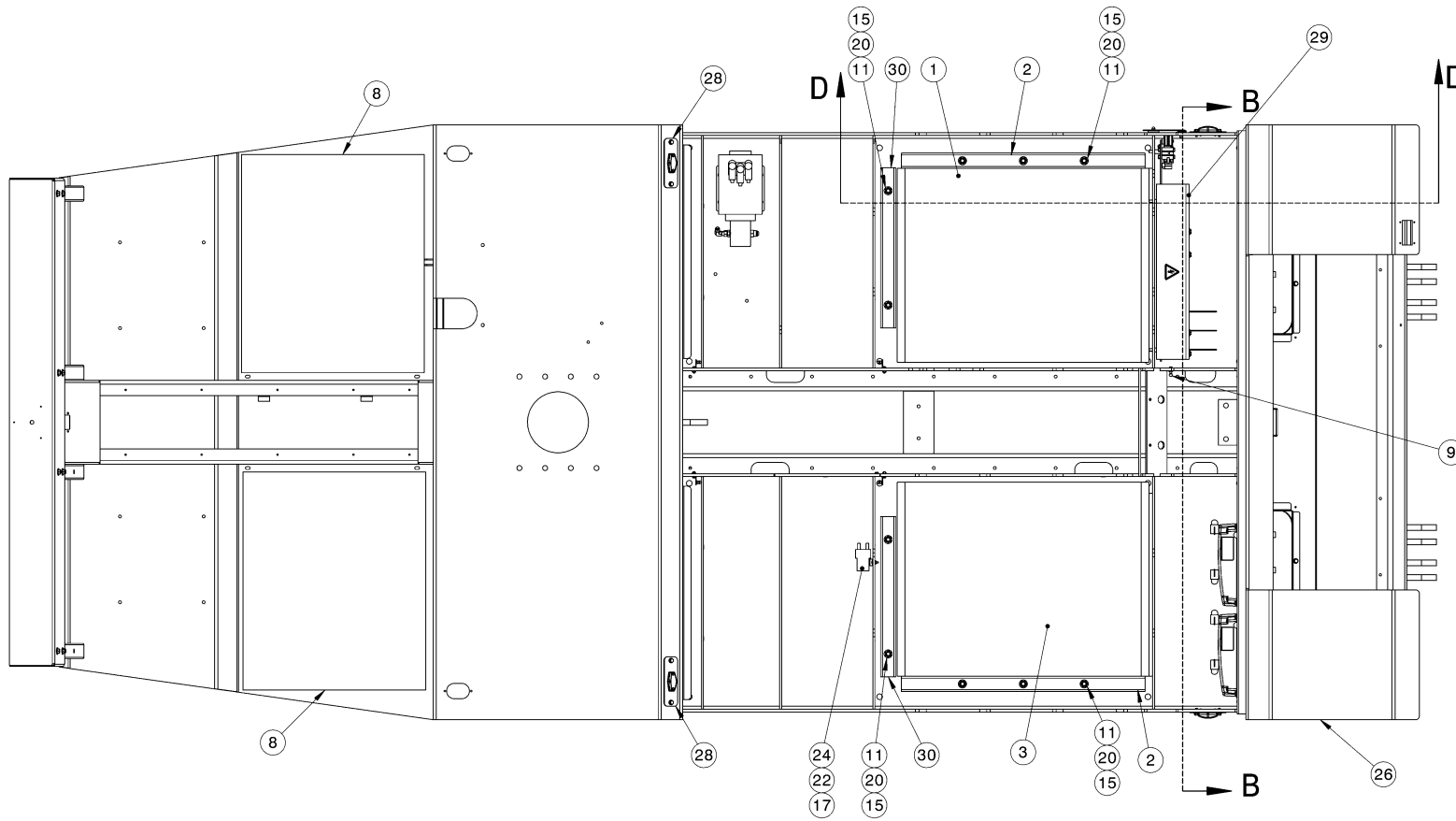

**SECTION B-B**  
**SCALE 5 : 64**

**Parts List Illustration**

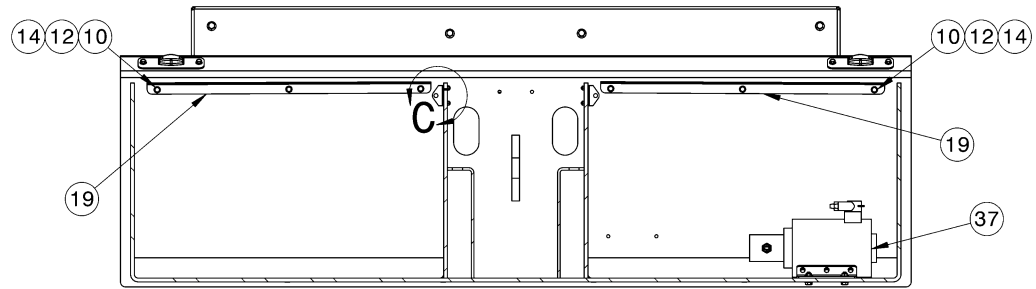
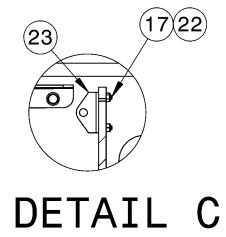
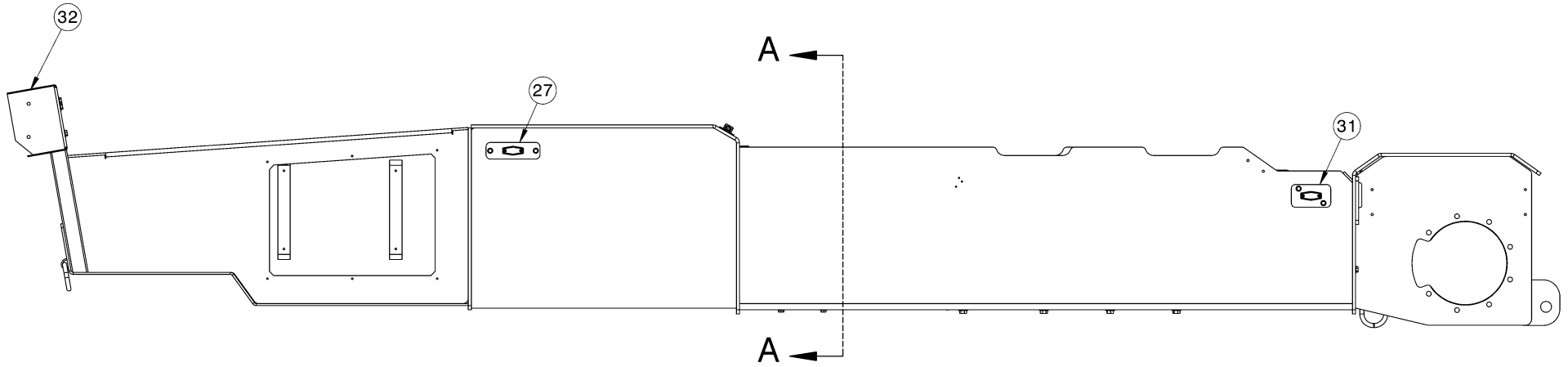

**SECTION A-A**

**Parts List Illustration**

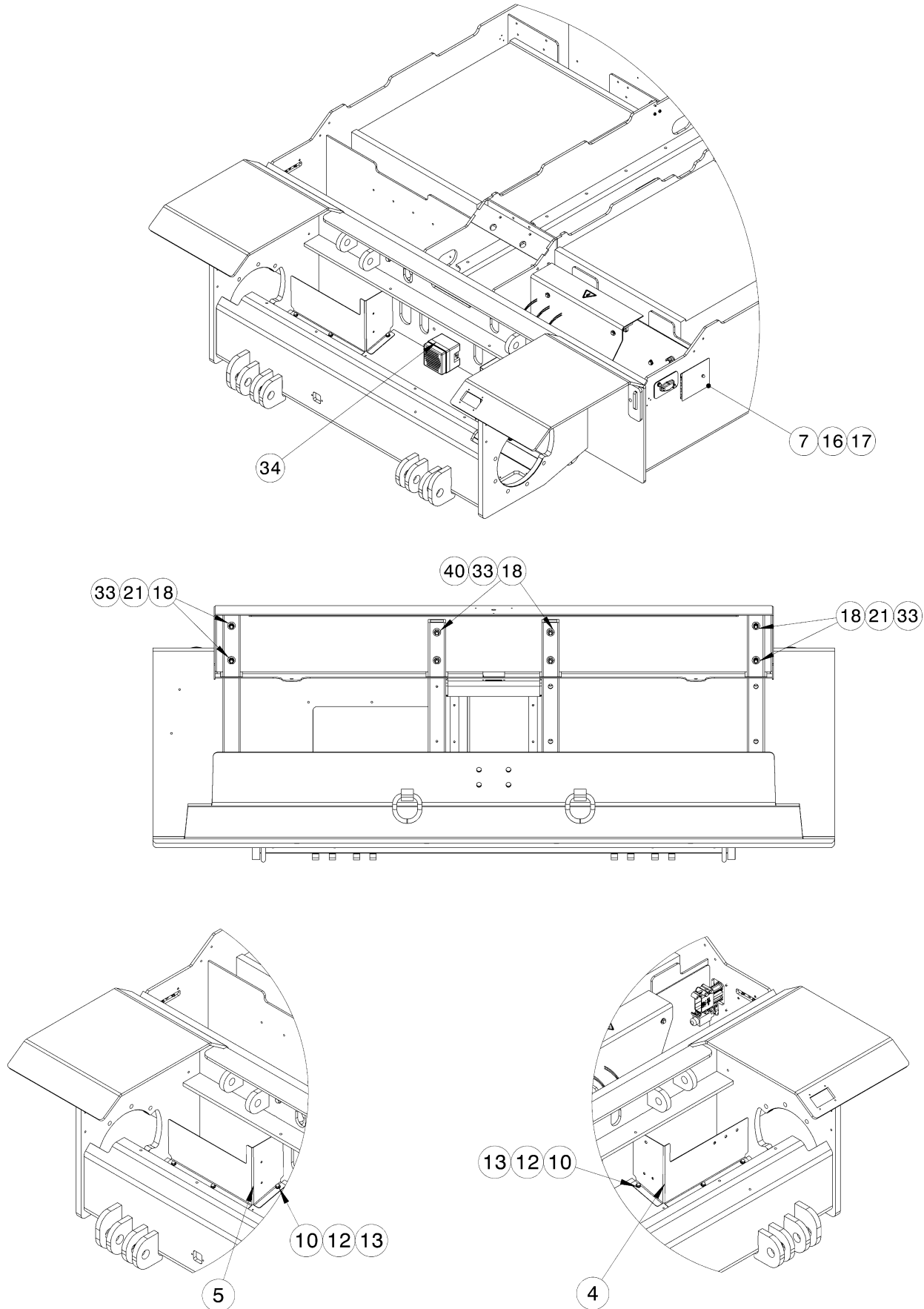

### Parts List

When ordering replacement parts/kits, please specify model, serial number and color of your unit.

Item	Part Number	Description	Qty
1	EC-3091-02	BATTERY, 36V 440 AH eJP-12	1
2	TS-2589-01	TUBE, BATTERY STOP (P)	2
3	EC-3091-01	BATTERY, 36V 440AH eJP-12	1
4	S-2876-01	GUARD, WEATHER LEFT	1
5	S-2875-01	GUARD, WEATHER RIGHT (P)	1
6	Z-9629	ASSEMBLY, CONTROLLER	1
7	Z-8888	ASSEMBLY, CHARGER DOOR	1
8	H-3878	MAT, PLATFORM	2
9	H-3057	BALL, STUD	1
10	G-1250-1050N	FLATWASHER. 1/4 NARROW	12
11	G-1250-1090N	FLATWASHER. 1/2 NARROW	20
12	G-1251-1050R	LOCKWASHER, 1/4 REGULAR	12
13	G-1100-105006	BOLT, 1/4-20 X 3/4" LG HEX HD GR 5	6
14	G-1100-105010	BOLT, 1/4-20 X 1.0" LG HEX HD GR 5	6
15	G-1100-109032	BOLT, 1/2-13 X 3-1/4" HEX HD GR 5	10
16	G-1502-1030R	LOCKWASHER, #10 SST REGULAR	2
17	G-1476-103106	SCREW, #10-32 X 3/4" LG. SST SOC BUTT. HD CAP	12
18	G-1503-1070N	FLATWASHER. 3/8 SST NARROW	16
19	J-6175-01	SUPPORT, GUARD	2
20	G-1202-1090	STOPNUT, 1/2-13 ELASTIC	10
21	G-1202-1070	STOPNUT, 3/8-16 ELASTIC	2
22	G-1202-1035	STOPNUT, #10-32 ELASTIC	10
23	JP-236	BRACKET	4
24	EC-2965	CONTACTOR	1
25	J-6410	SPACER, BATTERY	2
26	Z-9474-00	WELDMENT, FRAME eJP-12 (P)	-1
27	Z-9264	ASSEMBLY, LED RED MARKER	2
28	Z-9265	ASSEMBLY, LED AMBER MARKER	2
29	Z-9491	ASSEMBLY, CONTACTOR PANEL	1
30	TS-2713-01	TUBE, BATTERY STOP	2
31	Z-9503	ASSEMBLY, LED AMBER MARKER	2
32	Z-9297-00	WELDMENT, BACKREST (P)	1
33	G-1112-107030	BOLT, 3/8-16 X 3.0" SST HEX HD	8
34	A-RTT12-00052	ELECTRICAL HORN	1
35	G-1207-1070	NUT, 3/8-16 JAM	6
36	EC-3090	KIT, POWER CABLES eJP-12	1
37	Z-9820	ASSEMBLY, HYD PUMP	1

## Parts List

When ordering replacement parts/kits, please specify model, serial number and color of your unit.

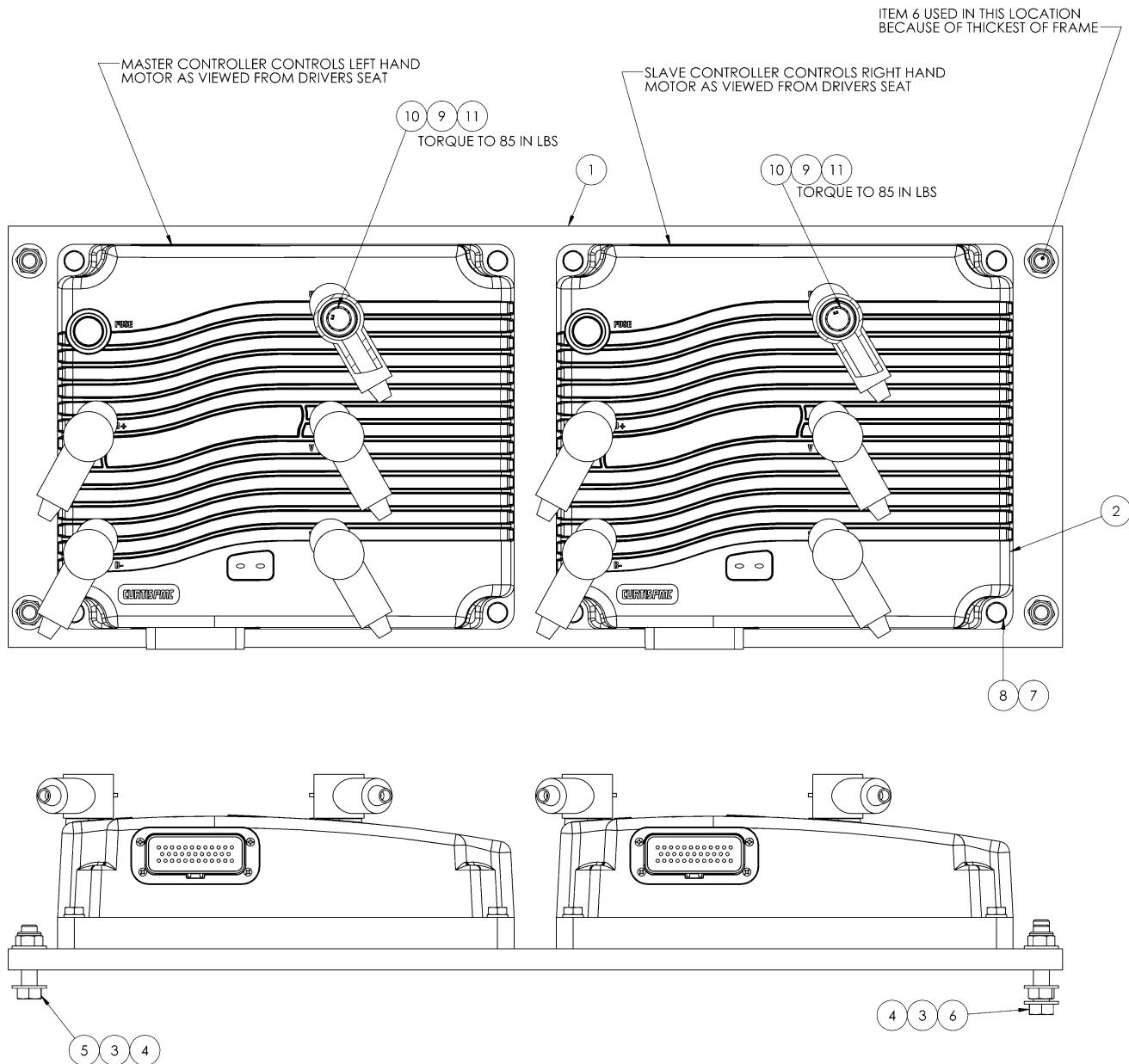

Item	Part Number	Description	Qty
1	J-6018	PANEL, HEAT SINK	1
2	EC-2877	CONTROLLER, AC MOTOR	2
3	G-1250-1070N	FLATWASHER. 3/8 NARROW	8
4	G-1202-1070	STOPNUT, 3/8-16 ELASTIC	4
5	G-1100-107014	BOLT, 3/8-16 X 1-1/2" HEX HD GR 5	3
6	G-1100-107020	BOLT, 3/8-16 X 2.0" HEX HD GR 5	1
7	G-1251-1050R	LOCKWASHER, 1/4 REGULAR	8
8	G-1420-105012	BOLT, 1/4-20 X 1-1/4" LG HEX HD GR 8	8
9	G-1251-1060R	LOCKWASHER, 5/16 REGULAR	10
10	G-1114-080016	BOLT M8-1.25 X 16mm LG. CLASS 8.8	10
11	EC-2110	BATTERY, TERMINAL INSULATOR	10

**Parts List**

When ordering replacement parts/kits, please specify model, serial number and color of your unit.

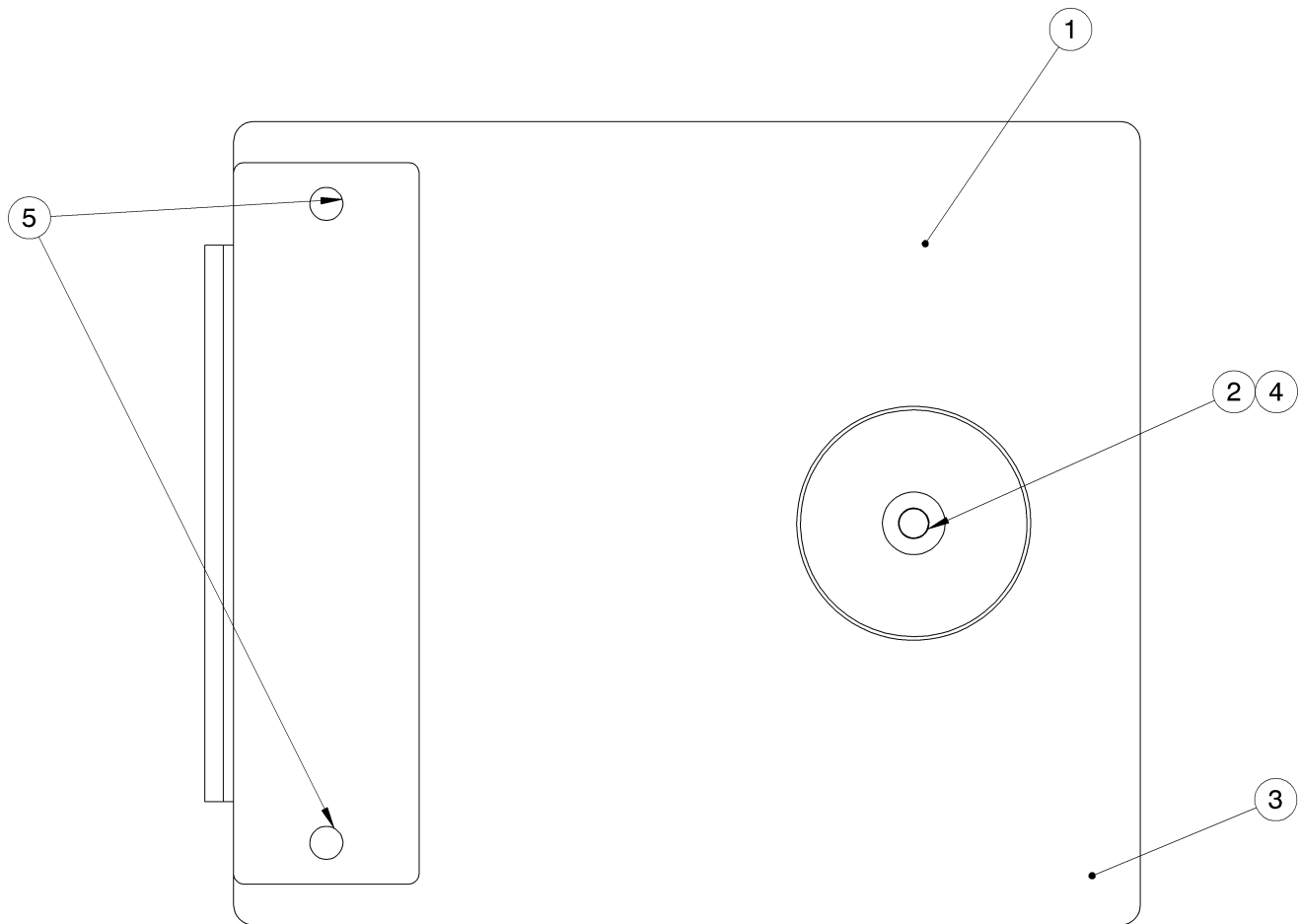

Item	Part Number	Description	Qty
1	Z-8887	WELDMENT, CHARGER DOOR	1
2	H-2882	MAGNET, ENCASED CERAMIC	1
3	H-3191*015.00	TAPE, NEOPRENE FOAM SEAL	1
4	G-1351-18-SS	RIVET, 3/16 OPEN END S.S.	1
5	G-1476-103106	SCR, #10-32 SOC BUT HD CAP	1

**Parts List**

When ordering replacement parts/kits, please specify model, serial number and color of your unit.

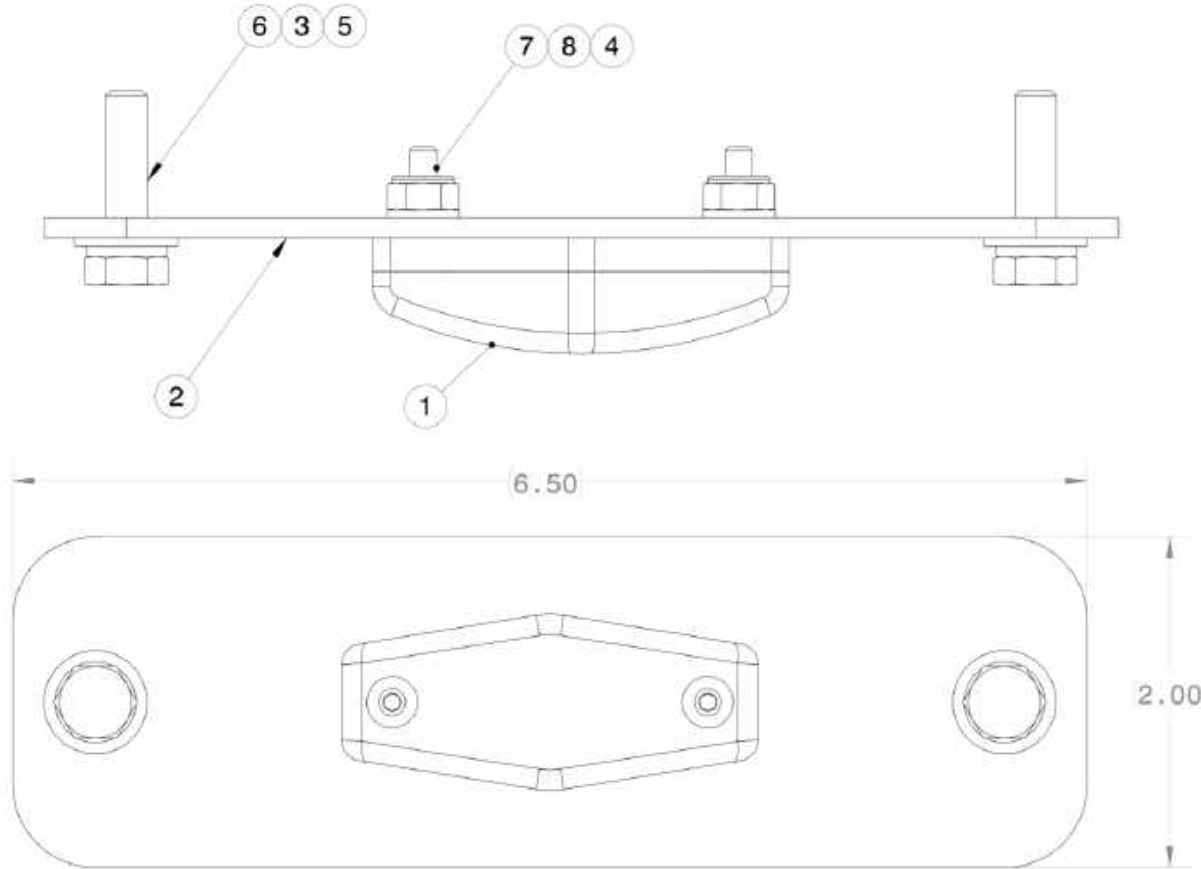

Item	Part Number	Description	Qty
1	NVSP-34-001-CA	SIDE INDICATOR LIGHT, RED	1
2	S-3052-00	PANEL, MARKER	1
3	G-1503-1050N	FLATWASHER, 1/4 SST NARROW	2
4	G-1503-1020N	FLATWASHER, #8 SST NARROW	2
5	G-1502-1050R	LOCKWASHER, 1/4 SST REGULAR	2
6	G-1112-105010	BOLT, 1/4-20 X 1.0" LG SST HEX HD	2
7	G-1476-102006	SCREW, #8-32 X 3/4" LG. SST SOC BUTT. HD CAP	2
8	G-1202-1020	STOPNUT, #8-32 ELASTIC	2

**Parts List**

When ordering replacement parts/kits, please specify model, serial number and color of your unit.

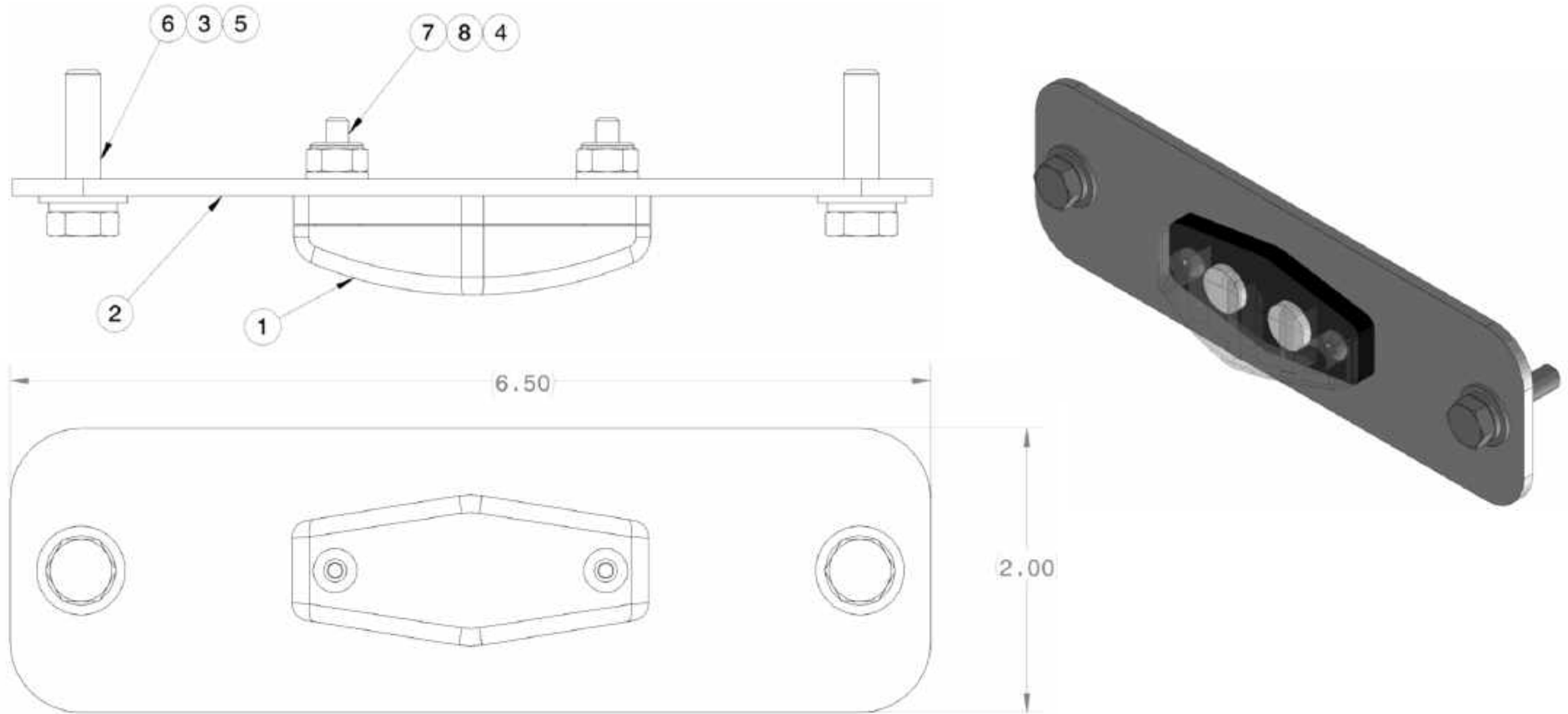

Item	Part Number	Description	Qty
1	A-EXL16-0490-1	SIDE INDICATOR LIGHT, AMBER	1
2	S-3052-00	PANEL, MARKER	1
3	G-1503-1050N	FLATWASHER. 1/4 SST NARROW	2
4	G-1503-1020N	FLATWASHER. #8 SST NARROW	2
5	G-1502-1050R	LOCKWASHER, 1/4 SST REGULAR	2
6	G-1112-105010	BOLT, 1/4-20 X 1.0" LG SST HEX HD	2
7	G-1476-102006	SCREW, #8-32 X 3/4" LG. SST SOC BUTT. HD CAP	2
8	G-1202-1020	STOPNUT, #8-32 ELASTIC	2

**Parts List**

When ordering replacement parts/kits, please specify model, serial number and color of your unit.

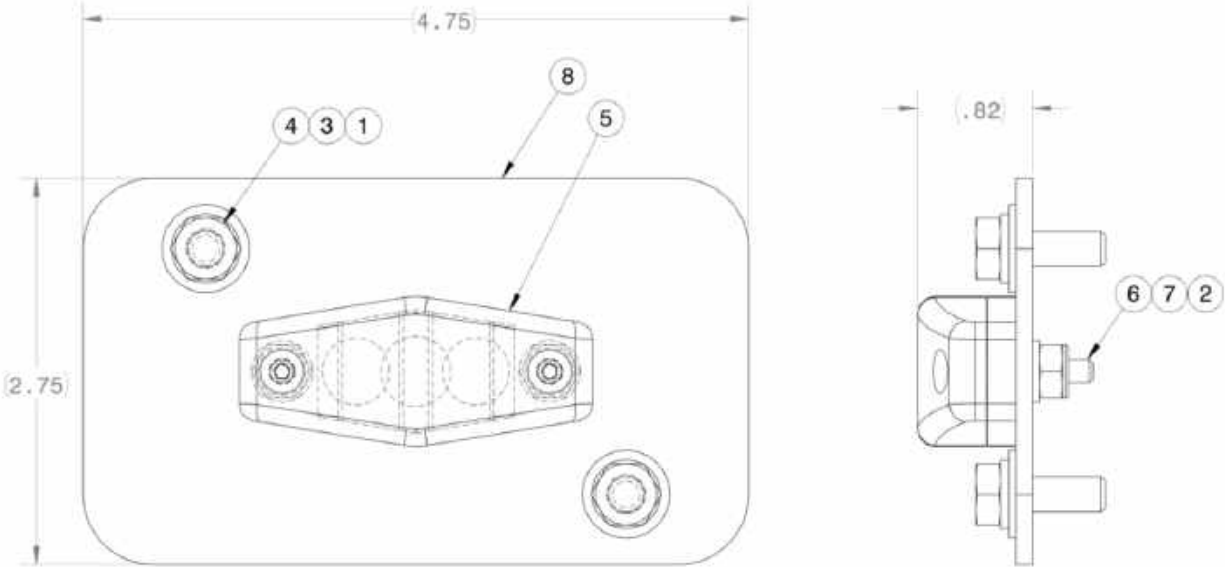

Item	Part Number	Description	Qty
1	G-1503-1050N	FLATWASHER. 1/4 SST NARROW	2
2	G-1503-1020N	FLATWASHER. #8 SST NARROW	2
3	G-1502-1050R	LOCKWASHER, 1/4 SST REGULAR	2
4	G-1112-105006	BOLT, 1/4-20 X 3/4" LG SST HEX HD	2
5	A-EXL16-0490-1	SIDE INDICATOR LIGHT, AMBER	1
6	G-1476-102006	SCREW, #8-32 X 3/4" LG. SST SOC BUTT. HD CAP	2
7	G-1202-1020	STOPNUT, #8-32 ELASTIC	2
8	S-3190-00	PANEL, MARKER (P)	1

**Parts List**

When ordering replacement parts/kits, please specify model, serial number and color of your unit.

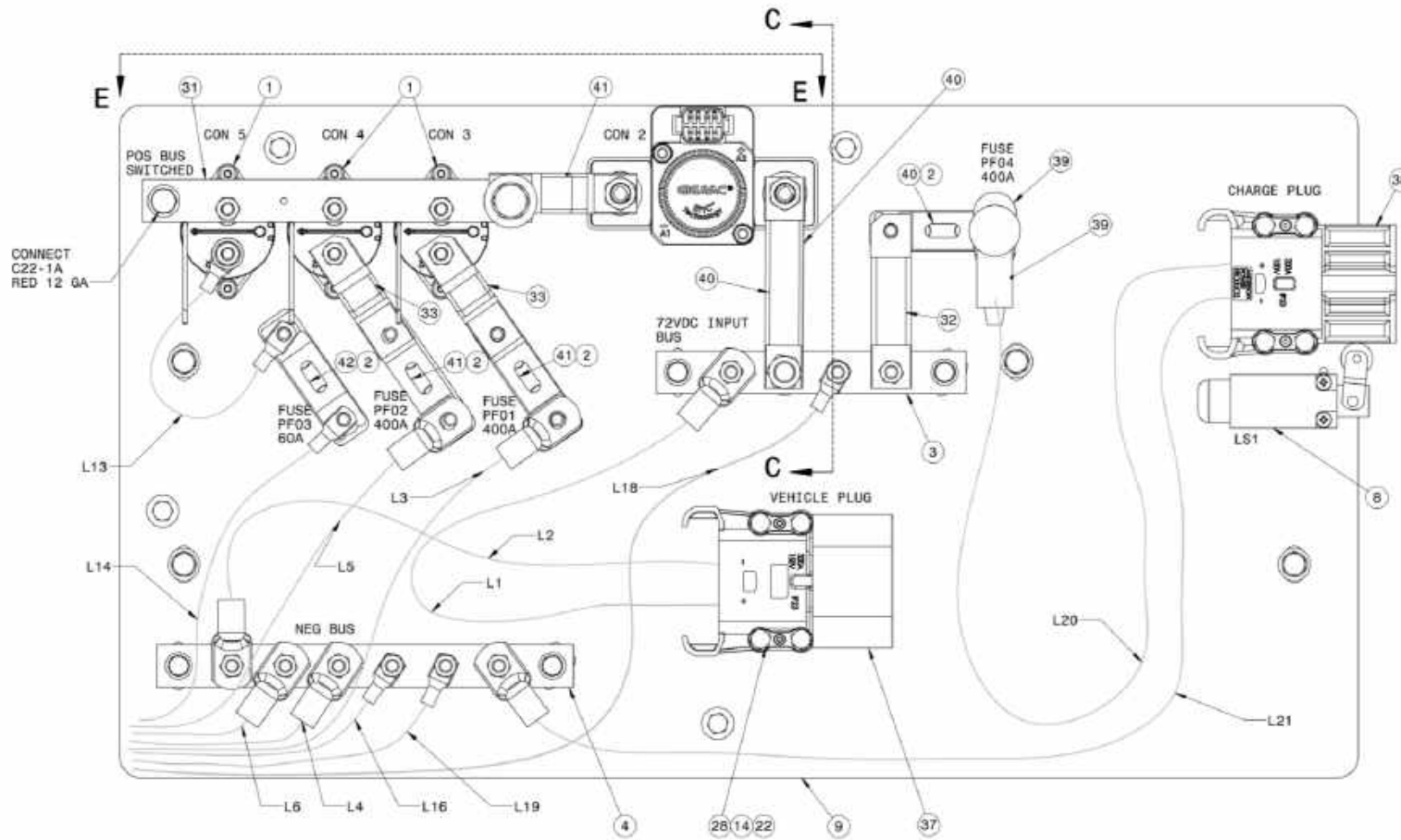
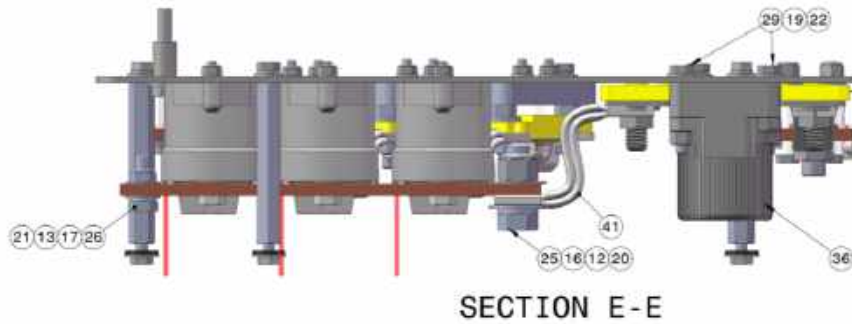

**Parts List**

When ordering replacement parts/kits, please specify model, serial number and color of your unit.

SECTION C-C

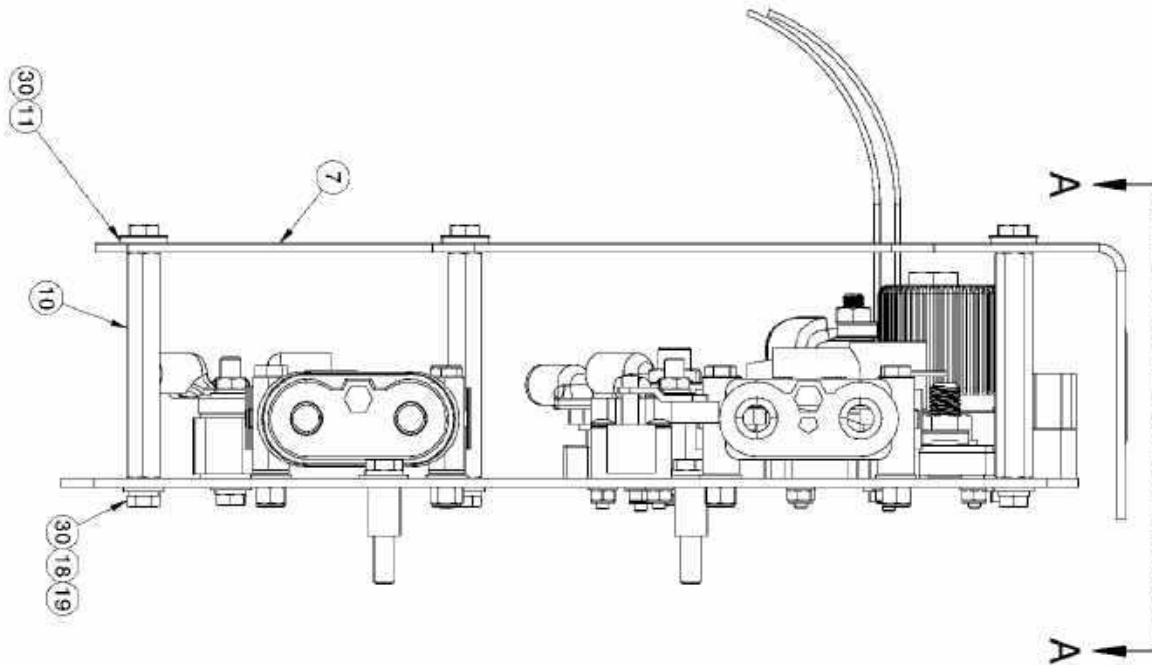
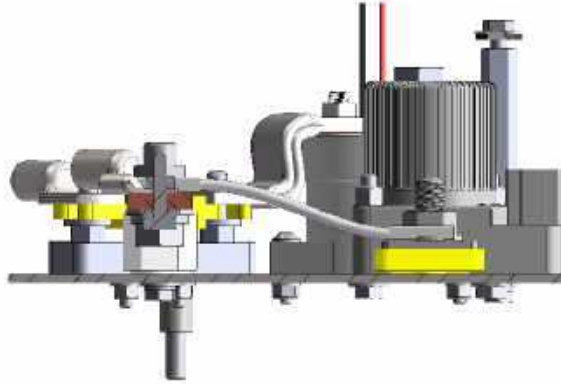

SECTION A-A

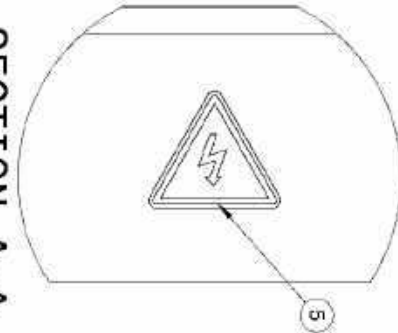

**Parts List**

When ordering replacement parts/kits, please specify model, serial number and color of your unit.

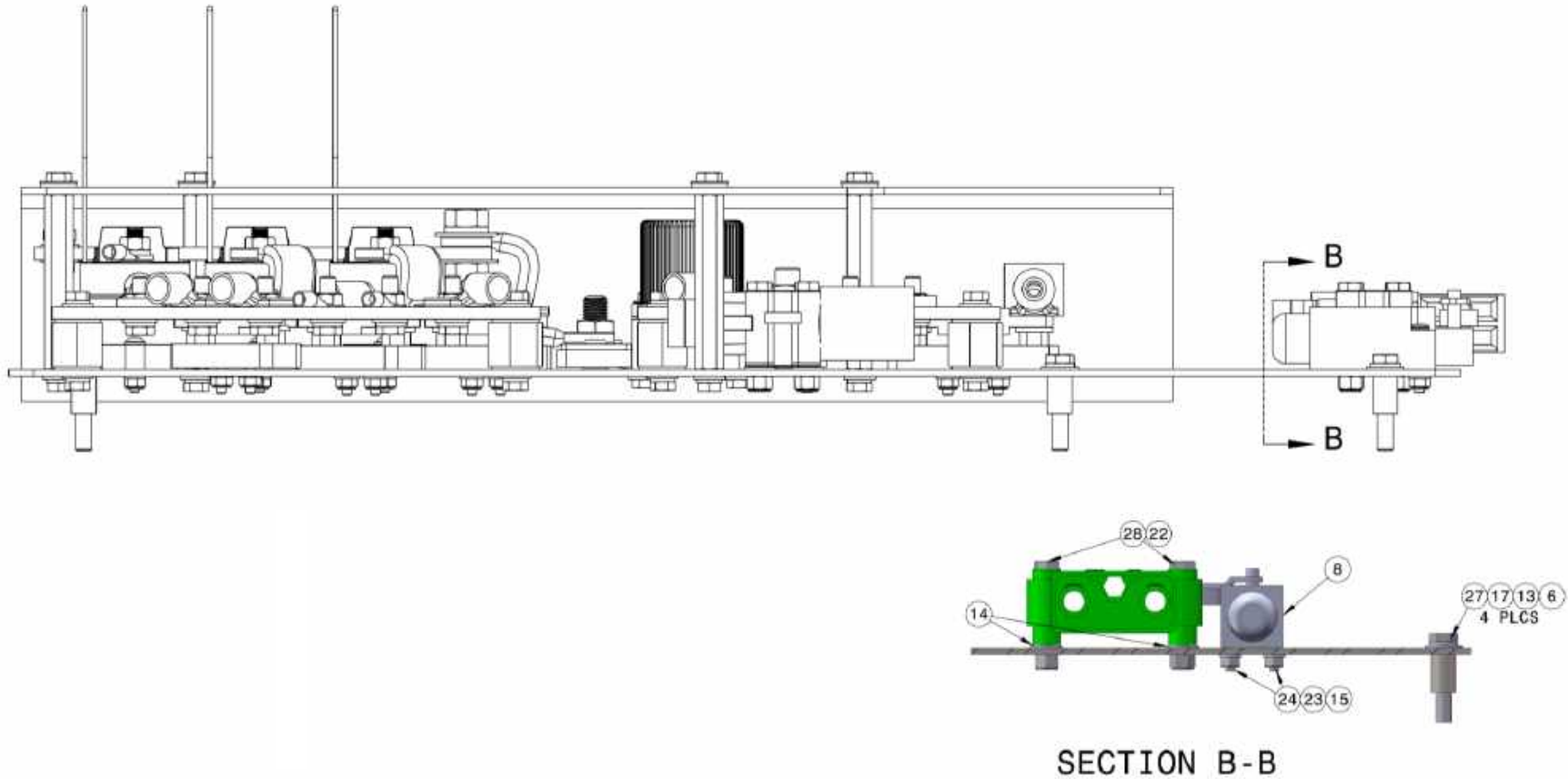

### Parts List

When ordering replacement parts/kits, please specify model, serial number and color of your unit.

Item	Part Number	Description	Qty
1	Z-9631	ASSEMBLY, CONTACTOR GV200QA-1 (48V COIL)	3
2	Z-9630	ASSEMBLY FUSE HOLDER	4
3	Z-9611	ASSEMBLY, BUSS BAR	1
4	Z-9610	ASSEMBLY, BUSS BAR	1
5	V-1050	LABEL, ISO ELECTRICAL SHOCK	1
6	TR377-03-000.75	TBG, SST .500D-.049W	4
7	S-3268	COVER, ELECTRICAL	1
8	JP-205 SWITCH	SWITCH	1
9	J-6522-00	CONTACTOR, PANEL (P)	1
10	H-3875	STANDOFF, FEMALE 1/4-20 X 3.5L	4
11	G-1658-13	WASHER, W/NEOPRENE 1/4 DIA	4
12	G-1503-1090N	FLATWASHER. 1/2 SST NARROW	2
13	G-1503-1060N	FLATWASHER. 5/16 SST NARROW	6
14	G-1503-1050N	FLATWASHER. 1/4 SST NARROW	8
15	G-1503-1030N	FLATWASHER. #10 SST NARROW	2
16	G-1502-1090R	LOCKWASHER, 1/2 SST REGULAR	1
17	G-1502-1060R	LOCKWASHER, 5/16 SST REGULAR	5
18	G-1251-1050R	LOCKWASHER, 1/4 REGULAR	4
19	G-1250-1050N	FLATWASHER. 1/4 NARROW	6
20	G-1202-1090	STOPNUT, 1/2-13 ELASTIC	1
21	G-1202-1060	STOPNUT, 5/16-18 ELASTIC	1
22	G-1202-1050	STOPNUT, 1/4-20 ELASTIC	10
23	G-1202-1035	STOPNUT, #10-32 ELASTIC	2
24	G-1157-103512	SCREW, #10-32 X 1-1/4" LG PAN HD CROSS RECESS	2
25	G-1112-109014	BOLT, 1/2-13 X .1-1/2" SST HEX HD	1
26	G-1112-106010	BOLT, 5/16-18 X 1.0" LG. SST HEX HD	1
27	G-1100-106016	BOLT, 5/16-18 X 1-3/4" LG. HEX HD GR 5	4
28	G-1100-105020	BOLT, 1/4-20 X 2.0" LG HEX HD GR 5	8
29	G-1100-105016	BOLT, 1/4-20 X 1-3/4" LG HEX HD GR 5	2
30	G-1100-105004	BOLT, 1/4-20 X 1/2" LG. HEX HD GR 5	8
31	EC-2999	COPPER BUSBAR	1
32	EC-2998	CABLE, FLEXIBLE BRAIDED	1
33	EC-2998	CABLE, FLEXIBLE BRAIDED	2
41	EC-2997	CABLE, FLEX BRAIDED	1
40	EC-2997	CABLE, FLEX BRAIDED	1
36	EC-2987	CONNECTOR 600 AMP 12-800 VDC	1
37	EC-2447-02A	EBC CONNECTOR, A32 MALE	1
38	EC-2446-02A	EBC CONNECTOR, A32 FEMALE	1
39	EC-2110	BATTERY, TERMINAL INSULATOR	1
40	EC-1624-19	FUSE, VERY FAST ACTING	1
41	EC-1619-18	FUSE, LOW VOLTAGE LIMITER	2
42	EC-1619-04	FUSE, LOW VOLTAGE LIMITER	1



## **APPENDIX I**

### **Wiring Diagram INS-2441**







DIRECT TO CONTROLLER CONNECTIONS

MASTER

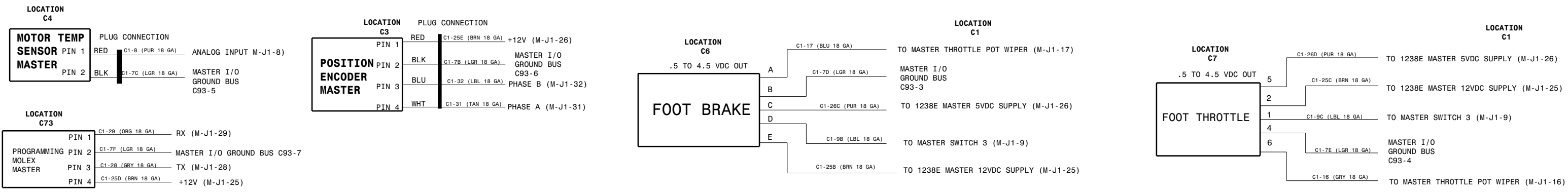

SLAVE

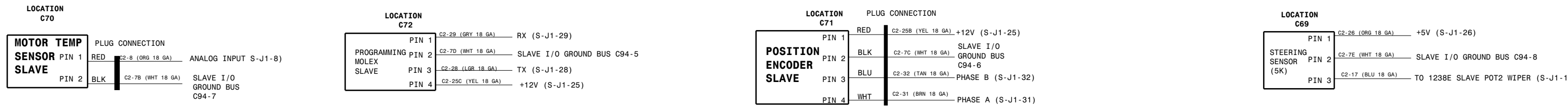

PUMP

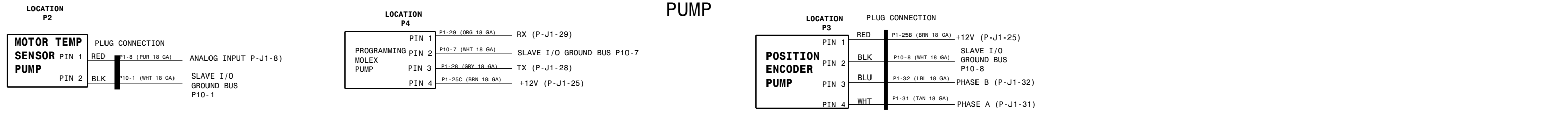

CONNECTION NOTES:  
 S-J1-21 (CAN TERM H) IS CONNECTED TO S-J1-34 (CAN TERM L) WITHIN THE EC-3055 WIRE HARNESS.  
 THIS CONNECTION UTILIZES THE 120 OHM RESISTOR IN THE SLAVE CONTROLLER.  
 THE REMAINDER OF THE CAN CONNECTIONS ARE MADE USING EC-3304 CAN HARNESS.  
 THE CAN HARNESS CONTAINS THE SECOND 120 OHM RESISTOR.

LET	REVISION	EC	OWN	CHK	DATE
A	ORIGINAL RELEASE				
B	SHEET 1 B1 CHANGED 016 CONNECTIONS. B2 AND PARK BRK RELEASE BUTTON. SHEET 2 B4 AND P33 AND INDICATOR LIGHT. B5 AND B71 FROM VALVE. B6 K4 NOT USED. B7 DELETED C74 RESISTOR. SHEET 3 B3 I/O AND CONNECTIONS ARE NOW I/O AND CONNECTIONS.	21568	GAM	KJY	07-30-2020

MAKE FROM: N/A  
 MATERIAL: N/A  
 FINISH: N/A  
 THERM ANGLE PRODUCTION: N/A  
 SCALE: N.T.S.  
 DO NOT SCALE DRAWING

DECIMAL TYPING: N/A  
 FRACTION TYPING: N/A  
 TOLERANCES UNLESS OTHERWISE SPECIFIED: N/A  
 DIMENSIONS UNLESS OTHERWISE SPECIFIED: N/A  
 DIMENSIONS UNLESS OTHERWISE SPECIFIED: N/A  
 DIMENSIONS UNLESS OTHERWISE SPECIFIED: N/A  
 DIMENSIONS UNLESS OTHERWISE SPECIFIED: N/A

TRONAIR  
 AIRCRAFT EQUIPMENT  
 SCHEMATIC, eJP10/  
 eJP-12 ELECTRICAL  
 INS-2441





## **APPENDIX II**

### **Hydraulic Schematic INS-2387**



THIS DRAWING IS THE PROPERTY OF TRONAIR, INC. IT IS FURNISHED TO YOU FOR CONFIDENTIAL INFORMATION PURPOSES ONLY AND IS NOT TO BE DISCLOSED TO ANYONE ELSE OR REPRODUCED OR USED FOR MANUFACTURING PURPOSES WITHOUT THE EXPRESS WRITTEN PERMISSION OF TRONAIR, INC.

LET	REVISION	ECN	DWN	CHK	DATE
A	ORIGINAL RELEASE	20311	-	-	06-20-17
B	ADDED PS3	21568	GAM	KJY	07-29-2020

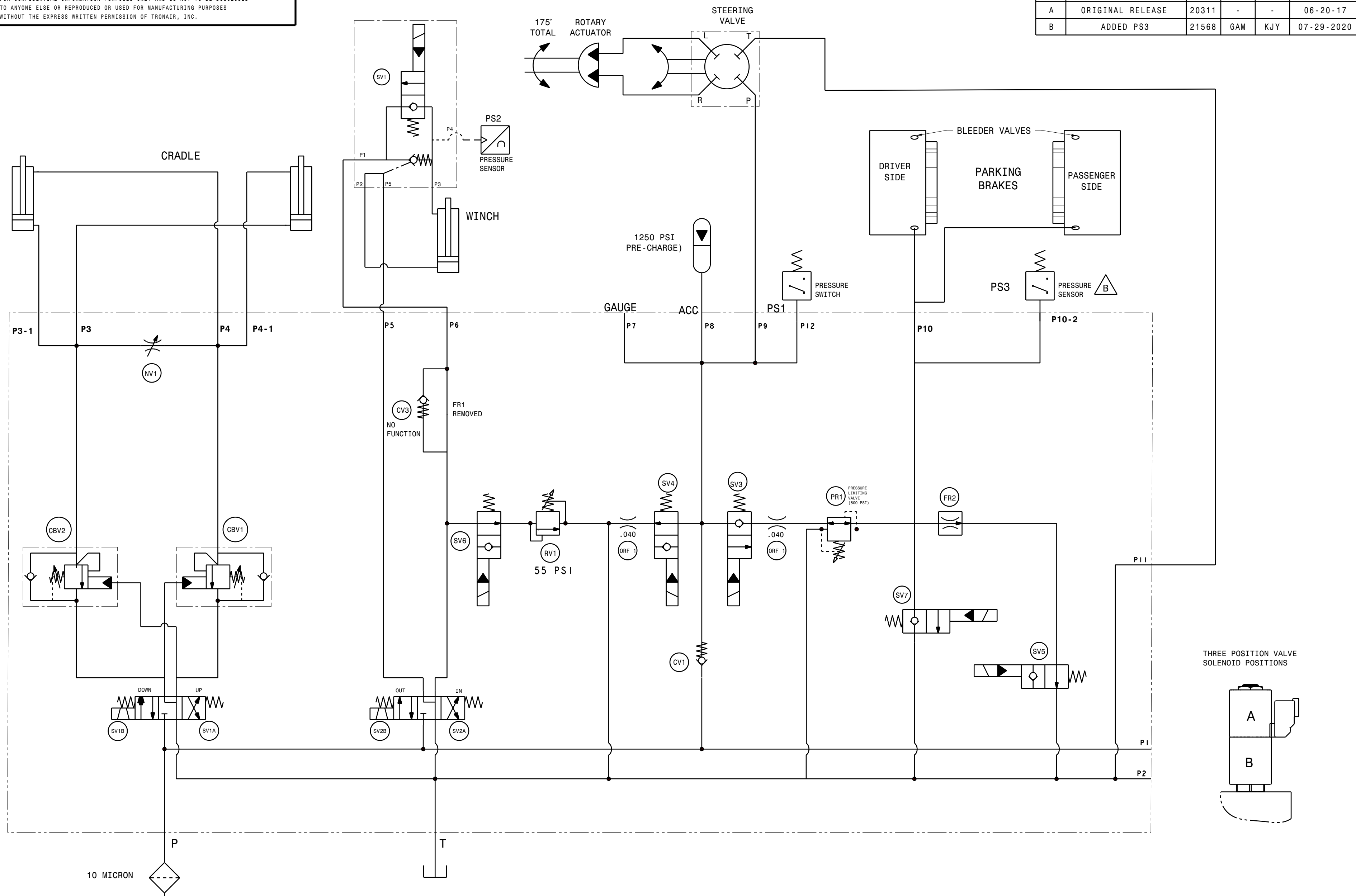

MAKE FROM: N/A	TYPE: N/A
MATERIAL: N/A	FINISH: MILL
THIRD ANGLE PROJECTION	SIZE <b>C</b>
SCALE: N.T.S.	DO NOT SCALE DRAWING

BREAK ALL SHARP EDGES AND CORNERS  
TOLERANCES UNLESS OTHERWISE SPECIFIED

DECIMAL	.X	± .100
	.XX	± .030
	.XXX	± .010
FRACTION	X/XX	± 1/16
ANGLES: ± 1/2 DEGREE		
< > INDICATES CRITICAL DIMENSIONS		
( ) INDICATES REFERENCE DIMENSIONS		

**TRONAIR** AIRCRAFT GROUND SUPPORT EQUIPMENT

DWN BY	GAM	CKD BY	GAM	DATE	06-20-17
<b>SCHEMATIC, HYDRAULIC</b>					
JP	<b>INS-2387</b>			REV	B





## **APPENDIX III**



### **Battery Care and Maintenance**





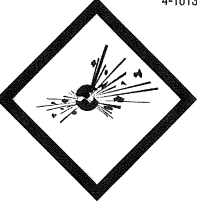

# THIS SUPPLEMENT CONTAINS IMPORTANT UPDATED SAFETY AND HANDLING INFORMATION

## MOTIVE POWER FLOODED

4-1013

**DANGER**  
Contains: Lead, Sulfuric Acid (Electrolyte), Lead Compounds.

 <p>Harmful if swallowed, inhaled, or in contact with skin. Acid causes severe skin burns and eye damage. May damage fertility or the unborn child if ingested or inhaled.</p>	 <p>May cause harm to breast-fed children. May cause cancer if ingested or inhaled. Causes skin irritation, serious eye damage. Contact with internal components may cause irritation or severe burns.</p>	 <p>Causes damage to central nervous system, blood and kidneys through prolonged or repeated exposure if ingested or inhaled. Irritating to eyes, respiratory system, and skin. May form explosive air/gas mixture during charging. Extremely flammable gas (hydrogen). Explosive, fire, blast or projection hazard. Obtain special instructions before use.</p>	 <p>Do not handle until all safety precautions have been read and understood. Wash thoroughly after handling. Do not eat drink or smoke when using this product. Avoid contact during pregnancy/while nursing. Wear protective gloves/protective clothing, eye protection/face protection.</p>
--	---	---	---

**PROPOSITION 65 WARNING:** Battery posts, terminals and related accessories contain lead and lead compounds, chemicals known to the State of California to cause cancer and reproductive harm. Batteries also contain other chemicals known to the State of California to cause cancer. **WASH HANDS AFTER HANDLING.**

**WARNING:** Risk of fire, explosion or burns. Do not disassemble or incinerate. Not recommended for inverted use. Follow product charging instructions.

**High Voltage:** Risk of shock. Do not touch uninsulated terminals or connectors.

**Keep Vent Caps Tightly in Place**

**Manufactured by: East Penn Manufacturing Co.,  
102 Deka Road, Lyon Station, PA 19536 USA 610-682-6361**

**Lead Acid  
Battery  
Electrolyte  
(Sulfuric Acid)**



[www.dekabatteries.com](http://www.dekabatteries.com)



East Penn Manufacturing Co. Lyon Station, PA 19536-0147 Phone: 610-682-6361 Fax: 610-682-4212

E.P.M. Form No. 2162 5/15 © 2015 by EPM Printed in U.S.A.

All data subject to change without notice. No part of this document may be copied or reproduced, electronically or mechanically, without written permission from the company.



## EAST PENN manufacturing co., inc.

LYON STATION, PA 19536 • 610-682-6361

Congratulations on your choice of a new Deka industrial battery. The complete line of Deka industrial batteries incorporates every feature required by today's user of electric industrial trucks. Designed with East Penn engineering technology and built by master battery craftsmen according to strict quality assurance guidelines, Deka industrial batteries are the finest available to meet today's material handling requirements. Deka precision construction provides new equipment performance throughout a long life. This battery has been inspected prior to shipment to insure that it meets your specifications as ordered. By following the operating and maintenance instructions, you will be insuring optimum life and performance of your new Deka industrial battery.

### OPERATING INSTRUCTIONS

⚠ DANGER			
 <b>HIGH VOLTAGE...</b> RISK OF SHOCK. DO NOT TOUCH UNINSULATED TERMINALS OR CONNECTORS.	 <b>EXPLOSIVE GASES</b> CAN CAUSE BLINDNESS OR INJURY.	 <b>NO</b> • SPARKS • FLAMES • SMOKING	 <b>SULFURIC ACID</b> CAN CAUSE BLINDNESS OR SEVERE BURNS.
 <b>SHIELD EYES.</b>		 <b>FLUSH EYES IMMEDIATELY WITH WATER.</b>	
 <b>GET MEDICAL HELP FAST.</b>		 <b>VENTILATE WELL WHEN IN AN ENCLOSED SPACE AND WHEN CHARGING.</b>	
<b>KEEP VENT CAPS TIGHTLY IN PLACE.</b>		<b>REPAIR SHOULD BE PERFORMED ONLY BY A QUALIFIED SERVICE TECHNICIAN.</b>	
<b>SEE INSTALLATION, MAINTENANCE AND OPERATION INSTRUCTIONS FOR IMPORTANT SAFETY PRECAUTIONS.</b>		<b>REPAIR SHOULD BE PERFORMED ONLY BY A QUALIFIED SERVICE TECHNICIAN.</b>	

#### CALIFORNIA Proposition 65 Warning

Battery posts, terminals and related accessories contain lead and lead compounds, and other chemicals known to the state of California to cause cancer and birth defects or other reproductive harm. **Wash hands after handling.**

BATTERIES AND RELATED PARTS CONTAIN LEAD	
<b>WASH HANDS AFTER HANDLING!</b>	
<small>CALIFORNIA PROPOSITION 65 WARNING: Batteries, battery posts, terminals and related accessories contain lead and lead compounds, and other chemicals known to the State of California to cause cancer and birth defects or other reproductive harm.</small>	
<small>California Proposition 65 Workplace Warning Sign 7/04 Must be posted in workplace near batteries.</small>	

1. Upon receipt of the battery, if there are signs of rough handling or of electrolyte leakage, file a claim with the carrier and advise your East Penn representative.

The electrolyte level should normally be above the perforated separator protector, which can be seen in the cell when the vent caps are removed. However vibrations during shipping often shake enough gas out of the cell that the electrolyte level may drop below the separator protector, especially on taller cells. If the electrolyte level is still above the top of the plates and can be seen with a flashlight through the holes in the separator protector, the battery may be given its initial charge without adjusting the electrolyte level.

If the electrolyte level is not visible or is below the top of the plates, check again for leaking cells and call your East Penn representative before charging the battery.

2. Check the nameplate of your charger against the nameplate of the battery to make sure they both show the same voltage and that the six-hour ampere hour capacity of the battery falls within the eight-hour recharge range of the charger.
3. The "Battery Type Identification" shown on the battery (E, EO, EE, EX) should match the "Battery Type Identification" specified on the truck nameplate.
4. Make sure that the battery "SERVICE WEIGHT," which is stamped below the lifting hole in the steel tray, falls within the battery weight range shown on the truck nameplate. East Penn Manufacturing Co., Inc. cannot be responsible for determining that the battery weight is sufficient to counterbalance your particular truck.
5. Prior to placing the battery in service, it should be given an equalizing charge. Near the end of the charge, check to make sure

that the electrolyte levels of all cells are visible and above the separator protector. The full charge specific gravity is 1.280 to 1.295 when temperature corrected to 77°F (25°C).

6. Upon installation in the truck, battery restraints should be adjusted to restrict movement of the battery to no more than 1/2" in a horizontal direction. An insulated spreader bar should be used any time the battery is lifted or hoisted.
7. Batteries normally should not be discharged more than 80% of their rated capacity for longest service life. Section III of DEKA INDUSTRIAL BATTERY SERVICE MANUAL 0656 gives detailed information for your specific battery type.
8. The battery should be placed on charge upon completion of the work shift and returned to full charge. If at the end of the work shift the specific gravity has not fallen below 1.230, it is advisable to use the battery for another shift. Normally, batteries should not be used for more than two successive shifts before recharging. All vent caps should be kept in place and the steel tray cover or the truck compartment cover kept open while charging.
9. After the daily charge and prior to the start of the workshift, a specific gravity reading should be taken with a hydrometer on at least one cell in order to insure full recharge. The specific gravity should be between 1.280 and 1.295 when temperature corrected to 77°F (25°C).
10. A copy of the DEKA INDUSTRIAL BATTERY SERVICE MANUAL, which gives more detailed information on the Operation and Maintenance of motive power batteries, can be obtained from your Deka representative by asking for form number 0656.

# MAINTENANCE

1. Once each week the electrolyte level should be checked in every cell. It may be necessary to add water to the battery on a weekly to a monthly basis, depending on the type of battery and the type of service for which it is used.
2. Only distilled, deionized or approved water should be added to the battery. Water should be added only near the end of the charge to raise the electrolyte level to the bottom of the vent well. Water should be stored in a clean non-metallic container as impurities, even in small amounts, may be harmful to battery life.
3. Depending on the type of service, it will be necessary to give the battery an equalizing charge every one to four weeks. Set the charger to the equalize position.
4. Specific gravity readings should be recorded for all cells once each month immediately after an equalizing charge. If the readings average below 1.265, the charger output should be checked. If two successive monthly readings indicate more than 20 points deviation in any cell from the average specific gravity, you should contact your Deka representative.
5. The top of the battery should be kept clean and dry at all times. When required, the top of the battery should be neutralized, after removing the shrouds, with a non-corrosive water based neutralizing solution. Make sure vent caps are securely in place to prevent any solution from entering cells. After the battery has been neutralized, rinse thoroughly with clear water, dry and then reinstall the cleaned shrouds.
6. The cables and connectors should be inspected monthly for exposed copper wires, fraying or cracked insulation, loose connections, or pitted contacts, and repaired as required.
7. Be especially careful to keep metallic objects off the top of the battery, as any metal touching two or more connectors may cause a short circuit resulting in an arc or spark which could ignite battery gasses explosively.
8. The output rate of the charger should be checked periodically. The starting rate should correspond to the starting rate shown on the charger nameplate. The following chart shows the ampere hour capacity at the six-hour rate, as well as the recommended finish rate for every cell size in the Deka D-Series manufactured by East Penn Manufacturing Co., Inc.

TYPE	PLATES PER CELL	5	7	9	11	13	15	17	19	21	23	25	27	29	31	33
D35	6 HR. A.H. RATING	70	105	140	175	210	245	280	315	350	385	420	455	490	525	560
	FINISH RATE—AMPS	4	5	7	9	10	12	14	16	18	19	21	23	24	26	28
D45	6 HR. A.H. RATING	90	135	180	225	270	315	360	405	450	495	540	585	630	675	720
	FINISH RATE—AMPS	4	7	9	11	14	16	18	20	22	25	27	29	32	34	36
D55	6 HR. A.H. RATING	110	165	220	275	330	385	440	495	550	605	660	715	770	825	880
	FINISH RATE—AMPS	6	8	11	14	16	19	22	25	28	30	33	36	38	41	44
D65	6 HR. A.H. RATING	130	195	260	325	390	455	520	585	650	715	780	845	910	975	1040
	FINISH RATE—AMPS	6	10	13	16	20	23	26	29	32	36	39	42	46	49	52
D75	6 HR. A.H. RATING	150	225	300	375	450	525	600	675	750	825	900	975	1050	1125	1200
	FINISH RATE—AMPS	8	11	15	19	22	26	30	34	38	41	45	49	52	56	60
D85	6 HR. A.H. RATING	170	255	340	425	510	595	680	765	850	935	1020	1105	1190	1275	1360
	FINISH RATE—AMPS	8	13	17	21	26	30	34	38	42	47	51	55	60	64	68
D100	6 HR. A.H. RATING	200	300	400	500	600	700	800	900	1000	1100	1200	1300	1400	1500	1600
	FINISH RATE—AMPS	10	15	20	25	30	35	40	45	50	55	60	65	70	75	80
D110	6 HR. A.H. RATING	220	330	440	550	660	770	880	990	1100	1210	1320	1430	1540	1650	1760
	FINISH RATE—AMPS	11	16	22	28	33	38	44	50	55	60	66	72	77	82	88
D125	6 HR. A.H. RATING	250	375	500	625	750	875	1000	1125	1250	1375	1500	1625	1750	1875	2000
	FINISH RATE—AMPS	12	19	25	31	38	44	50	56	62	69	75	81	88	94	100
D150	6 HR. A.H. RATING			600	750	900	1050	1200	1350	1500						
	FINISH RATE—AMPS			30	38	45	52	60	68	75						
D160	6 HR. A.H. RATING			640	800	960	1120	1280	1440	1600						
	FINISH RATE—AMPS			32	40	48	56	64	72	80						



# INDUSTRIAL BATTERY *Service Manual*

*Operation and maintenance  
for motive power  
batteries.*



## Table of Contents

	Page		Page
INTRODUCTION .....	2	SECTION III - INSTALLATION AND USE (Cont.)	
SECTION I - THEORY OF		Operation of the Battery .....	13
OPERATION/BATTERY CONSTRUCTION .....	4	Specific Gravity and On-Charge .....	
Discharging/Recharging Characteristics .....	4	Cell Voltage Temperature Correction .....	13
Battery Ratings .....	4	BATTERY CHARGING .....	13
Battery Voltage .....	4	Basic Charging Facts .....	13
Ampere Hour (AH) .....	5	Specific Gravity Temperature Correction .....	14
Kilowatt Hours (KWH) .....	5	Charging Methods .....	14
Positive Plate Capacity .....	5	The Charging Process .....	14
Specific Gravity .....	5	Improper Charging .....	16
Specific Gravity During Recharge .....	5	Charging Safety .....	16
Grid Casting .....	6	SECTION IV - BATTERY MAINTENANCE	
Apply Active Material .....	6	AND TROUBLE SHOOTING .....	16
Curing and Drying .....	6	Reading Hydrometers and Thermometers .....	17
Plate Formation .....	6	Using a Voltmeter .....	17
Wrapping Positive Plates .....	6	Battery Inspection .....	17
Assembling An Element .....	7	Adding Water/Adjust Electrolyte Levels .....	18
Finishing the Cell Assembly .....	7	Battery Cleaning Wash Unit .....	18
Assembling into Trays .....	8	Performing a Test Discharge .....	19
Battery Finishing and Shipping .....	8	Correcting a Sulfated Battery .....	19
SECTION II - BATTERY SAFETY .....	9	Procedure for Adjusting the	
Hazardous Elements .....	9	Specific Gravity of the Electrolyte of a Battery .....	20
Wearing Protective Clothing .....	9	Storage Battery Troubleshooting Chart .....	21
Lifting Batteries .....	9	Basic Rules for Battery Care and Maintenance .....	23
Using the Battery as a Counterbalance .....	9	SECTION V - VALVE REGULATED	
CHARGING BATTERIES		LEAD-ACID BATTERIES .....	24
Charging Areas — Proper Equipment .....	10	Operation of a Gel Cell .....	24
Charging Areas — Proper Ventilation .....	10	Charging a Gel Cell .....	24
Connecting/Disconnecting Charger .....	10	Operating Instructions .....	25
Sparks/Open Flames .....	10	Maintenance Instructions .....	26
HANDLING ACID		SECTION VI - BATTERY REPAIR	
Pouring Acid .....	10	Repair or Replace .....	27
Mixing Electrolyte .....	10	Gas Purging .....	27
First Aid for Acid Splash .....	10	Removing Connectors .....	27
Eye Wash and Emergency Shower Facilities .....	11	Removing a Cell .....	27
Neutralizing Acid and Electrolyte .....	11	Removing an Element .....	28
Repairing Batteries .....	12	Reassembling the Battery .....	29
SECTION III - INSTALLATION AND USE .....	12	Using Sealing Compound .....	30
Receiving a Battery .....	12	Attaching Intercell Connectors .....	30
Temporary Storage .....	12	Replacing Acid and Charging .....	30
Placing a Wet Charged Battery in Service .....	12	SECTION VII - SAFETY DATA SHEETS .....	31-48
Placing a Dry Charged Battery in Service .....	13	GLOSSARY OF BATTERY TERMINOLOGY .....	49-53
Cycling Characteristics .....	13		

## INTRODUCTION

Storage batteries do not store electrical energy, but convert electrical energy into chemical energy which is slowly accumulated as the charge progresses. A battery in use is said to be on discharge. During discharge, the chemical energy stored in the battery is converted into usable electrical energy.

A lead-acid motive power battery supplies direct current (DC) power to electric lift trucks, tractors and pallet trucks. This type of battery consists of a metal tray containing cells, connected in series. These batteries come in a wide variety of shapes, sizes, voltages and ampere-hour capacities.

Each cell in a motive power battery contains positive and negative plates. All of the positive plates are joined in parallel to the positive post and strap, to form a positive group. The negative plates also are joined in parallel to the negative post and strap to form a negative group. These groups are separated and insulated from one another and they are immersed in a solution of sulfuric acid and water, called electrolyte. These groups of plates, separators, posts and straps are called an element and it is contained in an acid-proof plastic jar.

The cutaway illustration (Fig. A-1) shows the construction of an East Penn battery cell. Each positive plate consists of a lead-alloy grid structure which is filled with a paste of active material, made from lead oxide. The active material is forced into the positive grid structure during manufacturing and is held firmly to the grid by a system of vertical and horizontal glass fiber mats, which reinforce and insulate the positive plate. A retainer and bottom shield encase each positive plate and mat assembly to help prevent short circuits.

The negative plate also consists of a lead alloy grid structure that is filled with active material. But because negative plates undergo much less active material shedding, no reinforcing glass fiber mats are needed. Separators provide insulation between the positive and negative plates. The positive and negative plates are connected to their respective posts by positive and negative straps.

A more detailed description of battery construction appears in Section I.

Manufactured using the world's most modern computer integrated manufacturing techniques...

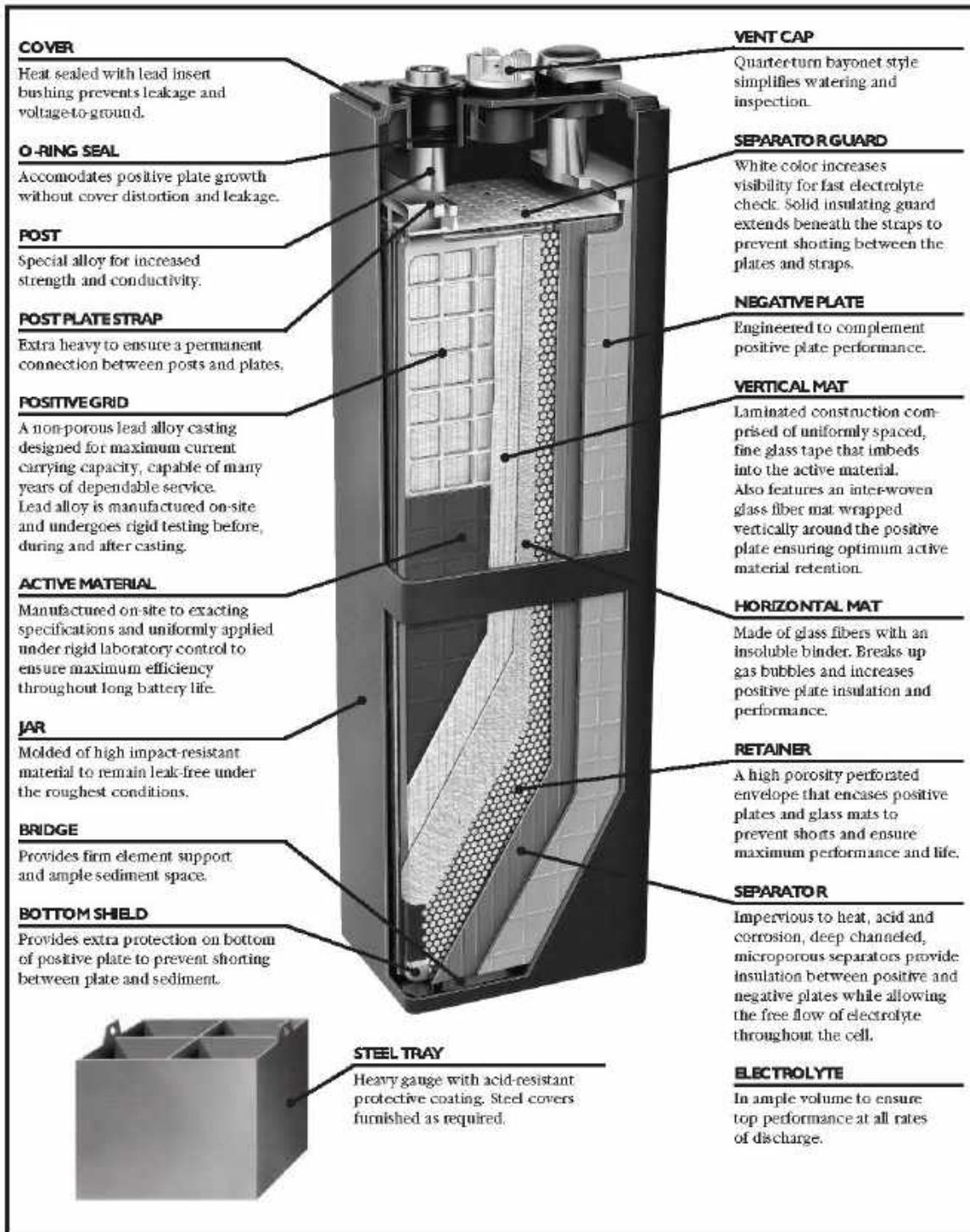

Fig. A-1

## SECTION I - THEORY OF OPERATION/BATTERY CONSTRUCTION OF LEAD ACID STORAGE BATTERIES

### Theory of Operation

#### Discharging/Recharging Characteristics

In a fully charged condition the active material in the positive plate is lead peroxide ( $PbO_2$ ) and the active material in the negative plates is sponge lead ( $Pb$ ). The electrolyte has maximum sulfuric acid content and its temperature corrected specific gravity ranges should comply with the manufacturer's recommended full charge specific gravity specifications (See Table 1-1). (See Table 3-1 - shown on page 14 - Specific Gravity Temperature Corrections).

Battery Type	Recommended Specific Gravity Range @ 77°F/25°C
Standard "D" Series	1.280 - 1.295
Maintenance Saver "M" Series	1.245 - 1.255
Max Power "P" Series	1.320 - 1.330
Diesel Starting "DL/DLU" Series	1.245 - 1.255
Hydra Saver "H" Series	1.295 - 1.305

Table 1-1

When fully charged, each cell has a voltage of approximately two (2) volts on open circuit. However, a cell may have a voltage from 2.12 to 2.70 volts while being charged. A cell develops a voltage potential when two dissimilar metals are immersed in a suitable electrolyte. The two metals used in lead-acid cells are lead peroxide ( $PbO_2$ ) and sponge lead ( $Pb$ ), and the electrolyte is dilute sulfuric acid ( $H_2SO_4$ ). This combination of dissimilar metals and electrolyte results in a voltage potential of nominally two (2) volts per cell and their potential ability to deliver this voltage under varying load and for varying periods of time.

When a battery is discharged, the internal components of each cell undergo chemical changes (Figure 1-1). During the discharge cycle, the composition of the positive plates changes from lead peroxide ( $PbO_2$ ) to lead sulfate ( $PbSO_4$ ) and the negative plates from sponge lead ( $Pb$ ) to lead sulfate ( $PbSO_4$ ). The sulfate on both the positive and negative plates comes from the sulfuric acid in the electrolyte solution combining chemically with the active material of the plates. This chemical reaction reduces the sulfuric acid content in the electrolyte. The specific gravity of the electrolyte is reduced and approaches that of water (1.100). Cell voltage decreases during the discharge because the two (2) dissimilar metals ( $PbO_2$ ) and ( $Pb$ ) are becoming more similar ( $PbSO_4$ ).

During charging, the discharging reaction is reversed and the chemical energy is restored. The lead sulfate on the positive plates converts back to lead peroxide ( $PbO_2$ ) and the lead sulfate on the negative plates converts back to sponge lead ( $Pb$ ). The released sulfate returns to the electrolyte solution, increasing the sulfuric acid content, which in turn increases the specific gravity. When these electrochemical reactions are complete, the cell is again fully charged.

During charging, hydrogen gas is formed on the negative plates and oxygen is formed on the positive plates. This explosive gas mixture is vented from the battery through the vent/filler caps. THE WARNINGS (SHOWN ON PAGE 5) APPLY TO ALL CELLS OR BATTERIES.

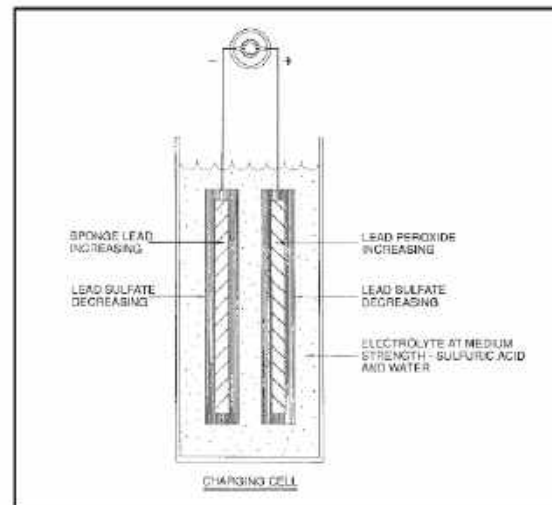
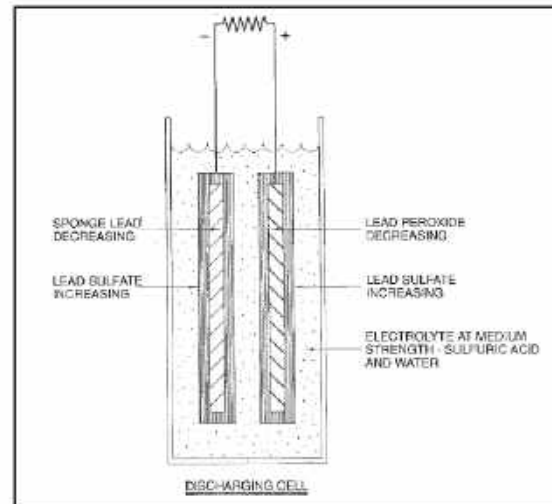

Fig. 1-1

#### Battery Ratings

A single lead-acid cell does not have sufficient power to handle most requirements. However, connecting a number of cells together in series results in a battery capable of supplying higher power demands.

#### Battery Voltage

The number of cells is determined by the required nominal operating voltage of the equipment. Since each cell has a nominal voltage of two (2) volts, a 36 volt industrial truck will require an 18-cell battery (18 cells x 2 volts/cell = 36 volts).



## SECTION I - THEORY OF OPERATION/BATTERY CONSTRUCTION OF LEAD ACID STORAGE BATTERIES (cont.)

### Battery Construction

#### Grid Casting - Positive and Negative Grids

A plate consists of a cast lead-alloy grid structure into which lead oxide pastes are applied. Since lead by itself would be too soft and flexible to make a grid, a certain amount of antimony is added to the grid to prevent it from sagging or warping. The grids are then cast by pouring the molten alloy into grid molds.

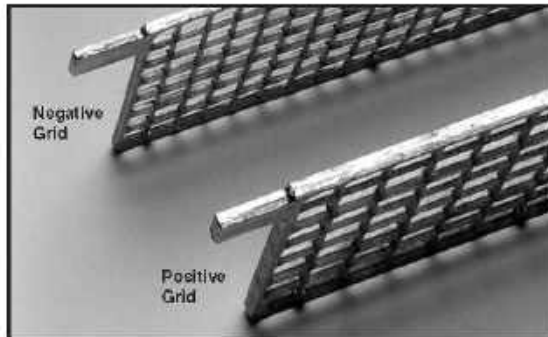

Fig. 1-2

Due to the increased amount of chemical activity that takes place on the positive grids during charging and discharging, positive grids are more heavily constructed than negative grids (Fig. 1-2).

#### Apply Active Material

After the grids have been cast, the lead oxide pastes are applied. The lead oxide applied to the negative grid contains an expander to produce sponge lead. The positive plate contains a putty-like mixture of lead, lead oxide, lead sulfate and water. Because proper pasting is critical to battery performance, East Penn uses highly sophisticated, computer-controlled pasting machines to consistently apply paste to exact thicknesses and weight.

#### Curing and Drying

After the plates are pasted, they must be cured and dried in a rigidly controlled environment. This securely binds the active material to the grid and produces a smooth, uniform plate. The active material, now highly porous, allows the electrolyte to penetrate freely so it can produce maximum conductivity between the paste and the grid for high cell efficiency. Because the curing and drying process is so important to cell efficiency and battery life, East Penn has invested in humidity and temperature-controlled curing ovens (Fig. 1-3), which produce the highest quality plates in the industry.

#### Plate Formation

The cured plates must now undergo a formation charge, which transforms the previously inert material on the positive plates into lead peroxide and the material on the negative plates into sponge lead. The plates are lowered into a forming tank filled with dilute sulfuric acid, then temporarily connected to a lead bar, and given a computer-controlled forming charge. Individual plate formation allows the entire row of plates to be formed at uniform temperatures, which will enhance battery performance



Fig. 1-3

and life. The formed plates become darker and are individually inspected (Fig. 1-4 and Fig. 1-5) to be sure that each one is perfect. This is important because many other companies form their plates in the battery, or in groups of cells, resulting in temperature variation between plates, and they can't individually inspect each one.

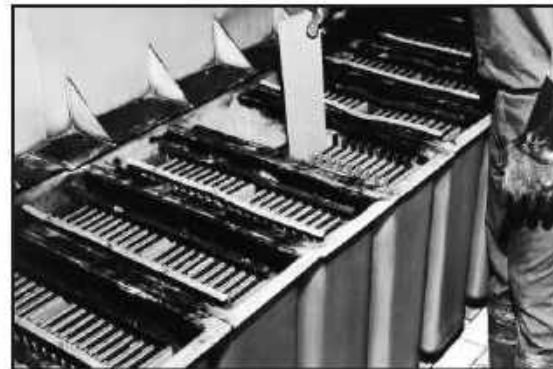

Fig. 1-4

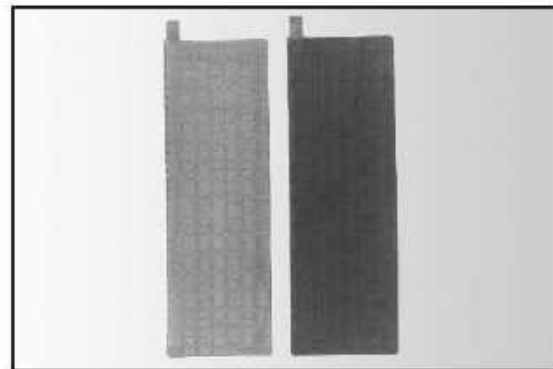
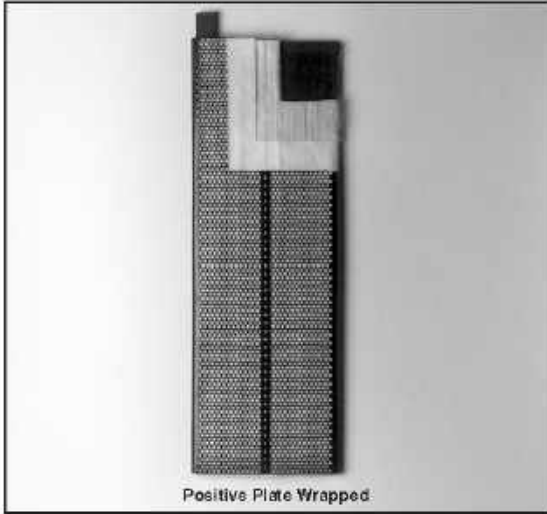

Fig. 1-5

#### Wrapping Positive Plates

The active material of positive plates (lead peroxide) is subject to shedding as a cell goes through its normal discharge/recharge cycle. The small particles that are shed settle to the bottom of the cell. To keep the active material firmly on the positive plates,

**SECTION I - THEORY OF OPERATION/BATTERY CONSTRUCTION OF LEAD ACID STORAGE BATTERIES (cont.)**



*Fig. I-6*

they are "wrapped" with various retaining devices including glass fiber mats, fiberglass tape and a retainer/bottom shield (Fig. I-6).

The positive plates are first wrapped with a vertical mat, which consists of fiberglass tape and interwoven glass fibers. The glass fibers imbed into the active material, strengthening in a way similar to reinforcing rods in concrete. A horizontal glass fiber mat is then wrapped around the plate to break up any gas bubbles and increase the plate's insulation. The wrapped plate is then encased in a perforated plastic retainer envelope that firmly holds the glass wraps in contact with the plate while allowing the free flow of electrolyte to the plate. A bottom plate boot is added to prevent the sediment in the sediment chamber from contacting the bottom of the positive and negative plates and shorting out the cell.

**Assembling An Element**

A group of positive and a group of negative plates are stacked with separators, inserted between each positive and negative

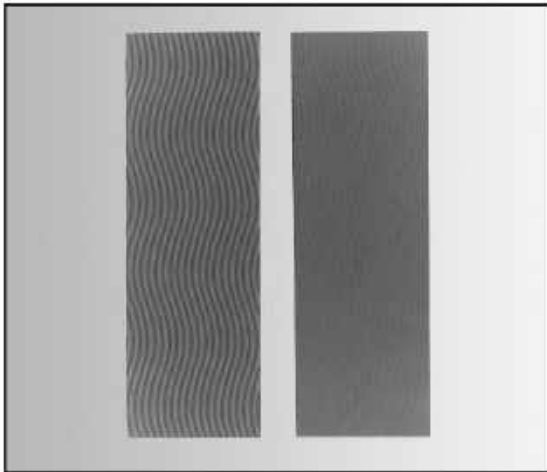
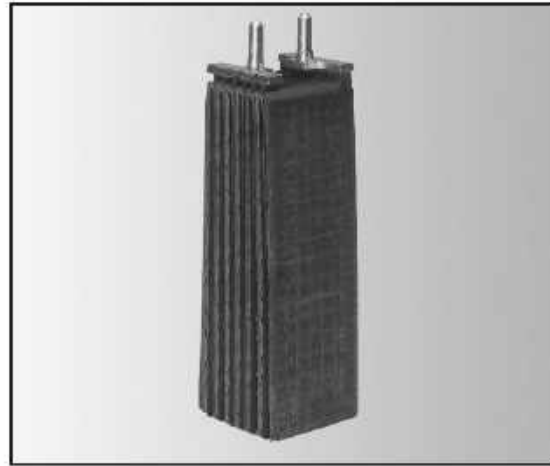

*Fig. I-7*

plate, to the desired cell size. Both outside plates are negative, therefore the number of plates per cell is always an odd number, with each cell having one more negative than positive plate.

The separators used to insulate the positive plate from the negative plate are grooved on one side and flat on the other (Fig. I-7). The grooved side faces the positive plate. The flat side faces the negative plate because the sponge lead of the negative plate would expand if it faced into the grooved side. In some cases, positive plates can be inserted into separator sleeves, which are two separators joined at the sides.

When assembling the stack of plates and separators into an element, a post plate strap is welded onto the positive plate lugs and another one is welded onto the negative plate lugs. At the same time, positive and negative posts are welded onto the proper plate straps. A perforated plastic moss shield is placed on top of the assembled plates (Fig. I-8). The moss shield also protects the tops of the plates and separators and permits the gas bubbles to get up to the surface of the electrolyte.



*Fig. I-8*

**Finishing the Cell Assembly**

A finished cell consists of an element inserted into a high-impact plastic jar with a cover (Fig. I-9). Before the element goes into the jar, a sediment bridge is installed to give the element firm support and provide a place for sediment to settle.

After the completed element is inserted into the jar, a high impact plastic cover is placed on top and heat sealed onto the jar. The cover's positive and negative terminals have a lead post bushing attached and are welded firmly to the element's posts.

Each finished cell is air tested to ensure an air tight cover-to-jar and post-to-bushing seal. The air test can also detect any leaks in the high impact plastic jar.

## SECTION I - THEORY OF OPERATION/BATTERY CONSTRUCTION OF LEAD ACID STORAGE BATTERIES (cont.)

### **Assembling into Trays**

To create a battery, a specific amount of completed cells (element, jar and cover) are inserted into a steel tray. Spacer material may be added between the cells and tray to assure a tight assembly.

East Penn will assemble batteries with or without a hot asphalt based sealing compound that is poured in the channels between cells, per customer request. East Penn recommends that sealing compound be used because it prevents dirt and flushed electrolyte from draining between the cells and tray. This internal build up of corrosive material over time could cause cell or tray damage and result in voltage shorts to ground that adversely effect lift truck electrical controls. Once all the jars have been sealed into the tray, intercell connectors are attached (Fig. I-10). Electrolyte is then added to the cells and the battery is moved to the boosting room for a final charge.

### **Battery Finishing and Shipping**

After the boost charge, the battery is sent to the finishing line, where cables and connectors are attached according to the buyer's layout specifications (Fig. I-11). The battery is then weighed, thoroughly cleaned, and inspected. Actual battery service weight and the tray drawing number are stamped on the steel tray, and all battery identification labels, warning labels, plaques, and service stickers are affixed to the tray.

The finished battery is wrapped in plastic and palletized. Shipping information and instructions are included with the battery before shipment and a "corrosive" label is attached to all wet (containing electrolyte) shipments.

All East Penn employees are extremely proud of the products that they produce. You can be assured that the highest quality materials and workmanship were used to manufacture your battery.



Fig. I-10



Fig. I-11



Fig. I-9

## SECTION II — BATTERY SAFETY



See P.23 for full warranty information.

### Only trained and authorized personnel should change, repair or charge batteries.

When used properly, a lead-acid motive power battery is a safe, dependable source of electrical power. However, if proper care and safety precautions aren't exercised when handling a battery, it can be an extremely dangerous piece of equipment.

There are four hazardous elements in a lead-acid battery: sulfuric acid, explosive gases, electricity, and weight.

### Hazardous Elements

**Sulfuric Acid:** The electrolyte in a lead-acid storage battery is a diluted solution of sulfuric acid and water. Although the acid content in the solution is only about 37%, it's still a strong corrosive agent and can burn skin and eyes and eat holes in many types of fabric. (See Wearing Protective Clothing.)

Specific Gravity Reading	% Acid Content by Weight
1.280	37.40
1.290	38.55
1.325	42.50

**Explosive Gases:** When a lead-acid battery is being charged, it produces an explosive mixture of hydrogen and oxygen gases. Make sure that all vent caps are unclogged and securely attached so that any gas is safely vented from the battery. Never smoke, use an open flame or create an arc or sparks on or near a battery without first eliminating explosive gases from the cells you're working on. (See Gas Purging — Section VI.)

**Electricity:** An electric shock hazard exists for persons who contact live parts of batteries when the voltage is over 50 volts. The higher the voltage, the greater the electric shock hazard. In addition, metallic objects coming in contact with exposed cell connectors will cause a short and can become very hot. Even shorts involving a single cell can become hot enough to cause severe burns.

**Weight:** The average lift truck battery weighs more than 2,000 pounds. Obviously it can cause serious injury if it isn't handled carefully during installation, removal or transport. Use proper lifting equipment and techniques at all times.

### Wearing Protective Clothing

When working on or near batteries, always wear proper protective clothes including a face shield, safety glasses, long-sleeved shirt, acid-resistant boots and gloves. Do not wear any metal jewelry because it can short circuit a battery and become extremely hot if it accidentally contacts exposed intercell connectors. Refer to detailed warnings, Section I, Page 5.

### Lifting Batteries

Chain hoists used to handle batteries should be equipped with a non-metallic container or bucket to prevent the chains from dangling and possibly causing a short by coming in contact with exposed intercell connectors on the battery top. If no protection is available, cover the battery with a non-conducting insulating material such as plywood or heavy plastic.

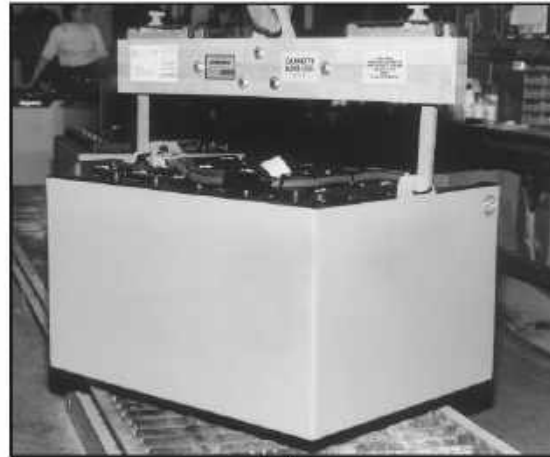

Fig. II-1

Always use the proper lifting equipment to reduce the risk of tray damage, shorting and possible injury. A wood insulated battery lifting beam used with an overhead hoist is the safest way to move a battery (Fig. II-1). An insulated lifting beam, with hooks that fit properly into the lifting ears in the tray, can be used with almost any type of overhead hoist. Be sure the lifting hooks align perfectly with the battery lifting ears. Misaligned hooks can cause battery lifting ear damage and could disengage while the battery is being lifted.

### Using the Battery as a Counterbalance

In order for most lift trucks to operate safely, the battery is used to counterbalance the carried load. Therefore, a new or different battery must fall within the recommended battery weight range. This battery weight information is found on the nameplate of the truck. A battery's service weight is usually stamped on the tray near one of the lifting holes. A battery that's too heavy or too light can change the truck's center of gravity and cause it to be unstable. It's the user's responsibility to be sure that this weight is in the proper range.

## SECTION II — BATTERY SAFETY (cont.)

---

### CHARGING BATTERIES

---

#### ***Charging Areas — Proper Equipment***

All plants should have designated charging areas, especially if they change batteries at the end of each shift. These areas should have proper battery handling equipment including overhead hoists, lifting beams, battery racks and cranes, and the area must be well ventilated.

A source of running water nearby is desirable and a water hose at the filling operation is recommended.

Racks used in the charging area must be insulated to prevent any sparking. The battery rack supports must also be suitably insulated or made of non-conducting material.

The floors in battery and charging rooms should have an acid-resistant coating and be sloped toward a sump. They should always be washed with clean water after an acid spill. The spill should be neutralized with a non-corrosive, water based neutralizing chemical that is user safe and environmentally compliant.

Hand-operated fire extinguishers should be available in all charging areas even if the areas are equipped with automatic sprinkler systems. For information on extinguisher class, size and mounting locations, consult local fire authorities or your insurance carrier.

#### ***Charging Areas — Proper Ventilation***

The charging area must be properly ventilated, either naturally or with a ventilation system. When installing a ventilation system, a number of factors must be considered, including the number and size of batteries being charged at one time and the size, height and air-tightness of the room.

Ventilation is considered satisfactory if the hydrogen concentration doesn't exceed 2% in any one location. Concentrations of more than 4% are explosive and dangerous. A number of instruments, such as combustible gas indicators and flammable vapor indicators, are available for continuous automatic analysis of hydrogen content in the air.

Always keep tray covers and truck compartment covers open when charging a battery. This helps cool the battery and disperse the gases.

#### ***Connecting/Disconnecting Charger***

Always turn the charger OFF before connecting or disconnecting a battery. Live leads can cause arcing and sparking, which could cause an explosion if battery gases are present. In addition, the contact surfaces of the plugs or connectors will become pitted over time.

#### ***Sparks, Open Flames***

Because of the explosive gas mixtures generated while charging batteries, anything that could ignite the gas, such as sparks, open flames, an electrical arc, smoking, etc., must be prohibited in the charging areas. To serve as a prominent reminder, "NO SMOKING" signs should be posted in all charging areas.

### HANDLING ACID

---

#### ***Pouring Acid***

Use a carboy tinter or safety siphon when removing acid from a carboy container. The venting device in a carboy prevents splashing. Carboys should be stored in a cool place away from direct sunlight. (Note: Use proper eye protection, protective clothing and equipment.)

#### ***Mixing Electrolyte***

Mix electrolyte in a heat and acid-resistant container. Always pour acid into water. Never pour water into acid because a violent chemical reaction can occur. Pour the acid slowly and stir the mixture so the acid doesn't settle on the bottom.

When using high specific gravity acid (above 1.400), take special precautions because it can be extremely dangerous. (Note: Use proper eye protection, protective clothing and equipment.)

Store acid and electrolyte solutions in covered containers made of lead, glass or acid-resistant plastic. Keep the containers in a cool, dry area away from direct sunlight.

**Important - only the most experienced battery technicians should be allowed access to sulfuric acid and allowed to add acid for cell equalization purposes.**

#### ***First Aid for Acid Splash***

**Eyes:** Flush immediately with gently running water for at least 15 minutes, then see a doctor as quickly as possible. For contact lens wearers, remove the lens before the eyes are flushed. A buffering or neutralizing agent shouldn't be used in the eyes without the approval of medical or safety personnel.

**Skin:** Wash affected area under running water and apply a chemical burn treatment. Severe burns require immediate medical attention.

**Clothing:** If large areas of clothing have been splashed or soaked, the clothing must be removed and the acid must be neutralized with a non-corrosive, water based neutralizing chemical that is user safe and environmentally compliant and then rinsed under running water. If the clothing is rinsed quickly enough, the chances of damage to the material are lessened.

Acid-resistant boots should always be checked before wearing to be sure that there are no acid puddles inside.

## SECTION II — BATTERY SAFETY (cont.)

### Eye Wash and Emergency Shower Facilities

Emergency eye wash and acid neutralization facilities should be located in the immediate work area for easy access. The three most popular types of eye wash and acid neutralizing equipment are the chemical burn station, deluge shower, and eye wash fountain.



Fig. II-2

1. A **chemical burn station** (Fig. II-2) is used in smaller battery charging and repair areas. The station consists of a wall-mounted plastic squeeze bottle that contains a buffering solution for treating acid burns on skin, eyes and clothing. This inexpensive equipment should be used only where acid with a specific gravity lower than 1.400 is used. A buffering or neutralizing agent shouldn't be used in the eyes without the approval of medical or safety personnel.



Fig. II-3

2. A **deluge shower** (Fig. II-3) should be used where high specific gravity acid (above 1.400) is handled. The shower uses a handle or foot treadle to turn on a powerful water stream that can wash acid from skin and clothes.



Fig. II-4

3. An **eye wash fountain** (Fig. II-4) should be used wherever batteries and/or acid is handled, regardless of the acid's specific gravity. This device produces two streams of water so that both eyes can be flushed simultaneously.

### Neutralizing Acid and Electrolyte

For cleaning batteries, non-corrosive, water based battery cleaning products are all that should be used. For user safety and environmental regulatory compliance, the cleaning liquid should contain no hazardous chemical ingredients. Even some products labeled "Battery Cleaner" must be avoided because of hazardous ingredients and damage to batteries and related equipment.

Acid spills are common in battery rooms. When acid spills occur it is critical to minimize:

1. Health and safety risk to personnel and the environment.
2. Damage to batteries, equipment, and surrounding surfaces.
3. Time to neutralize, absorb, and clean-up.
4. Disposal costs of waste materials.
5. Regulatory compliance risks and fines.

Neutralizing acid absorbers and spill kits have the performance attributes required when dealing with acid spills. The pH neutral dry and non-hazardous waste is easy to sweep-up and dispose as non-hazardous waste.

## SECTION II — BATTERY SAFETY (cont.)

### Repairing Batteries

Keep in mind several safety points when repairing batteries:

1. Never work on a battery while on charge or discharge. Always disconnect it from the charger or truck first.
2. Always remove vent caps before beginning work.
3. Always remove gas from all battery cells before beginning work (see Gas Purging — Section VI).
4. Use caution when melting sealing compound. Melted compound is extremely hot and can cause severe burns if not properly handled (see Sealing Compound — Section VI).

5. To prevent possible short circuits, use insulated tools whenever you are working on a battery. If possible, cover the terminals and connectors with an insulating material such as plywood or heavy plastic, if the battery being worked on does not have intercell connector and terminal shrouds installed.

For more detailed information on safety battery repair procedures, see Section VI — Battery Repair.

## SECTION III — INSTALLATION AND USE

### Receiving a Battery

After receiving a battery, examine the crate and pallet for signs of damage. If you see any wet spots, the battery may have been tipped or damaged during transit. Be careful when handling a crate or packing material that's contaminated with spilled electrolyte. Chemical burns can result if skin or clothing comes in contact with the spillage. Follow the precautions listed under "Handling Acid" — Section II.

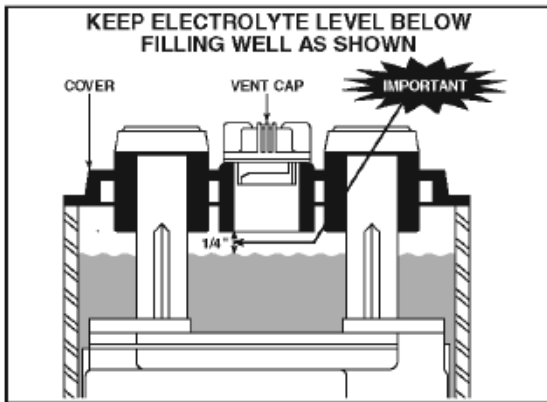

Fig. III-1

Every cell should be inspected to be sure that the electrolyte level is above the moss guard (Fig. III-1). If the electrolyte level is slightly below the moss guard in any cell, it can be raised by transferring a small amount of acid from higher level cells within the battery by using a syringe or hydrometer.

If a large amount of liquid is required to raise the level, the cell jar may be damaged. Inspect the packing material under the tray for signs of leakage. All damaged components should be inspected by your East Penn agent or representative.

Call your East Penn representative immediately. In the meantime, keep the damaged cell's vent cap tightly in place and protect the floor from acid leakage. Do not attempt to discharge or charge the battery.

### Temporary Storage

When it is fully charged and the electrolyte is at the proper level, the battery can be stored for up to a year. It should be stored in a cool, dry, well-ventilated area away from direct sunlight. If the battery must be stored for several months or longer,

Temperature Effect on Specific Gravity of New Batteries Stored on Open Circuit

Temperature (Degrees Fahrenheit)	Maximum Loss of Specific Gravity Per Day
120	.004
100	.003
80	.001
50	.0005

a freshening charge (see "Placing a Wet Charged Battery in Service") should be given whenever the specific gravity falls below 1.240 or every six weeks. If the average storage temperature is below 68°F (20°C), check the specific gravity at least once every two months. If the temperature is above 68°F (20°C), check it every month.

Batteries in steel trays without covers should be covered with a non-conductive material to protect them from dirt, moisture, etc. A flat sheet of rigid plastic or plywood will work well. Do not drape flexible plastic sheeting over batteries because it might trap explosive gases underneath.

Note: If batteries must be stored for more than one year, consult the manufacturer.

### Placing a Wet Charged Battery in Service

Give a freshening charge to a new battery before putting it into service. Charge the battery until the specific gravity and all cell voltages have stabilized. The full charge specific gravity is 1.280 to 1.295 when temperature corrected to 77°F (25°C). Ideally, the battery should be cool; less than 90°F (32°C), when it's installed in the vehicle. Check the manufacturer's specifications for full charge specific gravity on high gravity battery types.

When installing a battery, make sure that the battery compartment is clean, corrosion-free and the ventilation openings aren't obstructed or blocked off.

To lift the battery, use a lifting beam and an overhead hoist (see "Lifting Batteries" — Section II). Set the battery securely in the compartment and block it into position. Some vehicles have adjustable clips for blocking the battery into place. The battery should not be wedged tightly into the compartment because clearance for expansion must be provided. However, clearance can't exceed 1/2" between the block or clip and the battery tray (Fig. III-2).



Fig. III-2

Be sure all vent caps are in place because electrolyte from uncapped cells can corrode the tray and vehicle.

### Placing a Dry Charged Battery in Service

*Note: The activation of dry charged batteries is an involved process which should be handled by trained personnel. For a thorough explanation, refer to East Penn's "Procedure for Activating Dry Charged Industrial Cells and Batteries," which is supplied with every dry charge battery.*

A dry charged battery is a fully charged battery from which all the electrolyte has been removed. Because it's essential to keep these batteries in the dry state until ready for use, they should be stored in a cool, dry, low-humidity area with their vent caps and protector cap and plugs tightly in place until ready for use. When reactivated, install as described in "Placing a Wet Charged Battery in Service."

### Cycling Characteristics

Every time a battery is discharged and then recharged it's called a cycle. An average battery lasts 1,500 to 1,800 cycles, or 5 to 6 years. (Actual battery life depends on battery type, the severity of use, and how the battery was maintained while in service.)

As a battery discharges, the voltage normally drops slowly at first and then more rapidly toward the end of the discharge. Battery temperature, on the other hand, rises during discharge, although the increase isn't as high as it is during charging. The amount of temperature increase depends on ambient temperature, ampere discharge rate, and the amount of heat dissipation (which varies according to battery type).

To obtain maximum service life, batteries should be operated at 115°F (46°C) or lower, and they shouldn't be discharged to below 80% of rated capacity. Frequent over-discharging can drastically shorten battery life.

One way to prevent over-discharging is to be sure that the ampere-hour (A.H.) capacity rating of the battery is high enough for the battery's work load. The battery will over-discharge if its workload exceeds its capacity. For heavy-duty applications, a higher capacity battery — such as East Penn's MAX POWER battery — may solve frequent over-discharge problems. To determine if a higher capacity battery is right for your needs, contact your East Penn agent or representative.

### Operation of the Battery

There are several factors that effect the operation of the battery concerning its ability to deliver capacity and life expectancy. Many chemical reactions are effected by temperature; and this is true of the reaction that occurs in a storage battery. The chemical reaction of a lead-acid battery is slowed down by a lowering of the electrolyte temperature that results in less capacity. A battery that will deliver 100% of rated capacity at 77°F will only deliver 65% of rated capacity at 32°F. See Table 3-1, for specific gravity and on charge cell voltage temperature correction.

### Specific Gravity and On-Charge Cell Voltage Temperature Correction

**EXCESSIVE HEAT** will contribute greatly to reducing battery life by corroding the positive grids and excessive gassing which loosens active material in the plates, especially the positive plate. Over charging is the most common contributing factor to excessive temperatures and gassing in a battery. A properly rated and matched charger will help to avoid the problem of overcharging.

**CONSISTENT UNDERCHARGING** of a battery will gradually run down the cells and result in one or more cells becoming completely discharged before the others, and may become reversed. Capacity and life expectancy are greatly reduced by undercharging. Equalizing charges to return the cells to a normal condition should be part of a weekly maintenance schedule.

**OVERDISCHARGING** can also cause permanent damage to the battery. Recharging is more difficult and more time consuming. Often complete recharge is not attained and the undercharged battery is placed into service. Consequently, it is over discharged to a lower limit resulting in loss of capacity and premature battery failure. Optimum battery life can be aided by limiting the depth of discharge to 80% of its rated capacity.

A good battery maintenance program is necessary to protect life expectancy and capacity of the battery. A more detailed discussion of battery maintenance can be found in Section IV of this manual.

## BATTERY CHARGING

### Basic Charging Facts

Proper charging is essential for maximum battery life. In general, the proper charging rate for lead-acid batteries is any rate which doesn't produce temperature higher than 115°F (46°C), and any rate which doesn't cause excessive gassing.

When a discharged battery is initially placed on charge, it draws a current equal or close to the charger's maximum output. As the battery's voltage rises, the charger output should adjust to the changing voltage to assure a safe, efficient charging rate during all stages of the charge.

With today's automatic start/stop charges, under and overcharging are virtually eliminated. These "smart" charges have computerized control units that can determine when a battery is fully charged and then automatically terminate the charge cycle. For example: The charger delivers a "maximum" start rate of 20 amps per 100 A.H. of rated capacity. As the voltage rises to 2.37 volts @ 77°F (25°C) per cell, the gassing voltage of the battery is held constant until the charge rate tapers down to 5 amps per

## SECTION III — INSTALLATION AND USE (cont.)

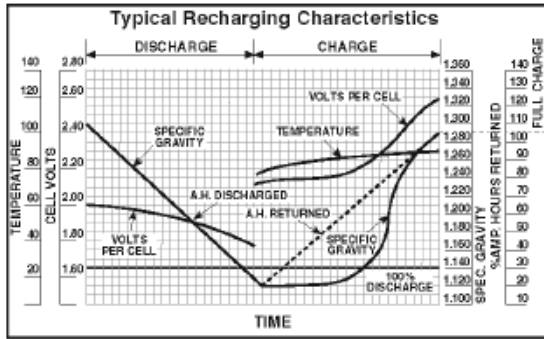

Fig. III-3

100 A.H. This finish rate is held constant until the charger automatically shuts off. Charger start rates should not be more than 20 amps per 100 A.H. of rated capacity, and the finish rates not less than 5 amps per 100 A.H. @ 2.60 V.P.C. (Fig. III-3).

The above requirements will return a discharged battery to full recharge. See your East Penn representative for details. Periodic inspection and adjustment of automatic charges should be done by a qualified electrician.

### Specific Gravity Temperature Correction

Specific gravity measurements are based on a cell temperature of 77°F (25°C). In order to obtain an accurate specific gravity measurement, the hydrometer reading must be adjusted based on the temperature of the electrolyte. A good rule of thumb for temperature correction is to add 4 points of specific gravity (.004) for each 10 degrees Fahrenheit over 77°F and to subtract 4 points for each 10 degrees under 77°F.

See table 3-1 — Specific Gravity Temperature Correction

### Charging Methods

There are two important types of charge that are used for lead-acid Industrial batteries: Standard Recharge (Cycle Charge) and Equalizing Charge. (A third type of charge, the Freshening Charge, is explained in "Placing a Wet Charged Battery in Service").

**Standard Recharge** — After a battery has undergone a normal full shift and has been fully discharged to a recommended 80% of rated capacity, it must undergo a complete, or standard, recharge. Normally, a standard recharge is based on an 8-hour charging cycle.

**Equalizing Charge** — Due to a slight difference in the construction of each battery cell, some cells take less charge than others. An occasional equalizing charge will correct these cell-to-cell imbalances and bring all cells up to the same capacity. An equalizing charge is simply a 3-hour continuation of the standard recharge at no more than the battery's finish rate. A minimum 3 amp per 100 A.H. equalize charge rate is necessary to receive the full benefit of the equalize charge. A lower equalize charge rate will require a longer equalize charge period.

The best way to determine if the battery needs an equalizing charge is to check the specific gravity readings for each cell. If there is more than 0.020 specific gravity unit variation between any two cells, the battery should be equalized. A good rule of thumb is to equalize the battery once each week.

See table 3-2 — Specific Gravity vs. Percent Discharge

Specific Gravity Temperature Corrections			
Electrolyte Temperature		Specific Gravity Correction	On-Charge Cell Voltage Correction
Fahrenheit	Celsius		
130	54	+ .022	+ .18
127	53	+ .020	+ .17
124	51	+ .019	+ .16
121	49	+ .018	+ .15
118	48	+ .017	+ .14
115	46	+ .016	+ .13
112	44	+ .014	+ .12
109	43	+ .013	+ .11
106	41	+ .012	+ .10
103	39	+ .011	+ .09
100	38	+ .009	+ .08
97	36	+ .008	+ .07
94	34	+ .007	+ .06
91	33	+ .006	+ .05
88	31	+ .004	+ .04
85	29	+ .003	+ .03
82	28	+ .002	+ .02
79	26	+ .001	+ .01
76	24	—	—
73	23	-.002	-.01
70	21	-.003	-.02
67	19	-.004	-.03
64	18	-.005	-.04
61	16	-.006	-.05
58	14	-.008	-.06
55	13	-.009	-.07
52	11	-.010	-.08

Table 3-1

### The Charging Process

During the charging process, the sulfate in the battery plates, which accumulated during discharge, is driven back into the electrolyte. This increases the specific gravity and brings the on-charge voltages up to 2.50-2.70 volts per cell, depending on the age of the battery. (See "Discharging/Charging Characteristics" in Section I).

As the battery approaches full charge, the charging rate must be reduced to the battery's finish rate. The finish rate is that current which can be used safely on the battery anytime charging is required, and which can be continued after the completion of the charge without causing excessive gassing or high temperatures. East Penn's official finish rate in amps is equal to 5% of the amp hour capacity at the 6 hour rate. The finish rate is on the nameplate of all East Penn batteries.

Normally, a battery will be properly charged if the charging equipment is in good working condition and the battery is "healthy". A fully charged battery will have the following characteristics while on charge:

- Stable on charge battery voltage
- Gassing freely
- Charger current readings have leveled off to finish rate
- Temperature-corrected specific gravity has stopped rising

See table 3-1 for specific gravity temperature corrections.

**SECTION III — INSTALLATION AND USE (cont.)**

**D and M Series**

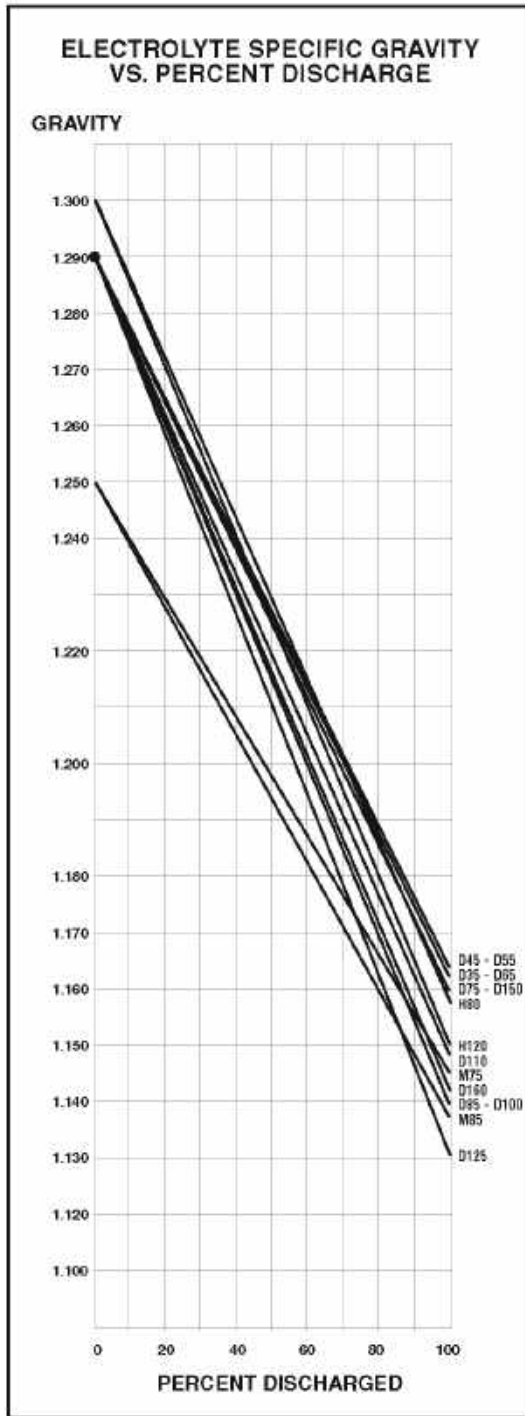

**MAX POWR Series**

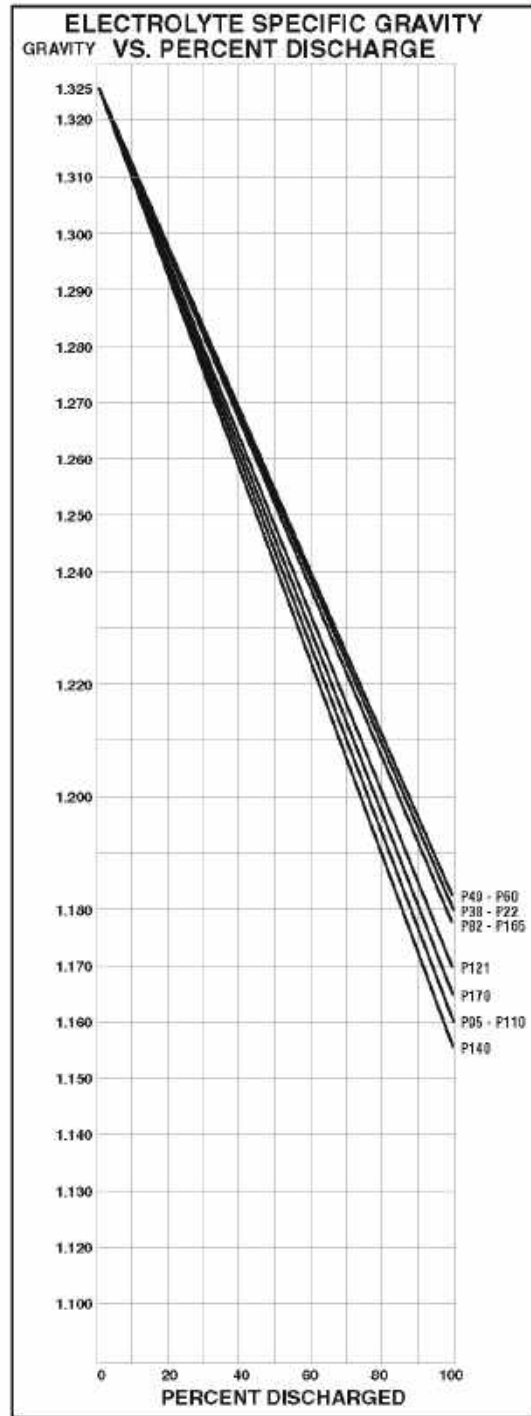

Table 3-2

## SECTION III — INSTALLATION AND USE (cont.)

---

### Improper Charging

Improper charging reduces battery capacity and life.

Undercharging can cause residual sulfation to remain on plates, reducing cell performance. Sulfation also slowly occurs when batteries are stored for months without receiving periodic freshening charges. The cells of a sulfated battery give low specific gravity and voltage readings. It's difficult to bring a heavily sulfated battery back to full charge and doing so will develop high temperatures. (See "Correction of Sulfated Cells" — Section IV).

Undercharging also results in insufficient gassing, which creates a high acid content at the bottom of the cell, eventually leading to sulfation on the bottom part of the negative plates. This condition can be corrected by periodic equalizing charges.

Although all batteries are overcharged to an extent during every charge cycle, severe overcharging results in excessive gassing and very high battery temperatures — both of which are damaging to the battery. Battery temperatures should not exceed 115°F (25°C) during charging.

Excessive gassing occurs when a high charging rate is continued after the battery has been brought to its gassing voltage (2.37 volts per cell nominal). A noticeable bubbling of electrolyte can be seen, accompanied by high electrolyte temperature. Because the gas is released from the electrolysis of water, excessive gassing results in unusually high water usage. (See the Troubleshooting Chart at the end of Section IV for additional causes and remedies.)

For reduced maintenance and long, trouble-free battery life, make sure all your batteries are properly charged. If you're having trouble correcting any problems, contact your East Penn agent or representative.

### Charging Safety

There are several important safety precautions that should be taken when charging a battery:

- Do not use open flames when checking the electrolyte levels in storage batteries.
- Keep all open flames, sparks and matches away from the charging area. DO NOT SMOKE around the charging area.
- Only properly trained personnel should charge batteries.
- Before a battery is removed from a truck, or charged in a truck, the truck's electrical circuit should be open, the battery should be unplugged from the truck, and the wheels should be chocked. (If removing the battery from the truck, be sure to use proper lifting methods and equipment.)
- The charger should be OFF before connecting it to the battery.
- All mechanical connections on the battery and charger should be tight. Loose connections can overheat and cause arcing that could cause a gassing cell to explode, or cables to become hot to the touch.
- Covers on battery trays should be kept open while charging to promote cooling and allow gas to escape. If the battery remains in the truck during charging, keep the battery compartment cover and battery tray cover open.
- Vent plugs should be kept firmly in place at all times to minimize electrolyte spray when the battery gasses.
- The charger should be OFF before disconnecting the battery.
- The charger connector shall not be plugged into the lift truck connector under any circumstances.

## SECTION IV — BATTERY MAINTENANCE AND TROUBLESHOOTING

---

Proper maintenance is essential to obtain long life and maximum efficiency from any Industrial battery. Carefully following a scheduled maintenance routine will help increase battery performance and prolong service life.

One of the keys to an effective battery maintenance program is to maintain an accurate records system of battery cycles and maintenance/repair work for each battery. A records system is particularly important for operations that use a large number of batteries.

If you don't already have one, these procedures should help you create a reliable records system:

1. Assign a code/identification number to each battery and charger. Use a multiple digit-system if you have several different sizes or types of batteries. Prefixes or suffixes can be used to identify batteries by size, voltage, shift, lift truck, etc.
2. Designate a "pilot cell" for each battery. Record the specific gravity, voltage and temperature of the pilot cell when the battery is first received and equalized, and before and after each charge. The readings taken on the pilot cell are considered to represent the specific gravity, voltage and temperature of all the cells. **Always** use the same cell for the pilot cell. The pilot cell should be positioned near the center of the battery and can be identified with a marking of some sort on the intercell connector shroud or cell cover.
3. At least once each month, measure and compare the specific gravity of all the cells. The readings should be uniform from cell to cell. If the specific gravity readings fall 20 points (0.20) below the nominal specific gravity reading of 1.290, the electrolyte levels should be checked and brought up to a uniform level before checking for a second time. If, at any time, the readings are 20 points (.020) greater than the nominal specific gravity readings of 1.290, or the range of the on-charge cell voltage readings is more than 0.15 volts, the battery could be showing signs of cell failure. Contact your authorized Deka Service Representative.
4. Remember to accurately record the number of cycles, specific gravity, temperature and voltage readings; and all maintenance and repair information for every battery. THE DAILY BATTERY RECORD (Fig. IV-1) is an example of a basic record-keeping form. You should use a form that best fits your operation's individual needs. It is also recommended that the identification number of the charger used to charge the battery be recorded.



## SECTION IV — BATTERY MAINTENANCE AND TROUBLESHOOTING (cont.)



Fig. IV-3

Always record basic data gathered during routine inspections. The first step is to visually inspect the battery.

### Look for:

- Corrosion on the tray, terminals or intercell connectors.
- Leaks or damage to the tray.
- Damaged cable leads, terminals or connections.
- Damaged, clogged or missing vent caps.

Repair or replace any damaged parts (see Section V — *Battery Repair*) and thoroughly clean the battery. (Battery cleaning is covered in detail later in this section.) In case of serious damage or for major repairs, contact your nearest authorized East Penn representative.

Before taking any specific gravity or voltmeter readings, the battery should be fully charged, but then placed on charge again and allowed to charge for a minimum of 15 minutes. Take specific gravity and voltage readings for each cell and record the readings on your battery inspection form. Use the battery's positive terminal cell as cell #1 and follow the intercell connectors to the last cell (the battery's negative terminal cell). Look for any unusual readings that might indicate a problem cell.

### Adding Water/Adjust Electrolyte Levels

Batteries normally lose a certain amount of water due to evaporation and electrolysis during charging. It's very important not to allow the electrolyte level in any cell to drop below the top of the separator protector, since low levels can damage the plates and shorten life. It's equally important to avoid overfilling the cells, as electrolyte will be forced out of the vent caps during charging onto the top of the battery, causing tray corrosion and reducing battery capacity.

Only approved water should be used to water cells because certain impurities and chemicals found in tap water can be harmful to batteries. Tap water in certain areas of the country is unsuitable at any time, while in other areas it may be satisfactory only during certain seasons. If the water in your area isn't suitable, use distilled or de-ionized water. The National Electrical Manufacturers Association (NEMA) standards for maximum allowable impurities are:

Total Solids	350 PPM (parts per million)
Chlorides and Cl <sup>-</sup>	25 PPM
Nitrates as NO <sub>3</sub>	10 PPM
Iron as FE	4 PPM

If you have any doubts about the suitability of your water, contact your local authorized Deka Representative who can arrange to have a water sample sent to East Penn's lab for analysis, for a nominal fee.

Water should only be added to batteries while the batteries are on charge and gassing or as soon after recharge as possible. This will prevent overfilling because the electrolyte is at its maximum level during this time. To prevent low electrolyte levels, frequent checks should be made and water should be added when necessary.

The electrolyte level should be maintained between the low level at the perforated separator protector and the high level at the bottom of the vent well opening of the cover. The manufacturer's specific gravity recommendations always are determined with the electrolyte at the high level.

How a watering schedule is determined depends on the type of battery, frequency of charge, temperature of the battery, and age and condition of the battery. Excessive water loss may be caused by shorted or weakened cells, excessive charging rates, or the charger not shutting off automatically. Cells that continually lose excessive amounts of water should be checked for possible internal damage.

### Battery Cleaning Wash Unit

A well maintained battery is a clean battery. Routine cleanings should be done once a month on the average, to prevent tray



Fig. IV-4

corrosion and help keep the battery operating at peak efficiency. More frequent cleaning may be needed if batteries are being operated in a very dusty or dirty environment.

For general cleaning, use a non-corrosive, water-based battery cleaner. For user safety and environmental regulatory compliance the battery cleaner should contain no hazardous chemical ingredients.

The Deka Battery Cleaning System, is a state-of-the-art process that completely cleans and neutralizes batteries, while safely processing the wash water to meet EPA and DOT requirements. No contaminants are discharged into water supplies or the soil; all materials in the treated wash water are completely encapsulated and removed from the facility. Contact your East Penn representative for more detailed information.

Most batteries have intercell connectors and terminals covered

## SECTION IV — BATTERY MAINTENANCE AND TROUBLESHOOTING (cont.)

with plastic shrouds. These should be removed prior to battery cleaning and immersed in the cleaning solution.

**MAKE SURE ALL VENT PLUGS ARE TIGHTLY IN PLACE WHEN CLEANING OR WASHING BATTERIES.** Check the gas escape holes in the vent plugs for dirt clogs.

For maximum effectiveness, the solution should be applied with a clean, non-metallic brush, so it can be worked under the terminals and intercell connectors to remove dirt and neutralize any excess acid (Fig. IV-4). Use a low pressure hose to rinse the battery with water until all traces of solution and loose dirt are removed.

Before placing the cleaned battery back in service, rinse and attach the intercell connector and terminal shrouds. All excess rinse water should be removed from the battery top with a low pressure air hose or allowed to air dry.

### Performing a Test Discharge

To determine if a battery can deliver its rated capacity, a test discharge, or capacity test, can be performed. This test helps determine the "health" of a battery and whether or not it should be replaced.

Only experienced battery technicians should be allowed to prepare a battery for discharge testing and to conduct the actual discharge test.

The test is conducted by discharging a fully charged battery at the six hour rate until the battery voltage drops to a final voltage of 1.70 volts per cell, times the number of cells in the battery. The six hour rate in amps is a number equal to the rated capacity at the six hour rate divided by six hours.

By noting the time elapsed between when the battery was put on discharge and when the final voltage was reached, you can determine whether the battery is delivering its rated capacity:

1. Give the battery an equalizing charge and adjust the specific gravity to the manufacturer's specification, with the electrolyte level at the bottom of the vent well. Always temperature correct the gravity readings.
2. Start the test and record the starting time.
3. Record individual cell voltages and overall battery voltages during the first hour at 10 minutes, 30 minutes and then 60 minutes. After the first hour, take hourly readings until the first cell voltage reaches 1.75 volts per cell. From this point on, record the voltage of the cells every 5 minutes.
4. Carefully monitor the voltage of the low cells and as the voltage of each cell drops below termination value, record the time.
5. When the majority of the cells reach termination value, stop the test. Don't let any cells go into reversal.
6. Use this formula to calculate capacity delivery:

$$\frac{\text{minutes to final voltage}}{360 \text{ minutes} \times 100}$$

For example, if the test was terminated after 336 minutes, the capacity percentage would be 93%

7. After termination of the test, immediately record the specific gravity of each cell. If all the cells have uniform specific gravity and the battery delivers 80% or more of its rated capacity, 288 minutes, it can be returned to ser-

vice. If the test indicates that less than 80% of the battery's rated capacity is being delivered, the battery should be either repaired or replaced, depending upon its age and overall condition.

For more detailed information on capacity testing, contact East Penn Manufacturing Company or your local authorized Deka Representative.

### Correcting a Sulfated Battery

If batteries are not operating full shifts, heat while on charge and after charge, and if temperature corrected specific gravity readings are below the manufacturer's specifications, the batteries may be sulfated.

To restore a sulfated battery to good condition, carefully follow this procedure:

1. Thoroughly clean the battery.
2. Add water to bring the electrolyte to the proper level in all cells.
3. Charge the battery at the prescribed finishing rate until the specific gravity shows no change for a three-hour period with readings taken hourly. Record on-charge voltage and specific gravity readings. Temperature correct the specific gravity readings using the chart (Table 3-1) in Section III. If the temperature rises to above 115°F (46°C) at any time, stop the charger and allow the battery to cool to 90°F (32°C) or lower, then continue the charge and monitor the specific gravity as described above. If the charger is automatic, be sure it is capable of charging the battery at the prescribed finish rate. A constant current charger that can maintain the correct finish rate is preferred. If the battery is badly sulfated, the specific gravity may only rise 30 to 40 points (0.30 to 0.40) during the first charge.
4. Fully discharge the battery.
5. Repeat step #3 until the specific gravity remains unchanged for three hours. In extreme cases of sulfation, two or more discharges and recharges, per the above instructions, may be necessary to restore the battery to full capacity. (Percent capacity capable of being restored is a function of overall battery age and condition). If the battery hasn't responded, it may be sulfated beyond repair and should be replaced. If the specific gravity rises to within ten points of a fully charged battery, then place the battery back into normal service.
6. Before condemning the battery, one last check should be made to make sure the battery has not simply lost acid by dumping or over-filling. Adjust the specific gravity to the manufacturer's specification (see Table 4-1 - Procedure for Adjusting the Specific Gravity of the Electrolyte of a Battery).

Conduct a capacity test. If the battery delivers over 90% of its rated six hour capacity, the battery may be returned to service. If the capacity on discharge remains low, the battery should be replaced.

**IMPORTANT** - Only experienced battery technicians should perform the above technique.

## SECTION IV — BATTERY MAINTENANCE AND TROUBLESHOOTING (cont.)

**Table 4-1**

**PROCEDURE FOR ADJUSTING THE SPECIFIC GRAVITY  
OF THE ELECTROLYTE OF A BATTERY**

1. When it is necessary to raise or lower the specific gravity of the electrolyte of a battery to the manufacturer's recommended specific gravity, follow the procedure given below.
2. The recommended specific gravity for some of the Deka industrial battery styles is shown in Table 1. For example, a 12-D85-13 battery would have a recommended specific gravity of 1.290.
7. Care should be taken during equalizing charging and acid adjustment charging to make sure that the electrolyte temperature does not exceed 115°F.
8. As it is necessary to add acid to the cell in order to raise the specific gravity of the electrolyte, sulfuric acid of 1.400 specific gravity shall be used. It should be remembered that 1.400 specific gravity sulfuric acid has an acid content of 50.5% by weight and is potentially a very dangerous material to the person using it. All standard safety precautions should be taken, especially those which will protect personnel from splashes into the eyes and onto the skin. Acid resistant gloves, apron, boots, face shield and /or goggles should be standard equipment. Running water from a hose and/or ready access to an eye-wash fountain is important for safety.

**TABLE I**

Battery Style or Type	Recommended Specific Gravity at 77°F
D prefix	1.290
H prefix	1.300
M prefix	1.250
P prefix	1.325
DL/DLU	1.250

3. This specific gravity is always determined when the battery is fully charged, with the electrolyte level at the bottom of the vent well tube while the battery is on charge at the finish rate or less.
4. The term "finish rate" refers to a constant charging rate in amps which is equal to 5% (.05) of the rated six hour capacity (8 hour for diesels) of the battery. For example, the finish rate of a D100-13 battery with a rated 6 hour capacity of 600 AH (ampere hours) would be:  $600 \times .05 = 30$  amps.
5. The battery should first be given an equalizing charge to make sure it is fully charged. An "equalizing charge" is an extended charge at the finish rate after completion of a regular charge. Usually 3 or 4 hours until four voltage and specific gravity readings, corrected for temperature, taken 1/2 hour apart, remain constant.
6. Since the electrolyte temperature will affect the on-charge voltage and specific gravity readings, all readings must be corrected for temperature to a standard 77°F. Refer to Section III, Table 3-1, Specific Gravity Temperature Corrections.
9. With the battery on charge at a constant finish rate, remove between a 1/4" to 1/2" of electrolyte with a syringe for every 5 points of change required. This is only a rough approximation since the amount of change will vary with every cell type with a greater change on the shorter cells and a smaller change on the taller cells. Replace the electrolyte removed with 1.400 specific gravity sulfuric acid. Continue to charge the battery after acid addition until the specific gravity becomes constant, about 1/2 to 1 hour.
10. Repeat the above procedure until the specific gravity of the electrolyte, corrected for temperature, reaches the desired value.
11. If the specific gravity must be lowered instead of raised, water can be used instead of 1.400 specific gravity acid in the procedure given above.

**SECTION IV — BATTERY MAINTENANCE AND TROUBLESHOOTING (cont.)**

**Table 4-2**  
STORAGE BATTERY TROUBLESHOOTING CHART

Symptoms	POSSIBLE CAUSE	POSSIBLE REMEDY
Battery overheats during charge	1. Malfunctioning Charging Equipment	1. Replace or repair defective charger parts (timer, voltage sensitive relay, control board, etc.)
	2. Charging equipment out of adjustment	2. Adjust start and/or finish charging rates
	3. Defective or weak cell(s)	3. Replace or repair problem cell(s)
	4. Battery worn out and beyond economical repair	4. Replace battery
	5. High resistance connection within battery	5. Check for hot wires, cells, intercell connectors, charging plugs, etc. Repair or replace defective component(s)
	6. Low electrolyte level	6. Add water; just cover separator protector when discharged
	7. Battery charged in the vehicle with battery compartment closed or the tray cover closed	7. Open the compartment during charge or charge the battery out of the unit with the tray cover opened
	8. Battery over 100 degrees F when placed on charge	8. Allow battery to cool below 90 degrees F before charging
Battery overheats during charge	1. See causes 3 through 8 above	1. See remedies 3 through 8 above
	2. Worn out bearings, brakes dragging, or other vehicle problem causing high discharge rates	2. Repair or replace defective unit problems
	3. Overdischarge of battery	3. a. Require drivers to return battery for recharge when vehicle begins to slow down. b. Put more batteries into service
Battery not completing full work shift	1. Battery not fully charged before placed into operation	1. See that battery has reached full charge specific gravity before placing into operation
	2. Weak, leaking or defective cell(s) in battery	2. Repair or replace cell(s) or battery
	3. Ground or shorts in the battery	3. Remove grounds or shorts
	4. Battery worn out and beyond economical repair	4. Replace battery with equal or higher capacity battery
	5. Battery too small for job	5. a. Replace battery with one having higher capacity b. Purchase extra batteries (with higher capacity if possible) and change them more frequently
	6. Electrical or mechanical problem	6. Troubleshoot vehicle and repair

**SECTION IV — BATTERY MAINTENANCE AND TROUBLESHOOTING (cont.)**

*Table 4-2 – Cont.*

<b>Symptoms</b>	<b>POSSIBLE CAUSE</b>	<b>POSSIBLE REMEDY</b>
Low electrolyte	1. Cracked or broken Jar(s) (Look for electrolyte puddles on floor)	1. Replace jar(s) and adjust gravity
	2. Cell missed when watered	2. More careful attention when watering
	3. Defective or weak cell(s)	3. Repair or replace cell(s)
	4. Frequent overcharge	4. See items 1 and 2 in "Battery Overheats During Charge"
	5. Battery not regularly watered	5. Water battery regularly
Unequal cell voltages	1. Grounds in battery	1. Clean battery
	2. There is a "tap" off the battery for auxiliary equipment (radio, light, etc.)	2. a. Use dropping resistor instead of tap b. Equalize battery regularly
	3. Battery sluggish due to lack of work	3. Give battery a deep discharge and equalizing charge
	4. Leaking cell or cover	4. Replace jar or cover and adjust gravity
	5. Defective or weak cell(s)	5. Repair or replace defective cell(s)
	6. Battery worn out and beyond economical repair	6. Replace the battery
	7. Acid loss in few cells by tipping battery over	7. Adjust specific gravity

## BASIC RULES FOR BATTERY CARE AND MAINTENANCE

**RULE 1: BE CAREFUL! ALWAYS WEAR FACE SHIELD OR SAFETY GLASSES WHEN WORKING ON OR NEAR BATTERIES!**

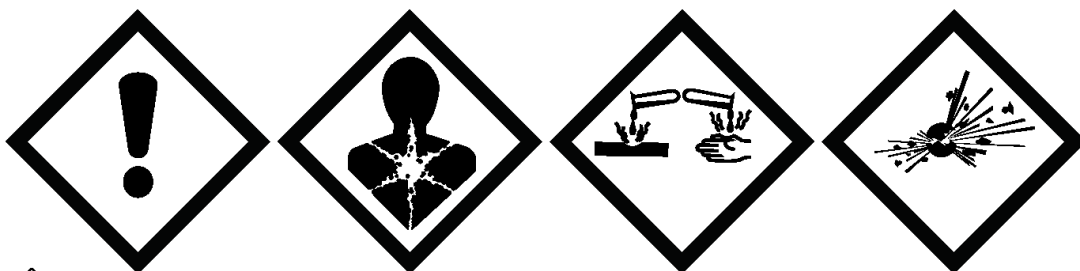

**DANGER** Contains: **Lead, Sulfuric Acid (Electrolyte), Lead Compounds.**

Harmful if swallowed, inhaled, or in contact with skin. Acid causes severe skin burns and eye damage. May damage fertility or the unborn child if ingested or inhaled. May cause harm to breast-fed children. May cause cancer if ingested or inhaled. Causes skin irritation, serious eye damage. Contact with internal components may cause irritation or severe burns. Causes damage to central nervous system, blood and kidneys through prolonged or repeated exposure if ingested or inhaled. Irritating to eyes, respiratory system, and skin. May form explosive air/gas mixture during charging. Extremely flammable gas (hydrogen). Explosive, fire, blast or projection hazard.

Obtain special instructions before use. Do not handle until all safety precautions have been read and understood. Wash thoroughly after handling. Do not eat drink or smoke when using this product. Avoid contact during pregnancy/while nursing. Wear protective gloves/protective clothing, eye protection/face protection. Use only outdoors or in a well-ventilated area. Avoid contact with internal acid. Do not breathe dust/fume/gas/mist/vapor/spray. Keep away from heat/sparks/open flames/hot surfaces. No smoking. IF SWALLOWED OR CONSUMED: rinse mouth. Do NOT induce vomiting. Call a poison center/doctor if you feel unwell.

IF ON CLOTHING OR SKIN (or hair): Remove/take off immediately all contaminated clothing and wash it before reuse. Rinse skin with water/shower. IF INHALED: Remove person to fresh air and keep comfortable for breathing. Immediately call a POISON CENTER or doctor/physician. IF IN EYES: Rinse cautiously with water for several minutes. Remove contact lenses, if present and easy to do. Continue rinsing. If exposed/contaminated, or if you feel unwell seek medical attention/advise. Store locked up, in a well-ventilated area, in accordance with local and national regulation. Dispose of contents/container in accordance with local and national regulation. Keep out of reach of children.

**PROPOSITION 65 WARNING:** Battery posts, terminals and related accessories contain lead and lead compounds, chemicals known to the State of California to cause cancer and reproductive harm. Batteries also contain other chemicals known to the State of California to cause cancer. **WASH HANDS AFTER HANDLING.**

**WARNING:** Risk of fire, explosion or burns. Do not disassemble or incinerate. Not recommended for inverted use. Follow product charging instructions. **High Voltage:** Risk of shock. Do not touch uninsulated terminals or connectors.

**Keep Vent Caps Tightly in Place**

**Manufactured by:**  
East Penn Manufacturing Co.  
102 Iloka Road,  
Lyon Station, PA 19356  
610-682-6361 USA

**Lead Acid  
Battery  
Electrolyte  
(Sulfuric Acid)**

### PROVIDE ADEQUATE VENTILATION WHEN CHARGING

**RULE 2: Keep battery tops clean and dry.**

**RULE 3: Check battery electrolyte level weekly.**

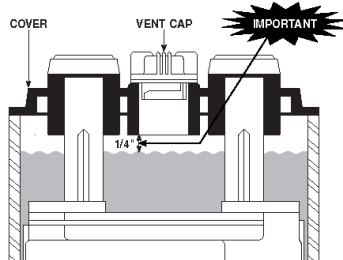

**KEEP ELECTROLYTE LEVEL BELOW FILLING WELL AS SHOWN**

Add approved water to 1/4" below vent well only at the end of charge. Filling to this level before charging will cause acid overflow. Acid attacks external battery parts. Any acid loss from the battery will result in power loss and shortened life.

**RULE 4: Make sure charger is OFF before connecting or disconnecting the battery to prevent dangerous sparks.**

**RULE 5: Use proper size charger and follow charger instructions carefully.**

**RULE 6: Recharge FULLY after each duty cycle. Avoid partial recharging.**

**RULE 7: Remove vent caps only when checking or filling. KEEP CAPS ON when battery is in use, on charge and when cleaning battery top.**

**RULE 8: Batteries with steel covers should be recharged with covers in the open position.**

**RULE 9: Be careful...first and last.**

Fig. IV-1

## SECTION V – VALVE REGULATED LEAD-ACID BATTERIES



Fig. V-1

In the lead-acid battery, according to basic electrochemical principals, complete sealing cannot be accomplished because the generation of hydrogen cannot be completely avoided. The valve has to open periodically to let small amounts of gas, mainly hydrogen, escape from the cell. Otherwise, the internal pressure would exceed tolerable limits. Gradual water loss is connected with this gas evolution, and this water loss causes slight changes in the cell parameters during service life. But the rate of water loss can be kept so low that the initial amount of electrolyte is sufficient for a service life of five years or more.

Valve-regulated lead-acid batteries can be constructed using gelled electrolyte as well as absorbent glass mat separators (AGM). Which immobilizing method is used, often depends upon the application and manufacturer. For deep cycle applications such as motive power, gelled electrolyte is more suitable. The gelled electrolyte requires a separator to prevent short-circuits between the electrodes. This additional separator causes additional resistance. Therefore, the internal resistance of comparable batteries is slightly higher with gelled electrolyte, thus such batteries are not as suitable in extreme high load current with short duration requirements such as UPS applications.

### Operation of a Gel Cell

During the overcharge period of the recharge, oxygen is generated from the positive plates in all lead-acid batteries. This oxygen is trapped in the gel cell by a special vent valve forcing the oxygen to the negative plate through tiny fissures or cracks in the gelled electrolyte. When the oxygen contacts the negative active mass (sponge lead), it oxidizes the negative active mass to lead oxide. The lead oxide reacts with the sulfuric acid to form lead sulfate and water. At the same time, during the charging process, this lead sulfate is converted back to sponge lead and sulfuric acid. This "recombination" process prevents water loss.

The vent valve is critical to the performance of the gel cell. The cell must maintain a positive internal pressure. Otherwise, the oxygen will escape, and the cell will dry out and not perform.

In addition the valve must safely release any excess pressure that may be produced during overcharging, or else the cell would be irreparably damaged.

It's important to note that a gel cell must never be opened once it leaves the factory. Opening the cell will allow excess atmospheric oxygen to enter the cell and discharge the negative plates. This will cause an imbalance that will destroy the recombination chemistry. This imbalance of chemistry will permanently damage the cell beyond repair.

### Charging a Gel Cell

While our gel cell will accept a charge extremely well due to its internal resistance, any battery will be damaged by continual under- or overcharging. Capacity is reduced and life is shortened.

Abusive overcharging is especially harmful to gel cells because of their sealed design. Abusive overcharging dries out the electrolyte by driving the oxygen and hydrogen out of the battery through the sealing vents. Performance and life are reduced.

If a battery is continually undercharged, a power-robbing layer of sulfate can build up on the positive plate, which acts as a barrier to electron flow. Premature plate shedding can also occur. Performance is reduced and life is shortened.

Therefore, it is critical to use a charger that limits voltage to 2.55 volts per cell at  $77^{\circ}\text{F} \pm 2^{\circ}$  at the end of charge. If the charger can reduce the voltage as the temperature rises, or increase the voltage as the temperature decreases, this will help to prevent under- or overcharging. The warranty is void if improperly charged. The supplied on board charger for Gelmate, or the Ultra Charger with the D.S.G. Sealed Lead-Acid Battery charge curve profile, or any other EPM-approved motive power gel cell charger must be utilized to recharge gel cell batteries. Constant current charges or ferroresonant charges should NEVER be used on gel cell batteries. (See Fig. V-2).

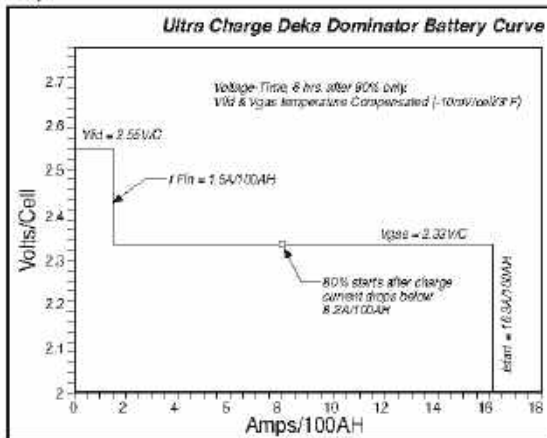

Fig. V-2

## **OPERATING INSTRUCTIONS**

### **SEALED VALVE REGULATED LEAD ACID (SVRLA) GELLED ELECTROLYTE BATTERIES**

**WARNING:** *Charging shall be performed by using only the supplied on-board charger for Gelmate, or the Ultra Charge Charger with the D.S.G. Sealed Lead-Acid Battery charge curve profile, or any other EPM-approved motive power gel electrolyte charger.*

*The valve-regulated vent should not be removed. Removal of the vent will adversely affect the battery's life and performance.*

*The battery's warranty will be void if these guidelines are not followed.*

1. Upon receipt of the battery, if there are signs of rough handling, or exposed electrolyte, or loose or missing vent(s), file a claim with the carrier and advise your East Penn representative.
2. Check the nameplate of your charger against the nameplate of the battery to make sure they both show the same voltage and that the six-hour ampere hour capacity of the battery falls within the recharge range of the charger.
3. The "Battery Type Identification" shown on the battery (E, EO), should match the "Battery Type Identification" specified on the truck nameplate.
4. Make sure that the battery "SERVICE WEIGHT," which is stamped below the lifting hole in the steel tray, falls within the battery weight range shown on the truck nameplate. East Penn Manufacturing Co., Inc. cannot be responsible for determining that the battery weight is sufficient to counterbalance your particular truck.
5. The battery should receive an equalizing charge prior to placing the battery into service. The battery shall be charged by using the supplied charger. The equalizing charge is complete when the charger automatically terminates. No other charger should be used unless approved by East Penn. Doing so will void the warranty. If the voltage falls below 2.14 volts or at a minimum of every 6 weeks the battery should receive a freshening charge.
6. The battery shall be placed on charge at the end of the work shift and the charge should continue until the charger terminates the charge automatically. All vents should be unobstructed and securely tightened. The steel tray cover or the truck compartment should be kept open during the entire duration of charge.
7. Overcharging and undercharging a sealed gel electrolyte battery will greatly affect the life of the battery.
8. Measuring the open circuit voltage provides a way to determine the state of charge of the battery. The open circuit voltage shall be taken with a voltmeter. Voltage measurements should be taken no earlier than 4 hours on open circuit following a charge.

#### **STATE OF CHARGE VS. OPEN CIRCUIT**

<b>% Charge</b>	<b>Open Circuit Voltage</b>
100 .....	2.15 – 2.18
75 .....	2.12
50 .....	2.07
25 .....	2.01
0 .....	1.97

9. EPM recommends when lifting a battery that an insulated lifting beam be used. Also, make certain that the lifting hooks are the correct size and are properly aligned with the holes in the lifting ears of the tray prior to hoisting a battery.

## **MAINTENANCE INSTRUCTIONS**

### **SEALED VALVE REGULATED LEAD ACID (SVRLA) GELLED ELECTROLYTE BATTERIES**

***WARNING: Always wear safety glasses when working around batteries!  
Keep sparks and flames away! The valve regulated pressure relief valve should never be removed or loosened!***

1. The top of the battery should be kept clean and dry at all times. Simply clean the top of the battery with a damp cloth. The valve regulated vent and shroud shall remain on the battery at all times.
2. The cables and connectors should be inspected monthly for exposed copper wires, frayed or cracked insulation, loose connections, or pitted contacts, and repaired as required.
3. Be especially careful to keep metallic objects off the top of the battery. Any metal touching two or more connectors may cause a short circuit resulting in an arc or spark which ignite battery gasses explosively.
4. The output rate and voltage of the charger should be checked periodically. Make certain that the DC voltage and ampere hour range of the charger match the nameplate information on the battery.
5. Depending on the type of service, it will be necessary to give the battery an equalizing charge every one to four weeks. Set the charger to the equalize position.

<b>Type</b>	<b>Plates per Cell</b>	<b>5</b>	<b>7</b>	<b>9</b>	<b>11</b>	<b>13</b>	<b>15</b>	<b>17</b>	<b>19</b>	<b>21</b>	<b>23</b>	<b>25</b>	<b>27</b>	<b>29</b>	<b>31</b>	<b>33</b>
<b>G45</b>	6 Hr. A. H. Rating	—	—	180	225	270	315	360	405	—	—	—	—	—	—	—
<b>G75</b>	6 Hr. A. H. Rating	150	225	300	375	450	525	600	675	750	825	900	975	1050	1125	1200
<b>G105</b>	6 Hr. A. H. Rating	—	—	—	525	630	735	840	—	—	—	—	—	—	—	—

## SECTION VI — BATTERY REPAIR

### Repair or Replace?

It can be difficult to decide if a battery is worth repairing or if it should be replaced. When you have to make this decision, the most important things to consider are the battery's age, cycle life and service history.

If the battery is only 1 or 2 years old (300 - 600 cycles), if it hasn't been severely overcharged or overdischarged, and if the estimated repair costs don't exceed 25% of the replacement cost, then it should probably be repaired.

On the other hand, if a battery has been on the job 3 or more years (900 or more cycles) or has extensive damage, requiring repairs totalling 25% or more of the replacement cost, it should probably be replaced.

**CAUTION: ONLY EXPERIENCED PERSONNEL SHOULD ATTEMPT BATTERY REPAIRS!**

If you don't have an experienced battery repair person, send the battery to your nearest authorized East Penn battery repair facility or arrange to have an East Penn service technician perform the repairs at your plant site. **BEFORE PERFORMING ANY REPAIRS, REMOVE THE BATTERY FROM THE LIFT TRUCK. ALWAYS WEAR SAFETY GLASSES AND A FACE SHIELD WHEN WORKING ON OR NEAR BATTERIES.**

### Gas Purging

Before beginning cell/jar replacement, remove the vent caps from the damaged cell and all surrounding cells and give trapped gas time to dissipate. Flush any remaining explosive gases out of the cell by fanning the vent well opening with a stiff piece of plastic or cardboard. Do not use compressed air as the force of the air stream may splash electrolyte out of the cell and into the face or eyes (Fig. VI-1).

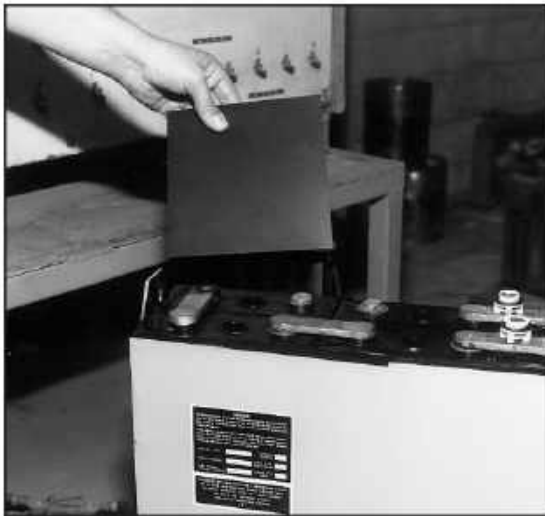

Fig. VI-1

After all the gas has been removed, cover the vent holes or the SVLRA valve/vent with a damp cloth and continue with the repairs.

### Removing Connectors

To remove a complete cell (jar, element and cover) from a battery or to remove an element from a jar, you first have to take off the intercell connector shrouds from the cell(s) being removed. Then remove the intercell connectors, connecting those cells to the rest of the battery, with a drill. Use a special East Penn post saver drill, which will drill through the connector but leave the center of the post in place (Fig. VI-2).



Fig. VI-2

Be careful that lead curls from the drilling don't cause short circuits or drop into neighboring cells. After drilling is completed, lift connector off with a pair of pliers.

### Removing a Cell

The vast majority of batteries being manufactured today incorporate a heat bonded cover-to-jar seal. The cover and jar material is polypropylene. This design is easily distinguishable because the vent well lip is almost flush with the top of the cover.

A few manufacturers continue to use the older compound cover-to-jar seal. The cover is a hard rubber material and can be identified by the very high vent well lip. The cover sets down inside of the jar and the seal is made with a hot asphalt material.

If the battery being repaired has the older cover-to-jar asphalt seal, proceed as follows. After all connectors have been removed from the cell, separate the cell from the tray and from the surrounding cells by cutting through the sealing compound with a warm putty knife or similar tool. (Fig. VI-3). Work the tool down to the cover/jar seal. When all sealing compound has been removed around the cell, attach post lifters to the negative posts and use a block and tackle or a lifting beam to lift the cell from the battery (Fig. VI-4). Never lift a cell or an element by the positive posts. Always use the negative posts.

## SECTION VI — BATTERY REPAIR (cont.)



Fig. VI-3

Once the cell has been removed, inspect the jar for leakage and replace it if necessary. Be sure to clean the tray bottom and side area before replacing the cell. Neutralize any acid or corrosion (see Neutralizing Acid and Electrolyte — Section II) and scrape off any residue.



Fig. VI-4

If removing a heat bonded cover-to-jar designed cell, it is important to note that some manufacturers add a compound pour between cells and the tray edge, in addition to the heat bonded cover-to-jar feature. If the battery being repaired has the compound pour, proceed as explained in this section for the compound cover-to-jar seal design. If the heat bonded cell is in a battery without the additional compound pour, simply proceed to remove the cell as instructed in this section without having to remove the compound seal.

### Removing an Element

If the jar is known to be serviceable, it may not be necessary to remove the complete cell. Usually only the element, complete with cover, has to be pulled. This can only be done however, on those batteries containing a compound type cover-to-jar seal. On these, after removing intercell connectors, draw a warm putty knife through the sealing compound close to the inside jar wall. Use the post lifters and hoist to raise the element, with cover in place, first to drain position, and then up and out of the jar.

When pulling an element from a cell which has been removed from a battery, use jar hold-down clamps.

The most common type of cover-to-jar seal is a heat bonded or seal design. The bottom perimeter surface of the cover and top perimeter surface of the jar are simultaneously melted, then fused together by a heat sealing machine. With this design, if an internal cell defect occurs, the complete cell must be pulled and cover-to-jar seal cut or sawed to permit removal of the ele-

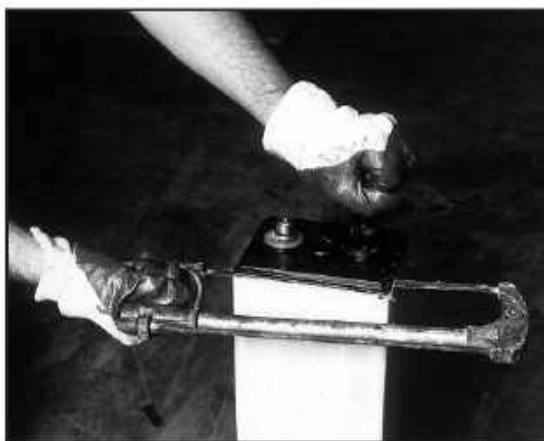

Fig. VI-5

ment (Fig. VI-5). If care is taken in cutting the cover-to-jar seal, these components can be used again when reassembling the cell. Otherwise both a new cover and jar may be needed to complete the reassembly.

## SECTION VI — BATTERY REPAIR (cont.)

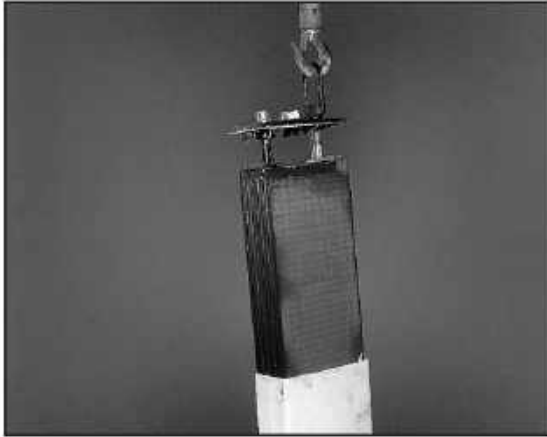

Fig. VI-6

When removing an element, lift it halfway out of the jar and hold it at this position until most of the electrolyte has drained off (Fig. VI-6). Then raise the element to clear the top of the jar. Do not, unless absolutely necessary, expose an element to air longer than five minutes. Oxygen in the air combines with the active material in the negative plates, causing them to oxidize and heat. If the exposure persists, negatives will discharge. While the element is out of the jar, check the sediment chamber in the bottom of the jar. If it is full of sediment material, the cell will probably have to be replaced, if not now, in the near future.

Plate and separator edges may be inspected while the element is suspended above the jar. A more thorough inspection of separators, plate insulation, grids, and active materials may be indicated. If so, lay the element on its side on a clean non-metallic surface. The plates should be at right angles to the table surface so the element can be fanned slightly to permit the removal of separators if required (Fig. VI-7).

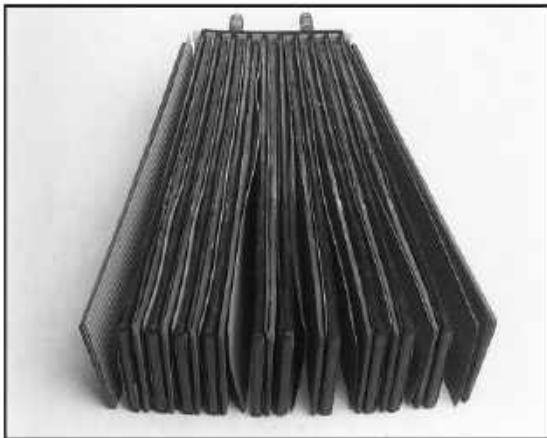

Fig. VI-7

When reinstalling separators, make certain that the flat side of the separator is against the negative plate and the ribbed side is facing the positive. They should be pushed up until they are flush with the bottom of the element and they should project equally on each side of the plates.

Before installing an element in a previously used jar, wash out any sediment which may have accumulated in the bottom of the jar and clean all compound from around the inside of the top edge (if the battery has a compound seal).

Clamp the element, if necessary, when reinstalling it in the jar. Make certain the element is entering the jar properly and that the plates are at right angles to the plate rest support ribs in the bottom. When installing an element with a hard rubber, compound sealed cover attached, use a putty knife to guide the lip of the cover past the top edges of the jar.

### Reassembling the Battery

If the cell being reassembled, has a heat seal cover-to-jar design, and if care was taken cutting the seal when removing the element, the cover and jar can probably be heat sealed again. If not, a new cover and jar will be needed. Be sure to reinstall the cover with the positive post(s) protruding through the cover post holes marked positive (+). If the cell design incorporates floating positive post seals, push them down firmly over the positive posts until they seat flush on top of the cover after sealing the cover to the jar. Some designs have lead inserts or bushings already molded into both the negative and positive cover post holes. In both cases, these floating post seals and/or lead cover bushings are welded or burned to the terminal posts to prevent electrolyte leakage around the posts using a post burning ring (Fig. VI-8). Before using an open flame to weld the posts and cover bushings, you must once again eliminate any gas from the repaired cell and all surrounding cells. (See Gas Purgings in this section.)



Fig. VI-8

Since special techniques must be used when resealing the cover to jar, East Penn recommends that these cover-to-jar seals not be repaired in the field. Instead, such repairs should be made in authorized East Penn service stations only.

If the cell being reassembled has the sealing compound, cover-to-jar seal, an asphalt type compound is applied to seal the cover to the jar. These covers will have lead bushings molded into both the positive and negative posts. Be sure to reinstall the cover with the positive post(s) protruding through the cover post holes marked positive (+). These cover bushings are welded or burned to the terminal posts to prevent electrolyte leakage around the posts, using a post burning ring.

## SECTION VI — BATTERY REPAIR (cont.)

Cells from which elements were pulled, or which had damaged jars or covers replaced, should be given an equalizing charge and acid should be adjusted immediately following repair and before they are returned to service.

When installing repaired cells or new cells back into the battery, use post lifters, attached to the negative posts, and a block and tackle or lifting beam to lower the cell into the tray (Fig. VI-9). Be sure the polarity is correct when you reassemble the battery - cell terminals should be matched positive (+) to negative (-) and negative (-) to positive (+) with connecting cells.



Fig. VI-9

### Using Sealing Compound

If the battery being reassembled, uses a sealing compound poured between cells and the tray, follow these instructions. If the battery does not use a sealing compound, please disregard these instructions.

The special asphaltic sealing compound needed to perform these repairs can be purchased from your authorized East Penn Agent.

**WARNING:** MELTED SEALING COMPOUND IS EXTREMELY HOT - TAKE PROPER SAFETY PRECAUTIONS AND WEAR EYE PROTECTION, GLOVES AND LONG-SLEEVED CLOTHING. WHEN MELTING COMPOUND, DON'T PUNCTURE THE TOP FILM OF UNMELTED COMPOUND BECAUSE PRESSURE MIGHT CAUSE SOME OF THE MELTED COMPOUND BELOW IT TO SQUIRT OUT.

The compound should be about 350°F when poured, if the compound begins to smoke while it is melted, it is probably being overheated.

When the compound is completely melted, pour it into the channel around the new cell or around all cells and tray perimeter if entire battery is being resealed. While the compound is still fairly warm and soft, use a yellow flame to heat it so that it attaches to all cell covers and tray edges, creating a complete seal (Fig. VI-10). Be careful not to burn the plastic jar and cover or tray finish. Now apply another layer of compound and flame it until its surface is smooth and the channel is well sealed.

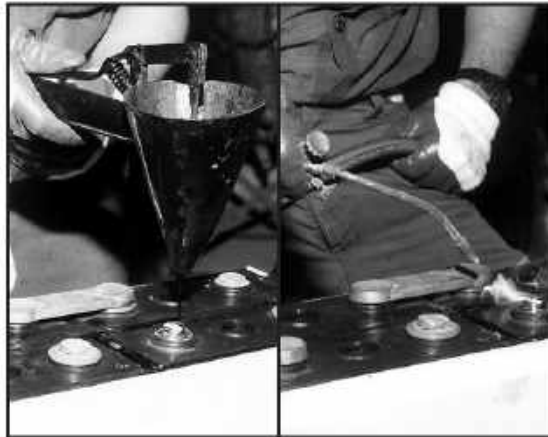

Fig. VI-10

### Attaching Intercell Connectors

Use a wire brush to clean the posts and the connectors that will be reattached to the cells. Have the vent caps in place during wire brushing - do not allow lead particles or pieces of the wire brush to fall into the cells. Clean all lead chips and wire pieces from the battery top before proceeding. Install the connectors and then use a connector button mold and a torch to melt the connectors to the posts (Fig. VI-11). Again, take the necessary precaution to remove trapped explosive gases before using an open flame on top of the battery. (See Gas Purging this section.)



Fig. VI-11

### Replacing Acid and Charging

When replacing electrolyte in a repaired cell, use only sulfuric acid that has the same specific gravity as the acid in the majority of the other cells. Fill the cell to 1/4" below the vent well and then replace the vent cap. Put the battery on an equalizing charge, make another check of the specific gravity and electrolyte level in each cell, and then return the battery to service.

SECTION VII — SAFETY DATA SHEETS



**SAFETY DATA SHEET**  
**LEAD ACID BATTERY WET,**  
**FILLED WITH ACID**

**SECTION 1: PRODUCT AND COMPANY IDENTIFICATION**

**PRODUCT NAME:** Lead Acid Battery Wet, Filled With Acid  
**OTHER PRODUCT NAMES:** Electric Storage Battery, UN2794

**MANUFACTURER:** East Penn Manufacturing Company  
**ADDRESS:** Deka Road  
 Lyon Station, PA 19536 USA

**EMERGENCY TELEPHONE NUMBERS:** US/CN: CHEMTREC 1-800-424-9300  
 Outside US/CN: CHEMTREC 1-703-527-3887

**NON-EMERGENCY HEALTH/SAFETY INFORMATION:** 610-682-6361

**CHEMICAL FAMILY:** This product is a wet lead acid storage battery. May also include gel/absorbed electrolyte lead acid battery types.

**PRODUCT USE:** Industrial/Commercial electrical storage batteries.

**SECTION 2: HAZARDS IDENTIFICATION**

**GHS Classification:**

Health	Environmental	Physical
Acute Toxicity – Category 4 Skin Corrosion – Category 1A Eye Damage – Category 1 Reproductive – Category 1A Carcinogenicity (lead)– Category 1B Carcinogenicity (arsenic)– Category 1A Carcinogenicity(acid mist)–Category1A Specific Target Organ Toxicity (repeated exposure) –Category 2 GHS Label:	Aquatic Chronic – 1 Aquatic Acute – 1	Explosive Chemical, Division 1.3

**Signal Word: DANGER !**



**SAFETY DATA SHEET**  
**LEAD ACID BATTERY WET,**  
**FILLED WITH ACID**

<u>Hazard Statements</u>	<u>Precautionary Statements</u>
<p><b>Health</b>            Harmful if swallowed, inhaled, or in contact with skin.            Causes severe skin burns and eye damage.            Causes serious eye damage.            May damage fertility or the unborn child if ingested or inhaled.            May cause cancer if ingested or inhaled.            Causes damage to central nervous system, blood and kidneys through prolonged or repeated exposure if ingested or inhaled.            May cause harm to breast-fed children.</p> <p><b>Environmental</b>            Very toxic to aquatic life with long lasting effects.</p> <p><b>Physical</b>            May form explosive air/gas mixture during charging.            Extremely flammable gas (hydrogen).            Explosive; fire, blast or projection hazard.            Obtain special instructions before use.            Do not handle until all safety precautions have been read and understood.</p>	<p><b>Prevention</b>            Wash thoroughly after handling.            Do not eat, drink or smoke when using this product.            Wear protective gloves/protective clothing, eye protection/face protection.            Avoid breathing dust/fume/gas/mist/vapors/spray.            Use only outdoors or in a well-ventilated area.            Causes skin irritation, serious eye damage.            Contact with internal components may cause irritation or severe burns.            Avoid contact with internal acid.            Irritating to eyes, respiratory system, and skin.            Avoid contact during pregnancy/while nursing.</p> <p><b>Response</b>            IF SWALLOWED OR CONSUMED: rinse mouth, Do NOT induce vomiting.            Call a poison center/doctor if you feel unwell.            IF ON CLOTHING OR SKIN (or hair): Remove/Take off immediately all contaminated clothing and wash it before reuse. Rinse skin with water/shower.            IF INHALED: Remove person to fresh air and keep comfortable for breathing.            Immediately call a POISON CENTER or doctor/physician.            IF IN EYES: Rinse cautiously with water for several minutes. Remove contact lenses, if present and easy to do. Continue rinsing.            If exposed/concerned, or if you feel unwell seek medical attention/advice.</p> <p><b>Storage and Disposal</b>            Store locked up, in a well-ventilated area. In accordance with local and national regulation.            Avoid release to the environment.            Collect spillage.            Dispose of contents/container in accordance with local/regional/national/international regulations.            Keep away from heat/sparks/open flames/hot surfaces.            No smoking.            Use only outdoors or in well ventilated area            Keep out of reach of children.</p>

**EMERGENCY OVERVIEW:** May form explosive air/gas mixture during charging. Contact with internal components may cause irritation or severe burns. Irritating to eyes, respiratory system, and skin. Prolonged inhalation or ingestion may result in serious damage to health. Pregnant women exposed to internal components may experience reproductive/developmental effects.

**Additional Information**  
 No health effects are expected related to normal use of this product as sold.

**SECTION 3: COMPOSITION/INFORMATION ON INGREDIENTS**

<u>INGREDIENTS (Chemical/Common Names):</u>	<u>CAS No.:</u>	<u>% by Wt:</u>	<u>EC No.:</u>
Lead and Lead Compounds, inorganic	7439-92-1	43-70 (average: 65)	231-100-4
Electrolyte (Sulfuric acid and water)	7664-93-9	20-44 (average: 25)	231-639-5
Antimony	7440-36-0	0-4 (average: <1)	231-146-5

SECTION VII — SAFETY DATA SHEETS (cont.)



**SAFETY DATA SHEET**  
**LEAD ACID BATTERY WET,**  
**FILLED WITH ACID**

Polypropylene

9003-07-0

5-10 (average: 8)

NA

NA – Not applicable/ND – Not determined

Additional Information

These ingredients reflect components of the finished product related to performance of the product as distributed into commerce. Inorganic lead, lead compounds and electrolyte (sulfuric acid) are the primary components. Other metals (i.e. Sn, Cu, As) may be present at concentrations below the applicable reporting threshold.

**SECTION 4: FIRST AID MEASURES**

- EYE CONTACT:** Sulfuric Acid and Lead: Flush eyes immediately with large amounts of water for at least 15 minutes while lifting lids. Seek immediate medical attention if eyes have been exposed directly to acid.
- SKIN CONTACT:** Sulfuric Acid: Flush affected area(s) with large amounts of water using deluge emergency shower, if available, shower for at least 15 minutes. Remove contaminated clothing, including shoes. If symptoms persist, seek medical attention. Wash contaminated clothing before reuse. Discard contaminated shoes.  
Lead: Wash immediately with soap and water.
- INGESTION:** Sulfuric Acid: Give large amounts of water. Do NOT induce vomiting or aspiration into the lungs may occur and can cause permanent injury or death; consult physician.
- INHALATION:** Sulfuric Acid: Remove to fresh air immediately. If not breathing, give artificial respiration. If breathing is difficult, give oxygen. Consult a physician.  
Lead: Remove from exposure, gargle, wash nose and lips; consult physician.

**SECTION 5: FIRE-FIGHTING MEASURES**

**FLASH POINT:** Not Applicable.

**FLAMMABLE LIMITS:** LEL= 4.1% (Hydrogen Gas in air); UEL=74.2%

**EXTINGUISHING MEDIA:** CO<sub>2</sub> ; foam; dry chemical. Do not use carbon dioxide directly on cells. Avoid breathing vapors. Use appropriate media for surrounding fire.

**FIRE-FIGHTING PROCEDURES:** Use positive pressure, self-contained breathing apparatus. Beware of acid splatter during water application and wear acid-resistant clothing, gloves, face and eye protection. If batteries are on charge, shut off power to the charging equipment, but note that strings of series connected batteries may still pose risk of electric shock even when charging equipment is shut down.

**HAZARDOUS COMBUSTION PRODUCTS:** Highly flammable hydrogen gas is generated during charging and operation of batteries. If ignited by burning cigarette, naked flame or spark, may cause battery explosion with dispersion of casing fragments and corrosive liquid electrolyte. Carefully follow manufacturer's instructions for installation and service. Keep away all sources of gas ignition and do not allow metallic articles to simultaneously contact the negative and positive terminals of a battery.

Additional Information

Fire-fighting water runoff and dilution water may be toxic and corrosive and may cause adverse environmental impacts.

**SECTION 6: ACCIDENTAL RELEASE MEASURES**

Stop flow of material, contain/absorb small spills with dry sand, earth, and vermiculite. Do not use combustible materials. If possible, carefully neutralize spilled electrolyte with soda ash, sodium bicarbonate, lime, etc. Wear acid-resistant clothing, boots, gloves, and face shield. Do not allow discharge of un-neutralized acid to sewer. Acid must be managed in accordance with approved local, state, and federal requirements. Consult state environmental agency and/or federal EPA.

Additional Information

Lead acid batteries are recyclable. Contact your East Penn representative for recycling information.

**SECTION 7: HANDLING AND STORAGE**

**Handling:** Unless involved in recycling operations, do not breach the casing or empty the contents of the battery. Handle



**SAFETY DATA SHEET**  
**LEAD ACID BATTERY WET,**  
**FILLED WITH ACID**

carefully and avoid tipping, which may allow electrolyte leakage. There may be increasing risk of electric shock from strings of connected batteries. Keep containers tightly closed when not in use. If battery case is broken, avoid contact with internal components. Keep vent caps on and cover terminals to prevent short circuits. Place cardboard between layers of stacked automotive batteries to avoid damage and short circuits. Keep away from combustible materials, organic chemicals, reducing substances, metals, strong oxidizers and water. Use banding or stretch wrap to secure items for shipping.

**Storage:** Store batteries under roof in cool, dry, well-ventilated areas separated from incompatible materials and from activities that may create flames, spark or heat. Store on smooth, impervious surfaces provided with measures for liquid containment in the event of electrolyte spills. Keep away from metallic objects that could bridge the terminals on a battery and create a dangerous short-circuit.

**Charging:** There is a possible risk of electric shock from charging equipment and from strings of series connected batteries, whether or not being charged. Shut-off power to chargers whenever not in use and before detachment of any circuit connections. Batteries being charged will generate and release flammable hydrogen gas. Charging space should be ventilated. Keep battery vent caps in position. Prohibit smoking and avoid creation of flames and sparks nearby. Wear face and eye protection when near batteries being charged.

**SECTION 8: EXPOSURE CONTROLS/PERSONAL PROTECTION**

Exposure Limits (mg/m <sup>3</sup> )						
Ingredients	OSHA PEL	ACGIH	US NIOSH	Quebec PEV	Ontario OEL	EU OEL
Lead, inorganic	0.05	0.05	0.05	0.05	0.05	0.15 (b)
Antimony	0.5	0.5	0.5	0.5	0.5	0.5 (b,d)
Tin	2	2	2			
Copper	1	1	1	1	1 (a)	0.1 (e)
Arsenic	0.01	0.01	0.01			
Sulfuric Acid	1	0.2	1	1	0.2	0.05 (c)
Polypropylene	N.E.	N.E.	N.E.	N.E.	N.E.	N.E.

(a) As dusts/mists (b) As inhalable aerosol (c) Thoracic fraction (d) Based on OEL's of Austria, Belgium, Denmark, France, Netherlands, Switzerland, & U.K. (e) Based on OEL of Netherlands

**ENGINEERING CONTROLS/SYSTEM DESIGN INFORMATION:**

Store and handle in well-ventilated area. If mechanical ventilation is used, components must be acid-resistant. Handle batteries cautiously, do not tip to avoid spills. Make certain vent caps are on securely. If battery case is damaged, avoid bodily contact with internal components. Wear protective clothing, eye and face protection, when filling, charging, or handling batteries. Do not allow metallic materials to simultaneously contact both the positive and negative terminals of the batteries. Charge batteries in areas with adequate ventilation. General dilution ventilation is acceptable.

**RESPIRATORY PROTECTION (NIOSH/MSHA approved):**

None required under normal conditions. When concentrations of sulfuric acid mist are known to exceed PEL, use NIOSH or MSHA-approved respiratory protection.

**EYE PROTECTION:**

If battery case is damaged, use chemical goggles or face shield.

**SKIN PROTECTION:**

If battery case is damaged, use rubber or plastic acid-resistant gloves with elbow-length gauntlet, acid-resistant apron, clothing and boots.

**OTHER PROTECTION:** In areas where water and sulfuric acid solutions are handled in concentrations greater than 1%, emergency eyewash stations and showers should be provided, with unlimited water supply. Chemically impervious apron and face shield recommended when adding water or electrolyte to batteries.

**Wash Hands after handling.**

SECTION VII — SAFETY DATA SHEETS (cont.)



**SAFETY DATA SHEET**  
**LEAD ACID BATTERY WET,**  
**FILLED WITH ACID**

Additional Information

- Batteries are housed in polypropylene cases which are regulated as total dust or respirable dust only when they are ground up during recycling. The OSHA PEL for dust is 15 mg/m<sup>3</sup> as total dust or 5 mg/m<sup>3</sup> as respirable dust.
- May be required to meet Domestic Requirements for a Specific Destination(s).

**SECTION 9: PHYSICAL AND CHEMICAL PROPERTIES**

<b>APPEARANCE:</b>	Industrial/commercial lead acid battery
<b>ODOR:</b>	Odorless
<b>ODOR THRESHOLD:</b>	Manufactured article; no apparent odor. Electrolyte is a clear liquid with a sharp, penetrating, pungent odor.
<b>PHYSICAL STATE:</b>	Sulfuric Acid: Liquid; Lead: solid
<b>pH:</b>	~1 to 2
<b>BOILING POINT:</b>	203-240° F (as sulfuric acid)
<b>MELTING POINT:</b>	NA
<b>FREEZING POINT:</b>	NA
<b>VAPOR PRESSURE:</b>	10 mmHg
<b>VAPOR DENSITY (AIR = 1):</b>	> 1
<b>SPECIFIC GRAVITY (H<sub>2</sub>O = 1):</b>	1.215–1.350
<b>EVAPORATION RATE (n-BuAc=1):</b>	< 1
<b>SOLUBILITY IN WATER:</b>	100% (as sulfuric acid)
<b>FLASH POINT:</b>	Below room temperature (as hydrogen gas)
<b>AUTO-IGNITION TEMPERATURE:</b>	NA
<b>LOWER EXPLOSIVE LIMIT (LEL):</b>	4% (as hydrogen gas)
<b>UPPER EXPLOSIVE LIMIT (UEL):</b>	74% (as hydrogen gas)
<b>PARTITION COEFFICIENT:</b>	NA
<b>VISCOSITY (poise @ 25° C):</b>	Not Available
<b>DECOMPOSITION TEMPERATURE:</b>	Not Available

**SECTION 10: STABILITY AND REACTIVITY**

<b>STABILITY:</b>	This product is stable under normal conditions at ambient temperature.
<b>INCOMPATIBILITY (MATERIAL TO AVOID):</b>	<u>Electrolyte:</u> Contact with combustibles and organic materials may cause fire and explosion. Also reacts violently with strong reducing agents, metals, sulfur trioxide gas, strong oxidizers, and water. Contact with metals may produce toxic sulfur dioxide fumes and may release flammable hydrogen gas. <u>Lead compounds:</u> Avoid contact with strong acids, bases, halides, halogenates, potassium nitrate, permanganate, peroxides, nascent hydrogen, and reducing agents. <u>Arsenic compounds:</u> strong oxidizers; bromine azide. NOTE: hydrogen gas can react with inorganic arsenic to form the highly toxic gas-arsine <u>Electrolyte:</u> Sulfur trioxide, carbon monoxide, sulfuric acid mist, sulfur dioxide, hydrogen sulfide. <u>Lead compounds:</u> Temperatures above the melting point are likely to produce toxic metal fume, vapor, or dust; contact with strong acid or base or presence of nascent hydrogen may generate highly toxic arsine gas.
<b>HAZARDOUS DECOMPOSITION BY-PRODUCTS:</b>	
<b>HAZARDOUS POLYMERIZATION:</b>	Will not occur
<b>CONDITIONS TO AVOID:</b>	Prolonged overcharge at high current; sources of ignition.

**SECTION 11: TOXICOLOGICAL INFORMATION**

**ACUTE TOXICITY (Test Results Basis and Comments):**  
 Inhalation LD<sub>50</sub>:  
Electrolyte: LC<sub>50</sub> rat 375 mg/m<sup>3</sup> ; LC<sub>50</sub> guinea pig: 510 mg/m<sup>3</sup>



**SAFETY DATA SHEET**  
**LEAD ACID BATTERY WET,**  
**FILLED WITH ACID**

Elemental Lead: Acute Toxicity Point Estimate =4500 ppm V (based on lead bullion)

Elemental Arsenic: No data

Oral LD<sub>50</sub>:

Electrolyte: rat 2140 mg/kg

Elemental Lead: Acute Toxicity Estimate (ATE) = 500mg/kg body weight (based on lead bullion)

Elemental Arsenic: LD<sub>50</sub> mouse: 145 mg/kg

Elemental Antimony: LD<sub>50</sub> rat: 100 mg/kg

**Routes of Entry:** Sulfuric Acid: Harmful by all routes of entry. Lead Compounds: Hazardous exposure can occur only when product is heated, oxidized or otherwise processed or damaged to create dust, vapor or fume. The presence of nascent hydrogen may generate highly toxic arsine gas.

**Inhalation:** Sulfuric Acid: Breathing of sulfuric acid vapors or mists may cause severe respiratory irritation.

Lead Compounds: Inhalation of lead dust or fumes may cause irritation of upper respiratory tract and lungs.

**Ingestion:** Sulfuric Acid: May cause severe irritation of mouth, throat, esophagus and stomach. Lead Compounds: Acute ingestion may cause abdominal pain, nausea, vomiting, diarrhea and severe cramping. This may lead rapidly to systemic toxicity and must be treated by a physician.

**Skin Contact:** Sulfuric Acid: Severe irritation, burns and ulceration. Lead Compounds: Not absorbed through the skin.

Arsenic Compounds: Contact may cause dermatitis and skin hyperpigmentation.

**Eye Contact:** Sulfuric Acid: Severe irritation, burns, cornea damage, and blindness.

Lead Compounds: May cause eye irritation.

**Effects of Overexposure Acute:** Sulfuric Acid: Severe skin irritation, damage to cornea, upper respiratory irritation. Lead Compounds: Symptoms of toxicity include headache, fatigue, abdominal pain, loss of appetite, muscular aches and weakness, sleep disturbances and irritability.

**Effects of Overexposure – Chronic:** Sulfuric Acid: Possible erosion of tooth enamel, inflammation of nose, throat & bronchial tubes. Lead Compounds: Anemia; neuropathy, particularly of the motor nerves, with wrist drop; kidney damage; reproductive changes in males and females. Repeated exposure to lead and lead compounds in the workplace may result in nervous system toxicity. Some toxicologists report abnormal conduction velocities in persons with blood lead levels of 50µg/100 ml or higher. Heavy lead exposure may result in central nervous system damage, encephalopathy and damage to the blood-forming (hematopoietic) tissues.

**Carcinogenicity:** Sulfuric Acid: The International Agency for Research on Cancer (IARC) has classified "strong inorganic acid mist containing sulfuric acid" as a Category I carcinogen, a substance that is carcinogenic to humans. This classification does not apply to liquid forms of sulfuric acid or sulfuric acid solutions contained within a battery. Inorganic acid mist (sulfuric acid mist) is not generated under normal use of this product. Misuse of the product, such as overcharging, may result in the generation of sulfuric acid mist. Lead Compounds: Lead is listed as a 2B carcinogen, likely in animals at extreme doses. Proof of carcinogenicity in humans is lacking at present. Arsenic: Listed by National Toxicology Program (NTP), International Agency for Research on Cancer (IARC), OSHA and NIOSH as a carcinogen only after prolonged exposure at high levels.

**Medical Conditions Generally Aggravated by Exposure:** Overexposure to sulfuric acid mist may cause lung damage and aggravate pulmonary conditions. Contact of sulfuric acid with skin may aggravate diseases such as eczema and contact dermatitis. Lead and its compounds can aggravate some forms of kidney, liver and neurologic diseases.

**Additional Health Data:**

All heavy metals, including the hazardous ingredients in this product, are taken into the body primarily by inhalation and ingestion. Most inhalation problems can be avoided by adequate precautions such as ventilation and respiratory protection covered in Section 8. Follow good personal hygiene to avoid inhalation and ingestion: wash hands, face, neck and arms thoroughly before eating, smoking or leaving the work site. Keep contaminated clothing out of non-contaminated areas, or wear cover clothing when in such areas. Restrict the use and presence of food, tobacco and cosmetics to non-contaminated areas. Work clothes and work equipment used in contaminated areas must remain in designated areas and never taken home or laundered with personal non-contaminated clothing. This product is intended for industrial use only and should be isolated from children and their environment.

The 19<sup>th</sup> Amendment to EC Directive 67/548/EEC classified lead compounds, but not lead in metal form, as possibly toxic to reproduction. Risk phrase 61: May cause harm to the unborn child, applies to lead compounds, especially soluble forms.

SECTION VII — SAFETY DATA SHEETS (cont.)



**SAFETY DATA SHEET**  
**LEAD ACID BATTERY WET,**  
**FILLED WITH ACID**

**SECTION 12: ECOLOGICAL INFORMATION**

**Environmental Fate:** Lead is very persistent in soil and sediments. No data on environmental degradation. Mobility of metallic lead between ecological compartments is slow. Bioaccumulation of lead occurs in aquatic and terrestrial animals and plants but little bioaccumulation occurs through the food chain. Most studies include lead compounds and not elemental lead.

**Environmental Toxicity:**

**Sulfuric acid:** 24-hr LC<sub>50</sub>, fresh water fish (*Brachydanio rerio*): 82 mg/l  
 96-hr LOEC, fresh water fish (*Cyprinus carpio*): 22 mg/l (lowest observable effect concentration)  
**Lead:** 48-hr LC<sub>50</sub> (modeled for aquatic invertebrates): <1mg/L, based on lead bullion  
**Arsenic:** 24-hr LC<sub>50</sub>, freshwater fish (*Carrassius auratus*): >5000g/L

**Additional Information**

- No known effects on stratospheric ozone depletion.
- Volatile organic compounds: 0% (by Volume)
- Water Endangering Class (WGK): NA

**SECTION 13: DISPOSAL CONSIDERATIONS (UNITED STATES)**

**WASTE DISPOSAL METHOD:**

**Spent batteries:** Send to secondary lead smelter for recycling. Contact your East Penn Mfg. representative for more information related to lead acid battery recycling. Spent lead acid batteries are not regulated as hazardous waste when the requirements of 40 CFR Section 266.80 are met. If applicable; EPA hazardous waste number D002 (corrosivity) and D008 (lead). **Electrolyte:** Place neutralized slurry into sealed acid resistant containers and dispose of as hazardous waste, as applicable. Large water diluted spills, after neutralization and testing, should be managed in accordance with approved local, state, and federal requirements. Consult state environmental agency and/or federal EPA. Follow local, State/Provincial, and Federal/National regulations applicable to as-used, end-of-life characteristics to be determined by end-user.

**SECTION 14: TRANSPORT INFORMATION**

DOT rules specified in 49 CFR 173.159 Batteries, wet, regulate the transport of wet spillable batteries. 49 CFR 173.159 (e) specifies that when transported by highway or rail, electric storage batteries containing electrolyte or corrosive battery fluid are not subject to any other requirements of this subchapter, if all of the following are met:

- (1) No other hazardous materials may be transported in the same vehicle;
- (2) The batteries must be loaded or braced so as to prevent damage and short circuits in transit;
- (3) Any other material loaded in the same vehicle must be blocked, braced, or otherwise secured to prevent contact with or damage to the batteries; and
- (4) The transport vehicle may not carry material shipped by any person other than the shipper of the batteries.

If any of these requirements are not met, the batteries must be shipped as fully regulated Class 8 Corrosive hazardous materials.

**GROUND – US-DOT/CAN-TDG/EU-ADR/APEC-ADR:**

Proper Shipping Name	Batteries, Wet, Filled with Acid	ID Number	UN2794
Hazard Class	8	Labels	Corrosive
Packing Group	NA		

**AIRCRAFT – ICAO-IATA:**

Proper Shipping Name	Batteries, Wet, Filled with Acid	ID Number	UN2794
Hazard Class	8	Labels	Corrosive
Packing Group	NA		

Reference IATA packing instructions 870

**VESSEL – IMO-IMDG:**

Proper Shipping Name	Batteries, Wet, Filled with Acid	ID Number	UN2794
Hazard Class	8	Labels	Corrosive
Packing Group	NA		

Reference IMDG packing instructions P801



**SAFETY DATA SHEET**  
**LEAD ACID BATTERY WET,**  
**FILLED WITH ACID**

Additional Information

Transport requires proper packaging and paperwork, including the Nature and Quantity of goods, per applicable origin/destination/customs points as-shipped.

<b>SECTION 15: REGULATORY INFORMATION</b>
---

**INVENTORY STATUS:**

All components are listed on the TSCA; EINECS/ELINCS; and DSL, unless noted otherwise below.

**U.S. FEDERAL REGULATIONS:**

**TSCA Section 8b – Inventory Status:** All chemicals comprising this product are either exempt or listed on the TSCA Inventory.

**TSCA Section 12b – (40 CFR Part 707.60(b))** No notice of export will be required for articles, except PCB articles, unless the Agency so requires in the context of individual section 5.6, or 7 actions.

**TSCA Section 13 –(40 CFR Part 707.20):** No import certification required (EPA 305-B-99-001, June 1999, Introduction to the Chemical Import Requirements of the Toxic Substances Control Act, Section IV.A)

**RCRA:** Spent Lead Acid Batteries are subject to streamlined handling requirements when managed in compliance with 40 CFR section 268.80 or 40 CFR part 273. If applicable; EPA hazardous waste number D002 (corrosivity) and D008 (lead).

**STATE REGULATIONS (US):** \*Proposition 65 Warning Battery posts, terminals and related accessories contain lead and lead compounds, chemicals known to the State of California to cause cancer and reproductive harm. Batteries also contain other chemicals known to State of California to cause cancer. Wash hands after handling.

**EPA SARA Title III:**

**Section 302 EPCRA Extremely Hazardous Substances (EHS):** Sulfuric acid is a listed "Extremely Hazardous Substance" under EPCRA, with a Threshold Planning Quantity (TPQ) of 1,000 lbs. EPCRA Section 302 notification is required if 500 lbs. or more of sulfuric acid is present at one site (40 CFR 370.10). For more information consult 40 CFR Part 355.

**Section 304 CERCLA Hazardous Substances:** Reportable Quantity (RQ) for spilled 100% sulfuric acid under CERCLA (Superfund) and EPCRA (Emergency Planning and Community Right to Know Act) is 1,000 lbs. State and local reportable quantities for spilled sulfuric acid may vary.

**Section 311/312 Hazard Categorization:** EPCRA Section 312 Tier II reporting is required for non-automotive batteries if sulfuric acid is present in quantities of 500 lbs. or more and/or if lead is present in quantities of 10,000 lbs. or more. For more information consult 40 CFR 370.10 and 40 CFR 370.40.

**Section 313 EPCRA Toxic Substances:** 40 CFR Section 372.38(b) states: If toxic chemical is present in an article at a covered facility, a person is not required to consider the quantity of the toxic chemical present in such article when determining whether an applicable threshold has been met under 40 CFR's 372.25,372.27, or 372.28 or determining the amount of release to be reported under 40 CFR 372.30. This exemption applies whether the person received the article from another person or the person produced the article. However, this exemption applies only to the quantity of the toxic chemical present in the article.

The reporting of lead and sulfuric acid (and their releases) in leadacid batteries used in cars, trucks, most cranes, forklifts, locomotive engines, and aircraft for the purposes of EPCRA Section 313 is not required. Lead acid batteries used for these purposes are exempt for Section 313 reporting per the "Motor Vehicle Exemption." See page B-22 of the U.S. EPA Guidance Document for Lead and Lead Compound Reporting under EPCRA Section 313 for additional information of this exemption.

Always check your state/local requirements as they may differ.

**Supplier Notification:** This product contains toxic chemicals that may be reportable under EPCRA Section 313 Toxic Chemical Release Inventory (Form R) requirements. For a manufacturing facility under SIC codes 20 through 39, the following information is provided to enable you to complete the required reports:

<u>Toxic Chemical</u>	<u>CAS Number</u>	<u>Approximate % by Weight</u>
Lead	7439-92-1	65
Electrolyte (Sulfuric Acid/Water Solution)	7664-93-9	25
Antimony	7440-36-0	< 1.0
Arsenic	7440-38-2	<0.1



**SAFETY DATA SHEET**  
**LEAD ACID BATTERY WET,**  
**FILLED WITH ACID**

See 40 CFR Part 370 for more details.

Additional Information

This product may be subject to Restriction of Hazardous Substances (RoHS) regulations in Europe and China, or may be regulated under additional regulations and laws not identified above, such as for uses other than described or as-designed/as-intended by the manufacturer, or for distribution into specific domestic destinations.

---

**SECTION 16: OTHER INFORMATION**

---

**OTHER INFORMATION:**

NFPA Hazard Rating for Sulfuric acid:

Flammability (Red) = 0

Health (Blue) = 3

Reactivity (Yellow) = 2

Sulfuric acid is water-reactive if concentrated.

Distribution into Quebec to follow Canadian Controlled Product Regulations (CPR) 24(1) and 24(2).

Distribution into the EU to follow applicable Directives to the Use, Import/Export of the product as-sold.

**SDS PREPARATION INFORMATION:**

DATE OF ISSUE: 13 May 2015

**DISCLAIMER:**

This Safety Data Sheet is based upon information and sources available at the time of preparation or revision date. Information in the SDS was obtained from sources which we believe are reliable, but are beyond our direct supervision or control. We make no Warranty of Merchantability, Fitness for any particular purpose or any other Warranty, Expressed or Implied, with respect to such information and we assume no liability resulting from its use. For this and other reasons, we do not assume responsibility and expressly disclaim liability for loss, damage or expense arising out of or in any way connected with the handling, storage, use or disposal of the product. It is the obligation of each user of this product to determine the suitability of this product and comply with the requirements of all applicable laws regarding use and disposal of this product. For additional information concerning East Penn Manufacturing Co. products or questions concerning the content of this SDS please contact your East Penn representative.

SECTION VII — SAFETY DATA SHEETS (cont.)



**SAFETY DATA SHEET**  
**VALVE REGULATED LEAD ACID BATTERY,**  
**NON-SPILLABLE**

**SECTION 1: PRODUCT AND COMPANY IDENTIFICATION**

**PRODUCT NAME:** NON-SPILLABLE Battery  
**OTHER PRODUCT NAMES:** Valve Regulated Lead Acid Battery (gel/absorbed electrolyte), Electric Storage Battery  
 Battery Non-Spillable 49 CFR 173.159a

**MANUFACTURER:** East Penn Manufacturing Company  
**ADDRESS:** Deko Road  
 Lyon Station, PA 19536 USA

**EMERGENCY TELEPHONE NUMBERS:** US/CN: CHEMTREC 1-800-424-9300  
 Outside US/CN: CHEMTREC 1-703-527-3887

**NON-EMERGENCY HEALTH/SAFETY INFORMATION:** 610-682-6361

**CHEMICAL FAMILY:** This product is a gel/absorbed electrolyte type lead acid storage battery.

**PRODUCT USE:** Consumer/Industrial/Commercial electrical storage batteries.

**SECTION 2: HAZARDS IDENTIFICATION**

**GHS Classification:**

Health	Environmental	Physical
Acute Toxicity – Category 4 Skin Corrosion – Category 1A Eye Damage – Category 1 Reproductive – Category 1A Carcinogenicity (lead)– Category 1B Carcinogenicity (arsenic)– Category 1A Carcinogenicity(acid mist)–Category1A Specific Target Organ Toxicity (repeated exposure) –Category 2 GHS Label:	Aquatic Chronic – 1 Aquatic Acute – 1	Explosive Chemical, Division 1.3

**Signal Word: DANGER !**



**SAFETY DATA SHEET**  
**VALVE REGULATED LEAD ACID BATTERY,**  
**NON-SPILLABLE**

<u>Hazard Statements</u>	<u>Precautionary Statements</u>
<p><b>Health</b>  Harmful if swallowed, inhaled, or in contact with skin.  Causes severe skin burns and eye damage.  Causes serious eye damage.  May damage fertility or the unborn child if ingested or inhaled.  May cause cancer if ingested or inhaled.  Causes damage to central nervous system, blood and kidneys through prolonged or repeated exposure if ingested or inhaled.  May cause harm to breast-fed children.</p> <p><b>Environmental</b>  Very toxic to aquatic life with long lasting effects.</p> <p><b>Physical</b>  May form explosive air/gas mixture during charging.  Extremely flammable gas (hydrogen).  Explosive; fire, blast or projection hazard.  Obtain special instructions before use.  Do not handle until all safety precautions have been read and understood.</p>	<p><b>Prevention</b>  Wash thoroughly after handling.  Do not eat, drink or smoke when using this product.  Wear protective gloves/protective clothing, eye protection/face protection.  Avoid breathing dust/fume/gas/mist/vapors/spray.  Use only outdoors or in a well-ventilated area.  Causes skin irritation, serious eye damage.  Contact with internal components may cause irritation or severe burns.  Avoid contact with internal acid/gel.  Irritating to eyes, respiratory system, and skin.  Avoid contact during pregnancy/while nursing.</p> <p><b>Response</b>  IF SWALLOWED OR CONSUMED: rinse mouth, Do NOT induce vomiting.  Call a poison center/doctor if you feel unwell.  IF ON CLOTHING OR SKIN (or hair): Remove/Take off immediately all contaminated clothing and wash it before reuse. Rinse skin with water/shower.  IF INHALED: Remove person to fresh air and keep comfortable for breathing.  Immediately call a POISON CENTER or doctor/physician.  IF IN EYES: Rinse cautiously with water for several minutes. Remove contact lenses, if present and easy to do. Continue rinsing.  If exposed/concerned, or if you feel unwell seek medical attention/advice.</p> <p><b>Storage and Disposal</b>  Store locked up, in a well-ventilated area. In accordance with local and national regulation.  Avoid release to the environment.  Collect spillage.  Dispose of contents/container in accordance with local/regional/national/international regulations.  Keep away from heat/sparks/open flames/hot surfaces.  No smoking.  Use only outdoors or in well ventilated area  Keep out of reach of children.</p>

**EMERGENCY OVERVIEW:** May form explosive air/gas mixture during charging. Contact with internal components may cause irritation or severe burns. Irritating to eyes, respiratory system, and skin. Prolonged inhalation or ingestion may result in serious damage to health. Pregnant women exposed to internal components may experience reproductive/developmental effects.

Additional Information  
No health effects are expected related to normal use of this product as sold.

**SECTION 3: COMPOSITION/INFORMATION ON INGREDIENTS**

<u>INGREDIENTS (Chemical/Common Names):</u>	<u>CAS No.:</u>	<u>% by Wt:</u>	<u>EC No.:</u>
Lead and Lead Compounds, inorganic	7439-92-1	60-75 (average: 67)	231-100-4
Electrolyte (Sulfuric acid and water)	7664-93-9	5-15 (average:10)	231-639-5
Antimony	7440-36-0	0-0.1 (average:<0.1)	231-146-5

## SECTION VII — SAFETY DATA SHEETS (cont.)



### SAFETY DATA SHEET VALVE REGULATED LEAD ACID BATTERY, NON-SPILLABLE

Polypropylene

9003-07-0

2-10 (average: 4)

NA

NA – Not applicable/ND – Not determined

#### Additional Information

These ingredients reflect components of the finished product related to performance of the product as distributed into commerce. Inorganic lead, lead compounds and electrolyte (sulfuric acid) are the primary components. Other metals (ie. Sn, Cu, As) may be present at concentrations below the applicable reporting threshold.

#### SECTION 4: FIRST AID MEASURES

- EYE CONTACT:** Sulfuric Acid and Lead: Flush eyes immediately with large amounts of water for at least 15 minutes while lifting lids. Seek immediate medical attention if eyes have been exposed directly to acid.
- SKIN CONTACT:** Sulfuric Acid: Flush affected area(s) with large amounts of water using deluge emergency shower, if available, shower for at least 15 minutes. Remove contaminated clothing, including shoes. If symptoms persist, seek medical attention. Wash contaminated clothing before reuse. Discard contaminated shoes.  
Lead: Wash immediately with soap and water.
- INGESTION:** Sulfuric Acid: Give large amounts of water. Do NOT induce vomiting or aspiration into the lungs may occur and can cause permanent injury or death; consult physician.
- INHALATION:** Sulfuric Acid: Remove to fresh air immediately. If not breathing, give artificial respiration. If breathing is difficult, give oxygen. Consult a physician.  
Lead: Remove from exposure, gargle, wash nose and lips; consult physician.

#### SECTION 5: FIRE-FIGHTING MEASURES

**FLASH POINT:** Not Applicable.

**FLAMMABLE LIMITS:** LEL= 4.1% (Hydrogen Gas in air); UEL=74.2%

**EXTINGUISHING MEDIA:** CO<sub>2</sub>; foam; dry chemical. Do not use carbon dioxide directly on cells. Avoid breathing vapors. Use appropriate media for surrounding fire.

**FIRE-FIGHTING PROCEDURES:** Use positive pressure, self-contained breathing apparatus. Beware of acid splatter during water application and wear acid-resistant clothing, gloves, face and eye protection. If batteries are on charge, shut off power to the charging equipment, but note that strings of series connected batteries may still pose risk of electric shock even when charging equipment is shut down.

**HAZARDOUS COMBUSTION PRODUCTS:** Highly flammable hydrogen gas is generated during charging and operation of batteries. If ignited by burning cigarette, naked flame or spark, may cause battery explosion with dispersion of casing fragments and corrosive liquid electrolyte. Carefully follow manufacturer's instructions for installation and service. Keep away all sources of gas ignition and do not allow metallic articles to simultaneously contact the negative and positive terminals of a battery.

#### Additional Information

Fire-fighting water runoff and dilution water may be toxic and corrosive and may cause adverse environmental impacts.

#### SECTION 6: ACCIDENTAL RELEASE MEASURES

Content is corrosive. In the event of a rupture, spill or release stop flow of material, contain/absorb small spills with dry sand, earth, and vermiculite. Do not use combustible materials. If possible, carefully neutralize spilled electrolyte with soda ash, sodium bicarbonate, lime, etc. Wear acid-resistant clothing, boots, gloves, and face shield. Do not allow discharge of un-neutralized acid to sewer. Acid must be managed in accordance with approved local, state, and federal requirements. Consult state environmental agency and/or federal EPA.

#### Additional Information

Lead acid batteries are recyclable. Contact your East Penn representative for recycling information.

#### SECTION 7: HANDLING AND STORAGE



**SAFETY DATA SHEET**  
**VALVE REGULATED LEAD ACID BATTERY,**  
**NON-SPILLABLE**

**Handling:** Unless involved in recycling operations, do not breach the casing or empty the contents of the battery. There may be increasing risk of electric shock from strings of connected batteries. Keep containers tightly closed when not in use. If battery case is broken, avoid contact with internal components. Keep vent caps on and cover terminals to prevent short circuits. Place cardboard between layers of stacked automotive batteries to avoid damage and short circuits. Keep away from combustible materials, organic chemicals, reducing substances, metals, strong oxidizers and water. Use banding or stretch wrap to secure items for shipping.

**Storage:** Store batteries under roof in cool, dry, well-ventilated areas separated from incompatible materials and from activities that may create flames, spark or heat. Store on smooth, impervious surfaces provided with measures for liquid containment in the rupture, spill or release of electrolyte. Keep away from metallic objects that could bridge the terminals on a battery and create a dangerous short-circuit.

**Charging:** There is a possible risk of electric shock from charging equipment and from strings of series connected batteries, whether or not being charged. Shut-off power to chargers whenever not in use and before detachment of any circuit connections. Batteries being charged will generate and release flammable hydrogen gas. Charging space should be ventilated. Keep battery vent caps in position. Prohibit smoking and avoid creation of flames and sparks nearby. Wear face and eye protection when near batteries being charged.

<b>SECTION 8: EXPOSURE CONTROLS/PERSONAL PROTECTION</b>
---

**Exposure Limits (mg/m<sup>3</sup>)**

Ingredients	OSHA PEL	ACGIH	US NIOSH	Quebec PEV	Ontario OEL	EU OEL
Lead, inorganic	0.05	0.05	0.05	0.05	0.05	0.15 (b)
Antimony	0.5	0.5	0.5	0.5	0.5	0.5 (b,d)
Tin	2	2	2			
Copper	1	1	1	1	1 (a)	0.1 (e)
Arsenic	0.01	0.01	0.01			
Sulfuric Acid	1	0.2	1	1	0.2	0.05 (c)
Polypropylene	N.E.	N.E.	N.E.	N.E.	N.E.	N.E.

(a) As dusts/mists (b) As inhalable aerosol (c) Thoracic fraction (d) Based on OEL's of Austria, Belgium, Denmark, France, Netherlands, Switzerland, & U.K. (e) Based on OEL of Netherlands

**ENGINEERING CONTROLS/SYSTEM DESIGN INFORMATION:**

Store and handle in well-ventilated area. If mechanical ventilation is used, components must be acid-resistant. Handle batteries cautiously to avoid rupture, spill or release. Make certain vent caps are on securely. If battery case is damaged, avoid bodily contact with internal components. Wear protective clothing, eye and face protection, charging or handling batteries. Do not allow metallic materials to simultaneously contact both the positive and negative terminals of the batteries. Charge batteries in areas with adequate ventilation. General dilution ventilation is acceptable.

**RESPIRATORY PROTECTION (NIOSH/MSHA approved):**

None required under normal conditions. When concentrations of sulfuric acid mist are known to exceed PEL, use NIOSH or MSHA-approved respiratory protection.

**EYE PROTECTION:**

If battery case is damaged, use chemical goggles or face shield.

**SKIN PROTECTION:**

If battery case is damaged, use rubber or plastic acid-resistant gloves with elbow-length gauntlet, acid-resistant apron, clothing and boots.

**OTHER PROTECTION:** In areas where water and sulfuric acid solutions are handled in concentrations greater than 1%, emergency eyewash stations and showers should be provided, with unlimited water supply.

**Wash Hands after handling.**



**SAFETY DATA SHEET**  
**VALVE REGULATED LEAD ACID BATTERY,**  
**NON-SPILLABLE**

Additional Information

- Batteries are housed in polypropylene cases which are regulated as total dust or respirable dust only when they are ground up during recycling. The OSHA PEL for dust is 15 mg/m<sup>3</sup> as total dust or 5 mg/m<sup>3</sup> as respirable dust.
- May be required to meet Domestic Requirements for a Specific Destination(s).

<b>SECTION 9: PHYSICAL AND CHEMICAL PROPERTIES</b>
--

<b>APPEARANCE:</b>	Industrial/commercial lead acid battery
<b>ODOR:</b>	Odorless
<b>ODOR THRESHOLD:</b>	Manufactured article; no apparent odor. Electrolyte is a gel with a sharp, penetrating, pungent odor.
<b>PHYSICAL STATE:</b>	Sulfuric Acid: Liquid/Gel; Lead: solid
<b>pH:</b>	~1 to 2
<b>BOILING POINT:</b>	203-240° F (as sulfuric acid)
<b>MELTING POINT:</b>	NA
<b>FREEZING POINT:</b>	NA
<b>VAPOR PRESSURE:</b>	10 mmHg
<b>VAPOR DENSITY (AIR = 1):</b>	> 1
<b>SPECIFIC GRAVITY (H<sub>2</sub>O = 1):</b>	1.27-1.33
<b>EVAPORATION RATE (n-BuAc=1):</b>	< 1
<b>SOLUBILITY IN WATER:</b>	100% (as sulfuric acid)
<b>FLASH POINT:</b>	Below room temperature (as hydrogen gas)
<b>AUTO-IGNITION TEMPERATURE:</b>	NA
<b>LOWER EXPLOSIVE LIMIT (LEL):</b>	4% (as hydrogen gas)
<b>UPPER EXPLOSIVE LIMIT (UEL):</b>	74% (as hydrogen gas)
<b>PARTITION COEFFICIENT:</b>	NA
<b>VISCOSITY (poise @ 25° C):</b>	Not Available
<b>DECOMPOSITION TEMPERATURE:</b>	Not Available

<b>SECTION 10: STABILITY AND REACTIVITY</b>
---

<b>STABILITY:</b>	This product is stable under normal conditions at ambient temperature.
<b>INCOMPATIBILITY (MATERIAL TO AVOID):</b>	<u>Electrolyte:</u> Contact with combustibles and organic materials may cause fire and explosion. Also reacts violently with strong reducing agents, metals, sulfur trioxide gas, strong oxidizers, and water. Contact with metals may produce toxic sulfur dioxide fumes and may release flammable hydrogen gas. <u>Lead compounds:</u> Avoid contact with strong acids, bases, halides, halogenates, potassium nitrate, permanganate, peroxides, nascent hydrogen, and reducing agents. <u>Arsenic compounds:</u> strong oxidizers; bromine azide. NOTE: hydrogen gas can react with inorganic arsenic to form the highly toxic gas-arsine
<b>HAZARDOUS DECOMPOSITION BY-PRODUCTS:</b>	<u>Electrolyte:</u> Sulfur trioxide, carbon monoxide, sulfuric acid mist, sulfur dioxide, hydrogen sulfide. <u>Lead compounds:</u> Temperatures above the melting point are likely to produce toxic metal fume, vapor, or dust; contact with strong acid or base or presence of nascent hydrogen may generate highly toxic arsine gas.
<b>HAZARDOUS POLYMERIZATION:</b>	Will not occur
<b>CONDITIONS TO AVOID:</b>	Prolonged overcharge at high current; sources of ignition.

<b>SECTION 11: TOXICOLOGICAL INFORMATION</b>
--

**ACUTE TOXICITY (Test Results Basis and Comments):**  
 Inhalation LD<sub>50</sub>:  
Electrolyte: LC<sub>50</sub> rat 375 mg/m<sup>3</sup>; LC<sub>50</sub> guinea pig: 510 mg/m<sup>3</sup>



**SAFETY DATA SHEET**  
**VALVE REGULATED LEAD ACID BATTERY,**  
**NON-SPILLABLE**

Elemental Lead: Acute Toxicity Point Estimate = 4500 ppm V (based on lead bullion)

Elemental Arsenic: No data

Oral LD<sub>50</sub>:

Electrolyte: rat 2140 mg/kg

Elemental Lead: Acute Toxicity Estimate (ATE) = 500mg/kg body weight (based on lead bullion)

Elemental Arsenic: LD<sub>50</sub> mouse: 145 mg/kg

Elemental Antimony: LD<sub>50</sub> rat: 100 mg/kg

**Routes of Entry:** Sulfuric Acid: Harmful by all routes of entry. Lead Compounds: Hazardous exposure can occur only when product is heated, oxidized or otherwise processed or damaged to create dust, vapor or fume. The presence of nascent hydrogen may generate highly toxic arsine gas.

**Inhalation:** Sulfuric Acid: Breathing of sulfuric acid vapors or mists may cause severe respiratory irritation.

Lead Compounds: Inhalation of lead dust or fumes may cause irritation of upper respiratory tract and lungs.

**Ingestion:** Sulfuric Acid: May cause severe irritation of mouth, throat, esophagus and stomach. Lead Compounds: Acute ingestion may cause abdominal pain, nausea, vomiting, diarrhea and severe cramping. This may lead rapidly to systemic toxicity and must be treated by a physician.

**Skin Contact:** Sulfuric Acid: Severe irritation, burns and ulceration. Lead Compounds: Not absorbed through the skin.

Arsenic Compounds: Contact may cause dermatitis and skin hyperpigmentation.

**Eye Contact:** Sulfuric Acid: Severe irritation, burns, cornea damage, and blindness.

Lead Compounds: May cause eye irritation.

**Effects of Overexposure Acute:** Sulfuric Acid: Severe skin irritation, damage to cornea, upper respiratory irritation. Lead Compounds: Symptoms of toxicity include headache, fatigue, abdominal pain, loss of appetite, muscular aches and weakness, sleep disturbances and irritability.

**Effects of Overexposure – Chronic:** Sulfuric Acid: Possible erosion of tooth enamel, inflammation of nose, throat & bronchial tubes. Lead Compounds: Anemia; neuropathy, particularly of the motor nerves, with wrist drop; kidney damage; reproductive changes in males and females. Repeated exposure to lead and lead compounds in the workplace may result in nervous system toxicity. Some toxicologists report abnormal conduction velocities in persons with blood lead levels of 50µg/100 ml or higher. Heavy lead exposure may result in central nervous system damage, encephalopathy and damage to the blood-forming (hematopoietic) tissues.

**Carcinogenicity:** Sulfuric Acid: The International Agency for Research on Cancer (IARC) has classified "strong inorganic acid mist containing sulfuric acid" as a Category I carcinogen, a substance that is carcinogenic to humans. This classification does not apply to liquid forms of sulfuric acid or sulfuric acid solutions contained within a battery. Inorganic acid mist (sulfuric acid mist) is not generated under normal use of this product. Misuse of the product, such as overcharging, may result in the generation of sulfuric acid mist. Lead Compounds: Lead is listed as a 2B carcinogen, likely in animals at extreme doses. Proof of carcinogenicity in humans is lacking at present. Arsenic: Listed by National Toxicology Program (NTP), International Agency for Research on Cancer (IARC), OSHA and NIOSH as a carcinogen only after prolonged exposure at high levels.

**Medical Conditions Generally Aggravated by Exposure:** Overexposure to sulfuric acid mist may cause lung damage and aggravate pulmonary conditions. Contact of sulfuric acid with skin may aggravate diseases such as eczema and contact dermatitis. Lead and its compounds can aggravate some forms of kidney, liver and neurologic diseases.

**Additional Health Data:**

All heavy metals, including the hazardous ingredients in this product, are taken into the body primarily by inhalation and ingestion. Most inhalation problems can be avoided by adequate precautions such as ventilation and respiratory protection covered in Section 8. Follow good personal hygiene to avoid inhalation and ingestion: wash hands, face, neck and arms thoroughly before eating, smoking or leaving the work site. Keep contaminated clothing out of non-contaminated areas, or wear cover clothing when in such areas. Restrict the use and presence of food, tobacco and cosmetics to non-contaminated areas. Work clothes and work equipment used in contaminated areas must remain in designated areas and never taken home or laundered with personal non-contaminated clothing. This product is intended for industrial use only and should be isolated from children and their environment.

The 19<sup>th</sup> Amendment to EC Directive 67/548/EEC classified lead compounds, but not lead in metal form, as possibly toxic to reproduction. Risk phrase 61: May cause harm to the unborn child, applies to lead compounds, especially soluble forms.



**SAFETY DATA SHEET**  
**VALVE REGULATED LEAD ACID BATTERY,**  
**NON-SPILLABLE**

**SECTION 12: ECOLOGICAL INFORMATION**

**Environmental Fate:** Lead is very persistent in soil and sediments. No data on environmental degradation. Mobility of metallic lead between ecological compartments is slow. Bioaccumulation of lead occurs in aquatic and terrestrial animals and plants but little bioaccumulation occurs through the food chain. Most studies include lead compounds and not elemental lead.

**Environmental Toxicity:**

**Sulfuric acid:** 24-hr LC<sub>50</sub>, fresh water fish (*Brachydanio rerio*): 82 mg/l  
 96-hr LOEC, fresh water fish (*Cyprinus carpio*): 22 mg/l (lowest observable effect concentration)  
**Lead:** 48-hr LC<sub>50</sub> (modeled for aquatic invertebrates): <1mg/L, based on lead bullion  
**Arsenic:** 24-hr LC<sub>50</sub>, freshwater fish (*Carrassius auratus*)>5000g/L

**Additional Information**

- No known effects on stratospheric ozone depletion.
- Volatile organic compounds: 0% (by Volume)
- Water Endangering Class (WGK): NA

**SECTION 13: DISPOSAL CONSIDERATIONS (UNITED STATES)**

**WASTE DISPOSAL METHOD:**

**Spent batteries:** Send to secondary lead smelter for recycling. Contact your East Penn Mfg. representative for more information related to lead acid battery recycling. Spent lead acid batteries are not regulated as hazardous waste when the requirements of 40 CFR Section 266.80 are met. If applicable; EPA hazardous waste number D002 (corrosivity) and D008 (lead). **Electrolyte:** Place neutralized slurry into sealed acid resistant containers and dispose of as hazardous waste, as applicable. Large water diluted spills, after neutralization and testing, should be managed in accordance with approved local, state, and federal requirements. Consult state environmental agency and/or federal EPA. Follow local, State/Provincial, and Federal/National regulations applicable to as-used, end-of-life characteristics to be determined by end-user.

**SECTION 14: TRANSPORT INFORMATION**

Not regulated pursuant to 49 CFR 173.159a of the DOT Hazardous Materials Regulation provided that each package is marked "NON-SPILLABLE" or "NON-SPILLABLE BATTERY".

For Air shipments reference IATA Dangerous Goods Regulations Special Provision A-67.

For ocean shipments reference IMDG Special Provision #238.

Note: Batteries which have met the test requirements for "non-spillable batteries" in shipment must be protected against short circuit and securely packaged.

Label: NON-SPILLABLE

**Additional Information**

Transport requires proper packaging and paperwork, including the Nature and Quantity of goods, per applicable origin/destination/customs points as-shipped.

**SECTION 15: REGULATORY INFORMATION**

**INVENTORY STATUS:**

All components are listed on the TSCA; EINECS/ELINCS; and DSL, unless noted otherwise below.

**U.S. FEDERAL REGULATIONS:**

**TSCA Section 8b – Inventory Status:** All chemicals comprising this product are either exempt or listed on the TSCA Inventory.

## SECTION VII — SAFETY DATA SHEETS (cont.)



### SAFETY DATA SHEET VALVE REGULATED LEAD ACID BATTERY, NON-SPILLABLE

**TSCA Section 12b** – (40 CFR Part 707.60(b)) No notice of export will be required for articles, except PCB articles, unless the Agency so requires in the context of individual section 5, 6, or 7 actions.

**TSCA Section 13** –(40 CFR Part 707.20): No import certification required (EPA 305-B-99-001, June 1999, Introduction to the Chemical Import Requirements of the Toxic Substances Control Act, Section IV.A)

**RCRA:** Spent Lead Acid Batteries are subject to streamlined handling requirements when managed in compliance with 40 CFR section 266.80 or 40 CFR part 273. If applicable; EPA hazardous waste number D002 (corrosivity) and D008 (lead).

**STATE REGULATIONS (US):** \*Proposition 65 Warning Battery posts, terminals and related accessories contain lead and lead compounds, chemicals known to the State of California to cause cancer and reproductive harm. Batteries also contain other chemicals known to State of California to cause cancer. Wash hands after handling.

#### **EPA SARA Title III:**

**Section 302 EPCRA Extremely Hazardous Substances (EHS):** Sulfuric acid is a listed "Extremely Hazardous Substance" under EPCRA, with a Threshold Planning Quantity (TPQ) of 1,000 lbs. EPCRA Section 302 notification is required if 500 lbs. or more of sulfuric acid is present at one site (40 CFR 370.10). For more information consult 40 CFR Part 355.

**Section 304 CERCLA Hazardous Substances:** Reportable Quantity (RQ) for spilled 100% sulfuric acid under CERCLA (Superfund) and EPCRA (Emergency Planning and Community Right to Know Act) is 1,000 lbs. State and local reportable quantities for spilled sulfuric acid may vary.

**Section 311/312 Hazard Categorization:** EPCRA Section 312 Tier II reporting is required for non-automotive batteries if sulfuric acid is present in quantities of 500 lbs. or more and/or if lead is present in quantities of 10,000 lbs. or more. For more information consult 40 CFR 370.10 and 40 CFR 370.40.

**Section 313 EPCRA Toxic Substances:** 40 CFR Section 372.38(b) states: If toxic chemical is present in an article at a covered facility, a person is not required to consider the quantity of the toxic chemical present in such article when determining whether an applicable threshold has been met under 40 CFR's 372.25, 372.27, or 372.28 or determining the amount of release to be reported under 40 CFR 372.30. This exemption applies whether the person received the article from another person or the person produced the article. However, this exemption applies only to the quantity of the toxic chemical present in the article.

The reporting of lead and sulfuric acid (and their releases) in lead acid batteries used in cars, trucks, most cranes, forklifts, locomotive engines, and aircraft for the purposes of EPCRA Section 313 is not required. Lead acid batteries used for these purposes are exempt for Section 313 reporting per the "Motor Vehicle Exemption." See page B-22 of the [U.S. EPA Guidance Document for Lead and Lead Compound Reporting under EPCRA Section 313](#) for additional information of this exemption.

Always check your state/local requirements as they may differ.

**Supplier Notification:** This product contains toxic chemicals that may be reportable under EPCRA Section 313 Toxic Chemical Release Inventory (Form R) requirements. For a manufacturing facility under SIC codes 20 through 39, the following information is provided to enable you to complete the required reports:

<u>Toxic Chemical</u>	<u>CAS Number</u>	<u>Approximate % by Weight</u>
Lead	7439-92-1	67
Electrolyte (Sulfuric Acid/Water Solution)	7664-93-9	10
Antimony	7440-36-0	< 1.0
Arsenic	7440-38-2	<0.1

See 40 CFR Part 370 for more details.

#### Additional Information

This product may be subject to Restriction of Hazardous Substances (RoHS) regulations in Europe and China, or may be regulated under additional regulations and laws not identified above, such as for uses other than described or as-designed/as-intended by the manufacturer, or for distribution into specific domestic destinations.

#### **SECTION 16: OTHER INFORMATION**

##### **OTHER INFORMATION:**

NFPA Hazard Rating for Sulfuric acid:



**SAFETY DATA SHEET**  
**VALVE REGULATED LEAD ACID BATTERY,**  
**NON-SPILLABLE**

Flammability (Red) = 0  
Health (Blue) = 3  
Reactivity (Yellow) = 2  
Sulfuric acid is water-reactive if concentrated.

Distribution into Quebec to follow Canadian Controlled Product Regulations (CPR) 24(1) and 24(2).  
Distribution into the EU to follow applicable Directives to the Use, Import/Export of the product as-sold.

**SDS PREPARATION INFORMATION:**

DATE OF ISSUE: 13 May 2015

**DISCLAIMER:**

This Safety Data Sheet is based upon information and sources available at the time of preparation or revision date. Information in the SDS was obtained from sources which we believe are reliable, but are beyond our direct supervision or control. We make no Warranty of Merchantability, Fitness for any particular purpose or any other Warranty, Expressed or Implied, with respect to such information and we assume no liability resulting from its use. For this and other reasons, we do not assume responsibility and expressly disclaim liability for loss, damage or expense arising out of or in any way connected with the handling, storage, use or disposal of the product. It is the obligation of each user of this product to determine the suitability of this product and comply with the requirements of all applicable laws regarding use and disposal of this product. For additional information concerning East Penn Manufacturing Co. products or questions concerning the content of this SDS please contact your East Penn representative.

## GLOSSARY

**Acid** In the lead acid storage battery industry, "acid" implies "sulfuric acid", and is used to describe the electrolyte or liquid in the cell.

**Active Materials** The materials in a battery which react chemically to produce electrical energy. In a lead-acid battery the active materials are lead peroxide (positive) and sponge lead (negative).

**Activation** Process for making a dry charged cell functional by introducing electrolyte.

**Air Oxidized** A charged negative plate that has been removed from the electrolyte and permitted to discharge in an air atmosphere with the evolution of heat. Plates so treated must be recharged before they are capable of producing any useful electrical energy.

**Alloy** A combination of two or more metals, as a mixture, solution or compound. See "ANTIMONIAL LEAD ALLOY", "CALCIUM LEAD ALLOY".

**Ambient Temperature** The temperature of the surrounding cooling medium, such as gas or liquid, which comes into contact with the heated parts of the apparatus, usually refers to room or air temp.

**Alternating Current** An electric, pulsating current, in which the direction of flow is rapidly changed, so that a terminal becomes in rapid succession positive then negative.

**Ammeter** An ammeter is an instrument for measuring electrical current. See also "AMPERE-HOUR METER".

**Ampacity** Current carrying capacity in amperes.

**Ampere** The practical unit of electric current that is equivalent to the steady state current produced by one volt applied across a resistance of one ohm. It is one tenth of an abampere.

**Ampere-Hour** A measure of the volume of electricity, being one ampere for one hour, or 3600 coulombs. It is used to express battery capacity, and is registered by an ampere hour meter, or is obtained by multiplying the current in amperes by the length of time that the current is maintained.

**Ampere-Hour Capacity** The number of ampere-hours which can be delivered under specified conditions as to temperature, rate of discharge, and final voltage.

**Ampere-Hour Efficiency** The electrochemical efficiency expressed as the ratio of the ampere-hours output to the ampere-hours input required for the recharge.

**Ampere-Hour Meter** An instrument that registers the quantity of electricity in ampere-hours.

**Assembly** 1. The process of combining the various parts of cells and batteries into the finished product. 2. Any particular arrangement of cells, connectors, and terminals to form a battery suited for a desired application.

**Battery (Storage)** A storage battery is a connected group of two or more storage cells (common usage permits this term to be applied to a single cell used independently). Batteries are sometimes referred to as "Accumulators" since electric energy is accumulated by chemical reaction.

**Bayonet Vent** A term originally applied to a design of quarter turn vent plug the lower portion of which resembles a bayonet, both in appearance and locking arrangement.

**Boost Cells** Cells with higher capacity than the tests cells which are used to help maintain constant discharge current in a manual discharge test.

**Boost Charge** A partial charge given to a storage battery usually at a high rate for a short period. It is employed in motive power service when the capacity of a battery is not sufficient for a full day's work.

**Boot** Plastic piece used at foot of plate, especially a wrapped plate, for retention and insulation.

**Bridge** The ribs or elements supporting structure, molded, or cut to fit into the bottom of a ribless jar or container in order to provide sediment space under the element thereby preventing short circuits.

**Burning** The welding together of two or more lead parts such as plates, straps, connector; by means of heat and in some cases, additional metal supplied by a stick called a burning strip.

**Burning Center** The center-to-center distance between adjacent plates of the same polarity.

**Burning Stick** A lead stick of convenient size used as a supply of joining metal in lead burning.

**Button** The finished "button shaped" area produced on the top surface of a connector or terminal by the post burning operation.

**Cadmium (Cd)** A metallic element highly resistant to corrosion, used as a protective plating on certain steel parts and fittings.

**Cadmium Electrode** A third electrode for separate measurements of the electrode potential of positive and negative plate groups.

**Calcium Lead Alloy** A lead base alloy that in certain applications can be used for battery parts in place of antimonial lead alloys. Most common use is in stationary cells.

**Capacity**  
See "AMPERE HOUR CAPACITY".

**Capacity Test** A test wherein the battery is discharged at constant current at room temperature to a cutoff voltage of usually 1.70 volts/cell.

**Carbon Burning Outfit** A metallic rod and insulated handle, mounting a pointed carbon rod; used for lead burning on service locations where the usual gas flame equipment is not available.

**Carboy** A large cylindrical container or bottle of plastic or glass used to ship acid.

**Cast** To form a molten substance into a definite shape by pouring or forcing the liquid material into a mold and allowing it to solidify (freeze).

**Casting** A metallic item, such as one or more grids, straps or connectors; produced by pouring or forcing molten metal into a mold and allowing it to solidify.

**Cell (Storage)** A storage (secondary) cell is an electrolytic cell for the generation of electric energy in which the cell after being discharged may be restored to a charged condition by an electric current flowing in a direction opposite to the flow of current when the cell discharges.

**Charged** The condition of a storage cell when at its maximum ability to deliver current. The positive plate contains a maximum of lead peroxide and a minimum of sulfate, while the negative plates contain a maximum of sponge lead and a minimum of sulfate, and the electrolyte will be at maximum specific gravity.

**Charged and Dry** A battery assembled with dry, charged plates, and no electrolyte.

**Charged and Wet** A fully charged battery containing electrolyte and ready to deliver current.

**Charging** The process of converting electrical energy to stored chemical energy. In the lead-acid system, charging converts Lead Sulfate ( $PbSO_4$ ) in the plates to Lead Peroxide ( $PbO_2$ ) (positive) or Lead ( $Pb$ ) (negative plate).

**Charging Plug** The male half of a quick connector which contains both the positive and negative leads.

**Charging Rate** The current expressed in amperes at which the battery is charged.

**Charging Receptacle** The female half of a quick connector housing both positive and negative leads.

**Circuit** A system of electrical components through which an electric current is intended to flow. The continuous path of an electric current.

**Compound** An asphaltic, pitchlike material used as a cover-to-jar battery sealant.

**Constant-Current Charge** A charge in which the current is maintained at a constant value. (For some types of lead-acid batteries this may involve two rates called a starting and a finishing rate.)

**Constant Potential Charge**  
See "CONSTANT VOLTAGE CHARGE".

**Constant Voltage Charge** A charge in which the voltage at the terminals of the battery is held at a constant value.

**Container** Housing for one or more cells, commonly called a "JAR".

## GLOSSARY (cont.)

**Cover** The lid or cover of an enclosed cell generally made of the same material as the jar or container and through which extend the posts and the vent plug.

**Cover Inserts** Lead or lead alloy rings which are molded or sealed into the cell cover, and to which are burned the element posts thereby creating an effective acid-creep resistant seal.

**Curing** Chemical conversion process which changes lead oxides and sulfuric acid to mixtures of tetrabasic lead sulfate, other basic lead sulfates, basic lead carbonates, etc., which consequently will form desired structures of Pb or PbO<sub>2</sub> on negative or positive plates during formation.

**Current** The time rate of flow of electricity, normally expressed as amperes, like the flow of a stream of water.

**Cut-Off Voltage**  
See "FINAL VOLTAGE".

**Cutting (of acid)** The dilution of a more concentrated solution of sulfuric acid to a lower concentration.

**Cycle** A discharge and its subsequent recharge.

**Cycle Service** A type of battery operation in which a battery is continuously subjected to successive cycles of charge and discharge, e.g., motive power service.

**Deep Discharge** Removal of up to 80% of the rated capacity of a cell or battery.

**Direct Current (DC)** A direct current is a unidirectional current in which the changes in value are either zero or so small that they may be neglected.

**Discharge** The conversion of the chemical energy of the battery into electrical energy.

**Discharged** The condition of a storage cell when as the result of delivering current, the plates are sulfated, the electrolyte is exhausted, and there is little or no potential difference between the terminals.

**Discharge Rate** Batteries discharged to meet any time rate between 3 hours and 8 hours are considered as having been normally discharged.

**Dry Charging** Manufacturing process whereby charged plates are washed free of acid and then dried.

**Efficiency** The ratio of the output of the cell or battery to the input required to restore the initial state of charge under specified conditions of temperature, current rate and final voltage.

**Electrolysis** Electrochemical reaction which causes the decomposition of a compound, either liquid, molten or in solution.

**Electrolyte** Any substance which disassociates into two or more ions when dissolved in water. Solution of electrolyte conduct electricity and are decomposed by it. In the battery industry the word "electrolyte" implies a dilute solution of sulfuric acid.

**Electromotive Force (EMF)** Electrical pressure or potential, expressed in terms of volts.

**Element** Assembly of a positive plate group, a negative plate group, and separators.

**Equalizing Charge** An extended charge which is given to a storage battery to insure the complete restoration of active materials in all the plates of all the cells.

**Ferroresonant Charger** A constant voltage power supply containing a special transformer-capacitor combination, which changes operating characteristics as current draw is varied, so that the output voltage remains constant.

**Filling Gravity** The specific gravity of acid used in the filling of batteries.

**Final Voltage** The cut-off voltage of a battery; The prescribed voltage reached when the discharge is considered complete.

**Finishing Rate** The rate of charge expressed in amperes to which the charging current for some types of lead batteries is reduced near the end of charge to prevent excessive gassing and temperature rise.

**Fixed Resistance Discharge** A discharge in which the cell or battery is discharged through a fixed resistive load. The current being allowed to fall off as the terminal voltage decreases.

**Flaming** A method used to improve the surface of a cast lead or lead alloy part or of trimmed battery sealing compound in which a flame is passed over the surface causing the material to melt and flow smoothly together.

**Flat Plate** A general term referring to pasted plates.

**Float Charging** Application of a recharge at a very low rate and accomplished by connection to a buss whose voltage is slightly higher than the open circuit voltage of the battery.

**Flush** To add water to a cell.

**Flying Leads** Any fixed terminal cable in which the terminal or plug end of the cable is unsupported and allowed to hang freely along the side of the battery.

**Foot** Portion(s) of the grid projecting from the bottom edge, used for support of the plate group.

**Formation or Forming Charge** An initial charging process during which the raw paste within the plates is electrochemically converted into charged active material, lead peroxide being formed in the positive plates and sponge lead in the negative plates.

**Formed** Plates that have undergone formation are known by this term.

**Freshening Charge** A charge given batteries in storage to replace the standing loss and to ensure that every plate in every cell is periodically brought to a full state of charge.

**Full Charge Gravity** The specific gravity of the electrolyte with the cells fully charged and properly leveled.

**Gang Vent** Vents for usually three adjacent cells which are connected to a common manifold. Typically used on SLI's.

**Gassing** The evolution of gases from one or more of the electrodes during electrolysis.

**Gelled Electrolyte** Electrolyte which has been immobilized by addition of silica powder or other gelling agent.

**Glass Mat** Fabric made from glass fibers with a polymeric binder such as styrene, acrylic, furfural, starch - used to help to retain positive active material.

**Gravity** Refers to specific gravity.

**Gravity Drop** The number of points reduction or drop of the specific gravity of the electrolyte upon discharge of the cell.

**Grid** A metallic framework employed in a storage cell or battery for conducting the electric current and supporting the active material.

**Group** One or more plates of a type (positive or negative) which are burned to a post and strap.

**Hand Stand** Manually operated casting mold into which lead or alloy is manually poured.

**High Impact Rubber**  
See RESIN RUBBER.

**High Rate** On charge, any rate higher than the normal finishing rate.

**H<sub>2</sub>SO<sub>4</sub>** Chemical symbol for Sulfuric Acid.

**Hydration (Lead)** Reaction between water and lead or lead compounds. Lead does not react with strong solutions of sulfuric acid, but gravities lower than those found in discharged cells are apt to produce hydration. Hydration is observed as a white coating on both plate groups and separators in a cell.

**Hydrometer** Device used to indicate density or specific gravity of electrolyte solutions.

**Hydrosot** Curing process for negative and positive plates, wherein free lead in the paste is oxidized and total free lead is reduced to a few per cent.

**Indicator** Devices employed to show a battery's state of charge, or its water level.

**Initial Voltage** The closed-circuit voltage at the beginning of a discharge. It is usually measured after the current has flowed for a sufficient period for the rate of change of voltage to become practically constant.

**Insert** A bushing of lead or lead alloy molded or sealed into cell covers, forming the post hole, and to which the post is burned to create a creep-resistant cover-to-post seal.

**Intercell Connector** Conductor of lead, lead alloy or lead plated copper which is used to connect two battery cells.

## GLOSSARY (cont.)

**Internal Resistance** The resistance within the cell or battery to the flow of an electric current, and is measured by the ratio of the change in voltage at the terminals of the cell or battery corresponding to a specified change in current for short time intervals.

**Jackstraw Mats**  
See GLASS MATS.

**Jar** Cell container, made by injection molding, rota-molding, or thermo-forming.

**Jar Formation** The forming of plates in the cell jar or container, after they have been assembled.

**Jumper** A short length of conductor used to connect or cutout part of an electrical circuit.

**Kilovolt (KV)** One thousand volts.

**Kilowatt (KW)** One thousand watts.

**Kilowatt Hours (KWH)** A measure of energy or work accomplished, being 1000 watt hours.

**Lamp Black** Finely powdered carbon, used as an ingredient in negative plate expander.

**Lead (Pb)** Chemical element used in lead-acid batteries (with sulfuric acid and other materials).

**Lead Burning** Welding of lead or lead alloy parts.

**Lead Hydrate** A white compound of lead of indefinite composition formed by the reaction of very dilute electrolyte or water on metallic lead or lead alloys.

**Lead Oxide** A general term used to describe any of the finely divided lead oxides used to produce paste for storage batteries.

**Lead Peroxide** A brown oxide of lead which is the active material in a fully formed positive plate. Its formula is  $PbO_2$ .

**Lead Plated Part** A metallic part that has had a thin protective layer of metallic lead electrodeposited on its surface.

**Lead Sponge (Pb)** The chief component of the active material of a fully charged negative plate.

**Lead Sulphate ( $PbSO_4$ )** A compound resulting from the chemical action of sulfuric acid on oxides of lead or lead metal itself.

**Level Indicator** A float, mounted in a float tube, or similar indication of the electrolyte level.

**Level Lines** Horizontal lines molded and/or painted near tops of battery jars, which indicate minimum and maximum electrolyte level.

**Life** Number of years of satisfactory float operation or number of charge-discharge cycles for motive power operation.

**Lifting Ear** An extension on the the side walls of a battery tray provided with a hole or slot, by means of which the battery can be lifted.

**Litharge (PbO)** A yellowish-red oxide of lead (monoxide), sometimes used in making active material.

**Local Action** Local action in a battery is the loss of otherwise usable chemical energy by currents which flow within the cell of a battery regardless of its connections to an external circuit.

**Loss of Charge** The capacity loss occurring in a cell or battery standing on open circuit as a result of local action.

**Lug** Portion of grid used for support of the plate group, usually along top edge of grid, as "hanging lug." Also, tab on grid used for connection of plate to strap and other plates.

**Machine Casting** A fully or semi-automatic grid or small parts casting operation.

**Maintenance-Free Battery** Battery which requires no addition of water, no boost charges, etc. This typically requires a non-antimonial or low-antimonial grid alloy, sealed cell design, or low-loss venting.

**Manual Discharge** Capacity test wherein the connection and disconnection of the battery and the test load are done by the operator and the disconnection is made after all cells have reached the prescribed final voltage. With fixed resistance loads, boost cells are used to keep the discharge rate fairly constant as the test cell voltages drop rapidly near the final voltage. Electronic load manual discharges generally do not require boost cells.

**Marine Battery** A battery designed for ship-board installation to provide energy for cranking service and the operation of emergency lighting, alarm, and communication equipment.

**Microporous Separator** Either a veneer or a grooved type separator made of any material in which the pores are numerous and microscopically small.

**Mine Locomotive Battery** A cycle service battery designed to operate mine locomotive, trammer, shuttle cars, and tunnel haulage equipment.

**Millivolt (MV)** One thousandth part of a volt.

**Modified Constant-Voltage Charge** A charge in which the voltage of the charging circuit is held substantially constant; but a fixed resistance is inserted in the battery circuit, producing a rising voltage characteristic at the battery terminals as the charge progresses.

**Mold** A cast iron or steel form which contains the cavity into which molten metal is introduced to produce a casting of definite shape and outline.

**Mold Coat** A preparation applied to metal molds in spray form which acts both as a mold release agent and as an insulator against rapid heat transfer.

**Mold Spray**  
See MOLD COAT.

**Moss** Dendritic crystals of lead (Pb) which sometimes grow at high-current density areas of negative plates, e.g. along edges, at feet, or a plate lugs. May cause a short circuit within cell.

**Moss Shield** Plastic or hard rubber perforate sheet which insulates the gaps between negative plates and the positive strap, and between positive plates and the negative strap.

**Motive Power Battery** A cycle service battery designed to supply the energy necessary to propel and operate electrically powered industrial trucks, street vehicles, and mine locomotives.

**Negative Plate** Consists of the grid and active material to which current flows from the external circuit when the battery is discharging.

**Negative Terminal** The terminal toward which current flows (as ordinarily conceived) in the external circuit from the positive terminal.

**OHM** A unit of electrical resistance.

**One Shot Formation** Jar formation under conditions where end of formation specific gravity is equal to the operating specific gravity.

**Open Circuit** The state of a battery when it is not connected to either a charging source or to a load circuit.

**Open Circuit Voltage** The voltage at its terminals when no appreciable current is flowing.

**Organic Expander** An expander formulation which typically contains barium sulfate and a lignin type organic compound, with small amount of other materials.

**Oxide (of lead)** A compound of lead and oxygen in one of several proportions such as gray oxide, litharge, red lead, or lead peroxide used to prepare battery paste.

**Panel** Casting consisting of two or more grids which has been made simultaneously in a single mold.

**Parallel Assembly** The arrangement of cells within a battery in which two or more cells are connected across a common terminal so that any current flow divides itself between the connected cells.

**Parallel Connection** See PARALLEL ASSEMBLY.

**Partition** An interior dividing wall in a tray or container.

**Paste** Mixture of lead oxide with water, sulfuric acid, and sometimes other ingredients.

**Paste Consistency** A term used to include all of the physical characteristics of the paste density, plasticity and texture.

**Pasting** Battery assembly operation wherein paste is applied to grids by hand or by a machine.

**Pb** Chemical symbol for lead.

## GLOSSARY (cont.)

**PbO** Chemical symbol for litharge.

**PbO<sub>2</sub>** Chemical symbol for lead peroxide (dioxide).

**Pellet** That portion of pasted material contained in a grid section framed by adjacent horizontal and vertical numbers exclusive of forming bars.

**Perforated Retainer** A thin sheet of perforated plastic material installed so as to cover each face of a positive plate to prevent the loss of active material. It is normally used in conjunction with one or more layers of glass insulating material.

**Peroxide**  
See "LEAD PEROXIDE."

**Pig** A cast bar of lead or lead alloy.

**Pig Lead** A grade of highly refined unalloyed lead.

**Pilot Cell** A selected cell of a storage battery whose temperature, voltage, and specific gravity are assumed to indicate the condition of the entire battery.

**Plate** A pasted grid, either formed or unformed.

**Plate Centers** The distance between center lines of adjoining plates of opposite polarity in a cell. The plate center is, therefore, one-half of the size of a strap center upon which the plates of a like polarity are burned.

**Polarity** An electrical condition determining the direction in which current tends to flow. By common usage the discharge current is said to flow from the positive electrode through the external circuit.

**Polarization** The change in voltage at the terminals of the cell or battery when a specified current is flowing, and is equal to the difference between the actual and the equilibrium (constant open circuit condition) potentials of the plates, exclusive of the IR drop.

**Porosity** The ratio of interstices (voids) in a material to the volume of its mass.

**Positive Plates** Consists of the grid and the active material from which current flows to the external circuit when the battery is discharging.

**Positive Terminal** The terminal from which current flows (as ordinarily conceived) through the external circuit to the negative terminal when the cell discharges.

**Post** Terminal or other conductor which connects the plate group strap to the outside of the cell.

**Post Builder** A ring shaped mold used to repair damaged battery posts.

**Potential**  
See VOLTAGE.

**Primary Cell**  
See CELL PRIMARY.

**Pure Lead**  
See PIG LEAD.

**Rated Capacity** The ampere hours of discharge that can be removed from a fully charged secondary cell or battery, at a specific constant discharge rate at a specified discharge temperature and at specified cut off voltage.

**Rate of Charge**  
See "STARTING RATE" "FINISHING RATE".

**Raw Plate** An unformed plate.

**Rectifier** A device which converts alternating current (AC) into unidirectional current (DC) by virtue of a characteristic permitting appreciable flow of current in only one direction.

**Red Lead (Pb<sub>3</sub>O<sub>4</sub>)** A red oxide of lead used in making active material.

**Resistance** The opposition that a conductor offers to the passage of an electrical current, usually expressed in ohms.

**Resistor** A device used to introduce resistance into an electrical circuit.

**Retainer** A sheet of glass mat, perforated or slotted rubber, plastic, or some other satisfactory material installed on each face of the positive plates in certain types of cells, to deter the loss of active material.

**Rib** A vertical or nearly vertical ridge of a grooved separator or spacer.

**Run Down** A small portion of metal that has dropped on to a plate, group or element in the course of burning. It may result in a short circuit.

**Sealing** Manufacturing operation for attaching covers to jars by cement, sealing compound, or thermal fusion.

**Sealing Compound** An asphalt mixture of several types differing in heat resistance, adhesion, and resistance to shearing. It is used for sealing cell covers to the jars or containers. See compound.

**Secondary Lead** Reclaimed lead as opposed to virgin lead.

**Sediment** The leady sludge or active material shed from the plates and found in the bottom of cells.

**Sediment Space** The portion of a jar or container compartment beneath the element, provided to accommodate a certain amount of sediment from the wearing of the plates, without short circuiting.

**Self Discharge** Loss of charge due to local action.

**Separator** A device employed in a storage battery for preventing metallic contact between the plates of opposite polarity within the cell, while allowing passage of electrolyte. See "MICROPOROUS SEPARATOR".

**Separator Protector**  
See "MOSS SHIELD".

**Shedding** Loss of active material from the plates.

**Short Circuit Current** The current which flows when the two terminals of a cell or battery are inadvertently connected to each other.

**SLI Battery** Battery for automotive use in starting, lighting, and ignition.

**Sliver, Slyver** Extremely fine, parallel glass fibers used next to positive plate in retainers, to retard shedding.

**Smelting** The process by which the major portion of lead and antimony are recovered from scrapped batteries and battery manufacture scrap.

**Soaking** A process, whereby certain types of plates are soaked in sulfuric acid, after pasting. Soaking provides a protective surface, and also a supply of sulfate helpful in jar formation and tank formation.

**Soda Ash** Sodium Carbonate (Na<sub>2</sub>CO<sub>3</sub>), used to neutralize effluents containing sulfuric acid, or acid spills.

**Spine** Cast Pb alloy conductor for tubular positive plate.

**Sponge Lead (Pb)** The chief material of a fully charged negative plate. It is a porous mass of lead crystals.

**Stacking** Cell assembly operation wherein plates and separators are alternately piled in a burning box prior to cast-on or burning-on of straps and posts.

**Stacking Fixture or Stacking Jig** The fixture or device used to stack and burn elements.

**Standing Loss** The loss of charge by an idle cell or battery, resulting from local action.

**Starting Rate** The number of amperes at which the charging of a storage battery may be begun without producing gassing or bubbling of the electrolyte, or a cell temperature in excess of 110°F (43°C.)

**State of Charge** The amount of electrochemical energy left in a cell or battery.

**Stationary Battery** A stationary battery is a storage battery designed for service in a permanent position.

**Strap** Precast or cast-on piece of lead or lead alloy used to connect plates into groups and to connect the groups to the post.

**Strap Center** Spacing between centers of adjacent plates in a group.

**Stratification** As applied to electrolyte it is layers of high gravity acid in the lower portions of a cell, where they are out of touch with the ordinary circulation of the electrolyte and thus of no use.

**Sulfated** A term used to describe any plate or cell whose active materials contain an appreciable amount of lead sulfate.

**Sulfation** The formation of lead sulfate on a plate or cell as a result of discharge, self-discharge, or pickling.

**Sulfuric Acid (H<sup>2</sup>SO<sup>4</sup>)** The principal acid compound of sulfur. Sulfuric acid of a high purity and in dilute form is the electrolyte of lead-acid storage cells.

**Tank Formation** The electrolytic processing of plates in large tanks of acid, at a point of manufacture prior to assembly. See also "FORMATION" "DUMMY FORMATION".

## GLOSSARY (cont.)

---

**Temperature Correction** In storage cells, the specific gravity and charging voltage vary inversely with temperature, while the open circuit voltage varies directly (though slightly) with temperature.

**Terminals** The terminals of a battery are the points at which the external circuit is connected.

**Terminal Cable** A length of insulated cable, one of which is connected to the terminal post of a battery, the other end being fitted with a suitable device (plug, receptacle, lug, etc.) for connection to an external circuit.

**Tinning** The process of coating a metal surface with a thin layer of molten tin or tin alloy.

**Tray** Steel enclosure for motive power battery cells.

**Treeing** Growth of a lead dendrite or filament through a hole, crack, or large pore of a separator, whereby the cell is short-circuited.

**Trickle Charge** A trickle charge of a storage battery is a continuous charge at a low rate approximately equal to the internal losses and suitable to maintain the battery in a fully charged condition.

**Tubular Plate** Positive battery plate made from a cast spine and porous tubes which are filled with paste or dry oxide.

**TVR** A temperature compensating voltage relay used in charging equipment.

**Two Rate Charging** An automatically controlled constant current or modified constant potential charging procedure. The charge is begun at a fairly high rate and is automatically reduced to a lower rate when the counter voltage rises to a predetermined level.

**Unactivated Storage Life** The period of time before a dry charged cell deteriorates to have less than a specified capacity.

**Uncharged** The condition of a battery assembled with formed plates but not yet having received its initial charge, are classified either uncharged and moist, or uncharged and dry.

**Uncharged and Dry** A condition in which a battery or cell may be shipped to a customer. This indicates that the battery is assembled with formed plates and dry separators without electrolyte. Filling and a charge are required.

**Uncharged and Moist** A condition in which a battery or cell may be shipped to a customer. Adopted by BCI and indicates that the battery is assembled with formed plates and moist or wet wood separators, without electrolyte. Filling and a long charge are required.

**Unformed** A term used to describe any plate which has not been electrically formed - it may be dry or moist, cured or uncured, soaked or unsoaked.

**Useful Acid** The volume of acid above the lower edges of the plates which takes part in the discharge reactions that occur within a cell.

**Vacuum Cell Filler** A device used to fill cells in the charging room in which a vacuum is used to withdraw the air displaced by the filling electrolyte.

**Vent** An opening provided to permit the escape of gas from a cell or mold.

**Vent Assembly** A cell venting device consisting of a ceramic vent stone and filler funnel assembled on a threaded or a quarter turn bayonet base.

**Vent Baffle** A thin disc located in a vent cap or plug to deflect spray back into the cell.

**Vent Cap**  
See VENT PLUG.

**Vent Plug** The piece or assembly of pieces employed to seal the vent and filling well of a cell cover except for a small hole in the plug itself which permits the escape of gas. Vent plugs are usually held in place either by threads or by a quarter turn catch (bayonet vent plug), or by a snap-in fit.

**Vent Well** The hole or holes in a cell cover through which gas escapes, fluids are added or the electrolyte level is checked. The vent plug or vent assembly fits into the vent well.

**Verticals** The vertical bars of members or members in a pasted plate grid.

**Volt** The practical unit of measurement of electro-motive force or potential difference required to send a current of one ampere through a resistance of one ohm.

**Volt Efficiency** The ratio of the average voltage of cell or battery during discharge to the average voltage during its subsequent recharge.

**Voltage** The difference of potential which exists between the terminals of a cell or battery, or any two points of an electrical circuit.

**Voltage Range** The difference between the maximum and minimum cell voltages that exist within a battery or string of cells when all of the cells are charging or discharging.

**Voltmeter** An instrument for measuring voltage.

**Watering** Adding water to battery electrolyte to replace electrolysis and evaporative losses.

**Watt** A measure of electric power: The product of amperes and volts.

**Watt-hour** A measure of energy or work accomplished, being product of the rate of work in watts and the time in hours, or the product of ampere hours and the average voltage.

**Watt-hour Capacity** The number of watt-hours which can be delivered under specific conditions as to temperature rate of discharge and final voltage.

**Watt-hour Efficiency** The watt-hour efficiency of a storage battery is the energy efficiency expressed as the ratio of the watt-hour output to the watt-hours of the recharge.

**Watt-hour Meter** A watt-hour meter is an electric motor that measures and registers electrical energy in watt-hours (or kilowatt hours).

**Wet Shelf Life** The period of time a wet secondary cell can be stored before its capacity has fallen to the point that the cell cannot be easily recharged.

**Wrapping** Assembly operation wherein motive power positive plates are covered by silver, glass mat, and retainer.





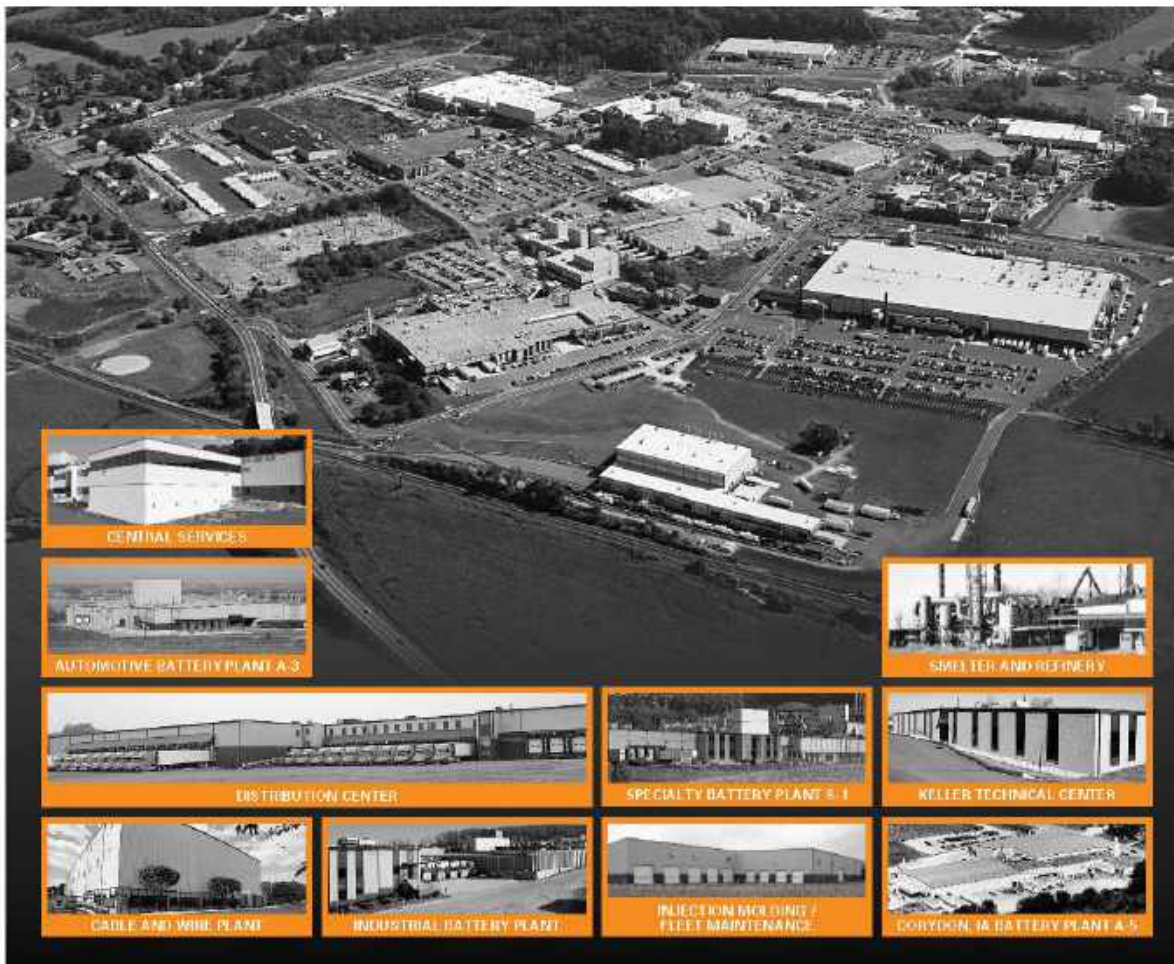

## World's Largest and Most Modern Single-Site Battery Manufacturing Facility

Since 1946, East Penn has been producing high quality batteries and battery accessories for the automotive, commercial, marine, industrial, stationary, and specialty markets.

Facilities at its 520-acre manufacturing complex at Lyon Station, PA include four automotive battery plants, an industrial battery plant, a specialty battery plant, a state-of-the-art oxide facility, an innovative recycling infrastructure, and dozens of vertically integrated capabilities and other support facilities. An additional manufacturing facility in Corydon, IA helps accommodate widespread growth. East Penn owns and operates a wire, cable, and battery accessory plant and a multiple facility distribution center just miles away from its Lyon Station complex.

New high-tech facilities and computer monitoring and control systems have made the company an industry leader in advanced battery manufacturing.

East Penn's quality manufacturing is recognized worldwide and has met the global requirements of ISO 9001 and ISO/TS 16949 certification standards. East Penn is also a leader in innovative recycling and has met global environmental requirements of ISO 14001 certification standards.

Staffed with a long-term management team, East Penn is an independent company committed to the future and dedicated to producing high-class products and service to assure complete satisfaction, above and beyond the industry standard, to our partners and customers worldwide.



e-mail: [epn@eastpenn-dak.com](mailto:epn@eastpenn-dak.com) [www.dakabatteries.com](http://www.dakabatteries.com)



East Penn Manufacturing Co. Lyon Station, PA 10636-0147 Phone: 610-682-6381 Fax: 610-682-4781 Order Hotline: 610-682-3260

E.P.M. Form No. 0656 2/16 © 2016 by EPM Printed in U.S.A.

All data subject to change without notice. No part of this document may be copied or reproduced, electronically or mechanically, without written permission from the company.





## **APPENDIX IV**

### **Battery Safety Data Sheet (SDS)**





**SAFETY DATA SHEET**  
**LEAD ACID BATTERY WET,**  
**FILLED WITH ACID**

**SECTION 1: PRODUCT AND COMPANY IDENTIFICATION**

**PRODUCT NAME:** Lead Acid Battery Wet, Filled With Acid  
**OTHER PRODUCT NAMES:** Electric Storage Battery, UN2794

**MANUFACTURER:** East Penn Manufacturing Company  
**ADDRESS:** Deka Road  
Lyon Station, PA 19536 USA

**EMERGENCY TELEPHONE NUMBERS:** US/CN: CHEMTREC 1-800-424-9300  
Outside US/CN: CHEMTREC 1-703-527-3887

**NON-EMERGENCY HEALTH/SAFETY INFORMATION:** 610-682-6361

**CHEMICAL FAMILY:** This product is a wet lead acid storage battery. May also include gel/absorbed electrolyte lead acid battery types.

**PRODUCT USE:** Industrial/Commercial electrical storage batteries.

**SECTION 2: HAZARDS IDENTIFICATION**

**GHS Classification:**

Health	Environmental	Physical
Acute Toxicity – Category 4 Skin Corrosion – Category 1A Eye Damage – Category 1 Reproductive – Category 1A Carcinogenicity (lead)– Category 1B Carcinogenicity (arsenic)– Category 1A Carcinogenicity(acid mist)–Category1A Specific Target Organ Toxicity (repeated exposure) –Category 2 GHS Label: 	Aquatic Chronic – 1 Aquatic Acute – 1 	Explosive Chemical, Division 1.3 

**Signal Word: DANGER !**



**SAFETY DATA SHEET**  
**LEAD ACID BATTERY WET,**  
**FILLED WITH ACID**

<u>Hazard Statements</u>	<u>Precautionary Statements</u>
<p><b>Health</b> Harmful if swallowed, inhaled, or in contact with skin. Causes severe skin burns and eye damage. Causes serious eye damage. May damage fertility or the unborn child if ingested or inhaled. May cause cancer if ingested or inhaled. Causes damage to central nervous system, blood and kidneys through prolonged or repeated exposure if ingested or inhaled. May cause harm to breast-fed children.</p> <p><b>Environmental</b> Very toxic to aquatic life with long lasting effects.</p> <p><b>Physical</b> May form explosive air/gas mixture during charging. Extremely flammable gas (hydrogen). Explosive; fire, blast or projection hazard. Obtain special instructions before use. Do not handle until all safety precautions have been read and understood.</p>	<p><b>Prevention</b> Wash thoroughly after handling. Do not eat, drink or smoke when using this product. Wear protective gloves/protective clothing, eye protection/face protection. Avoid breathing dust/fume/gas/mist/vapors/spray. Use only outdoors or in a well-ventilated area. Causes skin irritation, serious eye damage. Contact with internal components may cause irritation or severe burns. Avoid contact with internal acid. Irritating to eyes, respiratory system, and skin. Avoid contact during pregnancy/while nursing.</p> <p><b>Response</b> IF SWALLOWED OR CONSUMED: rinse mouth, Do NOT induce vomiting. Call a poison center/doctor if you feel unwell. IF ON CLOTHING OR SKIN (or hair): Remove/Take off immediately all contaminated clothing and wash it before reuse. Rinse skin with water/shower. IF INHALED: Remove person to fresh air and keep comfortable for breathing. Immediately call a POISON CENTER or doctor/physician. IF IN EYES: Rinse cautiously with water for several minutes. Remove contact lenses, if present and easy to do. Continue rinsing. If exposed/concerned, or if you feel unwell seek medical attention/advice.</p> <p><b>Storage and Disposal</b> Store locked up, in a well-ventilated area. In accordance with local and national regulation. Avoid release to the environment. Collect spillage. Dispose of contents/container in accordance with local/regional/national/international regulations. Keep away from heat/sparks/open flames/hot surfaces. No smoking. Use only outdoors or in well ventilated area Keep out of reach of children.</p>

**EMERGENCY OVERVIEW:** May form explosive air/gas mixture during charging. Contact with internal components may cause irritation or severe burns. Irritating to eyes, respiratory system, and skin. Prolonged inhalation or ingestion may result in serious damage to health. Pregnant women exposed to internal components may experience reproductive/developmental effects.

Additional Information  
No health effects are expected related to normal use of this product as sold.

**SECTION 3: COMPOSITION/INFORMATION ON INGREDIENTS**

<u>INGREDIENTS (Chemical/Common Names):</u>	<u>CAS No.:</u>	<u>% by Wt:</u>	<u>EC No.:</u>
Lead and Lead Compounds, inorganic	7439-92-1	43-70 (average: 65)	231-100-4
Electrolyte (Sulfuric acid and water)	7664-93-9	20-44 (average: 25)	231-639-5
Antimony	7440-36-0	0-4 (average: <1)	231-146-5



**SAFETY DATA SHEET**  
**LEAD ACID BATTERY WET,**  
**FILLED WITH ACID**

Polypropylene

9003-07-0

5-10 (average: 8)

NA

NA – Not applicable/ND – Not determined

Additional Information

These ingredients reflect components of the finished product related to performance of the product as distributed into commerce. Inorganic lead, lead compounds and electrolyte (sulfuric acid) are the primary components. Other metals (ie. Sn, Cu, As) may be present at concentrations below the applicable reporting threshold.

**SECTION 4: FIRST AID MEASURES**

- EYE CONTACT:** Sulfuric Acid and Lead: Flush eyes immediately with large amounts of water for at least 15 minutes while lifting lids. Seek immediate medical attention if eyes have been exposed directly to acid.
- SKIN CONTACT:** Sulfuric Acid: Flush affected area(s) with large amounts of water using deluge emergency shower, if available, shower for at least 15 minutes. Remove contaminated clothing, including shoes. If symptoms persist, seek medical attention. Wash contaminated clothing before reuse. Discard contaminated shoes.  
Lead: Wash immediately with soap and water.
- INGESTION:** Sulfuric Acid: Give large amounts of water. Do **NOT** induce vomiting or aspiration into the lungs may occur and can cause permanent injury or death; consult physician.
- INHALATION:** Sulfuric Acid: Remove to fresh air immediately. If not breathing, give artificial respiration. If breathing is difficult, give oxygen. Consult a physician.  
Lead: Remove from exposure, gargle, wash nose and lips; consult physician.

**SECTION 5: FIRE-FIGHTING MEASURES**

**FLASH POINT:** Not Applicable.

**FLAMMABLE LIMITS:** LEL= 4.1% (Hydrogen Gas in air); UEL=74.2%

**EXTINGUISHING MEDIA:** CO<sub>2</sub>; foam; dry chemical. Do not use carbon dioxide directly on cells. Avoid breathing vapors. Use appropriate media for surrounding fire.

**FIRE-FIGHTING PROCEDURES:** Use positive pressure, self-contained breathing apparatus. Beware of acid splatter during water application and wear acid-resistant clothing, gloves, face and eye protection. If batteries are on charge, shut off power to the charging equipment, but note that strings of series connected batteries may still pose risk of electric shock even when charging equipment is shut down.

**HAZARDOUS COMBUSTION PRODUCTS:** Highly flammable hydrogen gas is generated during charging and operation of batteries. If ignited by burning cigarette, naked flame or spark, may cause battery explosion with dispersion of casing fragments and corrosive liquid electrolyte. Carefully follow manufacturer's instructions for installation and service. Keep away all sources of gas ignition and do not allow metallic articles to simultaneously contact the negative and positive terminals of a battery.

Additional Information

Fire-fighting water runoff and dilution water may be toxic and corrosive and may cause adverse environmental impacts.

**SECTION 6: ACCIDENTAL RELEASE MEASURES**

Stop flow of material, contain/absorb small spills with dry sand, earth, and vermiculite. Do not use combustible materials. If possible, carefully neutralize spilled electrolyte with soda ash, sodium bicarbonate, lime, etc. Wear acid-resistant clothing, boots, gloves, and face shield. Do not allow discharge of un-neutralized acid to sewer. Acid must be managed in accordance with approved local, state, and federal requirements. Consult state environmental agency and/or federal EPA.

Additional Information

Lead acid batteries are recyclable. Contact your East Penn representative for recycling information.

**SECTION 7: HANDLING AND STORAGE**

**Handling:** Unless involved in recycling operations, do not breach the casing or empty the contents of the battery. Handle



**SAFETY DATA SHEET**  
**LEAD ACID BATTERY WET,**  
**FILLED WITH ACID**

carefully and avoid tipping, which may allow electrolyte leakage. There may be increasing risk of electric shock from strings of connected batteries. Keep containers tightly closed when not in use. If battery case is broken, avoid contact with internal components. Keep vent caps on and cover terminals to prevent short circuits. Place cardboard between layers of stacked automotive batteries to avoid damage and short circuits. Keep away from combustible materials, organic chemicals, reducing substances, metals, strong oxidizers and water. Use banding or stretch wrap to secure items for shipping.

**Storage:** Store batteries under roof in cool, dry, well-ventilated areas separated from incompatible materials and from activities that may create flames, spark or heat. Store on smooth, impervious surfaces provided with measures for liquid containment in the event of electrolyte spills. Keep away from metallic objects that could bridge the terminals on a battery and create a dangerous short-circuit.

**Charging:** There is a possible risk of electric shock from charging equipment and from strings of series connected batteries, whether or not being charged. Shut-off power to chargers whenever not in use and before detachment of any circuit connections. Batteries being charged will generate and release flammable hydrogen gas. Charging space should be ventilated. Keep battery vent caps in position. Prohibit smoking and avoid creation of flames and sparks nearby. Wear face and eye protection when near batteries being charged.

**SECTION 8: EXPOSURE CONTROLS/PERSONAL PROTECTION**

**Exposure Limits (mg/m<sup>3</sup>)**

Ingredients	OSHA PEL	ACGIH	US NIOSH	Quebec PEV	Ontario OEL	EU OEL
Lead, inorganic	0.05	0.05	0.05	0.05	0.05	0.15 (b)
Antimony	0.5	0.5	0.5	0.5	0.5	0.5 (b,d)
Tin	2	2	2			
Copper	1	1	1	1	1 (a)	0.1 (e)
Arsenic	0.01	0.01	0.01			
Sulfuric Acid	1	0.2	1	1	0.2	0.05 (c)
Polypropylene	N.E.	N.E.	N.E.	N.E.	N.E.	N.E.

(a) As dusts/mists (b) As inhalable aerosol (c) Thoracic fraction (d) Based on OEL's of Austria, Belgium, Denmark, France, Netherlands, Switzerland, & U.K. (e) Based on OEL of Netherlands

**ENGINEERING CONTROLS/SYSTEM DESIGN INFORMATION:**

Store and handle in well-ventilated area. If mechanical ventilation is used, components must be acid-resistant. Handle batteries cautiously, do not tip to avoid spills. Make certain vent caps are on securely. If battery case is damaged, avoid bodily contact with internal components. Wear protective clothing, eye and face protection, when filling, charging, or handling batteries. Do not allow metallic materials to simultaneously contact both the positive and negative terminals of the batteries. Charge batteries in areas with adequate ventilation. General dilution ventilation is acceptable.

**RESPIRATORY PROTECTION (NIOSH/MSHA approved):**

None required under normal conditions. When concentrations of sulfuric acid mist are known to exceed PEL, use NIOSH or MSHA-approved respiratory protection.

**EYE PROTECTION:**

If battery case is damaged, use chemical goggles or face shield.

**SKIN PROTECTION:**

If battery case is damaged, use rubber or plastic acid-resistant gloves with elbow-length gauntlet, acid-resistant apron, clothing and boots.

**OTHER PROTECTION:** In areas where water and sulfuric acid solutions are handled in concentrations greater than 1%, emergency eyewash stations and showers should be provided, with unlimited water supply. Chemically impervious apron and face shield recommended when adding water or electrolyte to batteries.

**Wash Hands after handling.**



**SAFETY DATA SHEET**  
**LEAD ACID BATTERY WET,**  
**FILLED WITH ACID**

Additional Information

- Batteries are housed in polypropylene cases which are regulated as total dust or respirable dust only when they are ground up during recycling. The OSHA PEL for dust is 15 mg/m<sup>3</sup> as total dust or 5 mg/m<sup>3</sup> as respirable dust.
- May be required to meet Domestic Requirements for a Specific Destination(s).

**SECTION 9: PHYSICAL AND CHEMICAL PROPERTIES**

<b>APPEARANCE:</b>	Industrial/commercial lead acid battery
<b>ODOR:</b>	Odorless
<b>ODOR THRESHOLD:</b>	Manufactured article; no apparent odor. Electrolyte is a clear liquid with a sharp, penetrating, pungent odor.
<b>PHYSICAL STATE:</b>	Sulfuric Acid: Liquid; Lead: solid
<b>pH:</b>	~1 to 2
<b>BOILING POINT:</b>	203-240° F (as sulfuric acid)
<b>MELTING POINT:</b>	NA
<b>FREEZING POINT:</b>	NA
<b>VAPOR PRESSURE:</b>	10 mmHg
<b>VAPOR DENSITY (AIR = 1):</b>	> 1
<b>SPECIFIC GRAVITY (H<sub>2</sub>O = 1):</b>	1.215-1.350
<b>EVAPORATION RATE (n-BuAc=1):</b>	< 1
<b>SOLUBILITY IN WATER:</b>	100% (as sulfuric acid)
<b>FLASH POINT:</b>	Below room temperature (as hydrogen gas)
<b>AUTO-IGNITION TEMPERATURE:</b>	NA
<b>LOWER EXPLOSIVE LIMIT (LEL):</b>	4% (as hydrogen gas)
<b>UPPER EXPLOSIVE LIMIT (UEL):</b>	74% (as hydrogen gas)
<b>PARTITION COEFFICIENT:</b>	NA
<b>VISCOSITY (poise @ 25° C):</b>	Not Available
<b>DECOMPOSITION TEMPERATURE:</b>	Not Available

**SECTION 10: STABILITY AND REACTIVITY**

<b>STABILITY:</b>	This product is stable under normal conditions at ambient temperature.
<b>INCOMPATIBILITY (MATERIAL TO AVOID):</b>	<u>Electrolyte:</u> Contact with combustibles and organic materials may cause fire and explosion. Also reacts violently with strong reducing agents, metals, sulfur trioxide gas, strong oxidizers, and water. Contact with metals may produce toxic sulfur dioxide fumes and may release flammable hydrogen gas. <u>Lead compounds:</u> Avoid contact with strong acids, bases, halides, halogenates, potassium nitrate, permanganate, peroxides, nascent hydrogen, and reducing agents. <u>Arsenic compounds:</u> strong oxidizers; bromine azide. NOTE: hydrogen gas can react with inorganic arsenic to form the highly toxic gas-arsine
<b>HAZARDOUS DECOMPOSITION BY-PRODUCTS:</b>	<u>Electrolyte:</u> Sulfur trioxide, carbon monoxide, sulfuric acid mist, sulfur dioxide, hydrogen sulfide. <u>Lead compounds:</u> Temperatures above the melting point are likely to produce toxic metal fume, vapor, or dust; contact with strong acid or base or presence of nascent hydrogen may generate highly toxic arsine gas.
<b>HAZARDOUS POLYMERIZATION:</b>	Will not occur
<b>CONDITIONS TO AVOID:</b>	Prolonged overcharge at high current; sources of ignition.

**SECTION 11: TOXICOLOGICAL INFORMATION**

**ACUTE TOXICITY (Test Results Basis and Comments):**  
Inhalation LD<sub>50</sub>:  
Electrolyte: LC<sub>50</sub> rat 375 mg/m<sup>3</sup> ; LC<sub>50</sub> guinea pig: 510 mg/m<sup>3</sup>



**SAFETY DATA SHEET**  
**LEAD ACID BATTERY WET,**  
**FILLED WITH ACID**

Elemental Lead: Acute Toxicity Point Estimate =4500 ppm V (based on lead bullion)

Elemental Arsenic: No data

Oral LD<sub>50</sub>:

Electrolyte: rat 2140 mg/kg

Elemental Lead: Acute Toxicity Estimate (ATE) = 500mg/kg body weight (based on lead bullion)

Elemental Arsenic: LD<sub>50</sub> mouse: 145 mg/kg

Elemental Antimony: LD<sub>50</sub> rat: 100 mg/kg

**Routes of Entry:** Sulfuric Acid: Harmful by all routes of entry. Lead Compounds: Hazardous exposure can occur only when product is heated, oxidized or otherwise processed or damaged to create dust, vapor or fume. The presence of nascent hydrogen may generate highly toxic arsine gas.

**Inhalation:** Sulfuric Acid: Breathing of sulfuric acid vapors or mists may cause severe respiratory irritation.

Lead Compounds: Inhalation of lead dust or fumes may cause irritation of upper respiratory tract and lungs.

**Ingestion:** Sulfuric Acid: May cause severe irritation of mouth, throat, esophagus and stomach. Lead Compounds: Acute ingestion may cause abdominal pain, nausea, vomiting, diarrhea and severe cramping. This may lead rapidly to systemic toxicity and must be treated by a physician.

**Skin Contact:** Sulfuric Acid: Severe irritation, burns and ulceration. Lead Compounds: Not absorbed through the skin.

Arsenic Compounds: Contact may cause dermatitis and skin hyperpigmentation.

**Eye Contact:** Sulfuric Acid: Severe irritation, burns, cornea damage, and blindness.

Lead Compounds: May cause eye irritation.

**Effects of Overexposure Acute:** Sulfuric Acid: Severe skin irritation, damage to cornea, upper respiratory irritation. Lead Compounds: Symptoms of toxicity include headache, fatigue, abdominal pain, loss of appetite, muscular aches and weakness, sleep disturbances and irritability.

**Effects of Overexposure – Chronic:** Sulfuric Acid: Possible erosion of tooth enamel, inflammation of nose, throat & bronchial tubes. Lead Compounds: Anemia; neuropathy, particularly of the motor nerves, with wrist drop; kidney damage; reproductive changes in males and females. Repeated exposure to lead and lead compounds in the workplace may result in nervous system toxicity. Some toxicologists report abnormal conduction velocities in persons with blood lead levels of 50µg/100 ml or higher. Heavy lead exposure may result in central nervous system damage, encephalopathy and damage to the blood-forming (hematopoietic) tissues.

**Carcinogenicity:** Sulfuric Acid: The International Agency for Research on Cancer (IARC) has classified "strong inorganic acid mist containing sulfuric acid" as a Category I carcinogen, a substance that is carcinogenic to humans. This classification does not apply to liquid forms of sulfuric acid or sulfuric acid solutions contained within a battery. Inorganic acid mist (sulfuric acid mist) is not generated under normal use of this product. Misuse of the product, such as overcharging, may result in the generation of sulfuric acid mist. Lead Compounds: Lead is listed as a 2B carcinogen, likely in animals at extreme doses. Proof of carcinogenicity in humans is lacking at present. Arsenic: Listed by National Toxicology Program (NTP), International Agency for Research on Cancer (IARC), OSHA and NIOSH as a carcinogen only after prolonged exposure at high levels.

**Medical Conditions Generally Aggravated by Exposure:** Overexposure to sulfuric acid mist may cause lung damage and aggravate pulmonary conditions. Contact of sulfuric acid with skin may aggravate diseases such as eczema and contact dermatitis. Lead and its compounds can aggravate some forms of kidney, liver and neurologic diseases.

**Additional Health Data:**

All heavy metals, including the hazardous ingredients in this product, are taken into the body primarily by inhalation and ingestion. Most inhalation problems can be avoided by adequate precautions such as ventilation and respiratory protection covered in Section 8. Follow good personal hygiene to avoid inhalation and ingestion: wash hands, face, neck and arms thoroughly before eating, smoking or leaving the work site. Keep contaminated clothing out of non-contaminated areas, or wear cover clothing when in such areas. Restrict the use and presence of food, tobacco and cosmetics to non-contaminated areas. Work clothes and work equipment used in contaminated areas must remain in designated areas and never taken home or laundered with personal non-contaminated clothing. This product is intended for industrial use only and should be isolated from children and their environment.

The 19<sup>th</sup> Amendment to EC Directive 67/548/EEC classified lead compounds, but not lead in metal form, as possibly toxic to reproduction. Risk phrase 61: May cause harm to the unborn child, applies to lead compounds, especially soluble forms.



**SAFETY DATA SHEET**  
**LEAD ACID BATTERY WET,**  
**FILLED WITH ACID**

**SECTION 12: ECOLOGICAL INFORMATION**

**Environmental Fate:** Lead is very persistent in soil and sediments. No data on environmental degradation. Mobility of metallic lead between ecological compartments is slow. Bioaccumulation of lead occurs in aquatic and terrestrial animals and plants but little bioaccumulation occurs through the food chain. Most studies include lead compounds and not elemental lead.

**Environmental Toxicity:**

**Sulfuric acid:** 24-hr LC<sub>50</sub>, fresh water fish (*Brachydanio rerio*): 82 mg/l  
96-hr LOEC, fresh water fish (*Cyprinus carpio*): 22 mg/l (lowest observable effect concentration)  
**Lead:** 48-hr LC<sub>50</sub> (modeled for aquatic invertebrates): <1mg/L, based on lead bullion  
**Arsenic:** 24-hr LC<sub>50</sub>, freshwater fish (*Carrassius auratus*):>5000g/L

**Additional Information**

- No known effects on stratospheric ozone depletion.
- Volatile organic compounds: 0% (by Volume)
- Water Endangering Class (WGK): NA

**SECTION 13: DISPOSAL CONSIDERATIONS (UNITED STATES)**

**WASTE DISPOSAL METHOD:**

**Spent batteries:** Send to secondary lead smelter for recycling. Contact your East Penn Mfg. representative for more information related to lead acid battery recycling. Spent lead acid batteries are not regulated as hazardous waste when the requirements of 40 CFR Section 266.80 are met. If applicable; EPA hazardous waste number D002 (corrosivity) and D008 (lead). **Electrolyte:** Place neutralized slurry into sealed acid resistant containers and dispose of as hazardous waste, as applicable. Large water diluted spills, after neutralization and testing, should be managed in accordance with approved local, state, and federal requirements. Consult state environmental agency and/or federal EPA. Follow local, State/Provincial, and Federal/National regulations applicable to as-used, end-of-life characteristics to be determined by end-user.

**SECTION 14: TRANSPORT INFORMATION**

DOT rules specified in 49 CFR 173.159 Batteries, wet, regulate the transport of wet spillable batteries. 49 CFR 173.159 (e) specifies that when transported by highway or rail, electric storage batteries containing electrolyte or corrosive battery fluid are not subject to any other requirements of this subchapter, if all of the following are met:

- (1) No other hazardous materials may be transported in the same vehicle;
- (2) The batteries must be loaded or braced so as to prevent damage and short circuits in transit;
- (3) Any other material loaded in the same vehicle must be blocked, braced, or otherwise secured to prevent contact with or damage to the batteries; and
- (4) The transport vehicle may not carry material shipped by any person other than the shipper of the batteries.

If any of these requirements are not met, the batteries must be shipped as fully regulated Class 8 Corrosive hazardous materials.

**GROUND – US-DOT/CAN-TDG/EU-ADR/APEC-ADR:**

Proper Shipping Name	Batteries, Wet, Filled with Acid	ID Number	UN2794
Hazard Class	8	Labels	Corrosive
Packing Group	NA		

**AIRCRAFT – ICAO-IATA:**

Proper Shipping Name	Batteries, Wet, Filled with Acid	ID Number	UN2794
Hazard Class	8	Labels	Corrosive
Packing Group	NA		

Reference IATA packing instructions 870

**VESSEL – IMO-IMDG:**

Proper Shipping Name	Batteries, Wet, Filled with Acid	ID Number	UN2794
Hazard Class	8	Labels	Corrosive
Packing Group	NA		

Reference IMDG packing instructions P801



**SAFETY DATA SHEET**  
**LEAD ACID BATTERY WET,**  
**FILLED WITH ACID**

Additional Information

Transport requires proper packaging and paperwork, including the Nature and Quantity of goods, per applicable origin/destination/customs points as-shipped.

**SECTION 15: REGULATORY INFORMATION**

**INVENTORY STATUS:**

All components are listed on the TSCA; EINECS/ELINCS; and DSL, unless noted otherwise below.

**U.S. FEDERAL REGULATIONS:**

**TSCA Section 8b – Inventory Status:** All chemicals comprising this product are either exempt or listed on the TSCA Inventory.

**TSCA Section 12b – (40 CFR Part 707.60(b))** No notice of export will be required for articles, except PCB articles, unless the Agency so requires in the context of individual section 5, 6, or 7 actions.

**TSCA Section 13 –(40 CFR Part 707.20):** No import certification required (EPA 305-B-99-001, June 1999, Introduction to the Chemical Import Requirements of the Toxic Substances Control Act, Section IV.A)

**RCRA:** Spent Lead Acid Batteries are subject to streamlined handling requirements when managed in compliance with 40 CFR section 266.80 or 40 CFR part 273. If applicable; EPA hazardous waste number D002 (corrosivity) and D008 (lead).

**STATE REGULATIONS (US):** \*Proposition 65 Warning Battery posts, terminals and related accessories contain lead and lead compounds, chemicals known to the State of California to cause cancer and reproductive harm. Batteries also contain other chemicals known to State of California to cause cancer. Wash hands after handling.

**EPA SARA Title III:**

**Section 302 EPCRA Extremely Hazardous Substances (EHS):** Sulfuric acid is a listed "Extremely Hazardous Substance" under EPCRA, with a Threshold Planning Quantity (TPQ) of 1,000 lbs. EPCRA Section 302 notification is required if 500 lbs. or more of sulfuric acid is present at one site (40 CFR 370.10). For more information consult 40 CFR Part 355.

**Section 304 CERCLA Hazardous Substances:** Reportable Quantity (RQ) for spilled 100% sulfuric acid under CERCLA (Superfund) and EPCRA (Emergency Planning and Community Right to Know Act) is 1,000 lbs. State and local reportable quantities for spilled sulfuric acid may vary.

**Section 311/312 Hazard Categorization:** EPCRA Section 312 Tier II reporting is required for non-automotive batteries if sulfuric acid is present in quantities of 500 lbs. or more and/or if lead is present in quantities of 10,000 lbs. or more. For more information consult 40 CFR 370.10 and 40 CFR 370.40.

**Section 313 EPCRA Toxic Substances:** 40 CFR Section 372.38(b) states: If toxic chemical is present in an article at a covered facility, a person is not required to consider the quantity of the toxic chemical present in such article when determining whether an applicable threshold has been met under 40 CFR's 372.25, 372.27, or 372.28 or determining the amount of release to be reported under 40 CFR 372.30. This exemption applies whether the person received the article from another person or the person produced the article. However, this exemption applies only to the quantity of the toxic chemical present in the article.

The reporting of lead and sulfuric acid (and their releases) in leadacid batteries used in cars, trucks, most cranes, forklifts, locomotive engines, and aircraft for the purposes of EPCRA Section 313 is not required. Lead acid batteries used for these purposes are exempt for Section 313 reporting per the "Motor Vehicle Exemption." See page B-22 of the U.S. EPA Guidance Document for Lead and Lead Compound Reporting under EPCRA Section 313 for additional information of this exemption.

Always check your state/local requirements as they may differ.

**Supplier Notification:** This product contains toxic chemicals that may be reportable under EPCRA Section 313 Toxic Chemical Release Inventory (Form R) requirements. For a manufacturing facility under SIC codes 20 through 39, the following information is provided to enable you to complete the required reports:

<u>Toxic Chemical</u>	<u>CAS Number</u>	<u>Approximate % by Weight</u>
Lead	7439-92-1	65
Electrolyte (Sulfuric Acid/Water Solution)	7664-93-9	25
Antimony	7440-36-0	< 1.0
Arsenic	7440-38-2	<0.1



**SAFETY DATA SHEET**  
**LEAD ACID BATTERY WET,**  
**FILLED WITH ACID**

See 40 CFR Part 370 for more details.

Additional Information

This product may be subject to Restriction of Hazardous Substances (RoHS) regulations in Europe and China, or may be regulated under additional regulations and laws not identified above, such as for uses other than described or as-designed/as-intended by the manufacturer, or for distribution into specific domestic destinations.

---

**SECTION 16: OTHER INFORMATION**

---

**OTHER INFORMATION:**

NFPA Hazard Rating for Sulfuric acid:

Flammability (Red) = 0

Health (Blue) = 3

Reactivity (Yellow) = 2

Sulfuric acid is water-reactive if concentrated.

Distribution into Quebec to follow Canadian Controlled Product Regulations (CPR) 24(1) and 24(2).

Distribution into the EU to follow applicable Directives to the Use, Import/Export of the product as-sold.

**SDS PREPARATION INFORMATION:**

DATE OF ISSUE: 13 May 2015

**DISCLAIMER:**

This Safety Data Sheet is based upon information and sources available at the time of preparation or revision date. Information in the SDS was obtained from sources which we believe are reliable, but are beyond our direct supervision or control. We make no Warranty of Merchantability, Fitness for any particular purpose or any other Warranty, Expressed or Implied, with respect to such information and we assume no liability resulting from its use. For this and other reasons, we do not assume responsibility and expressly disclaim liability for loss, damage or expense arising out of or in any way connected with the handling, storage, use or disposal of the product. It is the obligation of each user of this product to determine the suitability of this product and comply with the requirements of all applicable laws regarding use and disposal of this product. For additional information concerning East Penn Manufacturing Co. products or questions concerning the content of this SDS please contact your East Penn representative.





## **APPENDIX V**

### **Curtis Diagnostics and Trouble Shooting**



## 9

## DIAGNOSTICS AND TROUBLESHOOTING

These controllers detect a wide variety of faults or error conditions. Faults can be detected by the operating system or by the VCL code. This section describes the faults detected by the operating system.

Faults detected by VCL code (faults 51–67 in Table 6) cannot be defined here as they will vary from application to application. Refer to the appropriate OEM documentation for information on these faults.

## DIAGNOSTICS

Diagnostics information can be obtained in either of two ways: (1) by reading the display on a 1313 handheld or 1314 PC programmer or (2) by observing the fault codes issued by the Status LEDs. See Table 5 for a summary of LED display formats.

The 1313/1314 programmer will display all faults that are currently set as well as a history of the faults that have been set since the history log was last cleared. The programmer displays the faults by name.

The pair of LEDs built into the controller (one red, one yellow) produce flash codes displaying all the currently set faults in a repeating cycle. Each code consists of two digits. The red LED flashes once to indicate that the first digit of the code will follow; the yellow LED then flashes the appropriate number of times for the first digit. The red LED flashes twice to indicate that the second digit of the code will follow; the yellow LED flashes the appropriate number of times for the second digit.

Example: Battery Undervoltage (code 23).

In the Fault menu of the 1313/1314 programmer, the words **Undervoltage Cutback** will be displayed; the real-time battery voltage is displayed in the Monitor menu (“Keyswitch Voltage”).

The controller’s two LEDs will display this repeating pattern:

RED	YELLOW	RED	YELLOW
*	**	**	***
(first digit)	(2)	(second digit)	(3)

The numerical codes used by the yellow LED are listed in the troubleshooting chart (Table 6), which also lists possible fault causes and describes the conditions that set and clear each fault.

### Summary of LED display formats

The two LEDs have four different display modes, indicating the type of information they are providing.

DISPLAY	STATUS
Neither LED illuminated	Controller is not powered on; or vehicle has dead battery; or severe damage.
Yellow LED flashing	Controller is operating normally.
Yellow and red LEDs both on solid	Controller is in Flash program mode.
Red LED on solid	Internal hardware fault detected by the Supervisor or Primary microprocessor. Missing or corrupt software. Interrupting a software download may cause corruption of the software. Cycle KSI to clear. Reload software or replace controller if necessary.
Red LED and yellow LED flashing alternately	Controller has detected a fault. 2-digit code flashed by yellow LED identifies the specific fault; one or two flashes by red LED indicate whether first or second code digit will follow.

### TROUBLESHOOTING

The troubleshooting chart, Table 6, provides the following information on all the controller faults:

- fault code
- fault name as displayed on the programmer's LCD
- the effect of the fault
- possible causes of the fault
- fault *set* conditions
- fault *clear* conditions.

Whenever a fault is encountered and no wiring or vehicle fault can be found, shut off KSI and turn it back on to see if the fault clears. If it does not, shut off KSI and remove the 35-pin connector. Check the connector for corrosion or damage, clean it if necessary, and re-insert it.

Table 6 TROUBLESHOOTING CHART

CODE	PROGRAMMER LCD DISPLAY EFFECT OF FAULT	POSSIBLE CAUSE	SET/CLEAR CONDITIONS
12	<b>Controller Overcurrent</b> <i>ShutdownMotor;</i> <i>ShutdownMainContactor;</i> <i>ShutdownEMBrake;</i> <i>ShutdownThrottle;</i> <i>FullBrake.</i>	<ol style="list-style-type: none"> <li>External short of phase U, V, or W motor connections.</li> <li>Motor parameters are mis-tuned.</li> <li>Controller defective.</li> <li>Speed encoder noise problems.</li> </ol>	<i>Set:</i> Phase current exceeded the current measurement limit. <i>Clear:</i> Cycle KSI.
13	<b>Current Sensor Fault</b> <i>ShutdownMotor;</i> <i>ShutdownMainContactor;</i> <i>ShutdownEMBrake;</i> <i>ShutdownThrottle;</i> <i>FullBrake.</i>	<ol style="list-style-type: none"> <li>Leakage to vehicle frame from phase U, V, or W (short in motor stator).</li> <li>Controller defective.</li> </ol>	<i>Set:</i> Controller current sensors have invalid offset reading. <i>Clear:</i> Cycle KSI.
14	<b>Precharge Failed</b> <i>ShutdownMotor;</i> <i>ShutdownMainContactor;</i> <i>ShutdownEMBrake;</i> <i>ShutdownThrottle;</i> <i>FullBrake.</i>	<ol style="list-style-type: none"> <li>See Monitor menu » Battery: Capacitor Voltage.</li> <li>External load on capacitor bank (B+ connection terminal) that prevents the capacitor bank from charging.</li> </ol>	<i>Set:</i> Precharge failed to charge the capacitor bank to the KSI voltage. <i>Clear:</i> Cycle Interlock input or use VCL function <i>Enable_Precharge()</i> .
15	<b>Controller Severe Undertemp</b> <i>ShutdownMotor;</i> <i>ShutdownMainContactor;</i> <i>ShutdownEMBrake;</i> <i>ShutdownThrottle;</i> <i>FullBrake.</i>	<ol style="list-style-type: none"> <li>See Monitor menu » Controller: Temperature.</li> <li>Controller is operating in an extreme environment.</li> </ol>	<i>Set:</i> Heatsink temperature below -40°C. <i>Clear:</i> Bring heatsink temperature above -40°C, and cycle interlock or KSI.
16	<b>Controller Severe Overtemp</b> <i>ShutdownMotor;</i> <i>ShutdownMainContactor;</i> <i>ShutdownEMBrake;</i> <i>ShutdownThrottle;</i> <i>FullBrake.</i>	<ol style="list-style-type: none"> <li>See Monitor menu » Controller: Temperature.</li> <li>Controller is operating in an extreme environment.</li> <li>Excessive load on vehicle.</li> </ol>	<i>Set:</i> Heatsink temperature above +95°C. <i>Clear:</i> Bring heatsink temperature below +95°C, and cycle interlock or KSI.
17	<b>Severe B+ Undervoltage</b> <i>Reduced drive torque.</i>	<ol style="list-style-type: none"> <li>See Monitor menu » Battery: Keyswitch Voltage.</li> <li>Non-controller system drain on battery/KSI circuit wiring.</li> <li>KSI disconnected while driving.</li> <li>Blown KSI fuse.</li> </ol>	<i>Set:</i> When below Brownout Voltage for 2 seconds (see Table D-1). <i>Clear:</i> Bring KSI voltage above Brownout Voltage.
17	<b>Severe KSI Undervoltage</b> <i>No Action.</i>	<ol style="list-style-type: none"> <li>See Monitor menu » Battery: Keyswitch Voltage.</li> <li>Non-controller system drain on battery/KSI circuit wiring.</li> <li>KSI disconnected while driving.</li> <li>Blown KSI fuse.</li> </ol>	<i>Set:</i> When below Brownout Voltage for 2 seconds (see Table D-1). <i>Clear:</i> Bring KSI voltage above Brownout Voltage.

Table 6 TROUBLESHOOTING CHART, cont'd

CODE	PROGRAMMER LCD DISPLAY EFFECT OF FAULT	POSSIBLE CAUSE	SET/CLEAR CONDITIONS
18	<b>Severe B+ Overvoltage</b> <i>ShutdownMotor; ShutdownMainContactor; ShutdownEMBrake; ShutdownThrottle; FullBrake.</i>	<ol style="list-style-type: none"> <li>1. See Monitor menu » Battery: Capacitor Voltage.</li> <li>2. Battery menu parameters are misadjusted.</li> <li>3. Battery resistance too high for given regen current.</li> <li>4. Battery disconnected while regen braking.</li> </ol>	<p><i>Set:</i> Capacitor bank voltage exceeded the Severe Overvoltage limit (see page 58) with FET bridge enabled.</p> <p><i>Clear:</i> Bring capacitor voltage below Severe Overvoltage limit, and then cycle KSI.</p>
22	<b>Controller Overtemp Cutback</b> <i>Reduced drive and brake torque.</i>	<ol style="list-style-type: none"> <li>1. See Monitor menu » Controller: Temperature.</li> <li>2. Controller is performance-limited at this temperature.</li> <li>3. Controller is operating in an extreme environment.</li> <li>4. Excessive load on vehicle.</li> <li>5. Improper mounting of controller.</li> </ol>	<p><i>Set:</i> Heatsink temperature exceeded 85°C.</p> <p><i>Clear:</i> Bring heatsink temperature below 85°C.</p>
23	<b>B+ Undervoltage Cutback</b> <i>Reduced drive torque.</i>	<ol style="list-style-type: none"> <li>1. Normal operation. Fault shows that the batteries need recharging. Controller is performance limited at this voltage.</li> <li>2. Battery parameters are misadjusted.</li> <li>3. Non-controller system drain on battery.</li> <li>4. Battery resistance too high.</li> <li>5. Battery disconnected while driving.</li> <li>6. See Monitor menu » Battery: Capacitor Voltage.</li> <li>7. Blown B+ fuse or main contactor did not close.</li> </ol>	<p><i>Set:</i> Capacitor bank voltage dropped below the Undervoltage limit (see page 58) with the FET bridge enabled.</p> <p><i>Clear:</i> Bring capacitor voltage above the Undervoltage limit.</p>
24	<b>B+ Overvoltage Cutback</b> <i>Reduced brake torque.</i> <i>Note: This fault is declared only when the controller is running in regen.</i>	<ol style="list-style-type: none"> <li>1. Normal operation. Fault shows that regen braking currents elevated the battery voltage during regen braking. Controller is performance limited at this voltage.</li> <li>2. Battery parameters are misadjusted.</li> <li>3. Battery resistance too high for given regen current.</li> <li>4. Battery disconnected while regen braking.</li> <li>5. See Monitor menu » Battery: Capacitor Voltage.</li> </ol>	<p><i>Set:</i> Capacitor bank voltage exceeded the Overvoltage limit (see page 58) with the FET bridge enabled.</p> <p><i>Clear:</i> Bring capacitor voltage below the Overvoltage limit.</p>
25	<b>+5V Supply Failure</b> <i>None, unless a fault action is programmed in VCL.</i>	<ol style="list-style-type: none"> <li>1. External load impedance on the +5V supply (pin 26) is too low.</li> <li>2. See Monitor menu » outputs: 5 Volts and Ext Supply Current.</li> </ol>	<p><i>Set:</i> +5V supply (pin 26) outside the +5V±10% range.</p> <p><i>Clear:</i> Bring voltage within range.</p>
26	<b>Digital Out 6 Open/Short</b> <i>Digital Output 6 driver will not turn on.</i>	<ol style="list-style-type: none"> <li>1. External load impedance on Digital Output 6 driver (pin 19) is too low.</li> </ol>	<p><i>Set:</i> Digital Output 6 (pin 19) current exceeded 1 Amp.</p> <p><i>Clear:</i> Remedy the overcurrent cause and use the VCL function <i>Set_DigOut()</i> to turn the driver on again.</p>

**Table 6 TROUBLESHOOTING CHART, cont'd**

CODE	PROGRAMMER LCD DISPLAY EFFECT OF FAULT	POSSIBLE CAUSE	SET/CLEAR CONDITIONS
27	<b>Digital Out 7 Open/Short</b> <i>Digital Output 7 driver will not turn on.</i>	1. External load impedance on Digital Output 7 driver (pin 20) is too low.	<i>Set:</i> Digital Output 7 (pin 20) current exceeded 1 Amp. <i>Clear:</i> Remedy the overcurrent cause and use the VCL function <i>Set_DigOut()</i> to turn the driver on again.
28	<b>Motor Temp Hot Cutback</b> <i>Reduced drive torque.</i>	1. Motor temperature is at or above the programmed Temperature Hot setting, and the current is being cut back. 2. Motor Temperature Control Menu parameters are mis-tuned. 3. See Monitor menu » Motor: Temperature and » Inputs: Analog2. 4. If the application doesn't use a motor thermistor, Temp Compensation and Temp Cutback should be programmed Off.	<i>Set:</i> Motor temperature is at or above the Temperature Hot parameter setting. <i>Clear:</i> Bring the motor temperature within range.
29	<b>Motor Temp Sensor Fault</b> <i>MaxSpeed reduced (LOS, Limited Operating Strategy), and motor temperature cutback disabled.</i>	1. Motor thermistor is not connected properly. 2. If the application doesn't use a motor thermistor, Motor Temp Sensor Enable should be programmed Off. 3. See Monitor menu » Motor: Temperature and » Inputs: Analog2.	<i>Set:</i> Motor thermistor input (pin 8) is at the voltage rail (0 or 10V). <i>Clear:</i> Bring the motor thermistor input voltage within range.
31	<b>Coil1 Driver Open/Short</b> <i>ShutdownDriver1.</i>	1. Open or short on driver load. 2. Dirty connector pins. 3. Bad crimps or faulty wiring.	<i>Set:</i> Driver 1 (pin 6) is either open or shorted. This fault can be set only when Main Enable = Off. <i>Clear:</i> Correct open or short, and cycle driver.
31	<b>Main Open/Short</b> <i>ShutdownMotor; ShutdownMainContactor; ShutdownEMBrake; ShutdownThrottle; FullBrake.</i>	1. Open or short on driver load. 2. Dirty connector pins. 3. Bad crimps or faulty wiring.	<i>Set:</i> Main contactor driver (pin 6) is either open or shorted. This fault can be set only when Main Enable = On. <i>Clear:</i> Correct open or short, and cycle driver.
32	<b>Coil2 Driver Open/Short</b> <i>ShutdownDriver2.</i>	1. Open or short on driver load. 2. Dirty connector pins. 3. Bad crimps or faulty wiring.	<i>Set:</i> Driver 2 (pin 5) is either open or shorted. This fault can be set only when EM Brake Type = 0. <i>Clear:</i> Correct open or short, and cycle driver.
32	<b>EMBrake Open/Short</b> <i>ShutdownEMBrake; ShutdownThrottle; FullBrake.</i>	1. Open or short on driver load. 2. Dirty connector pins. 3. Bad crimps or faulty wiring.	<i>Set:</i> Electromagnetic brake driver (pin 5) is either open or shorted. This fault can be set only when EM Brake Type >0. <i>Clear:</i> Correct open or short, and cycle driver.
33	<b>Coil3 Driver Open/Short</b> <i>ShutdownDriver3.</i>	1. Open or short on driver load. 2. Dirty connector pins. 3. Bad crimps or faulty wiring.	<i>Set:</i> Driver 3 (pin 4) is either open or shorted. <i>Clear:</i> Correct open or short, and cycle driver.
34	<b>Coil4 Driver Open/Short</b> <i>ShutdownDriver4.</i>	1. Open or short on driver load. 2. Dirty connector pins. 3. Bad crimps or faulty wiring.	<i>Set:</i> Driver 4 (pin 3) is either open or shorted. <i>Clear:</i> Correct open or short, and cycle driver.

**Table 6 TROUBLESHOOTING CHART, cont'd**

CODE	PROGRAMMER LCD DISPLAY EFFECT OF FAULT	POSSIBLE CAUSE	SET/CLEAR CONDITION
35	<b>PD Open/Short</b> <i>ShutdownPD.</i>	<ol style="list-style-type: none"> <li>1. Open or short on driver load.</li> <li>2. Dirty connector pins.</li> <li>3. Bad crimps or faulty wiring.</li> </ol>	<i>Set:</i> Proportional driver (pin 2) is either open or shorted. <i>Clear:</i> Correct open or short, and cycle driver.
36	<b>Encoder Fault</b> <i>ShutdownEMBrake;</i> <i>Throttle_Command</i> <i>is not processed</i>	<ol style="list-style-type: none"> <li>1. Motor encoder failure.</li> <li>2. Bad crimps or faulty wiring.</li> <li>3. See Monitor menu » Motor: Motor RPM.</li> </ol>	<i>Set:</i> Motor encoder phase failure detected. <i>Clear:</i> Cycle KSL
37	<b>Motor Open</b> <i>ShutdownMotor;</i> <i>ShutdownMainContactor;</i> <i>ShutdownEMBrake;</i> <i>ShutdownThrottle;</i> <i>FullBrake.</i>	<ol style="list-style-type: none"> <li>1. Motor phase is open.</li> <li>2. Bad crimps or faulty wiring.</li> </ol>	<i>Set:</i> Motor phase U, V, or W detected open. <i>Clear:</i> Cycle KSL
38	<b>Main Contactor Welded</b> <i>ShutdownMotor;</i> <i>ShutdownMainContactor;</i> <i>ShutdownEMBrake;</i> <i>ShutdownThrottle;</i> <i>FullBrake.</i>	<ol style="list-style-type: none"> <li>1. Main contactor tips are welded closed.</li> <li>2. Motor phase U or V is disconnected or open.</li> <li>3. An alternate voltage path (such as an external precharge resistor) is providing a current to the capacitor bank (B+ connection terminal).</li> </ol>	<i>Set:</i> Just prior to the main contactor closing, the capacitor bank voltage (B+ connection terminal) was loaded for a short time and the voltage did not discharge. <i>Clear:</i> Cycle KSI
39	<b>Main Contactor Did Not Close</b> <i>ShutdownMotor;</i> <i>ShutdownMainContactor;</i> <i>ShutdownEMBrake;</i> <i>ShutdownThrottle;</i> <i>FullBrake.</i>	<ol style="list-style-type: none"> <li>1. Main contactor did not close.</li> <li>2. Main contactor tips are oxidized, burned, or not making good contact.</li> <li>3. External load on capacitor bank (B+ connection terminal) that prevents capacitor bank from charging.</li> <li>4. Blown B+ fuse.</li> </ol>	<i>Set:</i> With the main contactor commanded closed, the capacitor bank voltage (B+ connection terminal) did not charge to B+. <i>Clear:</i> Cycle KSL
41	<b>Throttle Wiper High</b> <i>ShutdownThrottle.</i>	<ol style="list-style-type: none"> <li>1. See Monitor menu » Inputs: Throttle Pot.</li> <li>2. Throttle pot wiper voltage too high.</li> </ol>	<i>Set:</i> Throttle pot wiper (pin 16) voltage is higher than the high fault threshold (can be changed with the VCL function <i>Setup_Pot_Faults(i)</i> ). <i>Clear:</i> Bring throttle pot wiper voltage below the fault threshold.
42	<b>Throttle Wiper Low</b> <i>ShutdownThrottle.</i>	<ol style="list-style-type: none"> <li>1. See Monitor menu » Inputs: Throttle Pot.</li> <li>2. Throttle pot wiper voltage too low.</li> </ol>	<i>Set:</i> Throttle pot wiper (pin 16) voltage is lower than the low fault threshold (can be changed with the VCL function <i>Setup_Pot_Faults(i)</i> ). <i>Clear:</i> Bring throttle pot wiper voltage above the fault threshold.
43	<b>Pot2 Wiper High</b> <i>FullBrake.</i>	<ol style="list-style-type: none"> <li>1. See Monitor menu » Inputs: Pot2 Raw.</li> <li>2. Pot2 wiper voltage too high.</li> </ol>	<i>Set:</i> Pot2 wiper (pin 17) voltage is higher than the high fault threshold (can be changed with the VCL function <i>Setup_Pot_Faults(i)</i> ). <i>Clear:</i> Bring Pot2 wiper voltage below the fault threshold.

**Table 6 TROUBLESHOOTING CHART, cont'd**

CODE	PROGRAMMER LCD DISPLAY EFFECT OF FAULT	POSSIBLE CAUSE	SET/CLEAR CONDITIONS
44	<b>Pot2 Wiper Low</b> <i>FullBrake.</i>	<ol style="list-style-type: none"> <li>See Monitor menu » Inputs: Pot2 Raw.</li> <li>Pot2 wiper voltage too low.</li> </ol>	<i>Set:</i> Pot2 wiper (pin 17) voltage is lower than the low fault threshold (can be changed with the VCL function <i>Setup_Pot_Faults()</i> ). <i>Clear:</i> Bring Pot2 wiper voltage above the fault threshold.
45	<b>Pot Low OverCurrent</b> <i>ShutdownThrottle;</i> <i>FullBrake.</i>	<ol style="list-style-type: none"> <li>See Monitor menu » Outputs: Pot Low.</li> <li>Combined pot resistance connected to pot low is too low.</li> </ol>	<i>Set:</i> Pot low (pin 18) current exceeds 10mA. <i>Clear:</i> Clear pot low overcurrent condition and cycle KSL
46	<b>EEPROM Failure</b> <i>ShutdownMotor;</i> <i>ShutdownMainContactor;</i> <i>ShutdownEMBrake;</i> <i>ShutdownThrottle;</i> <i>ShutdownInterlock;</i> <i>ShutdownDriver1;</i> <i>ShutdownDriver2;</i> <i>ShutdownDriver3;</i> <i>ShutdownDriver4;</i> <i>ShutdownPD;</i> <i>FullBrake.</i>	<ol style="list-style-type: none"> <li>Failure to write to EEPROM memory. This can be caused by EEPROM memory writes initiated by VCL, by the CANbus, by adjusting parameters with the programmer, or by loading new software into the controller.</li> </ol>	<i>Set:</i> Controller operating system tried to write to EEPROM memory and failed. <i>Clear:</i> Download the correct software (OS) and matching parameter default settings into the controller and cycle KSL.
47	<b>HPD/Sequencing Fault</b> <i>ShutdownThrottle.</i>	<ol style="list-style-type: none"> <li>KSI, interlock, direction, and throttle inputs applied in incorrect sequence.</li> <li>Faulty wiring, crimps, or switches at KSI, interlock, direction, or throttle inputs.</li> <li>See Monitor menu » Inputs.</li> </ol>	<i>Set:</i> HPD (High Pedal Disable) or sequencing fault caused by incorrect sequence of KSI, interlock, direction, and throttle inputs. <i>Clear:</i> Reapply inputs in correct sequence.
47	<b>Emer Rev HPD</b> <i>ShutdownThrottle;</i> <i>ShutdownEMBrake.</i>	<ol style="list-style-type: none"> <li>Emergency Reverse operation has concluded, but the throttle, forward and reverse inputs, and interlock have not been returned to neutral.</li> </ol>	<i>Set:</i> At the conclusion of Emergency Reverse, the fault was set because various inputs were not returned to neutral. <i>Clear:</i> If EMR_Interlock = On, clear the interlock, throttle, and direction inputs. If EMR_Interlock = Off, clear the throttle and direction inputs.
49	<b>Parameter Change Fault</b> <i>ShutdownMotor;</i> <i>ShutdownMainContactor;</i> <i>ShutdownEMBrake;</i> <i>ShutdownThrottle;</i> <i>FullBrake.</i>	<ol style="list-style-type: none"> <li>This is a safety fault caused by a change in certain parameter settings so that the vehicle will not operate until KSI is cycled. For example, if a user changes the Throttle Type this fault will appear and require cycling KSI before the vehicle can operate.</li> </ol>	<i>Set:</i> Adjustment of a parameter setting that requires cycling of KSI. <i>Clear:</i> Cycle KSL.
51-67	<b>OEM Faults</b> <i>(See OEM documentation.)</i>	<ol style="list-style-type: none"> <li>These faults can be defined by the OEM and are implemented in the application-specific VCL code. See OEM documentation.</li> </ol>	<i>Set:</i> See OEM documentation. <i>Clear:</i> See OEM documentation.

**Table 6 TROUBLESHOOTING CHART, cont'd**

CODE	PROGRAMMER LCD DISPLAY EFFECT OF FAULT	POSSIBLE CAUSE	SET/CLEAR CONDITIONS
68	<b>VCL Run Time Error</b> <i>ShutdownMotor;</i> <i>ShutdownMainContactor;</i> <i>ShutdownEMBrake;</i> <i>ShutdownThrottle;</i> <i>ShutdownInterlock;</i> <i>ShutdownDriver1;</i> <i>ShutdownDriver2;</i> <i>ShutdownDriver3;</i> <i>ShutdownDriver4;</i> <i>ShutdownPD;</i> <i>FullBrake.</i>	<ol style="list-style-type: none"> <li>1. VCL code encountered a runtime VCL error.</li> <li>2. See Monitor menu » Controller: VCL Error Module and VCL Error. This error can then be compared to the runtime VCL module ID and error code definitions found in the specific OS system information file.</li> </ol>	<p><i>Set:</i> Runtime VCL code error condition. <i>Clear:</i> Edit VCL application software to fix this error condition; flash the new compiled software and matching parameter defaults; cycle KSL</p>
69	<b>External Supply Out of Range</b> <i>None, unless a fault action is programmed in VCL.</i>	<ol style="list-style-type: none"> <li>1. External load on the 5V and 12V supplies draws either too much or too little current.</li> <li>2. Fault Checking Menu parameters Ext Supply Max and Ext Supply Min are mis-tuned.</li> <li>3. See Monitor menu » Outputs: Ext Supply Current.</li> </ol>	<p><i>Set:</i> The external supply current (combined current used by the 5V supply [pin 26] and 12V supply [pin 25]) is either greater than the upper current threshold or lower than the lower current threshold. The two thresholds are defined by the External Supply Max and External Supply Min parameter settings (page 53). <i>Clear:</i> Bring the external supply current within range.</p>
71	<b>OS General</b> <i>ShutdownMotor;</i> <i>ShutdownMainContactor;</i> <i>ShutdownEMBrake;</i> <i>ShutdownThrottle;</i> <i>ShutdownInterlock;</i> <i>ShutdownDriver1;</i> <i>ShutdownDriver2;</i> <i>ShutdownDriver3;</i> <i>ShutdownDriver4;</i> <i>ShutdownPD;</i> <i>FullBrake.</i>	<ol style="list-style-type: none"> <li>1. Internal controller fault.</li> </ol>	<p><i>Set:</i> Internal controller fault detected. <i>Clear:</i> Cycle KSL</p>
72	<b>PDO Timeout</b> <i>ShutdownThrottle;</i> <i>CAN NMT State set to Pre-operational.</i>	<ol style="list-style-type: none"> <li>1. Time between CAN PDO messages received exceeded the PDO Timeout Period.</li> </ol>	<p><i>Set:</i> Time between CAN PDO messages received exceeded the PDO Timeout Period. <i>Clear:</i> Cycle KSI or receive CAN NMT message.</p>
73	<b>Stall Detected</b> <i>ShutdownEMBrake;</i> <i>Throttle Command is not processed;</i> <i>Control Mode changed to LOS (Limited Operating Strategy).</i>	<ol style="list-style-type: none"> <li>1. Stalled motor.</li> <li>2. Motor encoder failure.</li> <li>3. Bad crimps or faulty wiring.</li> <li>4. Problems with power supply for the motor encoder.</li> <li>5. See Monitor menu » Motor: Motor RPM.</li> </ol>	<p><i>Set:</i> No motor encoder movement detected. <i>Clear:</i> Either cycle KSI, or detect valid motor encoder signals while operating in LOS mode and return Throttle Command = 0 and Motor RPM = 0.</p>

**Table 6 TROUBLESHOOTING CHART, cont'd**

CODE	PROGRAMMER LCD DISPLAY EFFECT OF FAULT	POSSIBLE CAUSE	SET/CLEAR CONDITIONS
74	<b>Fault On Other Traction Controller</b>	Dual Drive fault; see Dual Drive manual.	
75	<b>Dual Severe Fault</b>	Dual Drive fault; see Dual Drive manual.	
77	<b>Supervisor Fault</b> <i>ShutdownMotor;</i> <i>ShutdownMainContactor;</i> <i>ShutdownEMBrake;</i> <i>ShutdownThrottle;</i> <i>ShutdownInterlock;</i> <i>ShutdownDriver1;</i> <i>ShutdownDriver2;</i> <i>ShutdownDriver3;</i> <i>ShutdownDriver4;</i> <i>ShutdownPD;</i> <i>FullBrake.</i>	<ol style="list-style-type: none"> <li>1. The Supervisor has detected a mismatch in redundant readings.</li> <li>2. Internal damage to Supervisor microprocessor.</li> <li>3. Switch inputs allowed to be within upper and lower thresholds for over 100 milliseconds.</li> </ol>	<i>Set:</i> Mismatched redundant readings; damaged Supervisor; illegal switch inputs. <i>Clear:</i> Check for noise or voltage drift in all switch inputs; check connections; cycle KSL.
78	<b>Supervisor Incompatible</b> <i>ShutdownMotor;</i> <i>ShutdownMainContactor;</i> <i>ShutdownEMBrake;</i> <i>ShutdownThrottle;</i> <i>ShutdownInterlock;</i> <i>ShutdownDriver1;</i> <i>ShutdownDriver2;</i> <i>ShutdownDriver3;</i> <i>ShutdownDriver4;</i> <i>ShutdownPD;</i> <i>FullBrake.</i>	<ol style="list-style-type: none"> <li>1. The main OS is not compatible with the Supervisor OS.</li> </ol>	<i>Set:</i> Incompatible software. <i>Clear:</i> Load properly matched OS code or update the Supervisor code; cycle KSL.
82	<b>Bad Calibrations</b> <i>ShutdownMotor;</i> <i>ShutdownMainContactor;</i> <i>ShutdownEMBrake;</i> <i>ShutdownThrottle;</i> <i>FullBrake.</i>	<ol style="list-style-type: none"> <li>1. Internal controller fault.</li> </ol>	<i>Set:</i> Internal controller fault detection. <i>Clear:</i> Cycle KSL.
83	<b>Driver Supply</b> <i>ShutdownMotor;</i> <i>ShutdownMainContactor;</i> <i>ShutdownEMBrake;</i> <i>ShutdownThrottle;</i> <i>FullBrake.</i>	<ol style="list-style-type: none"> <li>1. Internal controller fault in the voltage supply for the driver circuits.</li> </ol>	<i>Set:</i> Internal controller fault detection. <i>Clear:</i> Cycle KSL.

Table 6 TROUBLESHOOTING CHART, cont'd

CODE	PROGRAMMER LCD DISPLAY EFFECT OF FAULT	POSSIBLE CAUSE	SET/CLEAR CONDITIONS
87	<b>Motor Characterization Fault</b> <i>ShutdownMotor;</i> <i>ShutdownMainContactor;</i> <i>ShutdownEMBrake;</i> <i>ShutdownThrottle;</i> <i>FullBrake.</i>	1. Motor characterization failed during characterization process. See Monitor menu » Controller: Motor Characterization Error for cause: 0=none 1=encoder signal seen, but step size not determined; set Encoder Step Size manually 2= motor temp sensor fault 3= motor temp hot cutback fault 4= controller overtemp cutback fault 5= controller undertemp cutback fault 6= undervoltage cutback fault 7= severe overvoltage fault 8= encoder signal not seen, or one or both channels missing 9= motor parameters out of characterization range.	<i>Set:</i> Motor characterization failed during the motor characterization process. <i>Clear:</i> Correct fault; cycle KSL.
88	<b>Encoder Pulse Count Fault</b> <i>ShutdownMotor;</i> <i>ShutdownMainContactor;</i> <i>ShutdownEMBrake;</i> <i>ShutdownThrottle;</i> <i>ShutdownInterlock;</i> <i>ShutdownDriver1;</i> <i>ShutdownDriver2;</i> <i>ShutdownDriver3;</i> <i>ShutdownDriver4;</i> <i>ShutdownPD;</i> <i>FullBrake.</i>	1. Encoder Steps parameter does not match the actual motor encoder.	<i>Set:</i> Motor lost IFO control and accelerated without throttle command. <i>Clear:</i> Ensure the Encoder Steps parameter matches the actual encoder; cycle KSL.
89	<b>Motor Type Fault</b> <i>ShutdownMotor;</i> <i>ShutdownMainContactor;</i> <i>ShutdownEMBrake;</i> <i>ShutdownThrottle;</i> <i>FullBrake.</i>	1. The Motor_Type parameter value is out of range.	<i>Set:</i> Motor_Type parameter is set to an illegal value. <i>Clear:</i> Set Motor_Type to correct value and cycle KSL.
91	<b>VCL/OS Mismatch</b> <i>ShutdownMotor;</i> <i>ShutdownMainContactor;</i> <i>ShutdownEMBrake;</i> <i>ShutdownThrottle;</i> <i>ShutdownInterlock;</i> <i>ShutdownDriver1;</i> <i>ShutdownDriver2;</i> <i>ShutdownDriver3;</i> <i>ShutdownDriver4;</i> <i>ShutdownPD;</i> <i>FullBrake.</i>	1. The VCL software in the controller does not match the OS software in the controller.	<i>Set:</i> VCL and OS software do not match; when KSI cycles, a check is made to verify that they match and a fault is issued when they do not. <i>Clear:</i> Download the correct VCL and OS software into the controller.

**Table 6 TROUBLESHOOTING CHART, cont'd**

CODE	PROGRAMMER LCD DISPLAY EFFECT OF FAULT	POSSIBLE CAUSE	SET/CLEAR CONDITIONS
92	<b>EM Brake Failed to Set</b> <i>ShutdownEMBrake;</i> <i>ShutdownThrottle.</i> <i>Position Hold is engaged</i> <i>when Interlock=On.</i>	<ol style="list-style-type: none"> <li>1. Vehicle movement sensed after the EM Brake has been commanded to set.</li> <li>2. EM Brake will not hold the motor from rotating.</li> </ol>	<p><i>Set:</i> After the EM Brake was commanded to set and time has elapsed to allow the brake to fully engage, vehicle movement has been sensed.</p> <p><i>Clear:</i> Activate the throttle.</p>
93	<b>Encoder LOS (Limited Operating Strategy)</b> <i>Enter LOS control mode.</i>	<ol style="list-style-type: none"> <li>1. Limited Operating Strategy (LOS) control mode has been activated, as a result of either an Encoder Fault (Code 36) or a Stall Detect Fault (Code 73).</li> <li>2. Motor encoder failure.</li> <li>3. Bad crimps or faulty wiring.</li> <li>4. Vehicle is stalled.</li> </ol>	<p><i>Set:</i> Encoder Fault (Code 36) or Stall Detect Fault (Code 73) was activated, and Brake or Interlock has been applied to activate LOS control mode, allowing limited motor control.</p> <p><i>Clear:</i> Cycle KSI or, if LOS mode was activated by the Stall Fault, clear by ensuring encoder senses proper operation, Motor RPM = 0, and Throttle Command = 0.</p>
94	<b>EMR Rev Timeout</b> <i>ShutdownEMBrake;</i> <i>ShutdownThrottle.</i>	<ol style="list-style-type: none"> <li>1. Emergency Reverse was activated and concluded because the EMR Timeout timer has expired.</li> <li>2. The emergency reverse input is stuck On.</li> </ol>	<p><i>Set:</i> Emergency Reverse was activated and ran until the EMR Timeout timer expired.</p> <p><i>Clear:</i> Turn the emergency reverse input Off.</p>
98	<b>Illegal Model Number</b> <i>ShutdownMotor;</i> <i>ShutdownMainContactor;</i> <i>ShutdownEMBrake;</i> <i>ShutdownThrottle;</i> <i>FullBrake;</i>	<ol style="list-style-type: none"> <li>1. Model_Number variable contains illegal value.</li> <li>2. Software and hardware do not match.</li> <li>3. Controller defective.</li> </ol>	<p><i>Set:</i> Illegal Model_Number variable; when KSI cycles, a check is made to confirm a legal Model_Number, and a fault is issued if one is not found.</p> <p><i>Clear:</i> Download appropriate software for your controller model.</p>
99	<b>Dualmotor Parameter Mismatch</b>	Dual Drive fault: see Dual Drive manual.	





## APPENDIX VI

### Battery Charger Operator/Installer Manual



**WARNING**

Consult local, state or national electric codes for battery charger installation in an aircraft hangar.



# DC POWER TECHNOLOGIES

TOMORROW'S TECHNOLOGY FOR TODAY'S APPLICATION

OPERATOR / INSTALLER MANUAL

MODULAR CHARGER

# FS5

&

MODULAR CHARGER

# FS4



**XHP** eco  
**SERIES** CHARGE



# WARNINGS



Keep open flames away from batteries on charge.



Risk of battery explosion.



Be aware of battery fumes and electrolyte.



Do not dispose of batteries in the garbage.

**Pb**



Electrical hazard exists inside the charger, do not remove the side cover.



Always recycle lead acid batteries.

**Pb**



Battery electrolyte is highly corrosive.



Wear eye protection when working near batteries.

# Contents

Warnings .....	2
Contents .....	3
Overview .....	4
Installation .....	5
Operation .....	6
- Front Panel .....	8
- Configuration Settings .....	10
Charger Alarms .....	11
Battery Alarms .....	13
Troubleshooting .....	15
Maintenance .....	17
Spare Parts .....	18
Service & Warranty .....	20
Specifications .....	21

<b>Charger Serial Number</b>	
<b>Charger Part Number</b>	
<b>Date Supplied</b>	
<b>Vehicle Model</b>	
<b>Purchaser</b>	
<b>Purchase Invoice Number</b>	
<b>Fleet Number</b>	

# Overview

- 1 Controller Display
- 2 Controller Push Buttons
- 3 AC Input (Rear)
- 4 Mini USB Port
- 5 START/STOP Rocker Switch
- 6 Small LED Indicators
- 7 READY/CHARGING Indicator Lights
- 8 Filter Cover Assembly
- 9 DC Output



FS5 & FS9 XHF Series Charger

# Installation

## Location

The recommended installation is where the charger(s) can be located at ground level or on a raised platform, protected against accidental contact with the lift truck or its forks. Installation above ground level is recommended to reduce the level of dust ingested by the charger.

## AC Input

The FS5 and FS9 chargers require 480V, 3 phase AC supply. Care must be taken to install your charger with the appropriate rated AC supply cable.

FS5: 6 AWG Copper Conductors

FS9: 6 AWG Copper Conductors, rated 167°F / 75°C minimum

Refer to the rating label on your charger for AC supply requirements specific to your configuration.

## AC Supply Wiring Configuration

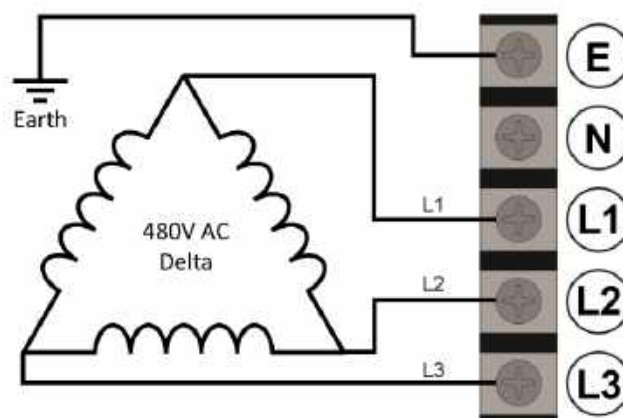

**Note:** It is common in the US that a fourth wire (neutral) be used in a triple phase circuit. If present, it should be attached to the "E" terminal.

# Operation

The XHF Series charger can be paired with a battery-mounted module\* allowing automatic charge-configuration of the charger as well as additional data logging features. The battery module is required for any FS9 charger, or any XHF Series charger configured for Fast or High Rate charging. Refer to your battery module manual for correct installation and operation of your battery module with this charger.

- 1 Check the battery leads are in good condition before proceeding.
- 2 Set the rocker switch to **STOP**.
- 3 Plug the charger in and turn on the AC supply.
- 4 Check that the Voltage, Ampere-Hr and Battery Type indicated on the charger display is appropriate for the battery to be charged. BMID equipped batteries will automatically configure the charger provided the charger has APC configuration enabled.
- 5 Connect the battery to the charger using the correct cable.
- 6 Set the rocker switch to **START**.
- 7 The red **CHARGING** light will illuminate to indicate charging has commenced.
- 8 When the green **READY** light illuminates, charging is complete.
- 9 Set the rocker switch to **STOP** and then disconnect the battery from the charger.

\* A battery module may be either an Automatic Profile Configuration (APC) module or a Battery Monitoring Module (BMM).



# Front Panel

1





## Controller display

Displays information depending on the status of the charger.

2

## Controller push buttons (Set Equalize Charge)

To enable equalize next cycle, plug in the battery but before setting the rocker switch to **START**:

- Press  button to set equalize next cycle
- Press ENTER to allow changing
- Press  to select "Enable"
- Press ENTER to accept change
- Press  to select "Store"
- Press ENTER to accept
- Press  to return to "Connect Battery"
- Set the rocker switch to **START**

3

## Mini USB port

4

## START/STOP rocker switch

0 = Stop charge.

1 = Start charge.

5

## READY/CHARGING indicator lights

RED steady on, GREEN off = Charging.

RED off, GREEN steady on = Charge complete.

RED flashing, GREEN off = Non-Urgent Alarm.

RED flashing, GREEN flashing = Urgent Alarm.



When a Non-Urgent Alarm is indicated the charge cycle has still completed and in most cases can be disregarded.

When an Urgent Alarm is indicated, the charge cycle has not been completed and the occurrence should be reported to a supervisor.



**RED LED** same as RED indicator.

**AMBER LED** same as GREEN indicator.

**GREEN LED** illuminates when charger is powered up.



**UP** button.

**ENTER** button.

**DOWN** button.

**Display when no battery connected or rocker switch set to *STOP*.**

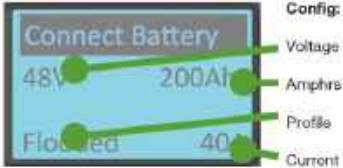

**Display when charging.**



**Display when charge complete.**



# Configuration Settings

## Charge Profiles Available:

- Conventional Charge IU1a/IE1
- Opportunity Charge
- Fast Charge (battery module required)

**Battery Types:** Flooded, Sealed, Gel.

**Environments:** Standard, Freeze/cold condition.

**Cable Length:** Combined charger and battery cable length in metres.

## Equalize Charge Settings:

*Cycle count:* Adjustable to any number. Default setting is to equalize charge after every 5 complete charge cycles.

*Day/time:* Select day and time of the week to trigger an equalize charge on the next charge cycle. Can also select to have it equalize charge every other week.

*Manual equalize:* Select to have an equalize charge run from the display panel.

**Contact your local Eco Charge / Dealer for assistance with the adjustment of these settings.**

## Ampere-Hour Ranges:

	FS5		FS9	
	Low limit (Ahr)	Upper Limit (Ahr)	Low limit (Ahr)	Upper Limit (Ahr)
<b>Conventional Profile (16A/100Ahr)</b>				
<b>24V</b>	300	1875	300	3375
<b>36V</b>	300	1875	300	3375
<b>48V</b>	300	1575	300	2810
<b>Opportunity Profile (25A/100Ahr)</b>				
<b>24V</b>	300	1200	300	2160
<b>36V</b>	300	1200	300	2160
<b>48V</b>	300	1000	300	1800
<b>Fast Profile (40A/100Ahr)</b>				
<b>24V</b>	300	750	300	1350
<b>36V</b>	300	750	300	1350
<b>48V</b>	300	625	300	1125

# Charger Alarms

Inlet Filter	APC Water Level Low	Mains Fail	Monitor ADC Fail
Low Mains	APC Voltage Imbalance	Configuration Error	Urgent Module Fail
Module Fan Fail	Main Switch	Output Fuse	APC Communications Fail
Non-Urgent Module Fail	Module Over Temperature	No Output Current	Urgent Module Fail

**Inlet Filter.** Non-Urgent Alarm, can give warning as to when the inlet filter needs servicing but is not enabled by default.

**Low Mains.** Non-Urgent Alarm, gives an indication of variation in the input mains voltage without actually affecting the ability of the charger to provide rated output. Can also indicate a charger module being overloaded.

**Module Fan Fail.** Non-Urgent Alarm, in the event of a complete failure of the cooling fans the effected module will back off the maximum output current available to level where natural convection of heat will allow the module to continue operating.

**Non-Urgent Module Fail.** Non-Urgent Alarm, there is a charger module that is not providing output but the charger is still operating, but redundancy has been lost.

**APC Water Level Low.** Non-Urgent Alarm, for APC equipped batteries, indicates the APC Electrolyte Sensor has detected a low level of electrolyte.

**APC Voltage Imbalance.** Non-Urgent Alarm, for APC equipped batteries, indicates the midpoint voltage varies from nominal by more than 0.5V. APC will schedule an equalize charge to rectify this variation.

**Main Switch.** Urgent Alarm, shows the status of the front panel START/STOP rocker switch.

**Module Over Temperature.** Urgent Alarm, normally related to a blocked filter or restricted exhaust air or installation in an inappropriate location.

## Charger Alarms - continued

**Mains Fail.** Urgent Alarm, a mains loss situation and the charge cannot proceed.

**Configuration Error.** Urgent Alarm, the charger cannot meet the target current required by the controller even with all fitted charger modules operating or the configuration does not meet the limits set for the selected AC supply.

**Output Fuse.** Urgent Alarm, a blown fuse in nearly all cases is caused by connecting a reverse polarity battery to the charger. When a fuse is blown, check all batteries for reverse cable connection. A common problem is with first charge of shift batteries that have not been previously tested in a lift truck. After replacing a battery or charger cable always closely check the polarity before plugging the battery onto the charger.

**No Output Current.** Urgent Alarm, the charger is not providing the expected output current. Generally related to a premature disconnection of the battery, but also could be an incorrectly inserted charger module.

**Monitor ADC Fail.** Urgent Alarm, internal watchdog of the controller's micro-controller indicating a major fault and potentially unpredictable behaviour if the charger is left running.

**APC Communications Fail.** Urgent Alarm, the APC module has failed to communicate with the charger.

**APC Incorrect Voltage.** Urgent Alarm, the charger cannot produce the voltage required by the APC.

**APC Unknown Charger.** Urgent Alarm, the charger cannot find the required profile required by APC.

**Urgent Module Fail.** Urgent Alarm, if the number of charger modules not providing output equals or exceeds the setting for urgent module count in the monitor tab then the charger will stop. If urgent module count is set to one then the charger is configured without redundancy and a single fault will interrupt the charge cycle.

# Battery Alarms

Deeply Discharged Battery	Batt Over Temp - Charge	Sulphated Battery	Bulk Charge Timeout
Finishing Charge Timeout	Minimum Current	Incorrect Battery	Batt Over Temp - Start
Minimum dV/dt	EQ/Refresh Timeout	Battery Disconnected	+dI/dt
Maximum Cell Voltage	Over Discharged Battery	Reversed Battery	

**Deeply Discharged Battery.** Non-Urgent Alarm, the battery at start is under 1.9V per cell but recovers within 30 secs of charge, normally comes up when the battery is quickly unplugged from the lift truck and plugged into the charger.

**Finishing Charge Timeout.** Non-Urgent Alarm, the battery has exceeded the maximum time allowed for the finishing part of the charge cycle. Generally not a major problem and indicates the battery did not quite perform as expected. Not uncommon with new batteries that are still cycling up to full capacity (allow 10 cycles) however if the alarm is a regular occurrence it needs investigation and possible adjustment of the charger or service of the battery.

**Minimum dV/dt.** Non-Urgent Alarm, details the change in battery voltage over time. The alarm occurs when the change in voltage exceeds the value set in profile settings. This alarm also indicates the termination of a successful charge.

**Maximum Cell Voltage.** Non-Urgent Alarm, occurs when the voltage per cell exceeds the value set in the profile settings. Typically 2.7V per cell for lead acid batteries.

**Batt Over Temp - Charge.** Non-Urgent Alarm, occurs when the battery temperature measured during a charge profile exceeds the value set in the controller settings. This alarm will not allow the charge profile to continue.

**Minimum Current.** Non-Urgent Alarm, occurs when using a IU profile and the current in the constant voltage stage falls below the value set in the profile settings. This alarm will not stop a profile and is considered normal for some types of batteries.

**EQ/Refresh Timeout.** Non-Urgent Alarm, occurs when the time in a given stage of the equalize profile has exceeded the value set for that stage of the profile. This alarm will terminate the equalize charge but is not considered an Urgent Alarm.

## Battery Alarms - continued

**Over Discharged Battery.** Urgent Alarm, the battery is still under 1.9V per cell after 30 seconds of charge which indicates a faulty battery that needs investigation.

**Sulphated Battery.** Urgent Alarm, deactivated by default.

**Incorrect Battery.** Urgent Alarm, the battery voltage is inappropriate for the configuration of the charger and cannot be charged without reconfiguring the charger to suit the battery. Note: An incorrectly configured APC can cause this alarm.

**Battery Disconnected.** Urgent Alarm, the battery has been unplugged before charge cycle has completed. This can damage the battery connector and increase risks of battery explosions as sparks around batteries at their top of charge whilst gassing can be very dangerous. If the battery needs to be disconnected mid cycle, the toggle switch must be first set to STOP. This will stop the charge and log a partial cycle in the charge log but allows safe disconnection of the battery.

**Reversed Battery.** Urgent Alarm, a battery with positive and negative cables reversed has been connected to the charger. Generally this will also cause an output fuse alarm and the need to replace the charger's DC output fuse(s). Such a situation is not covered by warranty as new batteries should always first be checked for correct polarity BEFORE plugging onto the lift truck or a charger.

**Bulk Charge Timeout.** Urgent Alarm, the battery has exceeded the maximum time allowed for the initial constant current bulk charge phase. Could indicate a faulty battery or the charger configuration is not correct for the size of battery to be charged. May need additional charger modules added to the charger.

**Batt Over Temp - Start.** Urgent Alarm, occurs when the battery temperature measured before a charge profile starts exceeds the value set in the controller settings. This alarm will not allow the charge profile to continue.

**+dI/dt. Urgent Alarm,** occurs when the measured current in the constant voltage stage is rising instead of falling. This alarm will terminate the charge profile.

# Troubleshooting

Problem	Possible Cause	Remedy
Main Switch Alarm	Front panel switch in the STOP position.	Charge will start when the switch is set to START.
Inlet Filter Alarm	Air inlet filter blocked.	Clean the filter.
Low Mains Alarm	AC mains supply is low or charger modules may be overloaded.	Check configuration of the charger suits the application.
Non-Urgent Module Fail Alarm	Charger module not providing output, there is capacity to charge at a reduced rate.	Replace the faulty charger module(s).
Urgent Module Fail Alarm	Faulty charger modules are affecting the ability of the charger to charge the battery.	Replace the faulty charger module(s).
Module Fan Fail	Faulty charger module fan.	Replace charger module.
Module Over Temperature	Charger module is overheating.	Check air inlet filter is not blocked, check the charger is installed without any obstructions to air inlet and outlet.
Configuration Error	Charger cannot provide the target output current.	Check the controller configuration matches the quantity of power modules installed, add charger modules if necessary. BMID/battery requires more current than modules or AC supply can support.
Output Fuse	Blown output fuse.	Check battery polarity. Replace blown fuse.
No Output Current	Charger failing to provide the required current.	Check operator has not been unplugging battery mid charge cycle or the charge profile has allowed the battery current to fall below 0.7A.
Monitor ADC Fail	Faulty MPC35 controller module.	Replace the MPC35 controller module ensuring the replacement is correctly configured.

## Troubleshooting - continued

Problem	Possible Cause	Remedy
Low Output Current	Only one battery cable connected (FS9).	Ensure two battery cables are connected (FS9 only).
Over Discharged Battery	Battery is <1.9Vpc at connection but recovers within 30 seconds of charge.	Allow approximately 1 minute between truck-battery disconnect and charger-battery connect. Regular occurrences might need investigation of work practices.
No Output Current	Battery unplugged during charge.  Charge profile allows current to fall below 0.7A	Ensure battery has not been unplugged before charge completion. Check that the charge profile is appropriate for the battery type.
Deeply Discharged Battery	Battery is still <1.9Vpc after 30 seconds of charge.	Check battery for faults.
Incorrect Battery	Battery is not the correct voltage for the charger.	Check the configuration matches the battery.
Bulk Charge Timeout	The bulk charge part of the cycle is longer than expected.	Check the charger configuration matches the battery, check the battery for problems.
Finishing Charge Timeout	The finishing charge part of the cycle is longer than expected.	Check that the charger configuration matches the battery, regular timeouts may indicate a problem with the battery.
Battery Disconnected	Battery has been disconnected during charge cycle.	Front panel toggle switch must be set to STOP before disconnecting battery.
Reversed Battery	A reverse polarity battery has been connected to the charger.	Correct the incorrect battery wiring and replace the blown charger output fuse(s).

# Maintenance

Provided it is correctly installed in an appropriate location and is not abused, the charger will require little maintenance. The only requirement is to monitor the air inlet filter at the front of the charger for dirt accumulation. The charger modules internal to the charger housing require a good supply of cooling air during the charge cycle and a blocked filter will affect the cooling. A blocked filter could lead to the charger turning down its maximum output to prevent overheating of the charger modules. An extremely blocked filter could cause longer charge times, inability to charge the battery correctly or premature wear of the charger modules.

## Service Interval

The recommended service interval is 6 months but this will vary depending on the location of the charger and the number of charge cycles performed. The fans in the charger modules only run during charging and are speed controlled. If the charger output is small the fans will only be turning slowly. At full power there is a considerable requirement for cooling air and the fans will be working hard with considerable hot air being exhausted from the rear of the charger. The exhaust air from the rear of the charger should never be restricted. The intermittent nature of the fans results in a long fan service with no scheduled replacement of fans being required.

## Intake Filter

The filter material is an electrostatic polypropylene type that is easy to clean with compressed air to blow out any accumulated dirt and dust. Before attempting to clean the filter it is necessary to remove it from the housing by unscrewing the two captive screws and unhinging the filter from the housing. The electrostatic filters provide a good compromise between filtering and clogging, but a small quantity of dust will enter the charger modules during normal operation. A small quantity of dust in the charger modules will generally not cause problems, however excessive accumulation or where the material ingested is corrosive, conductive or wet will cause issues, resulting in premature wear of the charger modules.



# Spare Parts



















Image	Description
	MP330 Module
	SM31 Large Display Assembly
	MPC35 Main Board Assembly
	300A Current Shunt
	Current Sense Loom
	Voltage Sense Loom
	FS5-9 AC Filter Board
	Auxiliary PSU
	Stud Diode 240A 400V
	Fuse HRC180A 150VDC 240VAC
	Front Control Panel Membrane
	USB Hole Plug

Image	Description
	FS5 Cabinet
	FS9 Cabinet
	Blanking Plate - Module Bay
	Welded Filter Assembly
	Front Panel Green Indicator
	Front Panel Red Indicator
	Front Panel Rocker Switch

# Service & Warranty

## Service

If both the RED and GREEN indicators are flashing there has been an Urgent Alarm that has prevented the charge cycle from completing. Take note of the error displayed on the display and contact your servicing battery dealer or call DC Power Technologies (DCPT) at 1-844-ECO-CHRG for assistance.

If the RED indicator is flashing, but the GREEN indicator is on steadily, the charge has completed satisfactorily but with a Non-Urgent Alarm. Contact DCPT only if this is occurring on a regular basis.

## Warranty

DCPT warrants that the product is free from defects in material and workmanship and agrees to remedy any defect (or at its option replace the product) for a period of one year from the date of purchase. This warranty covers both parts and labour. Parts may be replaced under this warranty with new or remanufactured parts.

This warranty will not apply to any product that has been improperly installed, misused, abused, used in ways the product was not designed, altered or repaired in any way which may affect the performance or reliability of operation, sustained damage by power surges or electrical storms, or sustained shipping damage, or repaired by any unauthorised repair center.

Please contact DCPT Customer Service to obtain a Returned Materials Authorisation (RMA) prior to shipping any products for repair. All shipments must be shipped prepaid and include proof of the date of your original purchase. Please include your name, address, phone number, email address and a brief description of the problem.

DCPT makes no other warranties, express or implied, including any warranty of fitness for a particular purpose. In no event shall DCPT be responsible for indirect or consequential damages or lost profits even if DCPT has been advised of the possibility of such damages. DCPT's sole obligation shall be the repair or replacement of a nonconforming product.

# Warranty Certificate

## ECO Charger FS3, FS5, FS9

DC Power Technologies Inc. warrants that this product is free from defects in the material and workmanship and agrees to remedy any defect (or at its option replace the product).

This warranty will not apply to any product that has been improperly installed (as described in the installation manual), misused, abused, used in the ways the product was not designed, altered or repaired in any way which may affect the performance or reliability of operation, sustained damage by power surges or electrical storms, or sustained shipping damage, or repaired by any unauthorized repair center.

This warranty covers both parts and labor. Parts may be replaced under this warranty with new or remanufactured parts.

1. **Products and Parts Warranted.** Subject to the exceptions listed below each Industrial Battery Charger is warranted for a specific period of time commencing from the date of sale by DC Power Technologies Inc. provided the charger is used in accordance with Enatel's Installation manual and instruction booklet. Exceptions to this warranty are as follows :

### A. Terms and Conditions

Full Coverage, labor, travel, mileage & part replacement	2 years
Electronic parts only (fuses not included)	4 years

- B. **Warranty Expense Limitation :** The maximum warranty expense DCPT will incur for any battery charger will be limited to the original purchase price of the battery charger.
- C. AC Fuses, DC Fuses are not warranted unless found to be defective from the factory shipment.
2. **Commencement of Warranty Time Period.** The warranty periods indicated in the warranty schedule shall commence on the date of the sale from DC Power Technologies Inc.
3. **Persons Covered By Warranty.** DC Power Technologies Inc. extends this warranty only to the purchaser of the new equipment from DCPT or one of its authorized distributors. The products purchased under this agreement shall be used exclusively by the buyer and its employees and by no other persons; and therefore there shall be no third party beneficiary to this warranty.
4. **Altered Equipment.** Exception as authorized in writing, the warranty specified does not cover any equipment that has been altered by any party other than DCPT or its authorized dealer.

DC Power Technologies Inc. or Enatel Motive Power Ltd. Make no other warranties, express or implied, including any warranty of fitness for a particular purpose. In no event shall Enatel Motive Power or DCPT be responsible for indirect or consequential damages or lost profits even if Enatel Motive3 Power Ltd. Or DCPT have been advised of the possibility of such damages. Enatel Motive Power Ltd's / DCPT sole obligation to you shall be the repair or replacement of a non-conforming product.

**WARNING :** At all times safety must be considered an important factor in the installation, serving and operation of the product and skilled, qualified technical assistance should be utilized.

12432 Highway 99 Suite 72  
Everett, WA 98204

Phone : 844-ECO-CHRG  
[www.DCPowerTechnologies.com](http://www.DCPowerTechnologies.com)



TOMORROW'S TECHNOLOGY FOR TODAY'S APPLICATION

# Specifications

## FS5 & FS9 Cabinet

Dimensions (in / cm): 13.40W x 18.0D x 26.00H / 340W x 45.7D  
x 66.0H

Weight (lbs / kg):

Empty:	71.0	/ 32.2 (approx.)
FS5 (5 modules)	95.4	/ 43.3
FS9 (9 modules)	123.0	/ 55.8

## MP330 Modules

AC Input Three phase 480V  
Nominal Input Voltage: 380-480V AC  
Operating Voltage Range: 340-580V AC  
Frequency Range: 45-65Hz >0.92PF  
Typical Efficiency: Max. 93% @ 48V  
DC Output Range: 25-65V DC  
60A DC output up to 50V  
52A DC output to 57.6V  
Ripple: <2mV  
Broadband Noise: 2mV (<100hz)  
200mV p-p (0-22Mhz)

## Environmental Requirements

Ambient Temp. Range: -50°F to 104°F  
(max. output power is derated above 122°F)  
Storage Temperature: -68°F to 158°F  
Humidity: 5-95% RH (non-condensing)

## Compliances

UL Listed: E333392 - UL 1564

California Appliance  
Efficiency Program: Large Battery  
Charger Systems



# Specifications

## FS5 & FS9 Cabinet

Dimensions (in / cm): 13.40W x 18.0D x 26.00H / 340W x 45.7D  
x 66.0H

Weight (lbs / kg):

Empty:	71.0	/ 32.2 (approx.)
FS5 (5 modules)	95.4	/ 43.3
FS9 (9 modules)	123.0	/ 55.8

## MP330 Modules

AC Input Three phase 480V  
Nominal Input Voltage: 380-480V AC  
Operating Voltage Range: 340-580V AC  
Frequency Range: 45-65Hz >0.92PF  
Typical Efficiency: Max. 93% @ 48V  
DC Output Range: 25-65V DC  
60A DC output up to 50V  
52A DC output to 57.6V  
Ripple: <2mV  
Broadband Noise: 2mV (<100hz)  
200mV p-p (0-22Mhz)

## Environmental Requirements

Ambient Temp. Range: -50°F to 104°F  
(max. output power is derated above 122°F)  
Storage Temperature: -68°F to 158°F  
Humidity: 5-95% RH (non-condensing)

## Compliances

UL Listed: E333392 - UL 1564

California Appliance  
Efficiency Program: Large Battery  
Charger Systems



# Notes

# Notes

Contact your local dealer :



12432 Highway 99 Everett, WA 98204

Phone : 1-844-ECO-CHRG

Fax : 206-745-6077

[www.DCPowerTechnologies.com](http://www.DCPowerTechnologies.com)



Manufactured by :



Copyright © 2013 Enatel Motive Power



## **APPENDIX VII**

### **Flat Sling Inspection**





# WARNING

IF ANY DAMAGE SUCH AS THE FOLLOWING IS VISIBLE, THE SLING SHALL BE REMOVED FROM SERVICE IMMEDIATELY.

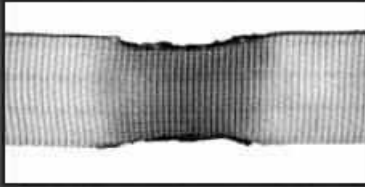

ACID OR CAUSTIC BURNS



CUTS



EDGE CUT

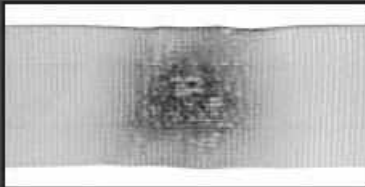

MELTING OR CHARRING

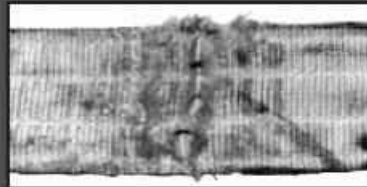

ABRASIONS

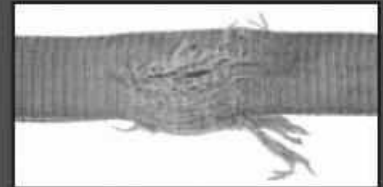

PUNCTURES



WELD SPATTER

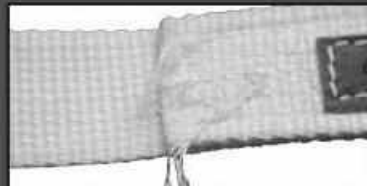

BROKEN OR WORN STITCHES



DAMAGED EYE



EMBEDDED MATERIALS



TENSILE BREAK



MISSING OR ILLEGIBLE TAGS

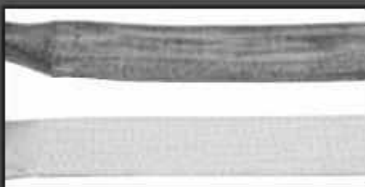

UV DEGRADATION

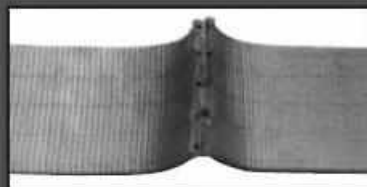

RED CORE YARNS



KNOTS

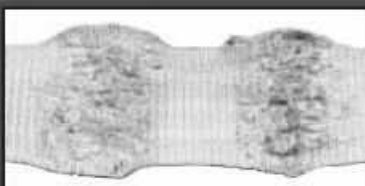

CRUSHED WEBBING



SNAGS



DISTORTED HARDWARE





## **APPENDIX VIII**

**Royco 756 (MIL-PRF-5606)  
Safety Data Sheet (SDS)**









## **APPENDIX IX**

### **Declaration of Conformity**





## DECLARATION of CONFORMITY

The design, development and manufacture is in accordance with European Community guidelines

Towbarless Tug  
eJP-12  
eJP-12SP

Relevant provisions complied with by the machinery:  
2006/42/EC  
EN 1915-1  
EN 12312-7

Relevant standards complied with by the machinery:  
EN ISO 12100-1

Identification of person empowered to sign on behalf of the Manufacturer:

A handwritten signature in black ink that reads "Patrick Finch". The signature is written in a cursive style and is positioned above a solid horizontal line.

Quality Assurance Representative