



OPERATION & SERVICE MANUAL



Model: 07-3000-0922
Defueler

01/2011 – Rev.01

Includes Illustrated Parts List

REVISION
01

DATE
01/2011

TEXT AFFECTED
Original Release



TABLE OF CONTENTS

	<u>PAGE</u>
1.0 GENERAL DESCRIPTION	1
2.0 SPECIFICATIONS	1
3.0 PREPARATION FOR USE	1
4.0 OPERATION	1
4.1 USAGE	1
4.2 MISCELLANEOUS.....	1
5.0 PROVISION OF SPARES.....	2
5.1 SOURCE OF SPARE PARTS.....	2
5.2 RECOMMENDED SPARE PARTS LISTS	2
6.0 GUARANTEES/LIMITATION OF LIABILITY	2
7.0 APPENDICES	2

This product can not be modified without the written approval of Tronair, Inc. Any modifications done without written approval voids all warranties and releases Tronair, Inc., its suppliers, distributors, employees, or financial institutions from any liability from consequences that may occur. Only Tronair OEM replacement parts shall be used.

1.0 GENERAL DESCRIPTION

The Tronair Defueler is designed to provide a safe and efficient way to defuel aircraft. In the process, fuel is cleaned and water removed.

2.0 SPECIFICATIONS

- Overall Height: 41"
- Overall Width: 34-3/8"
- Overall Depth: 25-3/4"
- Weight: 140 pounds
- Finish: Tronair Blue Acrylic Enamel
- Welded cart with 12" diameter wheels
- Tool Tray
- Air operated diaphragm pump
 - 15 GPM maximum flow
 - 50 PSI maximum operating pressure
- 50 PSI Safety valve
- Air inlet control valve
- ½ micron fuel filtration (98% particle removal efficiency)
- 20 foot and 50 foot static discharge reels
- 15 foot suction hose with shutoff valve
- 40 foot discharge hose with aircraft fueling nozzle
- Various suction hose adaptors
- Totalizer, gallon measure, resettable

3.0 PREPARATION FOR USE

The Tronair Defueler is shipped fully assembled and is ready to use after unpacking. Generally inspect unit and check fittings for tightness after shipment.

- Install proper size male end ship air quick 1/4 inch pipe nipple located at air inlet control valve. **Male quick disconnect fitting not provided with unit.**

4.0 OPERATION

4.1 USAGE

To use your Defueler, follow these steps below:

- a. Attach one static discharge cable clamp to ground point of aircraft or holding tank the fuel is to be pumped from.
- b. Attach the other static discharge cable clamp to ground point of aircraft or holding tank the fuel is to be pumped to.



CAUTION!

To prevent possible explosion, static discharge cable must be connected to proper grounds.

- c. Select proper suction fitting or hose to be used and securely fasten (or insert in) to aircraft or holding tank.
- d. With suction, discharge, and air inlet valves closed, connect shop air hose to Defueler.
- e. Regulate pressure to 50 PSIG maximum.
- f. Open suction valve.
- g. Open air inlet valve.
- h. Insert discharge tube onto the storage tank that is to be receiving the fuel, and slowly open discharge valves.

NOTE: Fuel flow can be controlled by either the air control valve (primary control) or the discharge hose aircraft nozzle (Secondary control).

4.2 MISCELLANEOUS

The pump can run "dry" without damage, therefore, to rid defueler hoses of as much fuel as possible leave pump operate until fuel flow ends from discharge tube.

NOTE: If a loss in flow is noticed, the filter elements are becoming blocked off with dirt. When flow is cut drastically, replace elements.

Defueler is not for resale use!

NOTE: For aviation fuel service please refer to cartridge operating procedures that are supplied with each cartridge shipment.



5.0 PROVISION OF SPARES

5.1 SOURCE OF SPARE PARTS

Spare parts may be obtained from the manufacturer:

TRONAIR, Inc.

1 Air Cargo Pkwy East

Swanton, Ohio 43558 USA

Telephone: (419) 866-6301 or 800-426-6301

Fax: (419) 867-0634

E-mail: sales@tronair.com

Website: www.tronair.com

5.2 RECOMMENDED SPARE PARTS LISTS

Reference the following page(s) for Replacement Parts and Kits available.

6.0 GUARANTEES/LIMITATION OF LIABILITY

Tronair products are warranted to be free of manufacturing or material defects for a period of one year after shipment to the original customer. This is solely limited to the repair or replacement of defective components. This warranty does not cover the following items:

- a) Parts required for normal maintenance
- b) Parts covered by a component manufacturers warranty
- c) Replacement parts have a 90-day warranty from date of shipment

If you have a problem that may require service, contact Tronair immediately. Do not attempt to repair or disassemble a product without first contacting Tronair, any action may affect warranty coverage. When you contact Tronair be prepared to provide the following information:

- a) Product Model Number
- b) Product Serial Number
- c) Description of the problem

If warranty coverage is approved, either replacement parts will be sent or the product will have to be returned to Tronair for repairs. If the product is to be returned, a Return Material Authorization (RMA) number will be issued for reference purposes on any shipping documents. Failure to obtain a RMA in advance of returning an item will result in a service fee. A decision on the extent of warranty coverage on returned products is reserved pending inspection at Tronair. Any shipments to Tronair must be shipped freight prepaid. Freight costs on shipments to customers will be paid by Tronair on any warranty claims only. Any unauthorized modification of the Tronair products or use of the Tronair products in violation of cautions and warnings in any manual (including updates) or safety bulletins published or delivered by Tronair will immediately void any warranty, express or implied.

The obligations of Tronair expressly stated herein are in lieu of all other warranties or conditions expressed or implied. **Any unauthorized modification of the Tronair products or use of the Tronair products in violations of cautions and warnings in any manual (including updates) or safety bulletins published or delivered by Tronair will immediately void any warranty, express or implied and Tronair disclaims any and all liability for injury (WITHOUT LIMITATION and including DEATH), loss or damage arising from or relating to such misuse.**

7.0 APPENDICES

APPENDIX I	Lincoln Diaphragm Pump Series "A" Owner/Operator Manual
APPENDIX II	Static Discharge Grounding Reel Installation/Operation Instruction
APPENDIX III	Differential Pressure Gauge
APPENDIX IV	Fill-Rite 807CN Meter Owner/Operator Manual

Additional Documents:

Velcon Band Clamp Assembly Installation Instructions for VF-61

Velcon Filter Information for 512 PL1/2

Parts List

When ordering replacement parts/kits, please specify model, serial number and color of your unit.

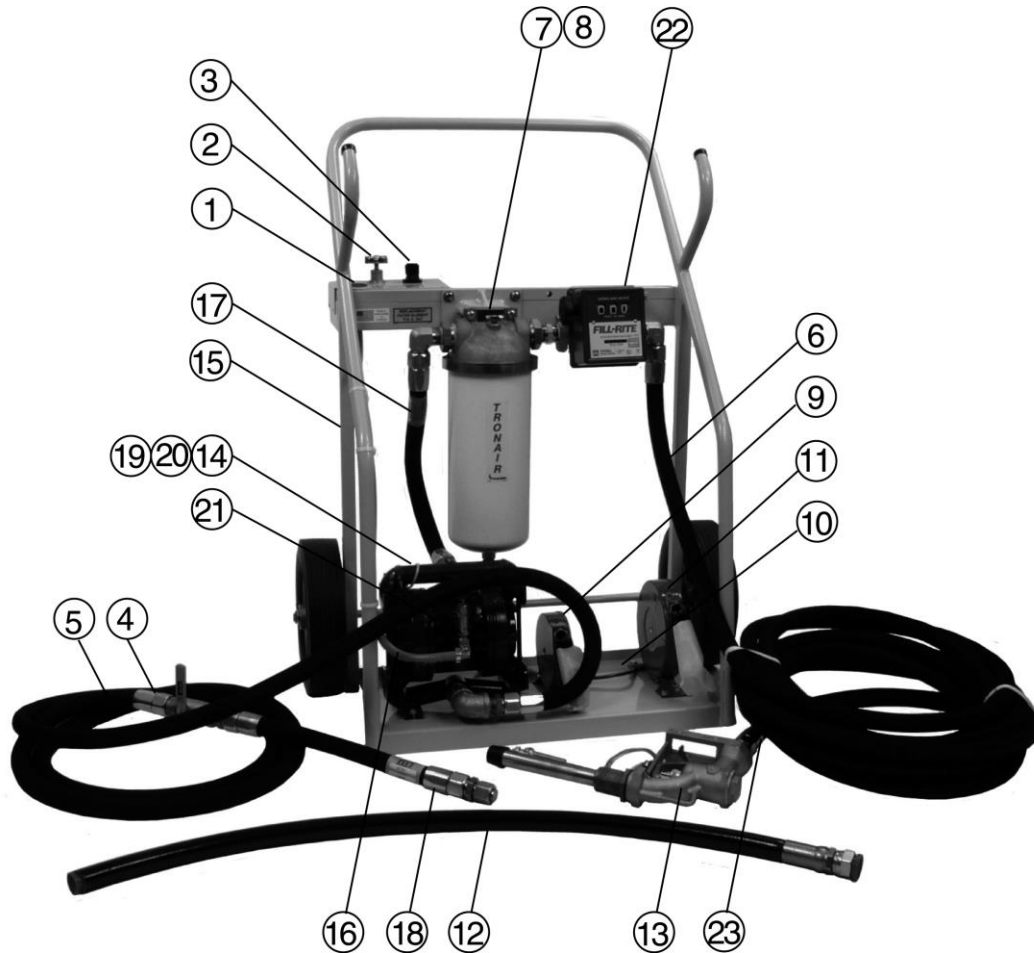

Item	Part Number	Description	Qty
1	HC-1831	Gauge, Pressure	1
2	HC-1081-01	Assembly, Needle Valve (See Page 5)	1
3	H-1397	Regulator	1
4	HC-1119	Valve, Ball, 1" NPT	1
5	TF-1050-02*180	Assembly, Suction Hose	1
6	TF-1050-02*480	Assembly, Discharge Hose	1
7	Z-5037	Assembly, Filter	1
9	H-1187	Reel, Static Discharge, 20 foot	1
10	EC-1572-02*09.0	Wire, Electrical 4 Awg Grn/Ylw (Requires 2 EC-1034-13 per Wire)	2
11	H-1186	Reel, Static Discharge, 50 foot	1
12	TF-1051-01*48.0	Hose, Suction Adapter	1
13	H-2876	Nozzle, Aircraft Fuel	1
**14	Z-4256	Assembly, Pump	1
15	H-2477-01	Cart	1
16	TF-1064-06*36.0	Hose, 3/8" I.D. x 36" long	1
17	TF-1050-02*23.0	Hose	1
18	TF-1050-02*18.0	Assembly, Suction Hose	1
21	PC-1017-02-50	Valve, Safety	1
22	H-3101	Totalizer, Gallon Measure	1
23	H-2877	Swivel	1

Parts List

When ordering replacement parts/kits, please specify model, serial number and color of your unit.

Item	Part Number	Description	Qty
8	K-4035	Kit, Filter Element Replacement; consists of:	
	H-2938	Element, Filter	1
	HC-2000-257	O-ring, Series 2	1
19	K-3181	Kit, (Pump) Diaphragm; consists of:	
		O-ring, Valve Seal (Reference Lincoln Literature)	4
		Diaphragm (Reference Lincoln Literature)	2
20	K-3182	Kit, (Pump) Air Valve Seal; consists of:	
		Gasket, Air Valve (Reference Lincoln Literature)	1
		O-ring, Air Valve Cap (Reference Lincoln Literature)	2
		O-ring, Center Block (Reference Lincoln Literature)	4
N/S	K-4033	Kit, Differential Pressure Gauge; consists of:	
	H-2944	Pressure Gauge	1
	INS-1853	Instructions	1

** See attached Lincoln Pump parts list. Lincoln Pump Model 85634 with BUNA-N seals.

Parts List - Needle Valve Assembly

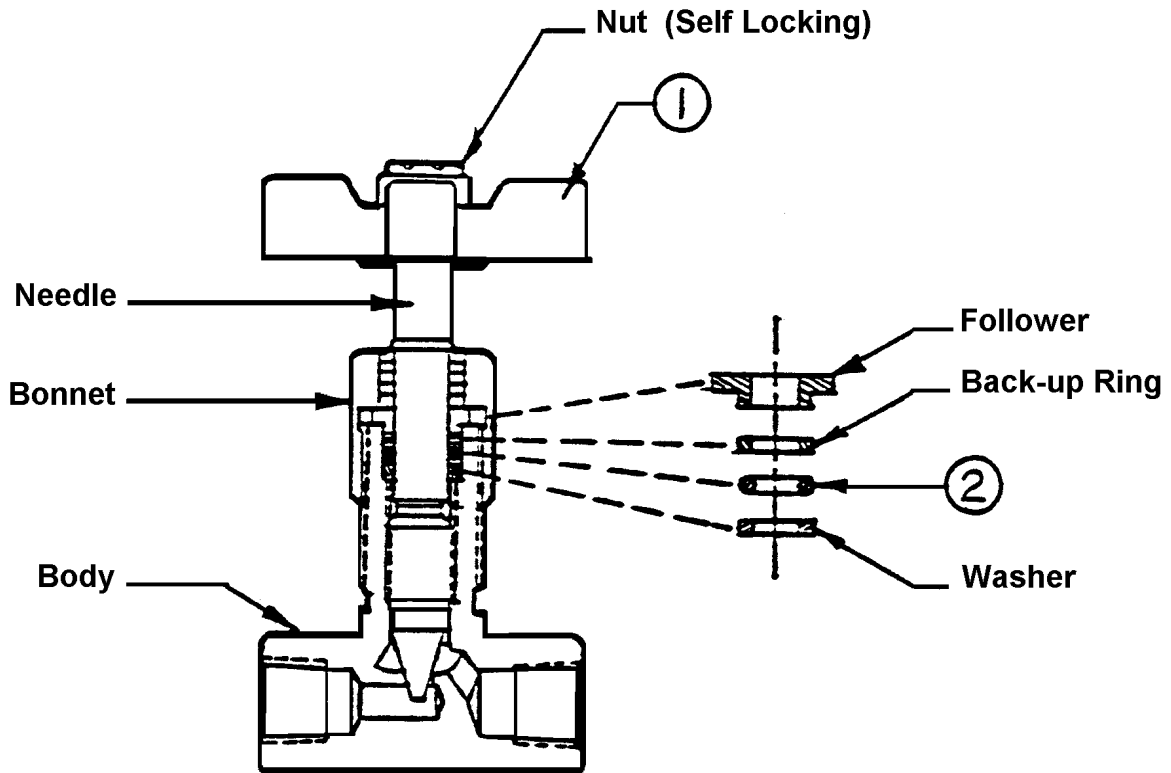

Item	Part Number	Description	Qty
1	HC-1082	Handle, Valve	1
2	HC-2000-011 (2-011-N674-70)	O-ring	1



APPENDIX I

Lincoln Diaphragm Pump Series "A" Owner/Operator Manual

SERVICE & OPERATING MANUAL



**Models 85634 & 85635
1" Aluminum UL Listed Double Diaphragm Pump**

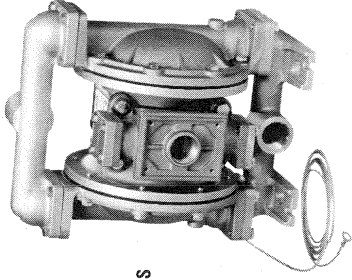

II 2GD b T5



U.S. Patent #
5,996,627
Other U.S. Patents
Applied for

Table of Contents

Engineering Data and Temperature Limitations	1	Composite Repair Parts List	10
Performance Curve	2	Air Distribution Valve Assembly Drawing and Parts List	11
Dimensions	3	Air Distribution Valve Servicing	12
Metric Dimensions	4	Pilot Valve Servicing, Assembly Drawing & Parts List	13
Principle of Pump Operation	5	Diaphragm Service Drawing, with Overlay	14
Installation and Start-Up	5	Diaphragm Service Drawing, Non-Overlay	14
Air Supply	5	Diaphragm Servicing	15
Air Valve Lubrication	5	Overlay Diaphragm Servicing	15
Air Line Moisture	5	Actuator Plunger Servicing	16
Air Inlet and Priming	5	Check Valve Servicing	17
Between Uses	5	Check Valve Drawing	17
Installation Guide	6	Muffler Drawing and Provision for Piping Air Exhaust	18
Troubleshooting	7	Pumping Hazardous Liquids	18
Warranty	7	Converting Pump for Piping Exhaust Air	18
Recycling	8	Converted Exhaust Illustration	18
Important Safety Information	8	Grounding The Pump	19
Composite Repair Parts Drawing	9		
Available Service and Conversion Kits	9		



Models 85634 & 85635

Air-Powered Double-Diaphragm Pump

ENGINEERING, PERFORMANCE & CONSTRUCTION DATA

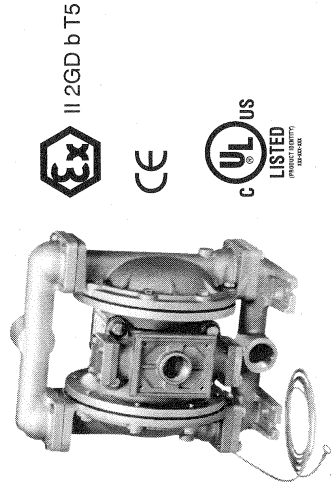

U.S. Patent #
5,996,627
Other U.S. Patents
Applied for

INTAKE/DISCHARGE PIPE SIZE 1" NPT(Internal) 1" BSPT Tapered (Internal)	CAPACITY 0 to 45 gallons per minute (0 to 170 liters per minute)	AIR VALVE No-leak, no-stall design	SOLIDS-HANDLING Up to .25 in. (6mm)	HEADS UP TO 125 psi or 289 ft. of water (8.6 Kg/cm ² or 86 metres)	DISPLACEMENT/STROKE .11 Gallon / .42 liter	Operating Temperatures	
						Maximum	Minimum
						190°F 88°C	-10°F -23°C
						170°F 77°C	-10°F -23°C
						212°F 100°C	-35°F -37°C
						150°F 65°C	-40°F -40°C
						180°F 82°C	-40°F -40°C

CAUTION! Operating temperature limitations are as follows:
Materials

Buna General purpose, oil-resistant. Shows good solvent, oil, water and hydraulic fluid resistance. Should not be used with highly polar solvents like acetone and MEK, ozone, chlorinated hydrocarbons and nitro hydrocarbons.

Neoprene All purpose. Resistant to vegetable oil. Generally not affected by moderate chemicals, fats, greases and many oils and solvents. Generally attacked by strong oxidizing acids, ketones, esters, nitro hydrocarbons and chlorinated aromatic hydrocarbons.

Virgin PTFE Chemically inert, virtually impervious. Very few chemicals are known to react chemically with molten alkali metals, turbulent liquid or gaseous fluorine and a few fluoro-chemicals such as chlorine trifluoride or oxygen difluoride which readily liberate free fluorine at elevated temperatures.

Polypropylene

Polyethylene

For specific applications, always consult a "Chemical Resistance Chart"

Performance Curve, Models 85634 & 85635

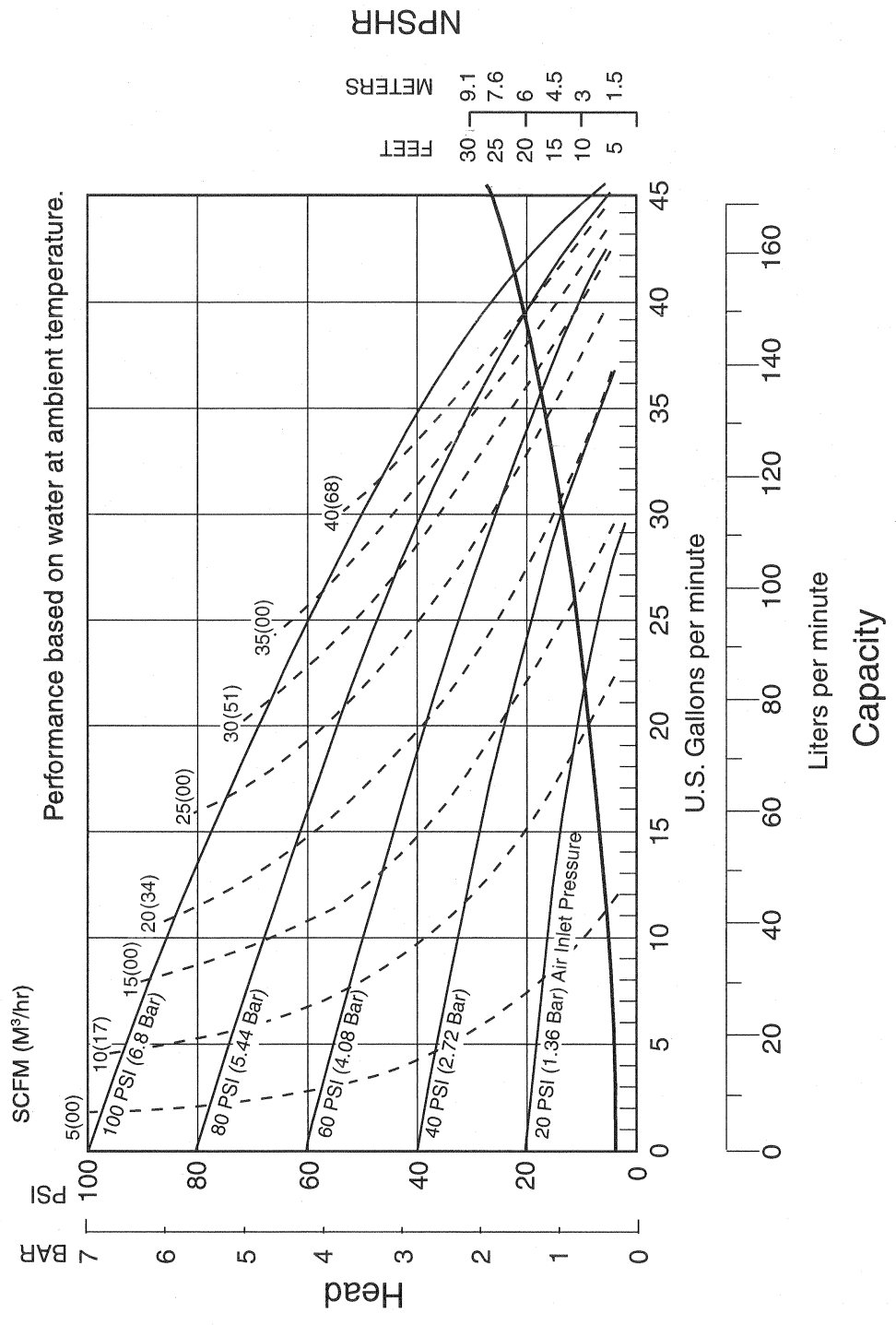

Dimensions: Models 85634 & 85635

Dimensions in Inches
Dimensional Tolerance: $\pm 1/8"$

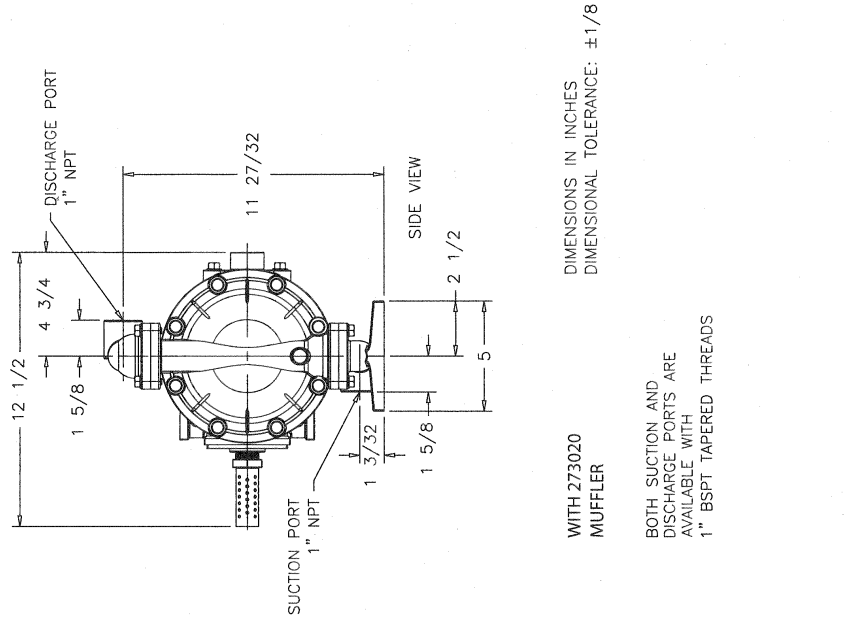

Metric Dimensions: 85634 & 85635

Dimensions in Millimeters
Dimensional Tolerance: ± 3mm

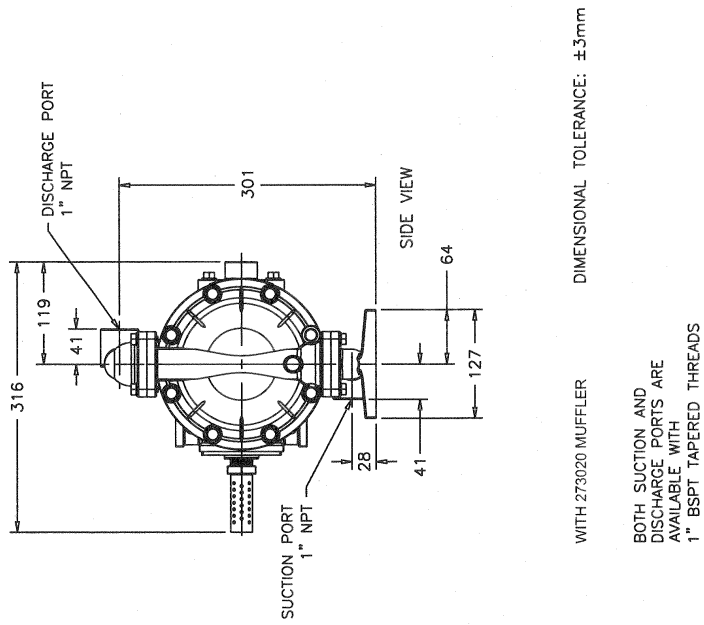

WITH 273020 MUFFLER

BOTH SUCTION AND DISCHARGE PORTS ARE AVAILABLE WITH 1" BSPT TAPERED THREADS

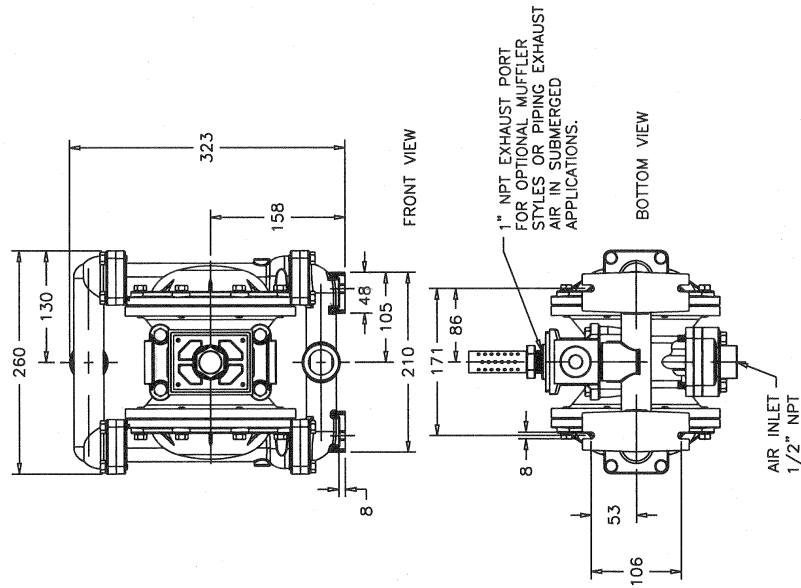

PRINCIPLE OF PUMP OPERATION

This ball type check valve pump is powered by compressed air and is a 1:1 ratio design. The inner side of one diaphragm chamber is alternately pressurized while simultaneously exhausting the other inner chamber. This causes the diaphragms, which are connected by a common rod secured by plates to the centers of the diaphragms, to move in a reciprocating action. (As one diaphragm performs the discharge stroke the other diaphragm is pulled to perform the suction stroke in the opposite chamber.) Air pressure is applied over the entire inner surface of the diaphragm while liquid is discharged from the opposite side of the diaphragm. The diaphragm operates in a balanced condition during the discharge stroke which allows the pump to be operated at discharge heads over 200 feet (61 meters) of water.

For maximum diaphragm life, keep the pump as close to the liquid being pumped as possible. Positive suction head in excess of 10 feet of liquid (3.048 meters) may require a back pressure regulating device to maximize diaphragm life.

Alternate pressurizing and exhausting of the diaphragm chamber is performed by an externally mounted, pilot operated, four way spool type air distribution valve. When the spool shifts to one end of the valve body, inlet pressure is applied to one diaphragm chamber and the other diaphragm chamber exhausts. When the spool shifts to the opposite end of the valve

body, the pressure to the chambers is reversed. The air distribution valve spool is moved by an internal pilot valve which alternately pressurizes one end of the air distribution valve spool while exhausting the other end. The pilot valve is shifted at each end of the diaphragm stroke when an actuator plunger is contacted by the diaphragm plate. This actuator plunger then pushes the end of the pilot valve spool into position to activate the air distribution valve.

The chambers are connected with manifolds with a suction and discharge check valve for each chamber, maintaining flow in one direction through the pump.

INSTALLATION AND START-UP

Locate the pump as close to the product being pumped as possible. Keep the suction line length and number of fittings to a minimum. Do not reduce the suction line diameter.

For installations of rigid piping, short sections of flexible conductive hose should be installed between the pump and the piping. The flexible conductive hose reduces vibration and strain to the pumping system. A surge suppressor is recommended to further reduce pulsation in flow.

AIR SUPPLY

Air supply pressure cannot exceed 125 psi (8.6 bar). Connect the pump air inlet to an air supply of sufficient capacity and pressure required for desired performance. When the air supply line is solid piping, use a short length of flexible conductive hose not less than 1/2"

(13mm) in diameter between the pump and the piping to reduce strain to the piping. The weight of the air supply line, regulators and filters must be supported by some means other than the air inlet cap. Failure to provide support for the piping may result in damage to the pump. A pressure regulating valve should be installed to insure air supply pressure does not exceed recommended limits.

AIR VALVE LUBRICATION

The air distribution valve and the pilot valve are designed to operate WITHOUT lubrication. This is the preferred mode of operation. There may be instances of personal preference or poor quality air supplies when lubrication of the compressed air supply is required. The pump air system will operate with properly lubricated compressed air supply. Proper lubrication requires the use of an air line lubricator set to deliver one drop of SAE 10 non-detergent oil for every 20 SCFM (9.4 liters/sec.) of air the pump consumes at the point of operation. Consult the pump's published Performance Curve to determine this.

AIR LINE MOISTURE

Water in the compressed air supply can create problems such as icing or freezing of the exhaust air, causing the pump to cycle erratically or stop operating. Water in the air supply can be reduced by using a point-of-use air dryer to supplement the user's air drying equipment. This device removes water from the compressed air supply and alleviates the icing or freezing problems.

AIR INLET AND PRIMING

To start the pump, open the air valve approximately 1/2" to 3/4" turn. After the pump primes, the air valve can be opened to increase air flow as desired. If opening the valve increases cycling rate, but does not increase the rate of flow, cavitation has occurred. The valve should be closed slightly to obtain the most efficient air flow to pump flow ratio.

BETWEEN USES

When the pump is used for materials that tend to settle out or solidify when not in motion, the pump should be flushed after each use to prevent damage. (Product remaining in the pump between uses could dry out or settle out. This could cause problems with the diaphragms and check valves at restart.) In freezing temperatures the pump must be completely drained between uses in all cases.

INSTALLATION GUIDE

Top Discharge Ball Valve Pump

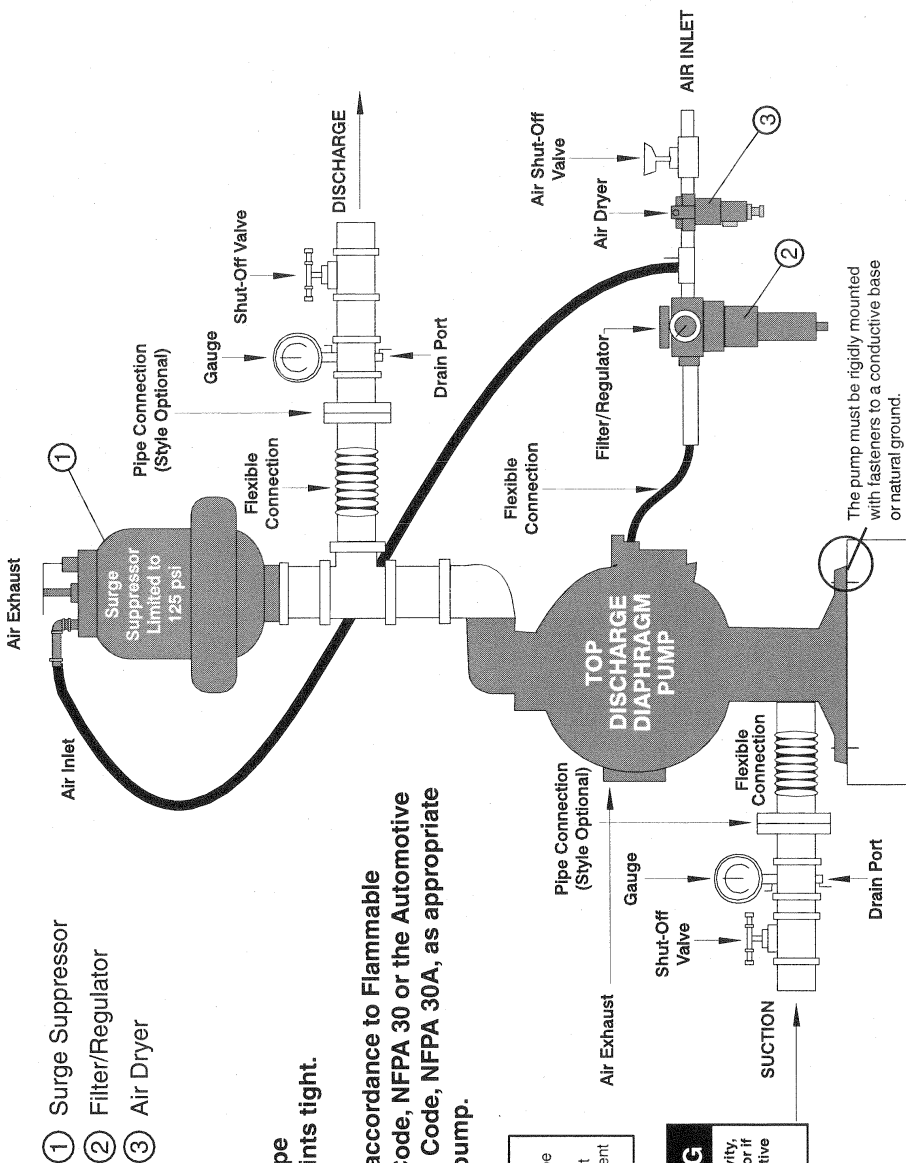

- ① Surge Suppressor
- ② Filter/Regulator
- ③ Air Dryer

⚠ CAUTION

Use a gasoline-resistant pipe compound to make pipe joints tight.

Pump shall be installed in accordance to Flammable and Combustible Liquids Code, NFPA 30 or the Automotive and Marine Service Station Code, NFPA 30A, as appropriate to the intended use of the pump.



⚠ CAUTION
The air exhaust should be piped to an area for safe disposition of the product being pumped, in the event of a diaphragm failure.



⚠ WARNING
To maintain conductivity, do not paint the pump, or if painted, use a conductive paint or coating.

TROUBLESHOOTING

Possible Symptoms:

- Pump will not cycle.
- Pump cycles, but produces no flow.
- Pump cycles, but flow rate is unsatisfactory.
- Pump cycle seems unbalanced.
- Pump cycle seems to produce excessive vibration.

What to Check: Excessive suction lift in system.

Corrective Action: For lifts exceeding 20 feet (6 meters), filling the pumping chambers with liquid will prime the pump in most cases.

What to Check: Excessive flooded suction in system.

Corrective Action: For flooded conditions exceeding 10 feet (3 meters) of liquid, install a back pressure device.

What to Check: System head exceeds air supply pressure.

Corrective Action: Increase the inlet air pressure to the pump. Most diaphragm pumps are designed for 1:1 pressure ratio at zero flow.

What to Check: Air supply pressure or volume exceeds system head.

Corrective Action: Decrease inlet air pressure and volume to the pump as calculated on the published PERFORMANCE CURVE. Pump is cavitating the fluid by fast cycling.

What to Check: Undersized suction line.

Corrective Action: Meet or exceed pump connection recommendations shown on the DIMENSIONAL DRAWING.

What to Check: Restricted or undersized air line.

Corrective Action: Install a larger air line and connection. Refer to air inlet recommendations shown in your pump's SERVICE MANUAL.

What to Check: Check ESADS, the Externally Serviceable Air Distribution System of the pump.

Corrective Action: Disassemble and inspect the main air distribution valve, pilot valve and pilot valve actuators. Refer to the parts drawing and air valve section of the SERVICE MANUAL. Check for clogged discharge or closed valve before reassembly.

What to Check: Rigid pipe connections to pump.

Corrective Action: Install flexible connectors and a surge suppressor.

What to Check: Blocked air exhaust muffler.

Corrective Action: Remove muffler screen, clean or de-ice and reinstall. Refer to the Air Exhaust section of your pump SERVICE MANUAL.

What to Check: Pumped fluid in air exhaust muffler.

Corrective Action: Disassemble pump chambers. Inspect for diaphragm rupture or loose diaphragm plate assembly. Refer to the Diaphragm Replacement section of your pump SERVICE MANUAL.

What to Check: Suction side air leakage or air in product.

Corrective Action: Visually inspect all suction side gaskets and pipe connections.

What to Check: Obstructed check valve.

Corrective Action: Disassemble the wet end of the pump and manually dislodge obstruction in the check valve pocket. Refer to the Check Valve section of the pump SERVICE MANUAL for disassembly instructions.

What to Check: Worn or misaligned check valve or check valve seat.

Corrective Action: Inspect check valves and seats for wear and proper seating. Replace if necessary. Refer to Check Valve section of the pump SERVICE MANUAL for disassembly instructions.

What to Check: Blocked suction line.

Corrective Action: Remove or flush obstruction. Check and clear all suction screens and strainers.

What to Check: Blocked discharge line.

Corrective Action: Check for obstruction or closed discharge line valves.

What to Check: Blocked pumping chamber.

Corrective Action: Disassemble and inspect the wetted chambers of the pump. Remove or flush any obstructions. Refer to the pump SERVICE MANUAL for disassembly instructions.

What to Check: Entrained air or vapor lock in one or both pumping chambers.

Corrective Action: Purge chambers through tapped chamber vent plugs. PURGING THE CHAMBERS OF AIR CAN BE DANGEROUS! Contact the Technical Services Department before performing this procedure. Any model with top-ported discharge will reduce or eliminate problems with entrained air.

If your pump continues to perform below your expectations, contact your local Distributor or factory Technical Services Group for a service evaluation.

WARRANTY

Refer to the enclosed Warranty Certificate.

RECYCLING

Many components of LINCOLN® Metallic AODD pumps are made of recyclable materials (see chart on page 10 for material specifications). We encourage pump users to recycle worn out parts and pumps whenever possible, after any hazardous pumped fluids are thoroughly flushed.

Pump complies with EN809 Pumping Directive and Directive 98/37/EC Safety of Machinery, and ATEX 100a Directive 94/9/EC Equipment for use in potentially Explosive Environments. For reference to the directive certificates visit: www.warrenrupp.com. The technical files stored at KEMA, notified body 0344, under document #203040000.

Underwriters Laboratories, Inc., an Internationally recognized independent organization for testing products to ensure public safety.



IMPORTANT SAFETY INFORMATION



IMPORTANT
Read these safety warnings and instructions in this manual completely, before installation and start-up of the pump. It is the responsibility of the purchaser to retain this manual for reference. Failure to comply with the recommendations stated in this manual will damage the pump, and void factory warranty.



WARNING
Take action to prevent static sparking. Fire or explosion can result, especially when handling flammable liquids. The pump, piping, valves, containers or other miscellaneous equipment must be grounded. (See page 21)



WARNING
This pump is pressurized internally with air pressure during operation. Always make certain that all bolting is in good condition and that all of the correct bolting is reinstalled during assembly.



WARNING
When used for toxic or aggressive fluids, the pump should always be flushed clean prior to disassembly.



WARNING
Before doing any maintenance on the pump, be certain all pressure is completely vented from the pump, suction, discharge, piping, and all other openings and connections. Be certain the air supply is locked out or made non-operational, so that it cannot be started while work is being done on the pump. Be certain that approved eye protection and protective clothing are worn all times in the vicinity of the pump. Failure to follow these recommendations may result in serious injury or death.



WARNING
Airborne particles and loud noise hazards. Wear ear and eye protection.



CAUTION
Before pump operation, inspect all gasketed fasteners for looseness caused by gasket creep. Re-torque loose fasteners to prevent leakage. Follow recommended torques stated in this manual.



WARNING
Before maintenance or repair, shut off the compressed air line, bleed the pressure, and disconnect the air line from the pump. The discharge line may be pressurized and must be bled of its pressure.



WARNING
In the event of diaphragm rupture, pumped material may enter the air end of the pump, and be discharged into the atmosphere. If pumping a product which is hazardous or toxic, the air exhaust must be piped to an appropriate area for safe disposition.



WARNING
Do not smoke near the pump or use the pump near an open flame. Fire or explosion could result.



WARNING
Do not use this pump with portable water or fluids for human consumption.

Composite Repair Parts Drawing

Add Kits:
274577

AIR END KIT (Available Service Kits:)
Air End Kit

Seals, O-Rings, Gaskets, Retaining Rings, Air Valve Assembly and Pilot Valve Assembly

274578

Wetted End Kit
Buna Diaphragms, Buna Check Balls and PTFE Check Valve Seats

274579

Wetted End Kit
Neoprene Backup Diaphragms, PTFE Overlay Diaphragms, PTFE Check Balls and PTFE Check Valve Seat

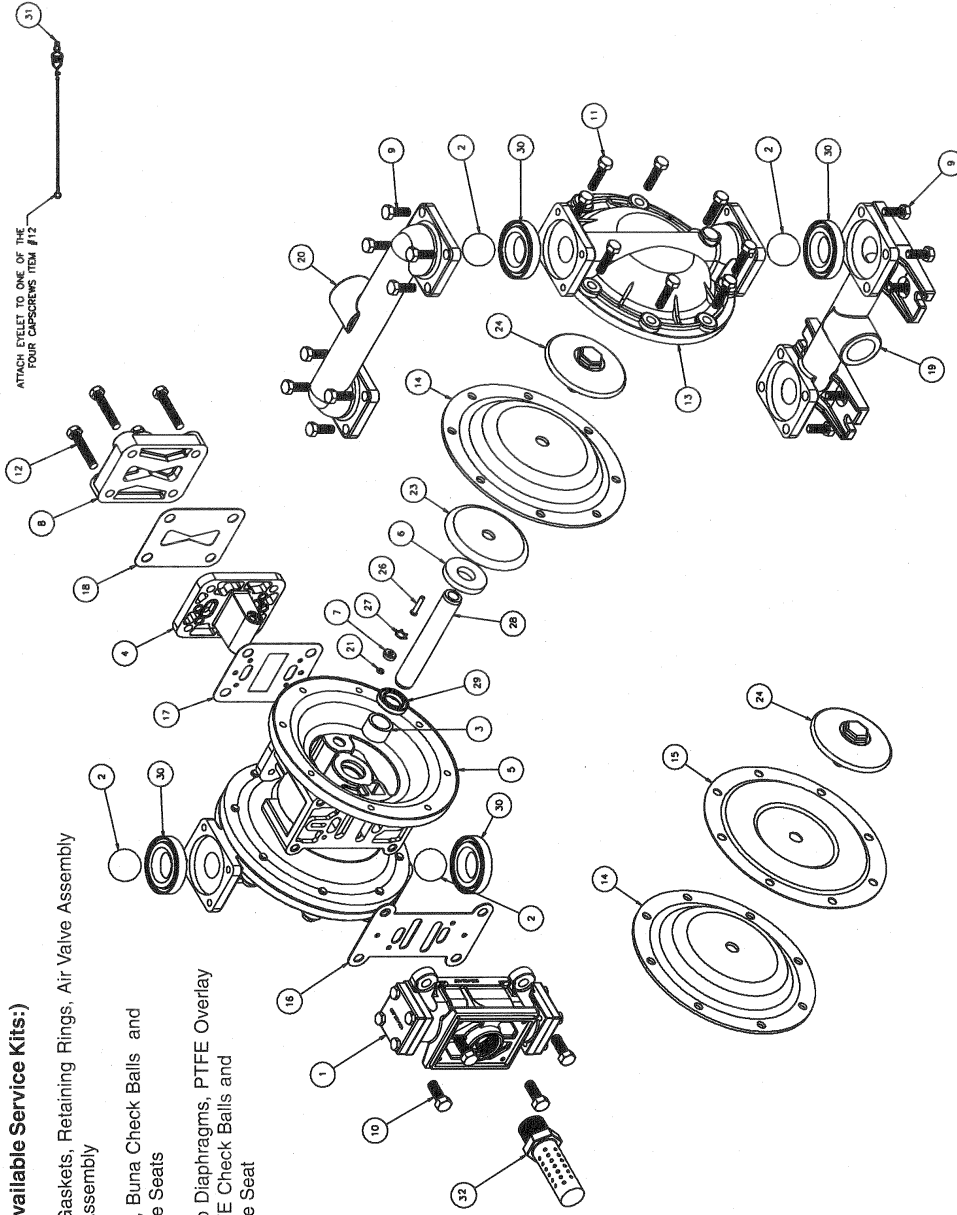

Composite Repair Parts List

ITEM	PART NUMBER	DESCRIPTION	QTY	ITEM	PART NUMBER	DESCRIPTION	QTY
1	274565	Air Valve Assembly	1	15	240749	Diaphragm, PTFE Overlay	2
2	274566	Ball, Buna N Check	4	16	271795	Gasket, Air Valve	1
3	271815	Ball, PTFE Check	4	17	271796	Gasket, Pilot Valve	1
4	240720	Bushing	2	18	273018	Gasket, Air Inlet	1
5	274567	Pilot Valve Assembly	1	19	271823	Manifold, Suction	1
6	274568	Intermediate	1	20	274571	Manifold, Discharge	1
7	240727	Bumper	2	21	274572	O-Ring	2
8	252901	Bushing	2	23	240729	Plate, Inner Diaphragm	2
9	271818	Cap, Air Inlet Assembly	1	24	240728	Plate, Outer Diaphragm Assembly	2
10	271819	Cap, Hex Hd 5/16-18 X .88	16	26	271825	Pin, Actuator	2
11	273015	Cap, Hex Hd 3/8-16 X 1.00	4	27	240717	Ring, Retaining	2
12	240731	Cap, Hex Hd 5/16-18 X 1.25	16	28	271826	Rod, Diaphragm	1
13	271820	Cap, Hex Hd 5/16-18 X 1.75	4	29	240721	Seat, U-Cup	2
14	274569	Chamber, Outer	2	30	274573	Seat, Check Ball	4
	274570	Diaphragm, Buna N	2	31	274574	Ground Strap	1
	240873	Diaphragm, Neoprene	2	32	273020	Metal Muffler	1

Air Valve Assembly Drawing, Parts List

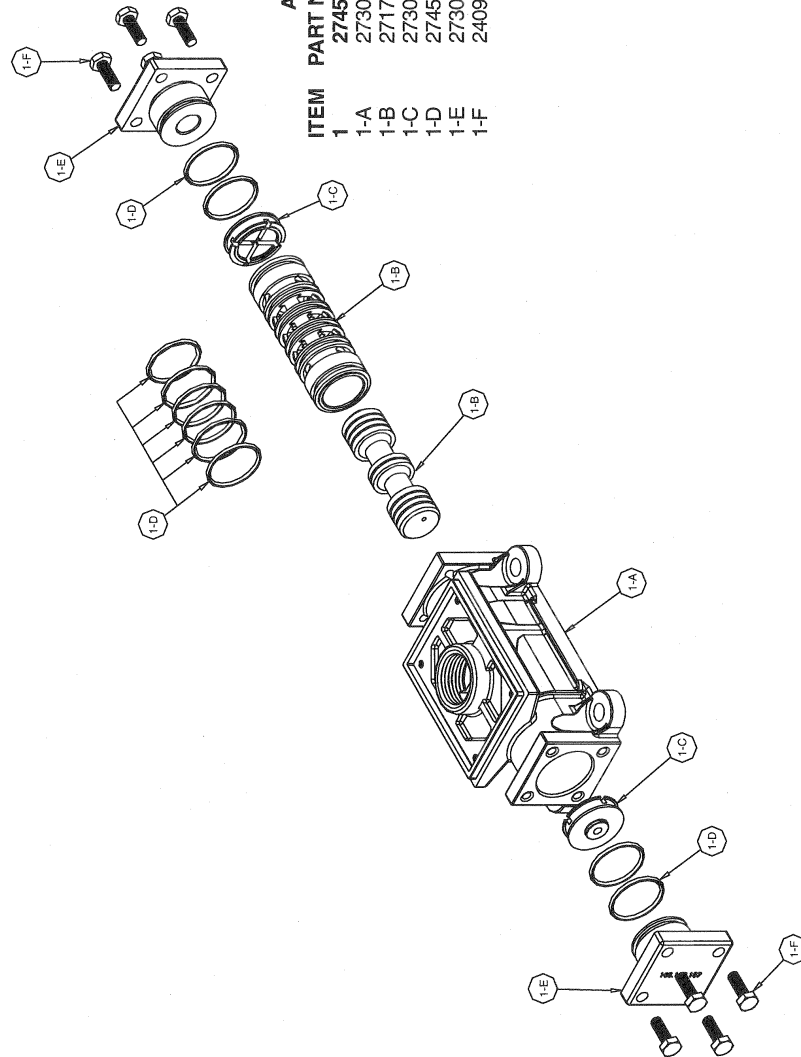

ITEM	PART NUMBER	DESCRIPTION	QTY
1	274575	Gas Valve Assembly	1
1-A	273041	Valve Body	1
1-B	271774	Sleeve and Spool Set	1
1-C	273042	Bumper	2
1-D	274576	O-Ring	10
1-E	273043	Cap End	2
1-F	240934	Capscrew	8

AIR DISTRIBUTION VALVE SERVICING

To service the air valve first shut off the compressed air, bleed pressure from the pump, and disconnect the air supply line from the pump.

STEP #1: See COMPOSITE REPAIR PARTS DRAWING.

Using a 9/16" wrench or socket, remove the four hex head cap screws (item 10). Remove the air valve assembly from the pump.

Remove and inspect gasket (item 16) for cracks or damage. Replace gasket if needed.

STEP #2: Disassembly of the air valve.

Using a 7/16" wrench or socket, remove the eight hex cap screws (item 1-F) that fasten the end caps to the valve body.

Next remove the two end caps (items 1-E). Inspect two o-rings (items 1-D) on each end cap for damage or wear. Replace the o-rings as needed.

Remove the bumpers (items 1-C). Inspect the bumpers for damage or wear.

Remove the spool (part of item 1-A) from the sleeve. Be careful not to scratch or damage the outer diameter of the spool. Wipe spool with a soft cloth and inspect for scratches or wear.

Inspect the inner diameter of the sleeve (part of item 1-A) for dirt, scratches, or other contaminants. Remove the sleeve if needed and replace with a new sleeve and spool set (item 1-A).

STEP #3: Reassembly of the air valve.

Install one bumper (item 1-C) and one end cap (item 1-E) with two o-rings (item 1-D) and fasten with four hex cap screws (items 1-F) to the valve body (items 1-A).

Remove the new sleeve and spool set (item 1-A) from the plastic bag. Carefully remove the spool from the sleeve. Install the six o-rings (item 1-G) into the six grooves on the sleeve. Apply a light coating of grease to the o-rings before installing the sleeve into the valve body (item 1-B), align the slots in the sleeve with the slots in the valve body. Insert the spool into the sleeve. Be careful not to scratch or damage the spool during installation. Push the spool in until it touches the bumper on the opposite end. Install the remaining bumper, end cap (with o-rings), and fasten with the remaining hex cap screws.

Fasten the air valve assembly (item 1) and gasket (item 16) to the pump.

Connect the compressed air line to the pump. The pump is now ready for operation.



IMPORTANT

Read these instructions completely, before installation and start-up. It is the responsibility of the purchaser to retain this manual for reference. Failure to comply with the recommendations stated in this manual will damage the pump, and void factory warranty.

Pilot Valve Servicing, Assembly Drawing & Parts List

PILOT VALVE ASSEMBLY PARTS LIST

ITEM	PART NUMBER	DESCRIPTION	QTY
4	274583	Pilot Valve Assembly	1
4-A	274584	Valve Body	1
4-B	274585	Sleeve (With O-rings)	1
4-C	274586	O-ring (Sleeve)	6
4-D	274587	Spool (With O-rings)	1
4-E	274588	O-ring (Spool)	3
4-F	274589	Retaining Ring	1

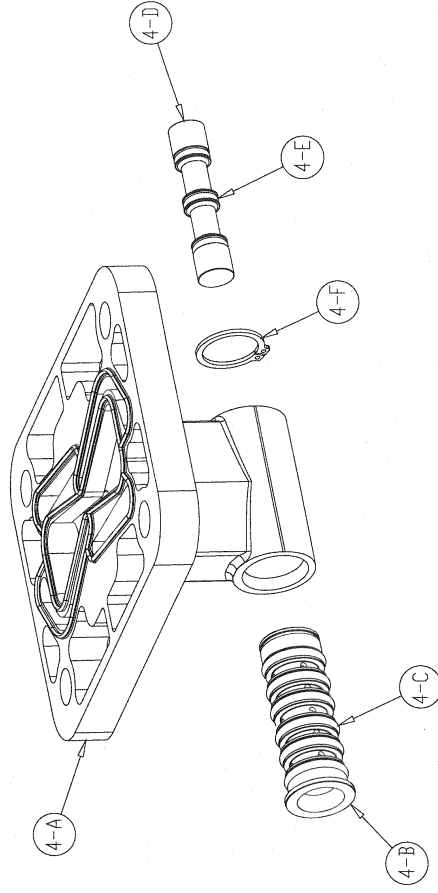

PILOT VALVE SERVICING

To service the pilot valve first shut off the compressed air supply, bleed the pressure from the pump, and disconnect the air supply line from the pump.

STEP #1: See pump assembly drawing.

Using a 1/2" wrench or socket, remove the four capscrews (item 12). Remove the air inlet cap (item 8) and air inlet gasket (item 18). The pilot valve assembly (item 4) can now be removed for inspection and service.

STEP #2: Disassembly of the pilot valve.

Remove the pilot valve spool (item 4-D). Wipe clean and inspect spool and o-rings for dirt, cuts or wear. Replace the o-rings and spool if necessary.

Remove the retaining ring (item 4-F) from the end of the sleeve (item 4-B) and remove the sleeve from the valve body (item 4-A). Wipe clean and inspect sleeve and o-rings for dirt, cuts or wear. Replace the o-rings and sleeve if necessary.

STEP #3: Re-assembly of the pilot valve.

Generously lubricate outside diameter of the sleeve and o-rings. Then carefully insert sleeve into valve body. Take CAUTION when inserting sleeve, not to shear any o-rings. Install retaining ring to sleeve. Generously lubricate outside diameter of spool and o-rings. Then carefully insert spool into sleeve. Take CAUTION when inserting spool, not to shear any o-rings. Use BP-LS-EP-2 multipurpose grease, or equivalent.

STEP #4: Re-install the pilot valve assembly into the intermediate.

Be careful to align the ends of the pilot valve stem between the plunger pins when inserting the pilot valve into the cavity of the intermediate.

Re-install the gasket, air inlet cap and capscrews. Connect the air supply to the pump. The pump is now ready for operation.

**Diaphragm Service Drawing,
Non-Overlay**

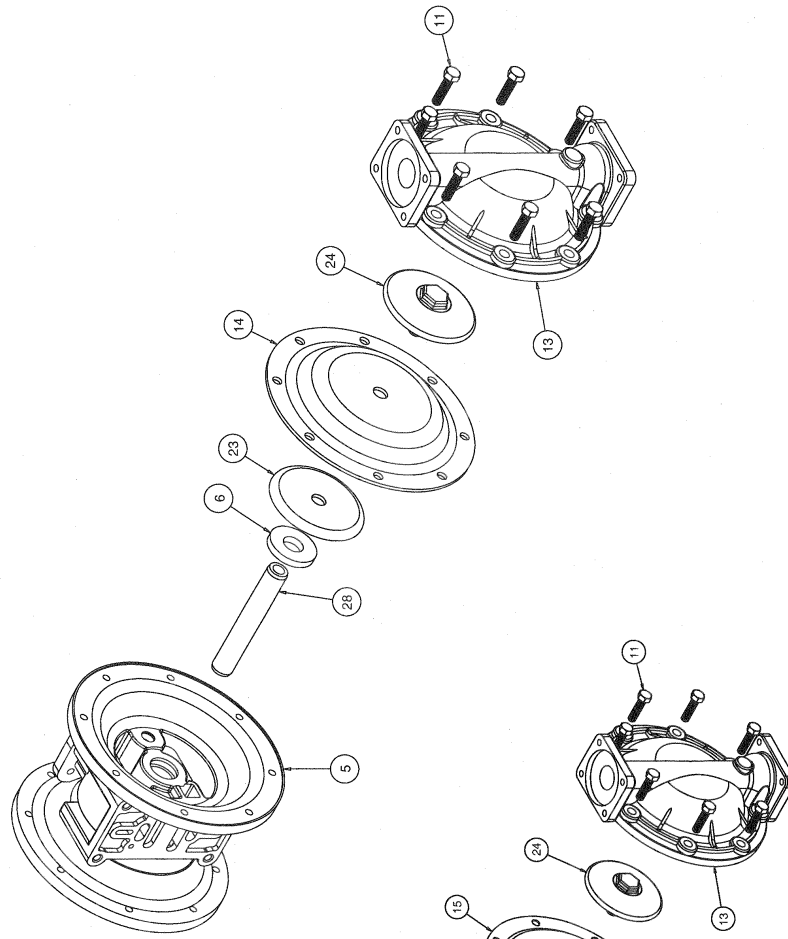

**Diaphragm Service Drawing,
with Overlay**

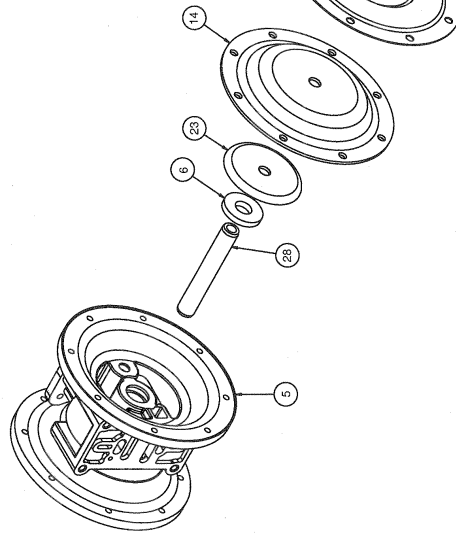

DIAPHRAGM SERVICING

To service the diaphragms first shut off the suction, then shut off the discharge lines to the pump. Shut off the compressed air supply, bleed the pressure from the pump and disconnect the air supply line from the pump. Drain any remaining liquid from the pump.

Step #1: See the pump assembly drawing and the diaphragm servicing illustration.

Using a 1/2" wrench or socket, remove the 16 capscrews (item 9) that fasten the manifolds (items 19 & 20) to the outer chambers (item 13).

Step #2: Removing outer chambers.

Using a 1/2" wrench or socket, remove the 16 capscrews (item 11), that fasten the outer chambers (item 13), diaphragms (item 14) and intermediate (item 5) together.

Step #3: Removing the diaphragms and diaphragm plates.

Use a 7/8" wrench or six point socket to remove the outer diaphragm plate assemblies (item 24), diaphragms (item 14) and inner diaphragm plates (item 23) from the diaphragm rod (item 28) by turning counterclockwise. Inspect the diaphragm for cuts, punctures, abrasive wear or chemical attack. Replace the diaphragms if necessary. **DO NOT USE A WRENCH ON THE DIAPHRAGM ROD. FLAWS ON THE SURFACE MAY DAMAGE BEARINGS AND SEALS.**

Step #4: Assembling the diaphragm and diaphragm plates to the diaphragm rod.

Push the threaded stud of one outer diaphragm plate assembly through the center of one diaphragm and through one inner diaphragm plate. Install the diaphragm with the natural bulge facing away from the diaphragm rod and make sure the radius on the inner diaphragm plate is towards the diaphragm, as indicated on the diaphragm servicing illustration. Thread the assembly onto the diaphragm rod, leaving loose.

Step #5: Installing the diaphragm and rod assembly to the pump.

Make sure the bumper (item 6) is installed over the diaphragm rod. Insert rod into pump.

On the opposite side of the pump, pull the diaphragm rod out as far as possible. Make sure the second bumper is installed over the diaphragm rod.

Push the threaded stud of the other outer diaphragm plate assembly through the center of the other diaphragm and through the other inner diaphragm plate. Make sure the radius on the inner diaphragm plate is towards the diaphragm. Thread the assembly onto the diaphragm rod. Use a 7/8" wrench or socket to hold one outer diaphragm plate. Then, use a torque wrench to tighten the other outer diaphragm plate to the diaphragm rod to 350 in. lbs. (39.5 Newton meters).

Align one diaphragm with the intermediate and install the outer chamber to the pump using the 8

capscrews. Tighten the opposite diaphragm plate until the holes in the diaphragm align with the holes in the intermediate. Then, install the other outer chamber using the 8 capscrews.

Step #6: Reinstall the manifolds to the pump using the 16 capscrews.

The pump is now ready to be reinstalled, connected and returned to operation.

OVERLAY DIAPHRAGM SERVICING

The overlay diaphragm (item 15) is designed to fit over the exterior of the standard diaphragm (item 14).

Follow the same procedures described for the standard diaphragm for removal and installation, except tighten the outer diaphragm plate assembly, diaphragms and inner diaphragm plate to the diaphragm rod to 350 in. lbs. (39.5 Newton meters).



▲ IMPORTANT
 Read these instructions completely, before installation and start-up. It is the responsibility of the purchaser to retain this manual for reference. Failure to comply with the recommendations stated in this manual will damage the pump, and void factory warranty.

ACTUATOR PLUNGER SERVICING

To service the actuator plunger first shut off the compressed air supply, bleed the pressure from the pump, and disconnect the air supply line from the pump.

Step #1: See PUMP ASSEMBLY DRAWING.

Using a 1/2" wrench or socket, remove the four capscrews (items 11). Remove the air inlet cap (item 8) and air inlet gasket (item 18). The pilot valve assembly (item 4) can now be removed.

Step #2: Inspect the actuator plungers.

See ILLUSTRATION AT RIGHT.

The actuator plungers (items 25) can be reached through the pilot valve cavity in the intermediate assembly (item 5).

Remove the plungers (item 25) from the bushings (item 7) in each end of the cavity. Inspect the installed o-ring (items 21) for cuts and/or wear. Replace the o-rings if necessary. Apply a light coating of grease to each o-ring and re-install the plungers in to the bushings. Push the plungers in as far as they will go.

To remove the bushings (item 7), first remove the retaining rings (item 26) by using a flat screwdriver.

NOTE: It is recommended that new retaining rings be installed.

Step #3: Re-install the pilot valve assembly into the intermediate assembly.

Be careful to align the ends of the stem between the plungers when inserting the stem of the pilot valve into the cavity of the intermediate.

Re-install the gasket (item 18), air inlet cap (item 8) and capscrews (item 11).

Connect the air supply to the pump. The pump is now ready for operation.

ACTUATOR PLUNGER SERVICING

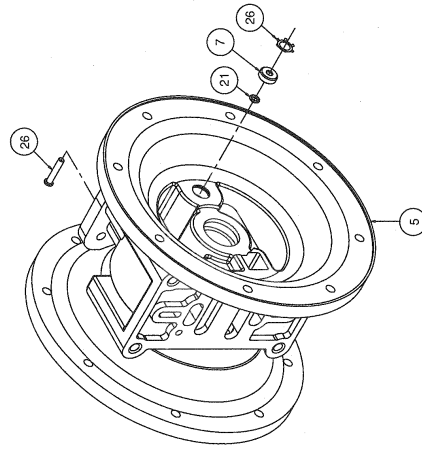

IMPORTANT



Read these instructions completely, before installation and start-up. It is the responsibility of the purchaser to retain this manual for reference. Failure to comply with the recommendations stated in this manual will damage the pump, and void factory warranty.

Check Valve Drawing

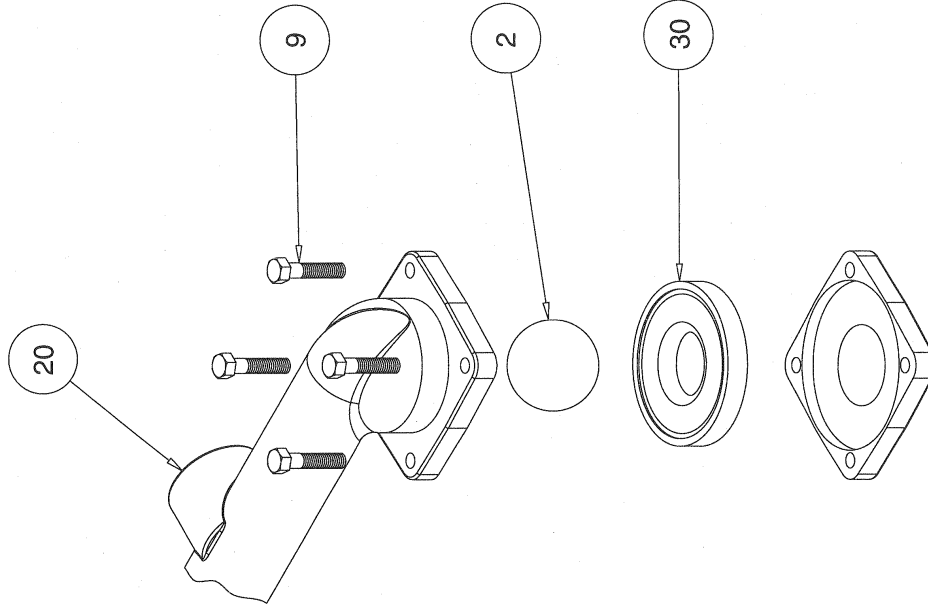

CHECK VALVE SERVICING

Before servicing the check valve components, first shut off the suction line and then the discharge line to the pump. Next, shut off the compressed air supply, bleed air pressure from the pump, and disconnect the air supply line from the pump. Drain any remaining fluid from the pump. The pump can now be removed for service.

To access the check valve components, remove the manifold (item 20 or item 19 not shown). Use a 1/2" wrench or socket to remove the fasteners. Once the manifold is removed, the check valve components can be seen.

Inspect the check balls (items 2) for wear, abrasion, or cuts on the spherical surface. The check valve seats (item 30) should be inspected for cuts, abrasive wear, or embedded material on the surfaces of both the external and internal chambers. The spherical surface of the check balls must seat flush to the surface of the check valve seats for the pump to operate to peak efficiency. Replace any worn or damaged parts as necessary.

Re-assemble the check valve components. The seat should fit into the counter bore of the outer chamber.

The pump can now be reassembled, reconnected and returned to operation.

PUMPING HAZARDOUS LIQUIDS

When a diaphragm fails, the pumped liquid or fumes enter the air end of the pump. Fumes are exhausted into the surrounding environment. When pumping hazardous or toxic materials, the exhaust air must be piped to an appropriate area for safe disposal. See illustration #1 at right.

This pump can be submerged if the pump materials of construction are compatible with the liquid being pumped. The air exhaust must be piped above the liquid level. See illustration #2 at right. Piping used for the air exhaust must not be smaller than 1" (2.54 cm) diameter. Reducing the pipe size will restrict air flow and reduce pump performance. When the pumped product source is at a higher level than the pump (flooded suction condition), pipe the exhaust higher than the product source to prevent siphoning spills. See illustration #3 at right.

CONVERTING THE PUMP FOR PIPING THE EXHAUST AIR

The following steps are necessary to convert the pump to pipe the exhaust air away from the pump.

Remove the muffler (item 32). The air distribution valve (item 1) has 1" NPT threads for piped exhaust.

IMPORTANT INSTALLATION

NOTE: The manufacturer recommends installing a flexible conductive hose or connection between the pump and any rigid plumbing. This reduces stresses on the molded threads of the air exhaust port. Failure to do so may result in damage to the air distribution valve body.

Any piping or hose connected to the pump's air exhaust port must be conductive and physically supported. Failure to support these connections could also result in damage to the air distribution valve body.

Air Valve Assembly

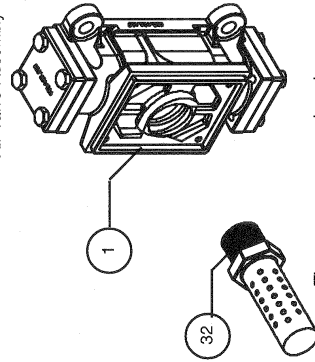

CONVERTED EXHAUST ILLUSTRATION

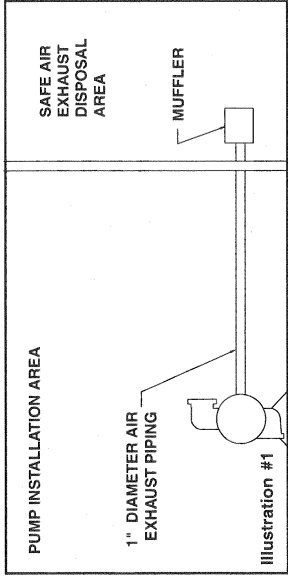

Illustration #1

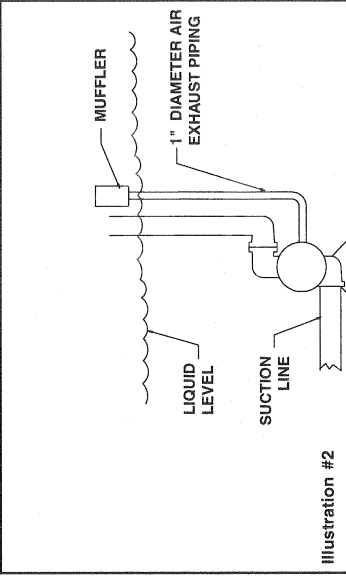

Illustration #2

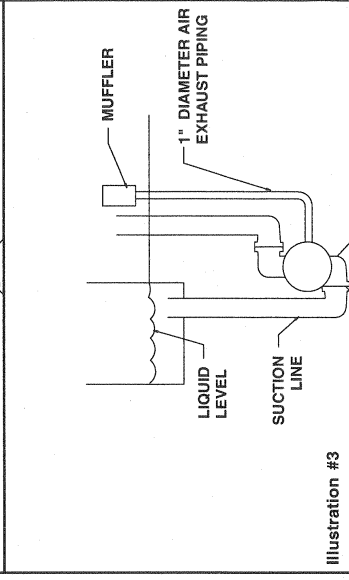
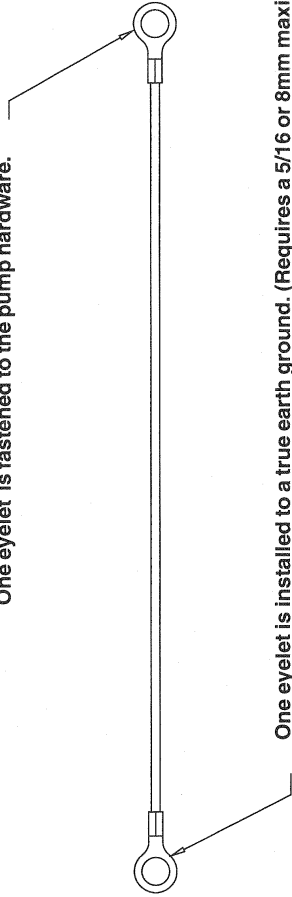

Illustration #3

Grounding The Pump

One eyelet is fastened to the pump hardware.



One eyelet is installed to a true earth ground. (Requires a 5/16 or 8mm maximum diameter bolt)

This 8 foot long (244 centimeters) Ground Strap (Item 31) is shipped with the eyelet end fastened to the pump hardware.

To reduce the risk of static electrical sparking, this pump must be grounded. Check the local electrical code for detailed grounding instruction and the type of equipment required, or in the absence of local codes, an industry or nationally recognized code having jurisdiction over specific installations, and/or CAN/CGA B149, installation codes.

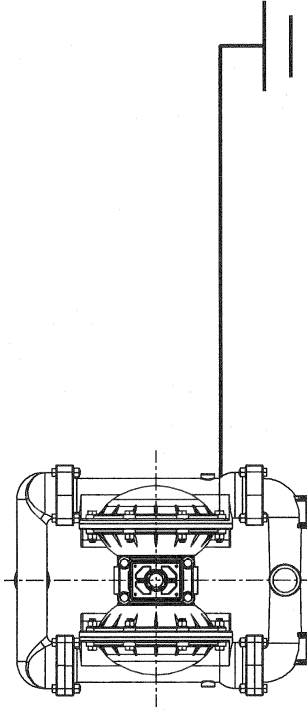

	WARNING
<i>Take action to prevent static sparking. Fire or explosion can result, especially when handling flammable liquids. The pump, piping, valves, containers or other miscellaneous equipment must be grounded.</i>	



APPENDIX II

Static Discharge Grounding Reel Installation/Operation Instructions

**STATIC DISCHARGE GROUNDING REEL
INSTALLATION / OPERATION INSTRUCTION SHEET
P/N 922-30-028**

Introduction

Static Discharge Reels; 200-20R, 700-50R and ML2930 & ML3416 Series to be used for bonding and grounding on mobile fuel equipment at bulk stations, airports, terminals, refineries, et cetera.

Bonding and Grounding Principles

Bonding connects various pieces of conductive equipment together to keep them at the same potential. Static sparking can not occur between objects that are at the same potential.

Grounding is a form of bonding in which conductive equipment is connected to an earthing electrode or to a building grounding system in order to prevent sparking between conductive equipment and grounding structures.

Refer to the National Fire Protection Association Codes, NFPA 77 and NFPA 99 for recommended practice on static electricity.

Reel Installation

Mount Grounding Reel to object or vehicle with bolts using holes provided in base. Underside of bracket is unpainted providing a conductive surface to interface with a clean conductive surface on the object or vehicle. After mounting reel check electrical continuity (25 ohms. max.) between object or vehicle and grounding clamps at the end of the cable.

Reel Operation

Extend cable to desired object or earthing ground lug and clamp alligator jaw grip or other grounding connector in place. A pawl and ratchet permits locking of cable at any desired length within the reel's capacity. A simple tug on the cable unlocks the reel for a smooth and steady walk-back retraction.

Perform periodic tests of the bonded object to the ground clamp on the end of the cable grounding reel with Ohm Meter to confirm continuity. Maximum resistance to be 25 ohms. If higher, remove and replace reel. Inspect the entire cable length for kinks and/or broken wires. Inspect the cable clamp for good compression force and/or damage.

Caution: Do not use any part of the electrical current carrying system as a ground for static grounding. Arcing and fires could occur from current feedback where static control grounds are tied into the electrical system neutral.

WARNING:

This product can aid in the discharge of static electricity. No prediction or advice, however, can be given about all the different conditions which can cause static discharges to accumulate. Moreover, it can not be guaranteed that the use of this product (without other precautionary steps) will prevent static ignited fires or explosions which may result in serious injury or death.

SEEK PROFESSIONAL ADVICE BEFORE INSTALLING AND / OR USING THIS PRODUCT.



APPENDIX III

Differential Pressure Gauge

H-2944
Rev OR

EC 1512
08/2006



VF-61 Differential Pressure Gauge Assembly Part Number 10678



Differential Pressure Gauge Kit for use with the VF-61 Housing

This unit measures pressure difference between two points. The gauge allows for a simple reading on an easy-to-read scale. A red/green dial with a breakpoint located at 15 psid alerts the user of the condition of the process.

This kit consists of the following components:

- Differential Pressure Gauge: aluminum body, 1/8" NPT bottom, 1" molded lens & 0-20 psid scale,
- Compression Fittings: 1 straight, 1 90° elbow
- 1/4 O.D. Copper Tubing

Operation

When the needle is in the green zone of the gauge during normal flow, the differential pressure is less than 15 psid across the installed element, and the element does not need to be changed out.

When the needle is in the red zone, the differential pressure is more than 15 psid and the element should be changed out. It has reached its recommended maximum pressure differential.

CAUTION:

Do not mount the P/N 10678 differential pressure gauge assembly any closer than 2" from a steel bracket or pipe. The gauge has a magnetic piston, and mounting too close to steel may affect the accuracy.



APPENDIX IV

Fill-Rite 807CN Meter Owner/Operator Manual

