

Columbus**JACK**/Regent



**MODEL 5007-56FT**  
**50 TON FLYAWAY AXLE JACK**  
**P/N: 150D1100-56**

Operation and Maintenance Manual  
with Illustrated Parts List

2222 South Third Street  
Columbus, Ohio 43207-2402  
Phone (614) 443-7492 FAX (614) 445-3981  
[sales@columbusjack.com](mailto:sales@columbusjack.com)

**MODEL 5007-56FT  
50 TON FLYAWAY AXLE JACK  
PAGE -1-**

**1.0 Introduction**

This manual is issued as a basic operation and maintenance manual covering the Model 5007-56FT, 50 Ton Flyaway Axle Jack manufactured by Columbus**JACK**/Regent, 2222 S. Third St., Columbus, Ohio 43207, USA, phone number (614) 443-7492, FAX (614) 445-3981.

To derive maximum service, it is recommended that personnel have an understanding of the equipment before attempting to operate the jack. It is mandatory that the operating procedures herein be followed.

**2.0 Specifications**

Capacity	50 Tons
Minimum Height	7.0 Inches
Hydraulic Lift	12.0 Inches
Screw Extension	3.38 Inches
Maximum Height	22.38 Inches
Operating Pressure	9680 Psi
Relief Valve Pressure	10,650 Psi
Reservoir Capacity	1.0 Gallon
Air Requirements	
Pressure	80 Psi Minimum
Flow	40 Scfm Minimum
Estimated Weight	175 Lbs.

**3.0 Safety Information**

***Make sure all personnel involved with this jack read and understand these instructions before using.***

**WARNING:** The jack is designed to lift only vertical loads with a maximum weight of 50 tons (100,000 pounds). Do not use jack for lifts exceeding the weight or design limits. Failure to comply can result in injury or death to personnel and/or severe damage to the jack and aircraft.

**4.0 Bleed Procedure**

4.1 Using hand pump or air pump, cycle cylinder rams several times.

**MODEL 5007-56FT  
50 TON FLYAWAY AXLE JACK  
PAGE -2-**

**5.0 Pre-Operation Procedure**

- 5.1 Perform visual inspection, by checking for fluid leakage.
- 5.2 Check for loose, damaged or missing parts.
- 5.3 Check oil level.

**6.0 Lifting Procedure**

- 6.1 Verify jack is located per airplane jacking procedures.
- 6.2 Raise extension screw to mate with airplane axle jacking point.
- 6.3 Close release valve.
- 6.4 Connect air supply.
- 6.5 Activate the air pump.

**CAUTION: WITH NO LOAD APPLIED TO THE JACK, IT IS NORMAL FOR ANY STAGE TO EXTEND FIRST. ONCE A LOAD IS APPLIED TO THE JACK, ENSURE THAT THE FIRST STAGE RAM (LARGER) IS FULLY EXTENDED FIRST, BEFORE THE SECOND STAGE RAM (SMALLER) BEGINS TO EXTEND. ENSURE THAT THE SECOND STAGE RAM (SMALLER) IS FULLY EXTENDED BEFORE THE THIRD STAGE RAM (SMALLEST) BEGINS TO EXTEND. IF THE JACK DOES NOT EXTEND IN THIS SEQUENCE, THE JACK SHOULD BE DISASSEMBLED TO DETERMINE THE CAUSE OF THE EXCESSIVE FRICTION IN THE RAM STAGES.**

**7.0 Lowering Procedure**

- 7.1 Slowly open release valve to lower rams.
- 7.2 When airplane tires are on ground, open release valve completely.
- 7.3 Activate the hand valve mounted on reservoir to fully retract rams.
- 7.4 When rams are fully lowered, release the hand valve.
- 7.5 Lower extension screw fully and disconnect the air supply.
- 7.6 Remove jack from under airplane.

**MODEL 5007-56FT  
50 TON FLYAWAY AXLE JACK  
PAGE -3-**

**8.0 Relief Valve Setting**

- 8.1 Position jack under a jack tester. Fully extend the first and second stage rams and partially extend the third stage ram.
- 8.2 Remove pin (Item 19).
- 8.3 Operate air pump and verify that relief valve is set at 52.5 – 55 tons. Increase pressure setting by using a screwdriver to adjust relief valve screw (Item 8) clockwise. To decrease pressure setting, adjust relief valve screw counterclockwise.

**CAUTION: USE CARE NOT TO SET VALVE MORE THAN 10% ABOVE RATED CAPACITY.**

**WARNING: DO NOT EXCEED 55 TONS.**

- 8.4 Reinstall pin (Item 19).

**9.0 Special Maintenance Instructions**

There are no special maintenance instructions for this jack.

**10.0 Shop Aids Available**

Contact Columbus**JACK**/Regent Sales for any shop aids.

**11.0 Overhaul Kits Available**

Soft Kit            120A1643

**12.0 How to Locate and Remedy Trouble**

If operational troubles are encountered, refer to the Trouble Shooting Chart which lists the most commonly occurring problems and gives information which will facilitate location of trouble source and determination of remedial action.

**MODEL 5007-56FT  
50 TON FLYAWAY AXLE JACK  
PAGE -4-**

**TROUBLE SHOOTING CHART**

<b>TROUBLE</b>	<b>PROBABLE CAUSE</b>	<b>REMEDY</b>
Rams fail to lift when operated, or jacks fails to lift rated load.	Incorrect setting of relief valve.	Adjust setscrew clockwise to increase system relief pressure.
	Low fluid level	Fill to correct fluid level.
	Defective outlet check valves.	Remove pump assemblies. Remove and inspect spring and steel ball and replace if necessary.
	Worn plunger o-ring or back-up ring.	Remove cotter pin, pins and fulcrum. Remove and inspect o-rings and backup rings and replace if necessary.
	Defective inlet check valve.	Remove pump assembly. Remove cotter pin, pins, fulcrum, plug and cotter pin. Turn pump base upside-down and remove steel ball. Inspect cotter pin and steel ball and replace if necessary.
	Valve body partially open.	Using slotted pump handle, adjust valve body clockwise until tight.
Pumps inoperative or difficult to operate.	Vacuum created in reservoir due to clogged muffler.	Clean muffler.
	Obstructed pump passage.	Remove pump assemblies. Completely disassemble pumps and blow compressed air into passages to free obstruction.
Pistons will not lower.	Obstructed pump passage.	Remove pump assemblies. Completely disassemble pumps and blow compressed air into passages to free obstruction.
Rams will not fully elevate.	Low fluid level.	Inspect and fill to correct level.
	Defective ram o-rings or back-up rings.	Remove first, second and third stage rams. Remove and inspect o-rings and backup rings and replace if necessary.
	Valve body partially open.	Using slotted pump handle, adjust valve body clockwise until tight.

MODEL 5007-56FT  
 50 TON FLYAWAY AXLE JACK  
 PAGE -5-

TROUBLE SHOOTING CHART

TROUBLE	PROBABLE CAUSE	REMEDY
Rams will not support load.	Oil leaks at rams.	Remove first, second and third stage rams. Remove and inspect o-rings and backup rings and replace if necessary.
	Defective pump assembly o-rings.	Remove pump assemblies. Remove and inspect hand pump piston o-rings and replace if necessary.
	Defective outlet check valve.	Remove and inspect spring and steel ball. Replace if necessary.
	Loose pump assembly.	Tighten socket head screw.
Rams rise and fall with each stroke.	Valve body partially open.	Using slotted pump handle, adjust valve body clockwise until tight.
	Incorrect setting of relief valve.	Adjust setscrew clockwise to increase system relief pressure.
	Defective outlet check valve.	Remove pump assemblies. Remove and inspect spring and steel ball. Replace if necessary.

# ColumbusJACK/Regent

Model 5007-56FT  
 50 Ton Flyaway Axle Jack  
 Page 1 of 6  
 Figure 1

FIG. & ITEM NO.	PART NUMBER	DESCRIPTION	UNITS PER ASSY
<b>1-</b>	<b>5007-56FT</b>	<b>50 Ton Flyaway Axle Jack .....</b>	<b>Ref.</b>
-1	150C1200	Lift Assembly .....	1
-2	875D1800	Reservoir .....	1
-3	566-02	Pump Assembly.....	1
-4	875C1102	Towbar.....	1
-5	469B1211	Pump Handle.....	1
-6	875B1105	Wheel.....	1
-7	875A1103	Axle.....	1
-8	160B609	Plate, Operating Instructions .....	1
-9	SC-284	Vacuum Pump .....	1
-10	450A5960	Muffler.....	1
-11	611-11111	O-Ring .....	1
-12	Not Used		
-13	316-12040	Pan Head Screw, Slotted .....	4
-14	322-03320	Cotter Pin.....	2
-15	345-11032-T	Flat Washer .....	4
-16	346-10016-IT	Lockwasher.....	4
-17	323-14110	Quick Release Pin .....	2
-18	1504-5	Chain Assembly.....	2
-19	450A6994	Drive Screw .....	2
-20	484-00404	Female Pipe Elbow.....	1
-21	456-10602-A	Male Elbow .....	2
-22	Not Used		
-23	466-10606-A	Swivel Nut Elbow.....	1
-24	450A5963	Female Connector .....	1
-25	450A5962	Male Connector .....	1
-26	450A3202	Valve.....	2
-27	485-50604	Pipe Thread Reducer .....	1
-28	485-40606	Male Run Tee .....	1
-29	488-00006	Pipe Plug .....	1
-30	483-00606	Male Pipe Elbow.....	1
-31	SST-13849	Stainless Tube.....	A/R
-32	450A5961	Hose .....	A/R
-33	450A3344	Hydraulic Pump .....	1
-34	450B1814-1	Manifold .....	1
-35	483-10604	Pipe Nipple .....	1
-36	485-00404	Street Elbow .....	2
-37	483-10606	Pipe Nipple .....	1
-38	Not Used		
-39	450A3381	Filter Regulator .....	1
-40	456-10404-A	Male Elbow .....	2
-41	Not Used		
-42	SST-8000	Stainless Tube.....	A/R
-43	377-20120	Socket Head Cap Screw .....	4
-44	488-00002	Pipe Plug .....	1
-45	488-00004	Pipe Plug .....	1

# ColumbusJACK/Regent

Model 5007-56FT  
50 Ton Flyaway Axle Jack  
Page 2 of 6  
Figure 1

FIG. & ITEM NO.	PART NUMBER	DESCRIPTION	UNITS PER ASS'Y
-46	611-11311	O-Ring .....	2
-47	50B7767	Spring .....	1
-48	53A22044	Screen .....	1
-49	372-10060	Hex Head Cap Screw .....	2
-50	346-10010	Lockwasher.....	2
-51	483-10404	Pipe Nipple .....	1
-52	456-10606	Male Elbow .....	1

# ColumbusJACK/Regent

Model 5007-56FT  
50 Ton Flyaway Axle Jack  
Page 3 of 6  
Figure 1

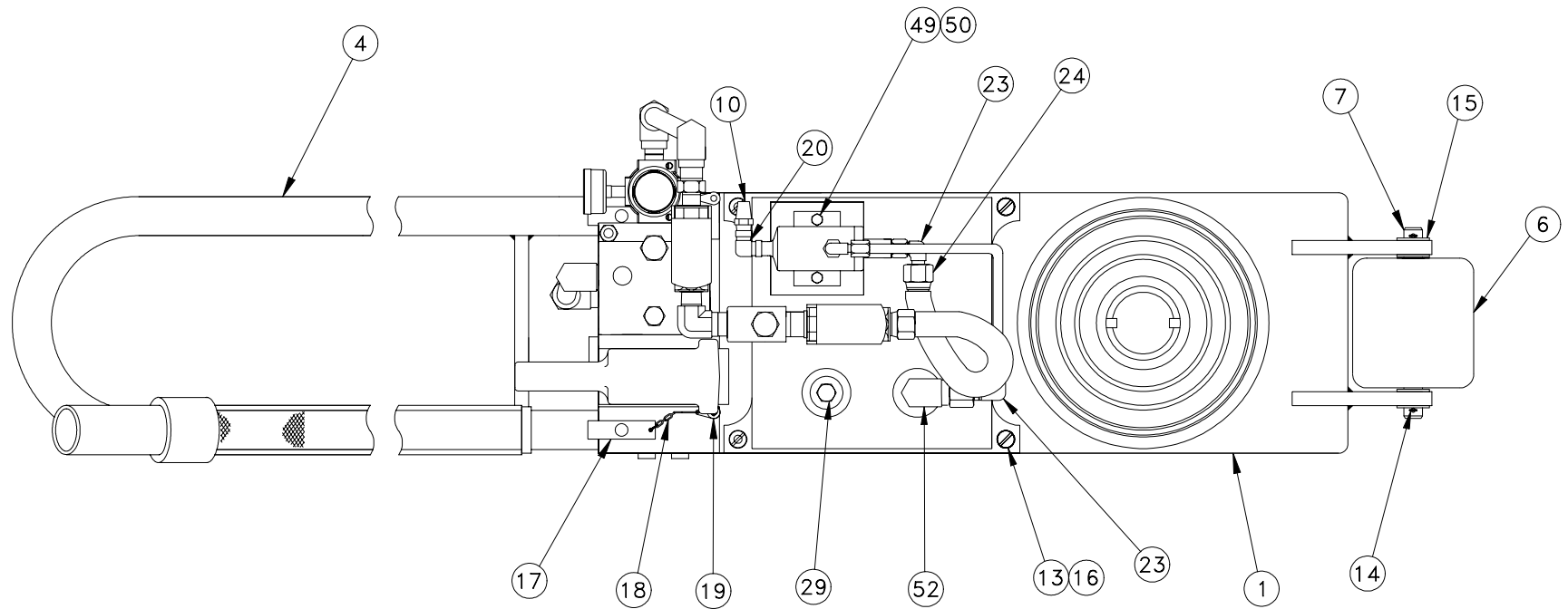

# ColumbusJACK/Regent

Model 5007-56FT  
50 Ton Flyaway Axle Jack  
Page 4 of 6  
Figure 1

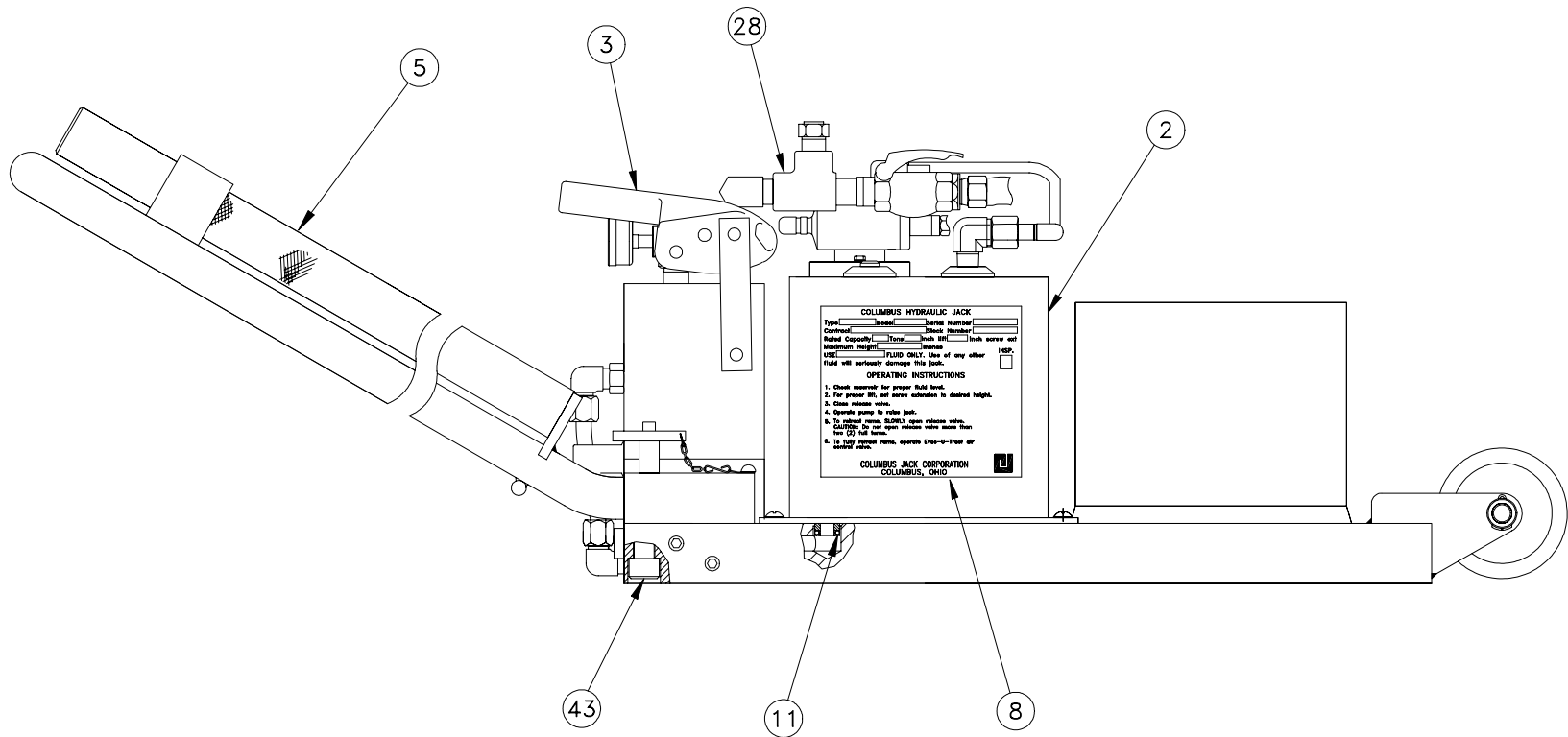

# ColumbusJACK/Regent

Model 5007-56FT  
50 Ton Flyaway Axle Jack  
Page 5 of 6  
Figure 1

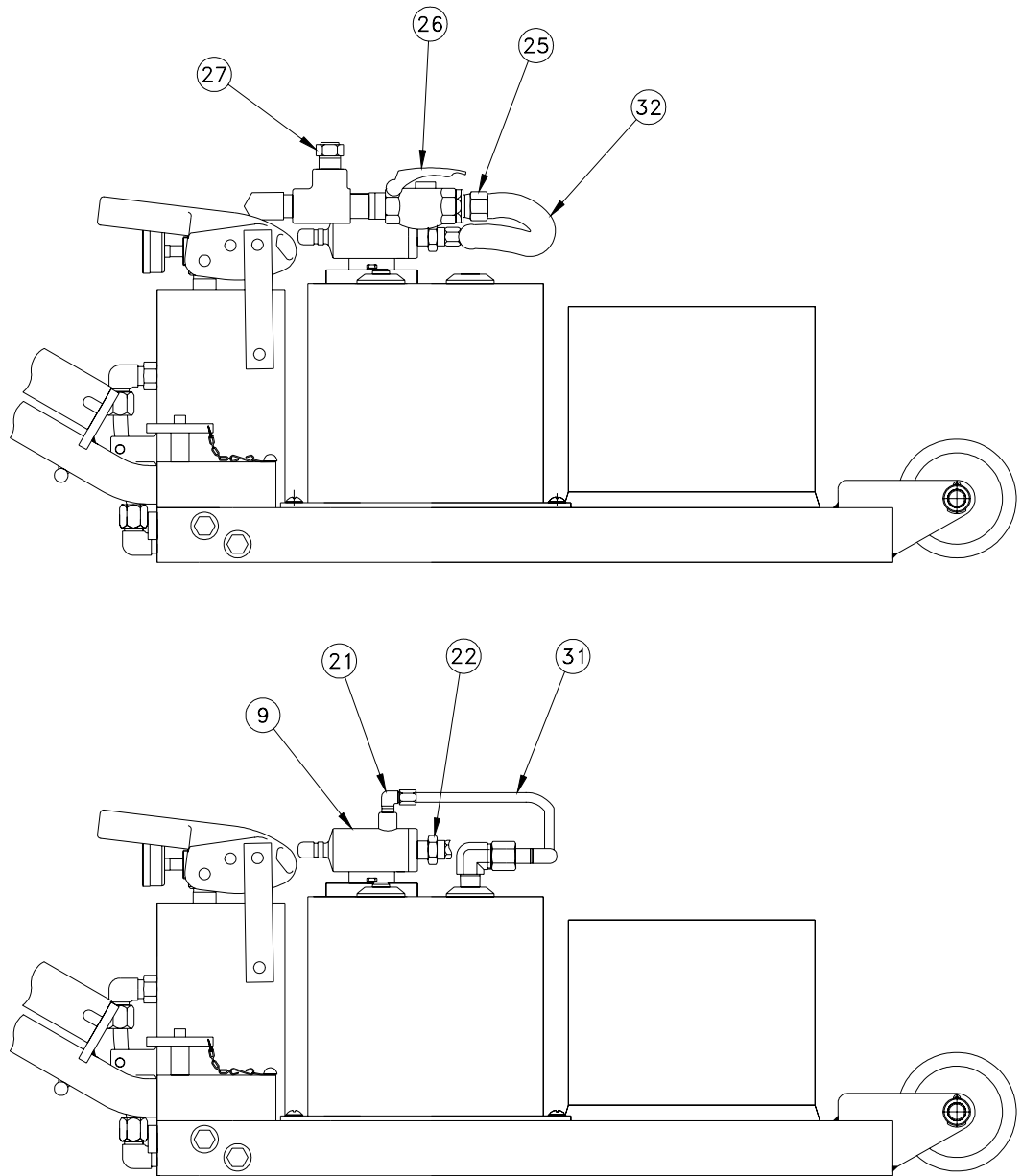

NOTE: SOME ITEMS REMOVED FOR CLARITY

# ColumbusJACK/Regent

Model 5007-56FT  
50 Ton Flyaway Axle Jack  
Page 6 of 6  
Figure 1

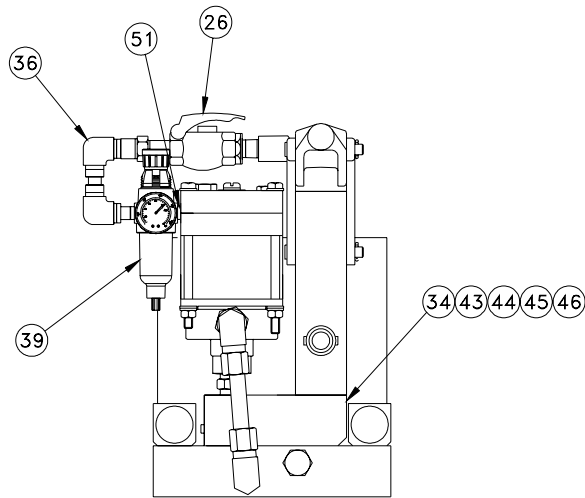
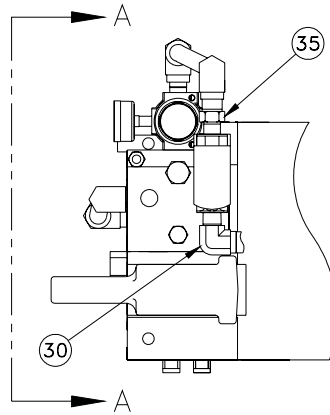

VIEW A-A

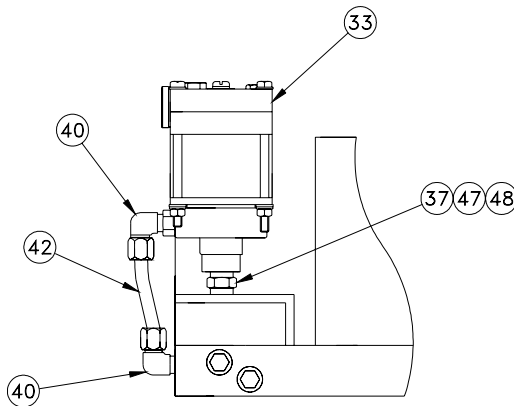

NOTE: SOME ITEMS REMOVED FOR CLARITY

# ColumbusJACK/Regent

Model 5007-56FT  
 50 Ton Flyaway Axle Jack  
 Page 1 of 2  
 Figure 2

FIG. & ITEM NO.	PART NUMBER	DESCRIPTION	UNITS PER ASS'Y
<b>2-</b>	<b>150C1200</b>	<b>Lift Assembly.....</b>	<b>Ref.</b>
-1	875C1201	Cylinder Weldment.....	1
-2	150B1202	Ram, First Stage.....	1
-3	150B1203	Ram, Second Stage.....	1
-4	150B1204	Ram, Third Stage Ram.....	1
-5	871B1205	Extension Screw.....	1
-6	871B1206	Bearing.....	1
-7	871B1207	Nut.....	1
-8	611-43043	O-Ring.....	1
-9	611-34734	O-Ring.....	1
-10	611-33933	O-Ring.....	1
-11	512C1100-14	Backup Ring.....	1
-12	512C1100-13	Backup Ring.....	1
-13	512C1100-12	Backup Ring.....	1
-14	312-10021	Set Screw.....	1
-15	Not Used		
-16	488-00004	Pipe Plug.....	3
-17	450A7020	Plug.....	1
-18	611-01301	O-Ring.....	1
-19	871B1211-1	Retainer Ring.....	1
-20	871B1211-2	Retainer Ring.....	1

# ColumbusJACK/Regent

Model 5007-56FT  
50 Ton Flyaway Axle Jack  
Page 2 of 2  
Figure 2

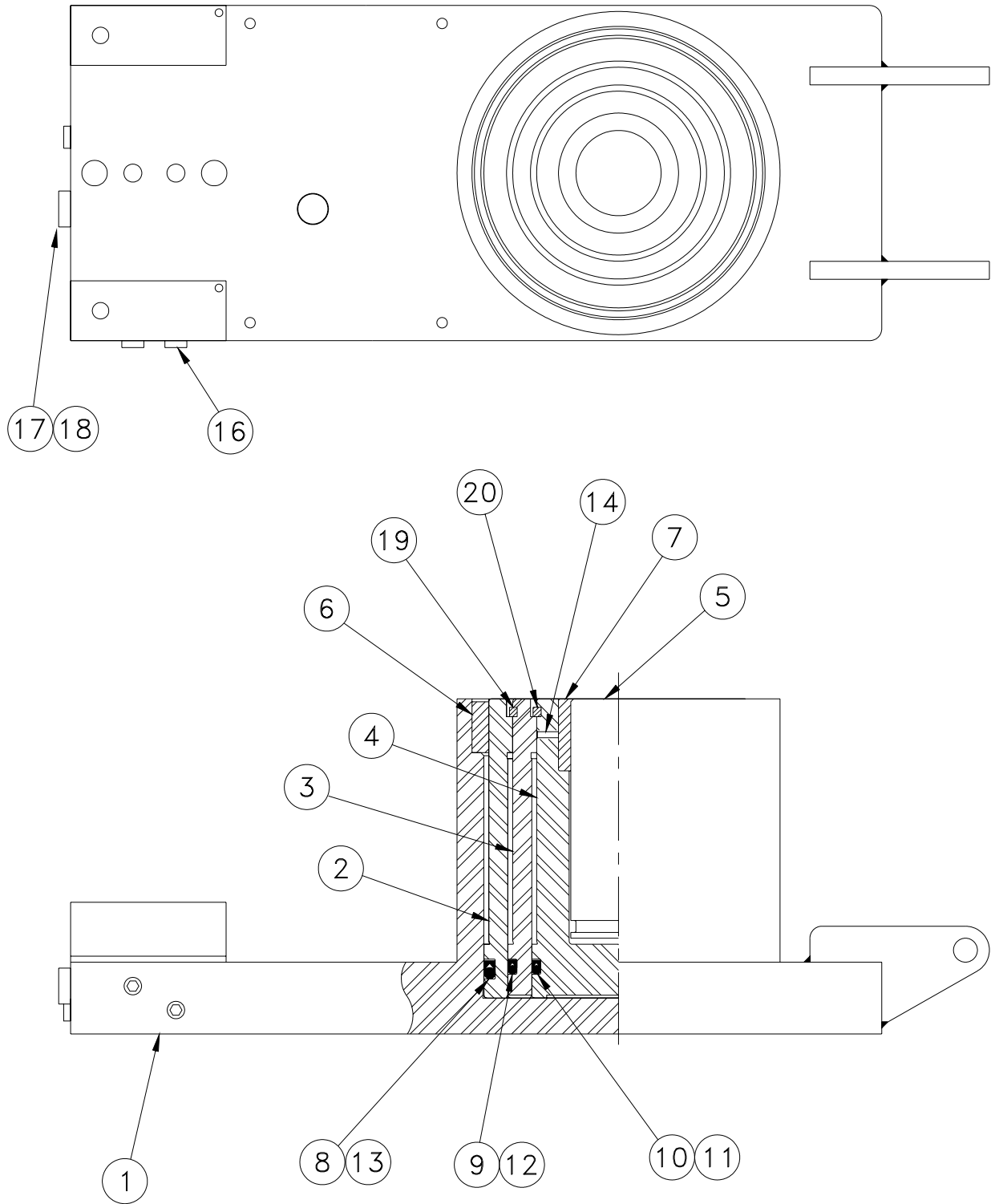

# ColumbusJACK/Regent

Model 5007-56FT  
 50 Ton Flyaway Axle Jack  
 Page 1 of 2  
 Figure 3

FIG. & ITEM NO.	PART NUMBER	DESCRIPTION	UNITS PER ASS'Y
<b>3-</b>	<b>566-02</b>	<b>Pump Assembly .....</b>	<b>Ref.</b>
-1	30-182	Base, Pump .....	1
-2	70-88	Plunger .....	1
-3	230-23	Fulcrum .....	1
-4	220-19	Link .....	2
-5	20-118	Body, Valve .....	1
-6	20-2-23	Needle .....	1
-7	216-1-18	Ball .....	2
-8	20-2-51	Set Screw, Relief Valve .....	1
-9	250A024-1	Filter Screen .....	1
-10	240-14	Spring .....	1
-11	240-9-01	Spring .....	1
-12	566-01-19	Rubber Plug .....	1
-13	Not Used		
-14	488-00002	Pipe Plug .....	1
-15	321-14690	Clevis Pin .....	2
-16	322-03560	Cotter Pin .....	1
-17	322-03160	Cotter Pin .....	3
-18	321-14490	Clevis Pin .....	1
-19	325-12080	Spring Pin .....	1
-20	566-02-10	Wiper .....	1
-21	618-10091	Backup Ring .....	1
-22	611-11111	O-Ring .....	1
-23	611-11311	O-Ring .....	3
-24	611-01201	O-Ring .....	1
-25	611-01001	O-Ring .....	1

# ColumbusJACK/Regent

Model 5007-56FT  
50 Ton Flyaway Axle Jack  
Page 2 of 2  
Figure 3

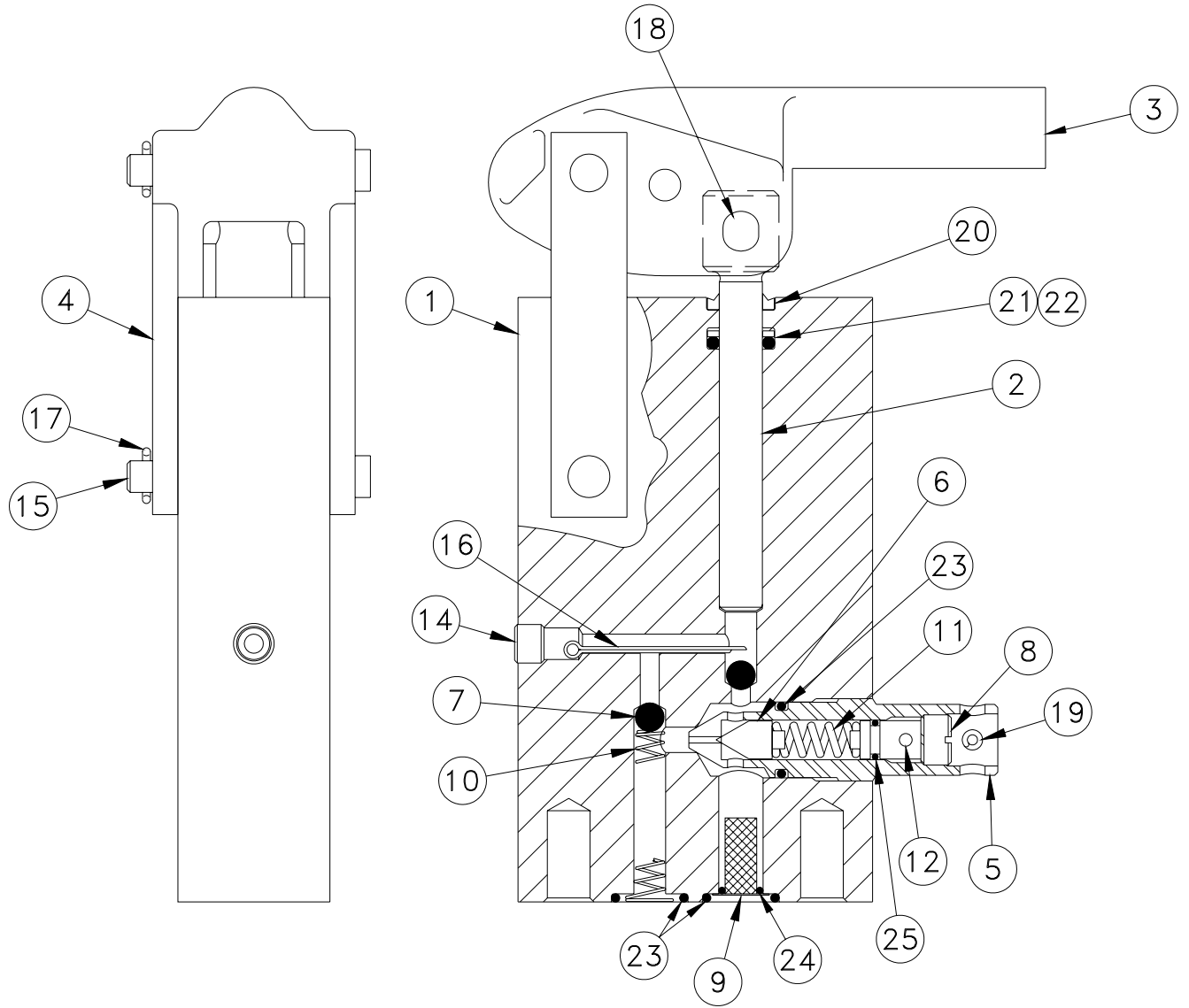

# Appendix



# **ROUTINE JACK MAINTENANCE BULLETIN**

RJM 102

1 OF 1

## **TO PROVIDE COMPLETE INFORMATION ON SERVICING ColumbusJACK/REGENT QUALITY GROUND HANDLING EQUIPMENT**

### **PROCEDURE FOR WINTERIZATION OF HYDRAULIC AIRCRAFT JACKS**

The following procedures should be utilized for optimum operational characteristics when using jacks at various temperature extremes:

- 1) Above 0°F (-18°C)

Use MIL-H-5606, or equal, with no further additive required.

- 2) At 0°F (-18°C) to -20°F (-29°C)

Use a mixture of 75% MIL-H-5606, or equal, and 25% kerosene.

- 3) Below -20°F (-29°C)

Use a mixture of 50% MIL-H-5606, or equal, and 50% kerosene.

Due to most company, safety, or union regulations which restrict employees from working out-of-doors below -30°F (-34°C), there is a lack of experience beyond this point. It is permissible, however, to increase the percentage of kerosene up to 100%. As the ambient temperature increases, MIL-H-5606, should be added back to the system in the appropriate mixture.

The air supply should be clean and dry. At -30°F (-34°C), the air pump will start to react sluggishly and continue to operate less efficiently as the temperature decreases when a normal air supply is used. The problem can be eliminated by using a dry nitrogen source of sufficient capacity.

To ease the operation of the locknut(s) and screw extension, use "Never Freeze" by Snap-On, or equal, and apply liberally to the thread surfaces.



# **ROUTINE JACK MAINTENANCE BULLETIN**

RJM 116

1 OF 1

**TO PROVIDE COMPLETE INFORMATION ON SERVICING  
ColumbusJACK/REGENT QUALITY GROUND HANDLING EQUIPMENT**

## **SCREW EXTENSION USAGE**

When using a jack that has a screw extension, it is advisable that the screw extension be extended as far as possible, and still have the jack roll under the jacking point. If the screw extension is not properly extended, the aircraft may not be able to be raised to the desired height.

A periodic check should be made to the screw extension to ensure that the stop is operating properly to prevent over-extension. To do this, rotate the screw extension counterclockwise until it stops rotating. **DO NOT FORCE THE SCREW EXTENSION BEYOND THIS POINT**. If the screw extension does not stop rotating, remove it and repair the stop. **DO NOT USE WITHOUT THE SCREW EXTENSION STOP WORKING PROPERLY, AS THE JACK COULD FAIL WITH AN OVER-EXTENDED SCREW EXTENSION.**



# ***ROUTINE JACK MAINTENANCE BULLETIN***

RJM 147

1 OF 1

## **TO PROVIDE COMPLETE INFORMATION ON SERVICING ColumbusJACK/REGENT QUALITY GROUND HANDLING EQUIPMENT**

### **RECOMMENDED ANNUAL JACK CERTIFICATION PROCEDURE**

To ensure proper operation of all aircraft hydraulic jacks, it is important that at a minimum, each jack is certified on an annual basis. The following procedure is provided as an aid to the certification process.

- 1) With no external load applied to the jack, fully close release valve and fully extend ram(s) to verify function and the absence of external hydraulic leakage.
- 2) Open release valve and verify ram(s) retract fully.
- 3) Position jack under jack tester.
- 4) Close release valve, and extend ram(s):
  - a) Single Stage Cylinder - Extend ram at least 2 inches.
  - b) Multi-Stage Cylinder - Fully extend all but the last stage. Extend the last stage at least 2 inches.
- 5) Pressurize the jack against the jack tester. Using a calibrated pressure gauge on either the jack or the jack tester, monitor the pressure until the capacity (operating pressure) of the jack is reached.
- 6) With the jack pressurized against the jack tester, hold in this position for 3 minutes. Verify that the jack pressure has not decreased, indicating internal leakage.
- 7) Open the release valve to relieve jack pressure against the jack tester.
- 8) Set the safety relief valve per jack operation and maintenance manual.



# ROUTINE JACK MAINTENANCE BULLETIN

RJM 149

1 OF 1

## TO PROVIDE COMPLETE INFORMATION ON SERVICING ColumbusJACK/REGENT QUALITY GROUND HANDLING EQUIPMENT

### TEFLON BACKUP RING INSTALLATION PROCEDURE

When installing new Teflon backup rings on a ram or piston of any jack model, the following procedure should be observed to ensure correct installation of the ring. When installing a new backup ring, the corresponding o-ring should always be replaced also.

- 1) Cut existing o-ring and Teflon backup ring.
- 2) Clean and visually inspect the groove in the ram or piston for any nicks, scratches or score marks, which could cut the o-ring and backup ring during installation.
- 3) Check to ensure backup ring is clean and not damaged.
- 4) Set backup ring on a flat metal surface.
- 5) Using a propane torch, heat backup ring in a circular motion until backup ring is equally softened and pliable or flexible.
- 6) Carefully pick-up the **HOT** Teflon backup ring off the **HOT** metal plate and stretch the ring enough to fit over the end of the ram (piston). **NOTE: Make sure the "V" cup portion of the backup ring will face the o-ring.** (See figure)
- 7) If backup ring does not return to size after cooling, re-heat backup ring while on the part, and cool quickly with a cold, wet towel or rag.
- 8) Check to ensure o-ring is clean and not damaged.
- 9) Carefully stretch o-ring over the end of the ram (piston). Ensure that the o-ring and the "V" cup of the backup ring are facing each other. (See figure)

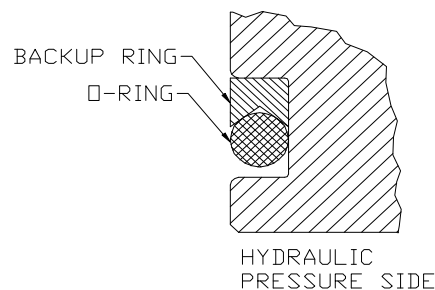



# **ROUTINE JACK MAINTENANCE BULLETIN**

RJM 170

1 OF 1

## **TO PROVIDE COMPLETE INFORMATION ON SERVICING ColumbusJACK/REGENT QUALITY GROUND HANDLING EQUIPMENT**

### **SUGGESTED PREVENTATIVE MAINTENANCE FOR JACKS**

The following Preventative Maintenance Schedule is provided as a guide to insure that hydraulic aircraft jacks are always ready for operation. The time intervals listed are a general recommendation only. The actual interval used should include factors for the climatic conditions in which the equipment is stored and the frequency of equipment use.

#### Prior to Operation

1. Inspect for damaged or missing components.
2. Inspect for oil leakage and proper fluid level.
3. Inspect screw extension for mechanical stop.
4. Inspect all snap rings for engagement into grooves.
5. Inspect jack adapter for damage.

#### Every 6 Months

1. Inspect for worn snap ring grooves.
2. Change hydraulic filters if applicable.
3. If jack has not been used regularly, cycle jack without load.
4. Grease all lube fittings with a general purpose grease.
5. Wipe down ram(s) and screw extension with hydraulic oil.

#### Every 12 Months

1. Calibrate pressure gauge if applicable per RJM 173.
2. Perform "Recommended Annual Jack Certification Procedure" per RJM 147.



# **ROUTINE JACK MAINTENANCE BULLETIN**

RJM 171

1 OF 1

**TO PROVIDE COMPLETE INFORMATION ON SERVICING  
ColumbusJACK/REGENT QUALITY GROUND HANDLING EQUIPMENT**

## **RECOMMENDED HYDRAULIC OILS**

The following hydraulic oils are recommended for use in all ColumbusJACK/Regent products, though any oil compatible with Buna-N seals may be used. Proper oil level should be .5 to 1 inch below the fill port when all rams are collapsed.

- Exxon/Mobil Aero HF (MIL-5606)
- Exxon/Mobil DTE-11, -15
- Phillips 66 X/C 5606
- Royco 783 (Anderol) (MIL-PRF-6083)
- Shell Tellus 10, 15
- Shell Aerofluid 31 (MIL-PRF-83282)
- Shell Aerofluid 41 (MIL-PRF-5606)
- Texaco Regal Oil R & O (32, 46, 100, 150, 220, 320, 460)



# **ROUTINE JACK MAINTENANCE BULLETIN**

RJM 207

1 OF 1

## **TO PROVIDE COMPLETE INFORMATION ON SERVICING ColumbusJACK/REGENT QUALITY GROUND HANDLING EQUIPMENT**

### **PROCEDURE FOR ADJUSTING 566 PUMP STYLE RELIEF VALVES**

It is imperative that safety relief valves on all jacks always be set between rated capacity, and rated capacity plus 10% maximum. The following procedure describes how to adjust 566 pump style relief valves.

- 1) Position jack under tester.
- 2) Fully close release valve.
- 3) Extend cylinder ram(s):
  - 3.1 On single stage jacks, extend the ram approximately half way.
  - 3.2 On multiple stage jacks, extend all rams until the smallest ram is extended approximately half way.

- 4) Remove spring pin on release valve cartridge.

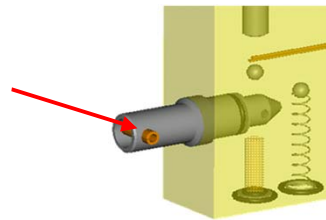

- 5) Using smooth, uniform pump handle strokes, manually pressurize the cylinder while monitoring either jack load gauge or load gauge on tester.
- 6) Pump handle shall "drop" or "go soft" at an indicated load between rated load and rated load plus 10% (ex: 50 ton jack should be between 50 and 55 tons).

- 7) If safety relief valve is set too high, release pressure and rotate adjusting screw counterclockwise.
- 8) If safety relief valve is set too low, release pressure and rotate adjusting screw clockwise.

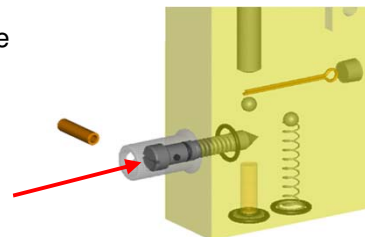

- 9) Repeat steps until valve is adjusted in range.
- 10) Open release valve and lower ram(s) completely.
- 11) Re-install spring pin. Jack is now ready for service.