



# OPERATION & SERVICE MANUAL



**Model: 08-4049-0013**  
**Engine Compressor Washer**

11/2023 - Rev. 05

**For Spare Parts, Operations & Service Manuals or Service Needs**  
**Scan the QR code or visit [Tronair.com/aftermarket](https://www.tronair.com/aftermarket)**



REVISION	DATE	TEXT AFFECTED
01	05/2008	Original Release
02	06/2021	Major revision
03	11/2021	Major revision
04	11/2022	Modified Parts List
05	11/2023	Modified 4.1.2 Fluid Agitation, 4.1.3 Cleaning Operation, 4.1.4 Rinse Operation

**TABLE OF CONTENTS**

	<b><u>PAGE</u></b>
SCHEMATIC .....	1
<b>1.0 PRODUCT INFORMATION .....</b>	<b>2</b>
1.1 DESCRIPTION.....	2
1.2 MODEL & SERIAL NUMBER.....	2
1.3 MANUFACTURER .....	2
<b>2.0 SAFETY INFORMATION.....</b>	<b>2</b>
2.1 USAGE AND SAFETY INFORMATION .....	2
<b>3.0 TRAINING.....</b>	<b>2</b>
3.1 TRAINING REQUIREMENTS .....	2
3.2 TRAINING PROGRAM .....	2
3.3 OPERATOR TRAINING.....	2
<b>4.0 OPERATION.....</b>	<b>3</b>
4.1 PREPARATION & OPERATION.....	3
4.1.1 Preparation .....	3
4.1.2 Fluid Agitation .....	3
4.1.3 Cleaning Operation .....	3
4.1.4 Rinse Operation .....	3
<b>5.0 STORAGE.....</b>	<b>3</b>
<b>6.0 MAINTENANCE .....</b>	<b>4</b>
6.1 CLEANING FLUID TANKS .....	4
6.2 HOSES .....	4
6.3 AIR TANK MAINTENANCE .....	4
6.4 HYDROSTATIC TANK TEST.....	4
6.5 OUTPUT FILTER.....	4
<b>7.0 PROVISION OF SPARES.....</b>	<b>4</b>
7.1 SOURCE OF SPARE PARTS.....	4
7.2 RECOMMENDED SPARE PARTS LISTS .....	4
<b>8.0 IN-SERVICE SUPPORT.....</b>	<b>4</b>
<b>9.0 GUARANTEES/LIMITATION OF LIABILITY .....</b>	<b>5</b>
<b>10.0 APPENDICES .....</b>	<b>5</b>

**Schematic**

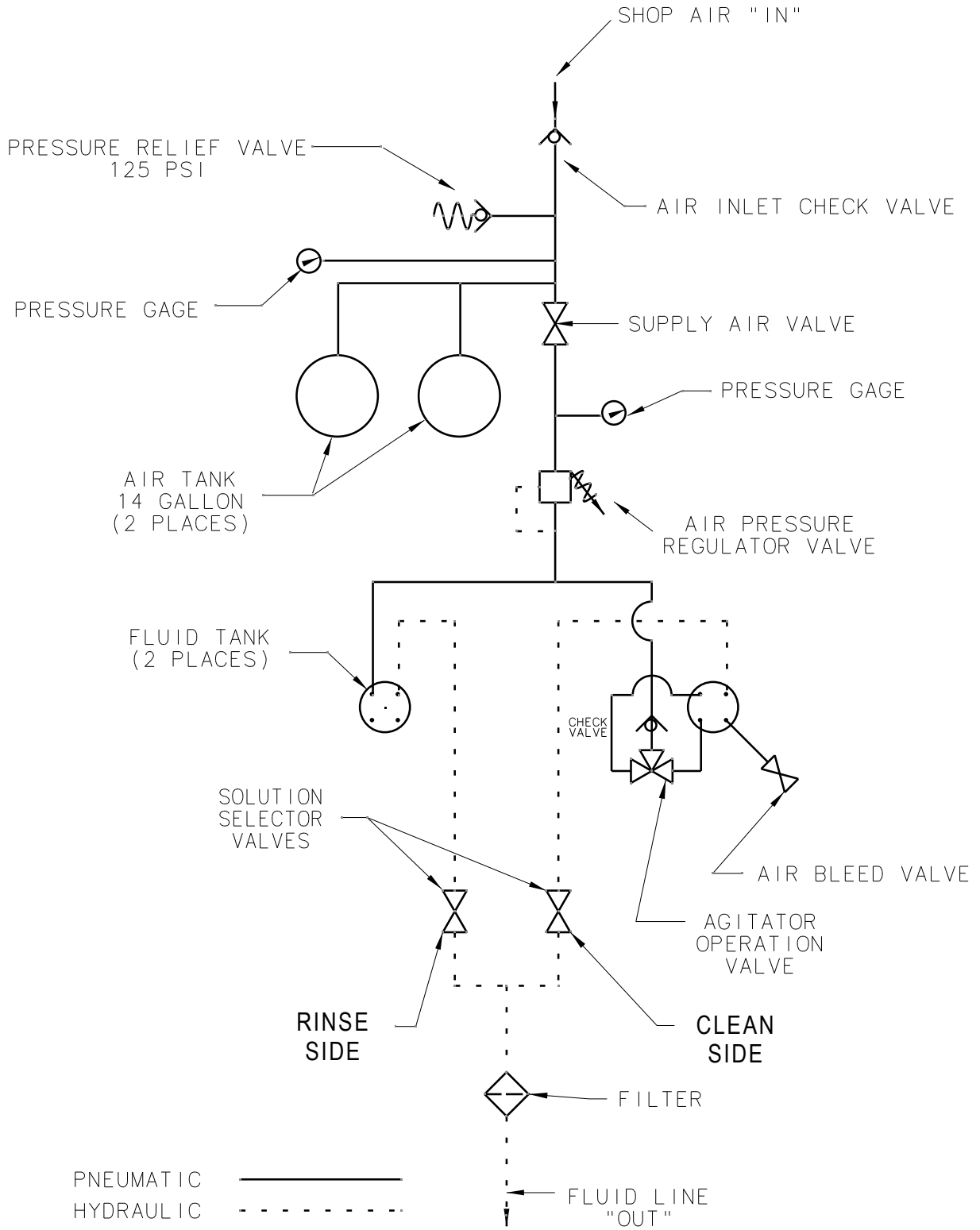

This product can not be modified without the written approval of Tronair, Inc. Any modifications done without written approval voids all warranties and releases Tronair, Inc., its suppliers, distributors, employees, or financial institutions from any liability from consequences that may occur. Only Tronair OEM replacement parts shall be used.

## 1.0 PRODUCT INFORMATION

### 1.1 DESCRIPTION

The Engine Compressor Washer is a portable unit designed to spray either cleaning solution and/or clean fresh water into jet and turboprop engines.

The two fluid tanks will hold 12 gallons each. The air tanks, when charged to 125 psi, provide sufficient volume to empty both fluid tanks. The nozzle mounted on the panel may be installed on the wand to regulate the fluid flow to the approximate rate as indicated.

### 1.2 MODEL & SERIAL NUMBER

Reference nameplate on unit

### 1.3 MANUFACTURER

**TRONAIR**, Inc.  
1 Air Cargo Pkwy East  
Swanton, Ohio 43558 USA

Telephone: (419) 866-6301 or 800-426-6301  
Fax: (419) 867-0634  
E-mail: sales@tronair.com  
Website: www.tronair.com

## 2.0 SAFETY INFORMATION

### 2.1 USAGE AND SAFETY INFORMATION

To insure safe operations please read the following statements and understand their meaning. Also refer to your equipment manufacturer's manual for other important safety information. This manual contains safety precautions which are explained below. Please read carefully.



**WARNING!** — Warning is used to indicate the presence of a hazard that **can cause severe personal injury, death, or substantial property damage** if the warning notice is ignored.

**CAUTION!** — Caution is used to indicate the presence of a hazard that **will or can cause minor personal injury or property damage** if the caution notice is ignored.

## 3.0 TRAINING

### 3.1 TRAINING REQUIREMENTS

The employer of the operator is responsible for providing a training program sufficient for the safe operation of the engine compressor washer.

### 3.2 TRAINING PROGRAM

The employer provided operator training program should cover safety procedures concerning use of the engine compressor washer in and around the intended aircraft at the intended aircraft servicing location.

### 3.3 OPERATOR TRAINING

The operator training should provide the required training for safe operation of the engine compressor washer.

**NOTE: Maintenance and Trouble Shooting are to be performed by a skilled and trained technician.**

## 4.0 OPERATION

### WARNING!



1. Personal injury may result if procedures are not followed.
2. Never open fluid tank while under pressure.
3. Never pressurize air tank more than 125 psi.

### CAUTION



1. Use only clean water and/or cleaning fluids approved by engine manufacturer.
2. Consult aircraft manual for correct procedure in performing engine wash.

## 4.1 PREPARATION & OPERATION

Follow engine manufacturer's recommendations for cleaning and rinsing engine(s). Use only engine manufacturer's approved fluids.

### 4.1.1 Preparation

1. Visually inspect unit for any signs of shipping damage or missing parts.
2. Ensure supply air valve on Control Panel is in the closed (Off) position.
3. Open air bleed to depressurize solution tanks.
4. Remove solution tank lids and fill respective tank with desired amount of fluid.
5. Close solution tank lids.
6. Attach shop air to air fill valve on Control Panel and charge air tanks to 125 psi (8.6 bar) maximum.
7. Unit is now ready for immediate use. If unit stands idle, agitate fluid before use.

### 4.1.2 Fluid Agitation

**NOTE: The valve must either be in the "AGITATE" or "WASH" position to pressurize solution tank.**

1. Fully charge air supply tanks. Turn agitation valve to "AGITATE" and ensure supply air valve is in the off position (closed).
2. Open air bleed valve on top of solution tank.
3. Set regulator to desired agitation pressure (30 psi recommended).
4. Slowly open supply air valve. When suds start coming out of the air bleed valve, or desired agitation is reached, close air bleed valve and turn the agitation valve to "WASH".

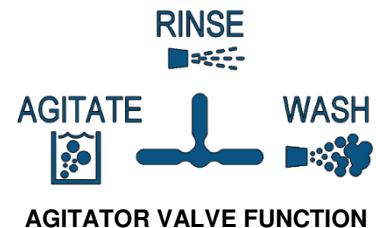

### 4.1.3 Cleaning Operation

1. Ensure tanks are charged and rinse and clean selector valves are closed and agitation valve is set to "WASH."
2. Connect output hose to engine or wand assembly.
3. Open supply air valve.
4. Adjust cleaning pressure by adjusting air regulator on Control Panel per engine manufacturer's recommendations.
5. Turn clean selector valve to Open when ready to start cleaning.
6. If using wand, point wand away from personnel and turn on wand valve to start cleaning process.
7. Upon completion of cleaning (or if tank has been emptied), turn wand valve off and/or close clean selector valve on Control Panel.

### 4.1.4 Rinse Operation

**NOTE: Agitator operation valve must be set to "RINSE" during rinse operation. Failure to do so may result in cleaning solution being discharged during rinse operation.**

1. Adjust rinsing pressure by adjusting air regulator on Control Panel per engine manufacturer's recommendations.
2. Set agitation valve to "RINSE."
3. Turn rinse selector valve to Open position on the Control Panel to start rinse.
4. If using wand, point wand away from personnel and turn on wand valve to start rinse process.
5. After completion of rinsing, turn wand valve Off and/or close rinse selector valve on Control Panel.

## 5.0 STORAGE

- Ensure fluid tanks are clean. (Reference Section 6.1)
- Clean the unit exterior prior to storage.
- Depressurize entire unit.

**6.0 MAINTENANCE****6.1 CLEANING FLUID TANKS**

**NOTE: For tank cleaning, wand must be attached to output hose to let fluid discharge.**

After each use, complete the following:

1. Close supply air valve.
2. Open air bleed valve, let tanks de-pressurize.
3. Remove cleaning tank lid and fill with approximately one gallon (3.8 L) of water.
4. Close cleaning tank lid and air bleed valve. Open supply air valve.
5. Open clean selector valve and wand valve.
6. Close supply air valve when tank is empty.
7. Close clean selector valve, wand valve. Open air bleed valve.

**6.2 HOSES**

Replace worn hoses as required.

**6.3 AIR TANK MAINTENANCE**

Periodically drain air tank by opening plug valve at bottom of air tank to remove any condensation that may have accumulated during use.

Hydrostatically or pneumatically test tank(s) as required due to physical damage, or as required by local law.

**6.4 HYDROSTATIC TANK TEST**

Hydrostatically test tank as required due to physical damage, or as required by local law.

A hydrostatic test is the most common way in which a cylinder is checked for leaks or flaws. During a hydrostatic test, the cylinder is examined to ensure it can safely hold its rated pressure. Testing is crucial as such containers can explode if they fail when containing compressed gas.

A hydrostatic test consists of filling the cylinder with a nearly incompressible liquid, usually water, and examining it for leaks or permanent changes in shape. The test pressure is always considerably more than the operating pressure to give a margin for safety. Typically, 150% of the operating pressure is used. Water is commonly used as it is almost incompressible, and will only expand by a very small amount. If high pressure gas was used, the gas could expand up to several hundred times its compressed volume, running the risk of serious injury.

**6.5 OUTPUT FILTER**

1. Periodically inspect filter for cleanliness. Clean with fresh water.
2. Replace filter element when fluid flow is hindered.

**7.0 PROVISION OF SPARES****7.1 SOURCE OF SPARE PARTS**

Spare parts may be obtained from the manufacturer:

<b>TRONAIR, Inc.</b>	Telephone: (419) 866-6301 or 800-426-6301
1 Air Cargo Pkwy East	Fax: (419) 867-0634
Swanton, Ohio 43558 USA	E-mail: sales@tronair.com
	Website: www.tronair.com

For Spare Parts, Operations & Service Manuals or Service Needs:  
Scan the QR code or visit [Tronair.com/aftermarket](http://Tronair.com/aftermarket)

**7.2 RECOMMENDED SPARE PARTS LISTS**

Reference the following page(s) for Replacement Parts and Kits available.

**8.0 IN-SERVICE SUPPORT**

Contact Tronair for technical services and information.



**9.0 GUARANTEES/LIMITATION OF LIABILITY**

Tronair products are warranted to be free of manufacturing or material defects for a period of one year after shipment to the original customer. This is solely limited to the repair or replacement of defective components. This warranty does not cover the following items:

- a) Parts required for normal maintenance
- b) Parts covered by a component manufacturers warranty
- c) Replacement parts have a 90-day warranty from date of shipment

If you have a problem that may require service, contact Tronair immediately. Do not attempt to repair or disassemble a product without first contacting Tronair, any action may affect warranty coverage. When you contact Tronair be prepared to provide the following information:

- a) Product Model Number
- b) Product Serial Number
- c) Description of the problem

If warranty coverage is approved, either replacement parts will be sent or the product will have to be returned to Tronair for repairs. If the product is to be returned, a Return Material Authorization (RMA) number will be issued for reference purposes on any shipping documents. Failure to obtain a RMA in advance of returning an item will result in a service fee. A decision on the extent of warranty coverage on returned products is reserved pending inspection at Tronair. Any shipments to Tronair must be shipped freight prepaid. Freight costs on shipments to customers will be paid by Tronair on any warranty claims only. Any unauthorized modification of the Tronair products or use of the Tronair products in violation of cautions and warnings in any manual (including updates) or safety bulletins published or delivered by Tronair will immediately void any warranty, express or implied.

The obligations of Tronair expressly stated herein are in lieu of all other warranties or conditions expressed or implied. **Any unauthorized modification of the Tronair products or use of the Tronair products in violations of cautions and warnings in any manual (including updates) or safety bulletins published or delivered by Tronair will immediately void any warranty, express or implied and Tronair disclaims any and all liability for injury (WITHOUT LIMITATION and including DEATH), loss or damage arising from or relating to such misuse.**

**10.0 APPENDICES**

APPENDIX I Flat Spray Nozzles

**Parts List**

When ordering replacement parts/kits, please specify model, serial number and color of your unit.

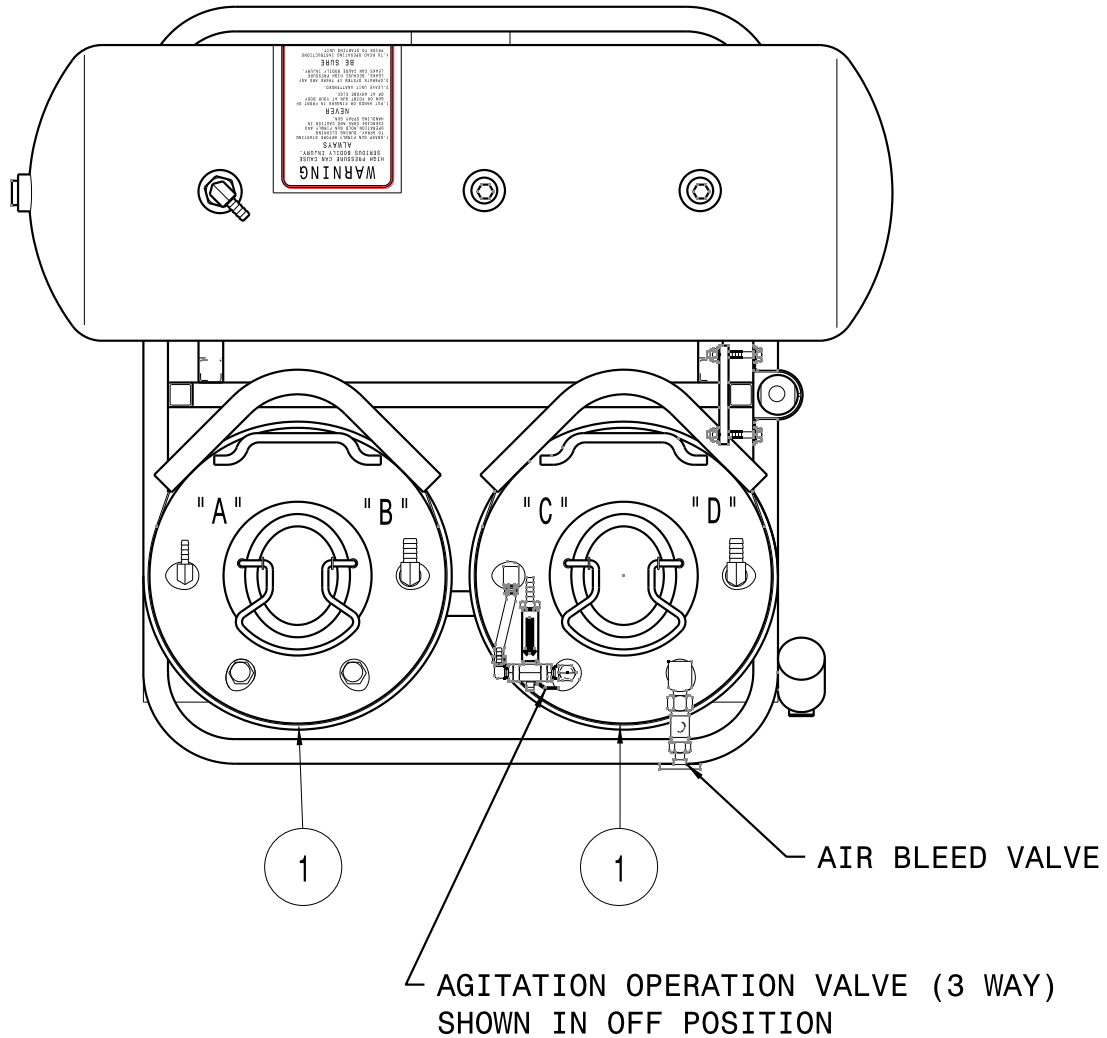

Item	Part Number	Description	Qty
1	B-405	VESSEL, PRESSURE	2
N/S	HC-1400	O-RING, CLOSURE	2
N/S	Z-11842	KIT, LID REPLACEMENT ASSEMBLY	

**Parts List**

When ordering replacement parts/kits, please specify model, serial number and color of your unit.

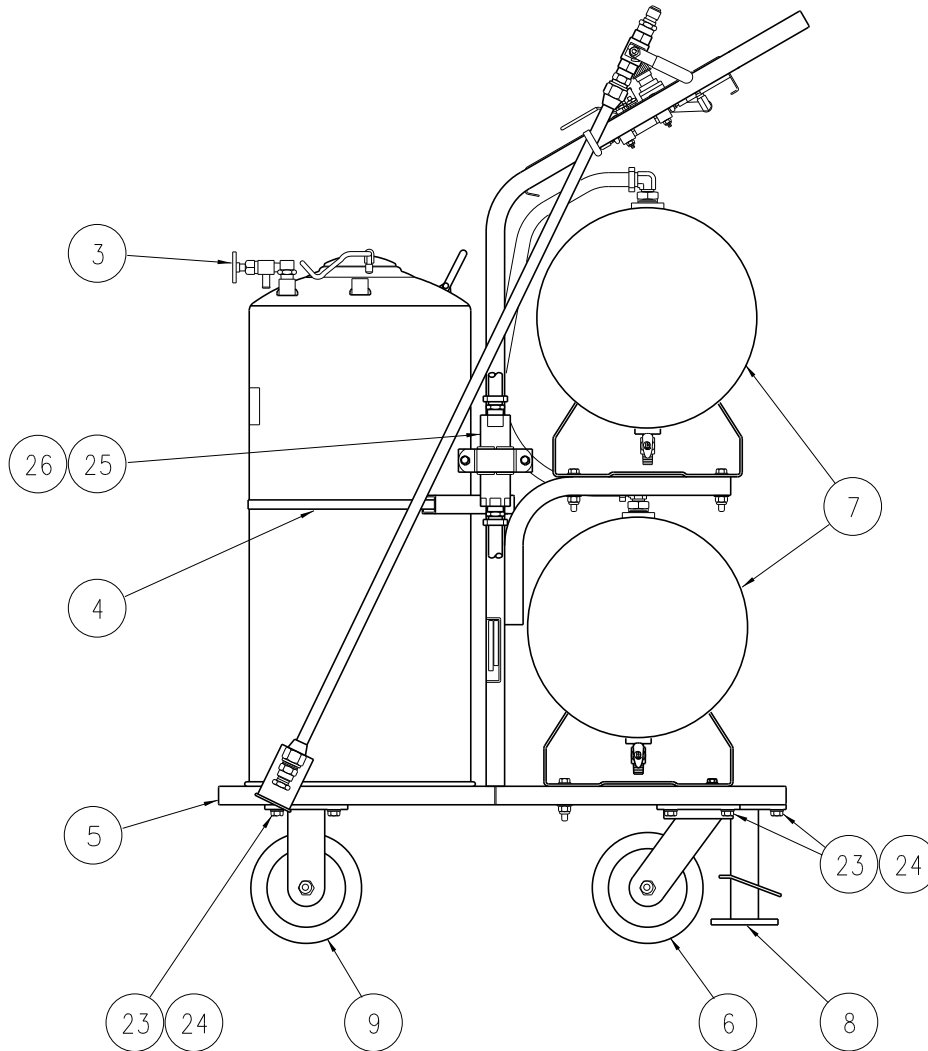

Item	Part Number	Description	Qty
3	H-1529-01	VALVE, SHUT-OFF	1
4	H-1550-14	CLAMP, SNAPLOCK	2
5	Z-6700-01	WELDMENT, FRAME	1
6	U-1014	CASTER, SWIVEL	2
7	PC-1080-01	TANK, AIR	2
8	H-1175	LOCK, FLOOR	1
9	U-1013	CASTER, RIGID	2
23	G-1180-107004	SCREW, 3/8 HEX HEAD, TPG TYPE F	16
24	G-1253-03	LOCKWASHER, EXTERNAL TOOTH	16
25	H-2792	FILTER, OUTPUT	1
26	H-2808	ELEMENT, REPLACEMENT	Ref

## Parts List - Control Panel Top View

When ordering replacement parts/kits, please specify model, serial number and color of your unit.

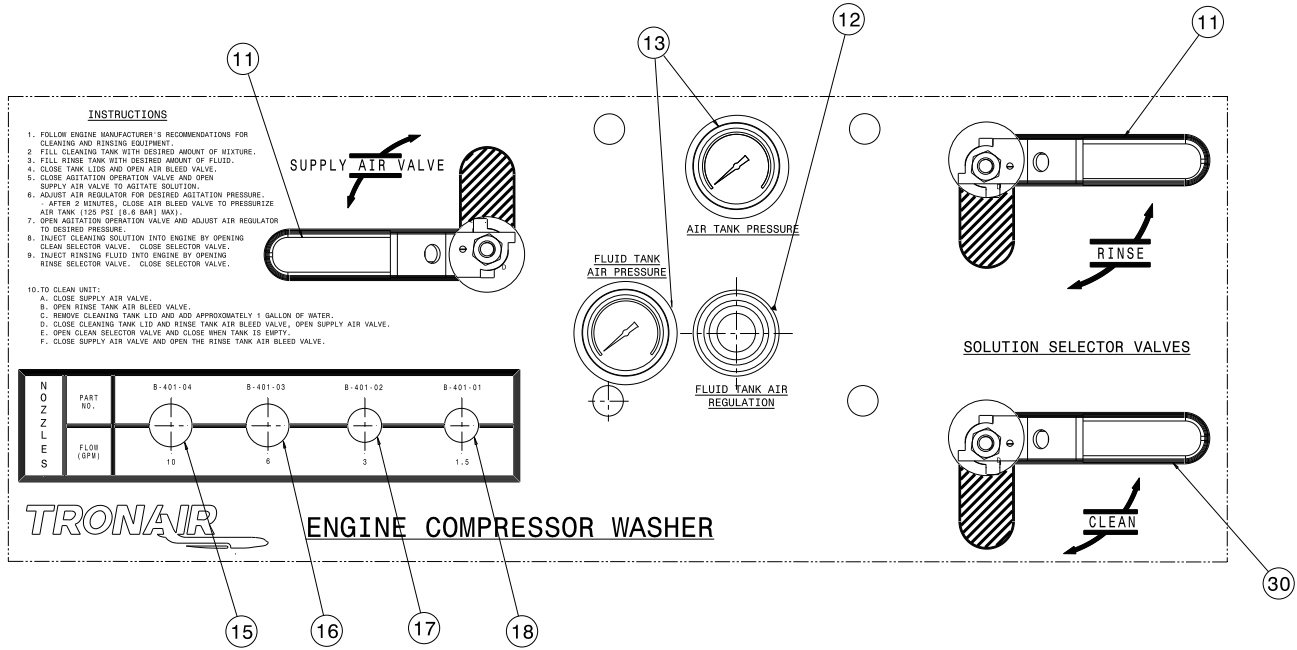

Item	Part Number	Description	Qty
11	HC-2416	VALVE, BALL	2
12	H-3033	REGULATOR	1
13	HC-1831	GAUGE, PRESSURE	2
15	B-401-04	3/8 NOZZLE, 10 GPM	1
16	B-401-03	3/8 NOZZLE, 6 GPM	1
17	B-401-02	1/4 NOZZLE, 3 GPM	1
18	B-401-01	1/4 NOZZLE, 1.5 GPM	1
30	HC-2350-03	VALVE, BALL 1/2 NPT	1

**Parts List –Control Panel Bottom View**

When ordering replacement parts/kits, please specify model, serial number and color of your unit.

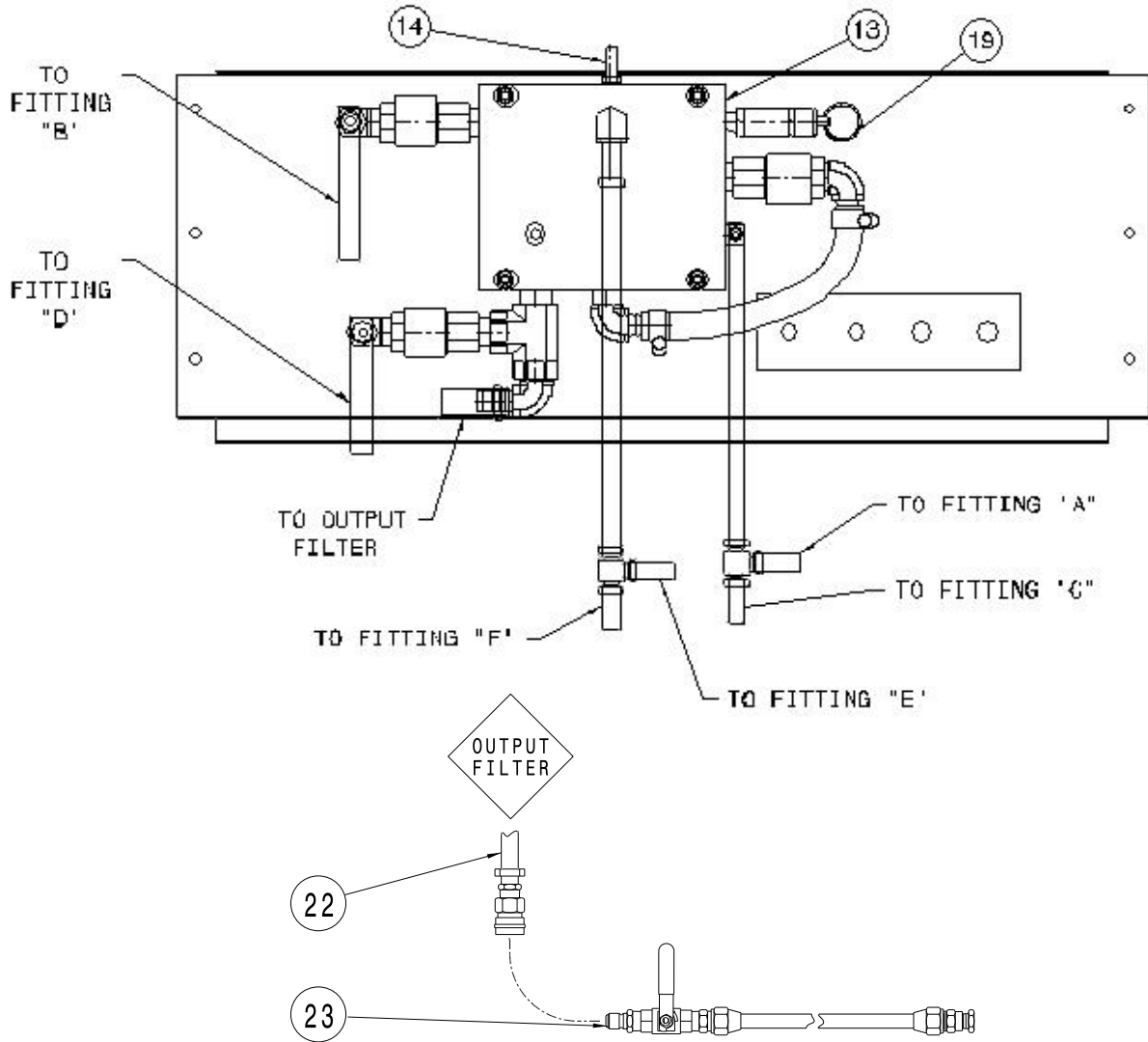

Item	Part Number	Description	Qty
13	J-4306	MANIFOLD	1
14	H-3208	VALVE AIR, ¼ NPT	1
19	PC-1017-02-125	VALVE SAFETY, 125 PSI	1
22	<b>K-1410</b>	<b>KIT, HOSE ASSEMBLY REPLACEMENT;</b> consists of:	
	H-1426-02	CLAMP, HOSE	1
	H-1516-13	CLAMP, 2 EAR HOSE	1
	N-2402-041-B	SOCKET, FEMALE	1
	N-2412-16	CONNECTOR, STRAIGHT MALE	1
	TF-1064-08*240	HOSE, 20 FT BLUE	1
23	<b>K-1411</b>	<b>KIT, WAND ASSEMBLY REPLACEMENT;</b> consists of:	
	HC-1137	VALVE, BALL	1
	N-2009-16-B	CONNECTOR, MALE	1
	N-2010-13-B	CONNECTOR, FEMALE	1
	N-2210-05-B	REDUCER, PIPE THREAD	1
	N-2403-04-B	PLUG, MALE THREAD	1
	Z-1890	ASSEMBLY, TUBE WAND	1

### Optional Adapter Kits

When ordering replacement parts/kits, please specify model, serial number and color of your unit.

Part Number	Application
K-1037	DEHAVILLAND DASH 7
K-1057	GARRETT TPE331
K-1152	PRATT & WHITNEY PT6A
K-1243	CESSNA CARAVAN
K-1357	SAAB 340
K-1709	DEHAVILLAND DHC6
K-1710	CANADAIR CHALLENGER
K-1953	ALLISON 250 - C20J, BELL 206 - JR3
K-1269	BEECH KING AIR 200
K-2248	GENERAL ELECTRIC CFM56
K-4364	GE T700-GE-701K

### Fuel Nozzle Cleaning Kit

Model	Part Number	Description
08-4049-0013	K-4243	PT6 PW 100 SERIES FUEL NOZZLE PULSE CLEANER





## **APPENDIX I**

### **Flat Spray Nozzles**



## FLAT SPRAY NOZZLES

- Flat spray nozzles are ideal for use in spray headers or manifolds. They produce a fan-type, tapered-edge spray pattern to ensure even coverage when multiple nozzles are used in a series
- Solid stream (0° spray angle) available to achieve highest impact of any nozzle type
- Consistent performance over the industry's largest range of flow rates and pressures
- Some models feature an integral strainer
- High pressure/high impact versions available
- Quick-connect versions available to speed maintenance and installation

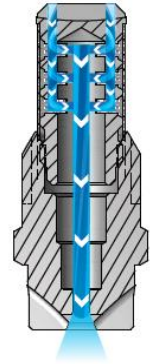

As the liquid exits through the sharp V shape cut of the orifice, it forms into a flat spray pattern. The distribution is tapered from the center of the spray.

PERFORMANCE DATA: STANDARD ANGLE SPRAY																				
P/N	Spray Angle at 40 psi	Nozzle Type Inlet Conn (in.)			Capacity Size	Equiv. Orifice Dia. (in.)	Flow Rate Capacity (gallons per minute)										Spray Angle (°)			
		H-U					5 psi	10 psi	20 psi	40 psi	80 psi	100 psi	200 psi	300 psi	500 psi	20 psi	40 psi	80 psi	200 psi	
		1/4	3/8	1/2																
B-401-01	50°	●			50	.172	1.8	2.5	3.5	5.0	7.1	7.9	11.2	13.7	17.7	46	50	54	59	
B-401-02	40°	●			60	.188	2.1	3.0	4.2	6.0	8.5	9.5	13.4	16.4	21	35	40	45	48	
B-401-03	50°		●		50	.172	1.8	2.5	3.5	5.0	7.1	7.9	11.2	13.7	17.7	46	50	54	59	
B-401-04	15°		●		100	.243	3.5	5.0	7.1	10.0	14.1	15.8	22	27	35	13	15	17	18	
B-401-05	65°		●		15	.094	.53	.75	1.1	1.5	2.1	2.4	3.4	4.1	5.3	56	65	70	73	
B-401-06	40°			●	100	.243	3.5	5.0	7.1	10.0	14.1	15.8	22	27	35	34	40	43	46	

Highlighted column shows the rated pressure.