



OPERATION & SERVICE MANUAL



**Model: 06-5004C0500
Fluid Service Unit**



10/2017 – Rev. 02

REVISION	DATE	TEXT AFFECTED
01	08/2011	Original release
02	10/2017	Major revision



TABLE OF CONTENTS

	<u>PAGE</u>
1.0 PRODUCT INFORMATION	1
1.1 DESCRIPTION.....	1
1.2 MODEL & SERIAL NUMBER.....	1
1.3 MANUFACTURER	1
1.4 SPECIFICATIONS	1
1.5 FEATURES.....	1
2.0 PREPARATION FOR USE	1
3.0 TRAINING	1
3.1 TRAINING REQUIREMENTS	1
3.2 TRAINING PROGRAM	1
3.3 OPERATOR TRAINING	1
4.0 OPERATION	2
4.1 FLUID SERVICE UNIT OPERATION.....	2
4.2 COMPONENT TESTING	2
5.0 TROUBLE SHOOTING	2
6.0 MAINTENANCE	2
6.1 REMOVING AND SERVICING PUMP	2
6.2 FILTER MAINTENANCE.....	2
7.0 PROVISION OF SPARES.....	3
7.1 SOURCE OF SPARE PARTS.....	3
7.2 RECOMMENDED SPARE PARTS LISTS	3
8.0 IN SERVICE SUPPORT.....	3
9.0 GUARANTEES/LIMITATION OF LIABILITY	3
10.0 APPENDICES	3



This product can not be modified without the written approval of Tronair, Inc. Any modifications done without written approval voids all warranties and releases Tronair, Inc., its suppliers, distributors, employees, or financial institutions from any liability from consequences that may occur. Only Tronair OEM replacement parts shall be used.

1.0 PRODUCT INFORMATION

1.1 DESCRIPTION

The Tronair Fluid Service Unit is a compact unit designed to provide a source of clean, pressurized fluid for filling reservoirs, bleeding brakes and other maintenance functions.

1.2 MODEL & SERIAL NUMBER

Reference nameplate on unit

1.3 MANUFACTURER

TRONAIR, Inc.
 1 Air Cargo Pkwy East
 Swanton, Ohio 43558 USA

Telephone: (419) 866-6301 or 800-426-6301
 Fax: (419) 867-0634
 E-mail: sales@tronair.com
 Website: www.tronair.com

1.4 SPECIFICATIONS

Tank Capacity: 8 gallon
 Maximum Pressure: 500/5000 psig
 Fluid: MIL-PRF-5606/MIL-PRF-83282
 Filtration: 2 Micron
 Weight: 65 lbs

1.5 FEATURES

- 15 foot hoses
- Pressure gauge
- Shut-off valve for component testing
- 5,000 psi high/low pump provides high flow and high pressure capability
- 5,000 psi pressure gauge
- 4 way valve for testing double acting cylinder

2.0 PREPARATION FOR USE

The Fluid Service Unit is shipped fully assembled, and only the following steps are required to make the unit operational:

1. Apply appropriate fluid label on reservoir near fill opening (see Illustrated Parts List)
2. Service reservoir – fill reservoir with appropriate clean fluid.
3. Adjust handle height to suit.

Remove Air from System By:

1. Close manual pump release screw (lower right corner of pump base block).
2. Open shut-off valve (adjacent to pressure gauge).
3. Move pump handle to top of stroke.
4. Remove pipe plug located near top side of piston cylinder.
5. Lower handle until there is fluid filling (spilling out) the top cavity.
6. Re-install pipe plug.
7. Flow fluid by actuating manual pump.

3.0 TRAINING

3.1 TRAINING REQUIREMENTS

The employer of the operator is responsible for providing a training program sufficient for the safe operation of the unit.

3.2 TRAINING PROGRAM

The employer provided operator training program should cover safety procedures concerning use of the unit in and around the intended aircraft at the intended aircraft servicing location.

3.3 OPERATOR TRAINING

The operator training should provide the required training for safe operation of the unit.

NOTE: Maintenance and Trouble Shooting are to be performed by a skilled and trained technician.

4.0 OPERATION

4.1 FLUID SERVICE UNIT OPERATION

1. Securely attach hose(s) to the aircraft.
2. Close pump release screw.
3. Open shut-off valve.
4. Select output hose #1 or #2 by rotating handle pointer to selected hose.
5. Transfer hydraulic fluid by actuating the manual hydraulic pump.

When Service Has Been Completed:

1. Open pump release screw to relieve hydraulic pressure.
2. Disconnect hose(s) from aircraft.
3. Install hose end dust plug.

4.2 COMPONENT TESTING

A shut-off valve has been provided to assure no back flow of fluid and therefore is to be closed after the required pressure has built up in the system.

Pressure is relieved by opening this shut-off valve and pump release screw.

5.0 TROUBLE SHOOTING

PROBABLE CAUSE	CORRECTIVE ACTION
High pressure leaks (at joint, plugs or tubing)	Re-tighten or repair
Leaky discharge check valve	Pump rapidly to dislodge; Or repair pump
Leaky release valve	Tighten release valve
Leaky pump O-ring packing	Repair pump
Lack of oil	Refill reservoir check system for leaks
Sticking inlet check valve	Pump rapidly to dislodge; Or repair pump
Closed air vent	Open air vent

6.0 MAINTENANCE

6.1 REMOVING AND SERVICING PUMP

NOTE: If pump is found faulty, call the factory for replacement or replace seals as follows:

1. Review Appendix I: Hand Pump Parts List during the following procedure.
2. Clamp suction (push on) hose and remove hose from pump.
3. Uncouple fitting of hydraulic hose from pump.
4. Remove pump from unit.
5. Remove cotter pins from clevis pins.
6. Remove four (4) socket head cap screws.
7. Remove flanges.
8. Remove tube assembly (Item 39).
9. Replace O-rings and backup ring. (See Appendix I: for available kits.)
10. Re-assemble in reverse order.

6.2 FILTER MAINTENANCE

The main pressure has a replaceable element that is **not** cleanable. It is recommended that this filter be changed **annually**, or whenever a **reduced maximum flow** is noticed. Refer to the parts list for the correct filter element number.



7.0 PROVISION OF SPARES

7.1 SOURCE OF SPARE PARTS

Spare parts may be obtained from the manufacturer:

TRONAIR, Inc.
 1 Air Cargo Pkwy East
 Swanton, Ohio 43558 USA

Telephone: (419) 866-6301 or 800-426-6301

Fax: (419) 867-0634

E-mail: sales@tronair.com

Website: www.tronair.com

7.2 RECOMMENDED SPARE PARTS LISTS

Reference the following page(s) for Replacement Parts and Kits available.

8.0 IN SERVICE SUPPORT

Contact Tronair, Inc. for technical services and information. See Section 1.3 – Manufacturer.

9.0 GUARANTEES/LIMITATION OF LIABILITY

Tronair products are warranted to be free of manufacturing or material defects for a period of one year after shipment to the original customer. This is solely limited to the repair or replacement of defective components. This warranty does not cover the following items:

- a) Parts required for normal maintenance
- b) Parts covered by a component manufacturers warranty
- c) Replacement parts have a 90-day warranty from date of shipment

If you have a problem that may require service, contact Tronair immediately. Do not attempt to repair or disassemble a product without first contacting Tronair, any action may affect warranty coverage. When you contact Tronair be prepared to provide the following information:

- a) Product Model Number
- b) Product Serial Number
- c) Description of the problem

If warranty coverage is approved, either replacement parts will be sent or the product will have to be returned to Tronair for repairs. If the product is to be returned, a Return Material Authorization (RMA) number will be issued for reference purposes on any shipping documents. Failure to obtain a RMA in advance of returning an item will result in a service fee. A decision on the extent of warranty coverage on returned products is reserved pending inspection at Tronair. Any shipments to Tronair must be shipped freight prepaid. Freight costs on shipments to customers will be paid by Tronair on any warranty claims only. Any unauthorized modification of the Tronair products or use of the Tronair products in violation of cautions and warnings in any manual (including updates) or safety bulletins published or delivered by Tronair will immediately void any warranty, express or implied.

The obligations of Tronair expressly stated herein are in lieu of all other warranties or conditions expressed or implied. **Any unauthorized modification of the Tronair products or use of the Tronair products in violations of cautions and warnings in any manual (including updates) or safety bulletins published or delivered by Tronair will immediately void any warranty, express or implied and Tronair disclaims any and all liability for injury (WITHOUT LIMITATION and including DEATH), loss or damage arising from or relating to such misuse.**

10.0 APPENDICES

APPENDIX I Instrument Certification Notice

APPENDIX II Declaration of Conformity

Parts List

When ordering replacement parts/kits, please specify model, serial number and color of your unit.

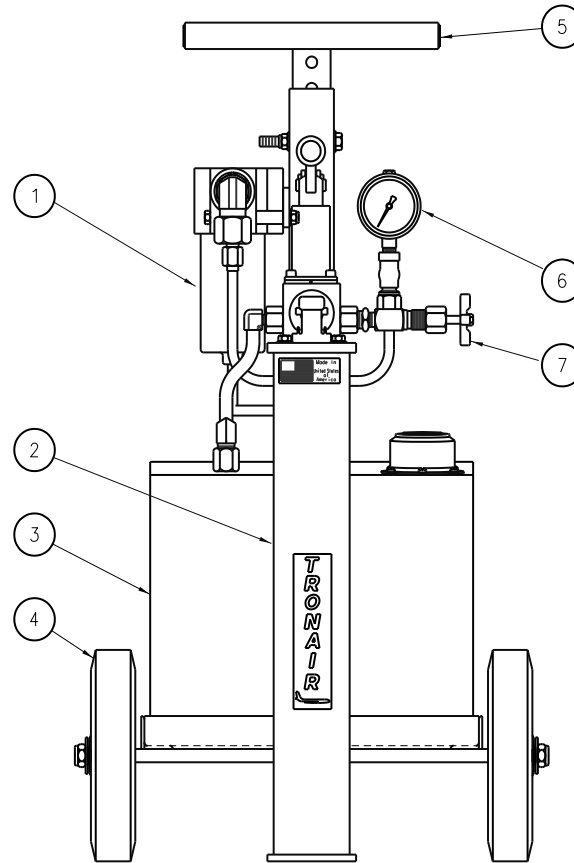

Item	Part Number	Description	Qty
1	HC-1083	Assembly, Pressure Filter	1
2	Z-1201-01	Frame	1
3	H-1802	Tank	1
4	U-1001-01	Wheel	2
5	Z-1083-01	Handle, Unit	1
6	HC-1042	Gauge, Pressure	1
7	HC-1101-01	Valve, Shut-Off	1

Parts List

When ordering replacement parts/kits, please specify model, serial number and color of your unit.

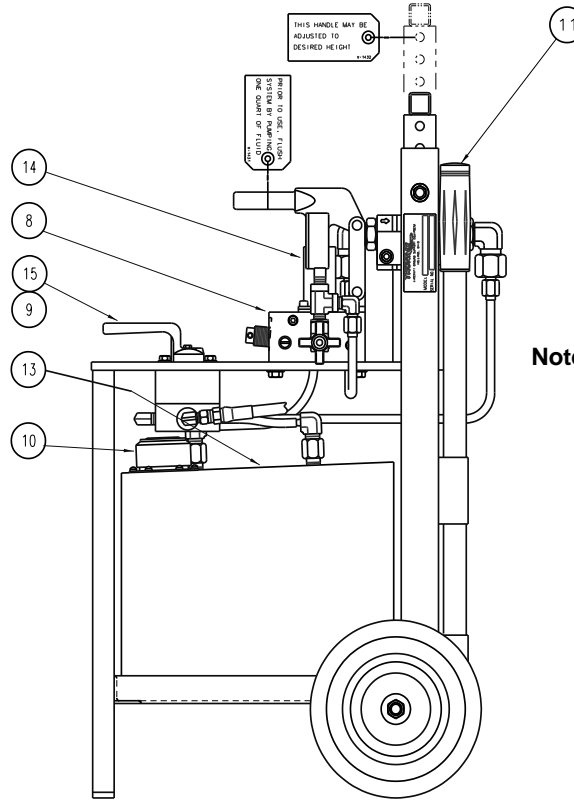

Item	Part Number	Description	Qty
8	HC-2765	Pump, Hand	1
9	HC-1044-01	Valve, Selector	1
10	HC-1030	Breather	1
11	H-1009-01	Handle, Pump	1
13	V-2051-01 or V-1035	Label - Fluid Type	1
14	TF-1047-01*10.0	Hose, Pump Suction	1
15	TF-1047-01*03.5	Hose, Valve Return	1
Not Shown	TF-1043-01*180	Assembly, Hose	1

Parts List Pressure Filter (4 inch) Assembly

When ordering Replacement Parts/Kits, please specify Model and Serial Number of your Unit.

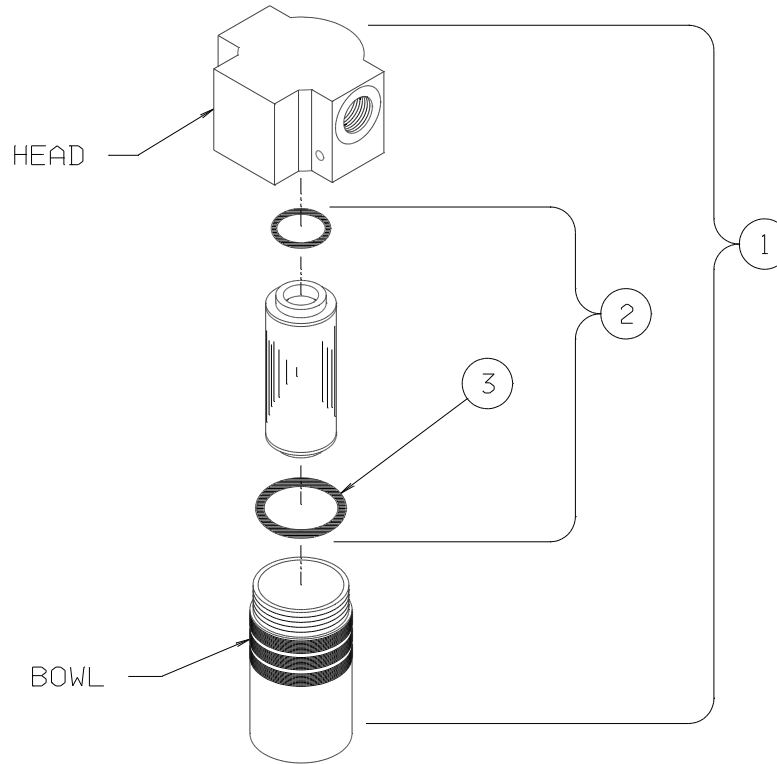

Item	Part Number	Description	Qty
1	HC-1083	Assembly, Filter	1
2	K-1414	Element, Filter	1
	HC-2000-136	O-Ring, Series 2	1
	HC-2000-138	O-Ring, Bowl	1

Parts List Shut-Off Valve

When ordering Replacement Parts/Kits, please specify Model and Serial Number of your Unit.

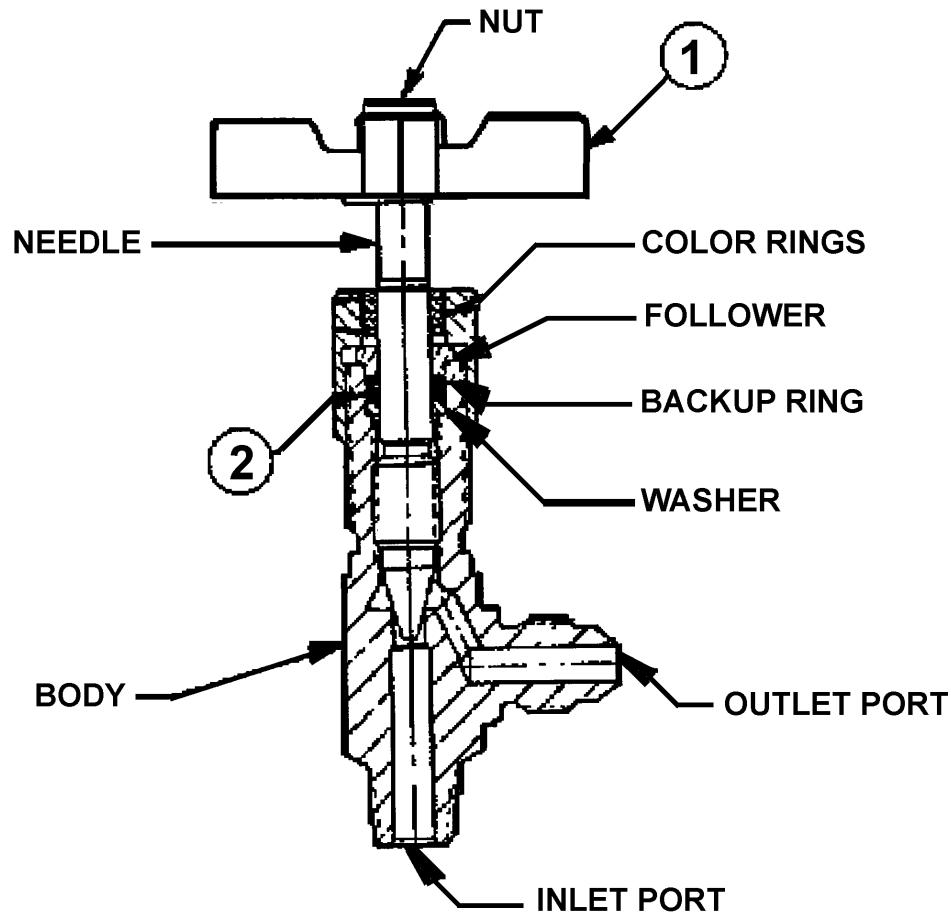

Item	Part Number	Description	Qty
	HC-1101-01	Assembly, Valve (Complete Component)	1
2	HC-1082	Handle, Valve	1
3	HC-2000-011	O-ring	1



APPENDIX I

Instrument Certification Notice



Instrument Certification Notice

The gauge Certificates of Calibration supplied for the gauge(s) on this unit contain the calibration data for the actual instrument calibrated, along with the calibration date of the **STANDARD** used to perform the calibration check.

The due date for re-calibration of the instrument should be based upon the date the instrument was placed in service in your facility. Re-calibration should be done on a periodic basis as dictated by the end user's quality system or other overriding requirements.

Note that Tronair, Inc. does not supply certificates of calibration on flow meters or pyrometers unless requested at the time of placed order. These instruments are considered reference indicators only and are not critical to the test(s) being performed on the aircraft.



APPENDIX II

Declaration of Conformity



DECLARATION of CONFORMITY

The design, development and manufacture is in accordance with European Community guidelines

06-5004C0500

Relevant provisions complied with by the machinery:
2006/42/EC

Identification of person empowered to sign on behalf of the Manufacturer:

A handwritten signature in cursive script that reads "Patrick Finch". The signature is written in black ink and is positioned above a solid horizontal line.

Quality Assurance Representative