

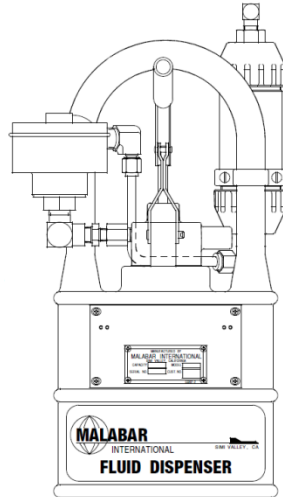

OPERATION & SERVICE MANUAL



Model: PF53361-2PWS 2 gal (7.6 l) Fluid Dispenser

11/2018 – Rev. 01

REVISION
01

DATE
11/2018

TEXT AFFECTED
Original release



TABLE OF CONTENTS

	<u>PAGE</u>
1.0 PRODUCT INFORMATION	4
1.1 DESCRIPTION.....	4
1.2 MODEL & SERIAL NUMBER.....	4
1.3 MANUFACTURER	4
1.4 SPECIFICATIONS	4
2.0 SAFETY INFORMATION.....	4
2.1 USAGE AND SAFETY INFORMATION	4
3.0 PREPARATION PRIOR TO FIRST USE	4
4.0 TRAINING	5
4.1 TRAINING REQUIREMENTS	5
4.2 TRAINING PROGRAM	5
4.3 OPERATOR TRAINING	5
5.0 OPERATION	5
6.0 MAINTENANCE	5
6.1 SERVICING	5
6.2 REPAIR AND REPLACEMENT	5
7.0 PROVISION OF SPARES.....	5
7.1 SOURCE OF SPARE PARTS.....	5
7.2 RECOMMENDED SPARE PARTS LISTS	5
8.0 IN SERVICE SUPPORT.....	5
9.0 GUARANTEES/LIMITATION OF LIABILITY	6

This product can not be modified without the written approval of Tronair, Inc. Any modifications done without written approval voids all warranties and releases Tronair, Inc., its suppliers, distributors, employees, or financial institutions from any liability from consequences that may occur. Only Tronair OEM replacement parts shall be used.

CAUTION!



Aircraft manufacturer's specifications and instructions must be followed. In the event of contradiction between aircraft manufacturer's specifications and Malabar's, aircraft manufacturer's will prevail.

1.0 PRODUCT INFORMATION

1.1 DESCRIPTION

The Malabar Model PF53361-2PWS is a 2 gallon fluid dispenser used to service various commercial aircraft. The hand pump dispenser consists of a reservoir, pump assembly, relief valve, water stop filter assembly, fluid meter and a fluid delivery hose with a coupling and gravity fill adapter assembly.

1.2 MODEL & SERIAL NUMBER

Reference nameplate on unit

1.3 MANUFACTURER

Malabar International
1 Air Cargo Pkwy East
Swanton, Ohio 43558 USA

Telephone: (419) 866-6301 or 800-426-6301
E-mail: sales@malabar.com
Website: www.malabar.com

1.4 SPECIFICATIONS

Fluid	Petroleum Based
Reservoir capacity	2 gal (7.6 l)
Pump outlet pressure	100 psig (689 kPa)
Volume per stroke	2.5 cubic in (41 cc)
Relief valve setting	125 ± 10 psig (862 ± 69 kPa)
Hose length	84 in (2134 mm)
Net weight (empty)	12 lbs (5.4 kg)
Filter rating	1 micron nominal
Fluid tank color	green

2.0 SAFETY INFORMATION

2.1 USAGE AND SAFETY INFORMATION

To insure safe operations please read the following statements and understand their meaning. Also refer to your equipment manufacturer's manual for other important safety information. This manual contains safety precautions which are explained below. Please read carefully.



WARNING!

Warning is used to indicate the presence of a hazard that can cause **severe personal injury, death, and/or substantial property damage** if the Warning Notice is ignored.



CAUTION!

Caution is used to indicate the presence of a hazard, which will or can cause **minor personal injury or property damage** if the Caution Notice is ignored.

3.0 PREPARATION PRIOR TO FIRST USE

The unit is shipped fully assembled. Fill reservoir at fillport with approved fluid. Operate hand pump assembly a few strokes to bleed all air out of the system. The unit is now ready for use.



4.0 TRAINING

4.1 TRAINING REQUIREMENTS

The employer of the operator is responsible for providing a training program sufficient for the safe operation of the unit.

4.2 TRAINING PROGRAM

The employer provided operator training program should cover safety procedures concerning use of the unit in and around the intended aircraft at the intended aircraft servicing location.

4.3 OPERATOR TRAINING

The operator training should provide the required training for safe operation of the unit.

NOTE: Maintenance and Trouble Shooting are to be performed by a skilled and trained technician.

5.0 OPERATION

1. Remove dust plug from hose coupling and connect the hose coupling to the aircraft service point or connect coupling to gravity fill adapter assembly.
2. Use full steady pumping strokes when operating pump assembly during replenishing.
3. Disconnect the hose coupling or gravity fill adapter assembly from the aircraft service point, replace the dust plug and store the unit in a dry, dust free location.

6.0 MAINTENANCE

6.1 SERVICING

The frequency of filter change depends on operating conditions. Generally, changes should be made every 3-4 months or sooner if more than normal resistance is felt on the pumping stroke at low pressure. Refer to item 10 in figure 3 to change element. Proper element must be installed, otherwise unit will not pump fluid.

NOTE: The relief valve should not be removed. The relief valve is set to pass oil back to the reservoir at 125 ± 10 PSIG.

6.2 REPAIR AND REPLACEMENT

No definite time schedule can be established for the overhaul of the pump assembly for the replacement of the various moving parts. The number of times the pump assembly is operated materially affect the life of the working parts. The moving piston seal (item 6) and rod seal (item 11) are normally the first to wear. This is usually indicated by leakage of fluid past the piston or rod. It is advisable to change piston seal (item 6), rod seal (item 11) and gasket (item 16) immediately if leakage is discovered. A repair parts kit (P/N PF2-41PK) is available and recommended to keep on hand at your facility. Refer to repair parts kit for the complete list of parts contained in the repair parts kit.

7.0 PROVISION OF SPARES

7.1 SOURCE OF SPARE PARTS

Spare parts may be obtained from the manufacturer:

Malabar International

1 Air Cargo Pkwy East

Swanton, Ohio 43558 USA

Telephone: (419) 866-6301 or 800-426-6301

E-mail: sales@malabar.com

Website: www.malabar.com

7.2 RECOMMENDED SPARE PARTS LISTS

Reference the following page(s) for Replacement Parts and Kits available.

Refer to figure 1A & 1B for unit assembly, figure 2 for pump assembly or figure 3 for filter assembly.

8.0 IN SERVICE SUPPORT

Contact Malabar, Inc. for technical services and information. See Section 1.3 – Manufacturer.



9.0 GUARANTEES/LIMITATION OF LIABILITY

- I. Seller warrants each new product of its manufacture to be free from defects in material or workmanship, under proper, reasonable, and normal use and service.
- II. The warranty period shall be as follows:
 - A. For Malabar equipment, with the exception of Tripod Jacks, the warranty period is one (1) year after date of shipment.
 - B. For Malabar Tripod Jacks, the warranty period is three (3) years after date of shipment.
- III. Where Buyer claims an alleged defect in material or workmanship and so advises Seller in writing within ten (10) days after discovery thereof, then and in such event, Buyer shall return said equipment, transportation prepaid, to the Seller, provided such return is timely and within the above-mentioned warranty period. This warranty and liability of the Seller is expressly limited solely to replacement or repair of defective parts or goods, and return at Buyer's expense to Buyer after finding by Seller the product was defective prior to original shipment or, at the option of Seller, to providing refund to Buyer of the purchase price for said product.
- IV. It is further expressly understood and agreed that:
 - A. THERE IS NO WARRANTY, REPRESENTATION OF CONDITION OF ANY KIND, EXPRESS OR IMPLIED, (INCLUDING NO WARRANTY OF MERCHANTABILITY OR OF FITNESS) EXCEPT THAT THE MATERIAL SHALL BE OF THE QUALITY SPECIFIED IN APPLICABLE SPECIFICATIONS, AND NONE SHALL BE IMPLIED BY LAW. Except as otherwise provided herein, quality shall be in accordance with Seller's specifications. Final determination of the material for the use contemplated by Buyer is the sole responsibility of Buyer and Seller shall have no responsibility in connection with such suitability, and
 - B. Buyer's sole and exclusive remedy shall be repair or replacement of defective parts or goods by the Seller. Should the goods, in the judgment of Seller, preclude the remedying of the warranted defects by repair or replacement, the Buyer's sole and exclusive remedy shall be the refund of the purchase price, and
 - C. Seller shall not be liable for prospective profits or special, indirect or consequential damages, nor shall any recovery of any kind against Seller be greater in amount than the purchase price of the specific material sold and causing the alleged loss, damage or injury. Buyer assumes all risk and liability for loss, damage or injury to persons or property of Buyer or others arising out of use or possession of any product or part sold hereunder, and
 - D. Seller shall in no way be deemed or held to be obligated, liable or accountable upon or for any guarantees or warranties, express or implied, or created by statute or by operation of law or otherwise, in any manner of form beyond its express agreement above set forth, and
 - E. No warranty herein shall apply to any product which shall have been repaired or altered, unless such alteration or repair has been made by Seller or if, after return to and inspection by Seller, the product is found by Seller to have been subject to misuse, negligence or accident, and
 - F. No warranty of any nature is made by Seller as to any component forming a part of the product sold and Buyer shall receive only such warranties offered by such other manufacturer of such component, and
 - G. Seller does not assume nor does Seller authorize any other person to assume for it any other liability or make any warranty in connection with the sale of its products.

Parts List – Figure 1A

When ordering replacement parts/kits, please specify model, serial number and color of your unit.

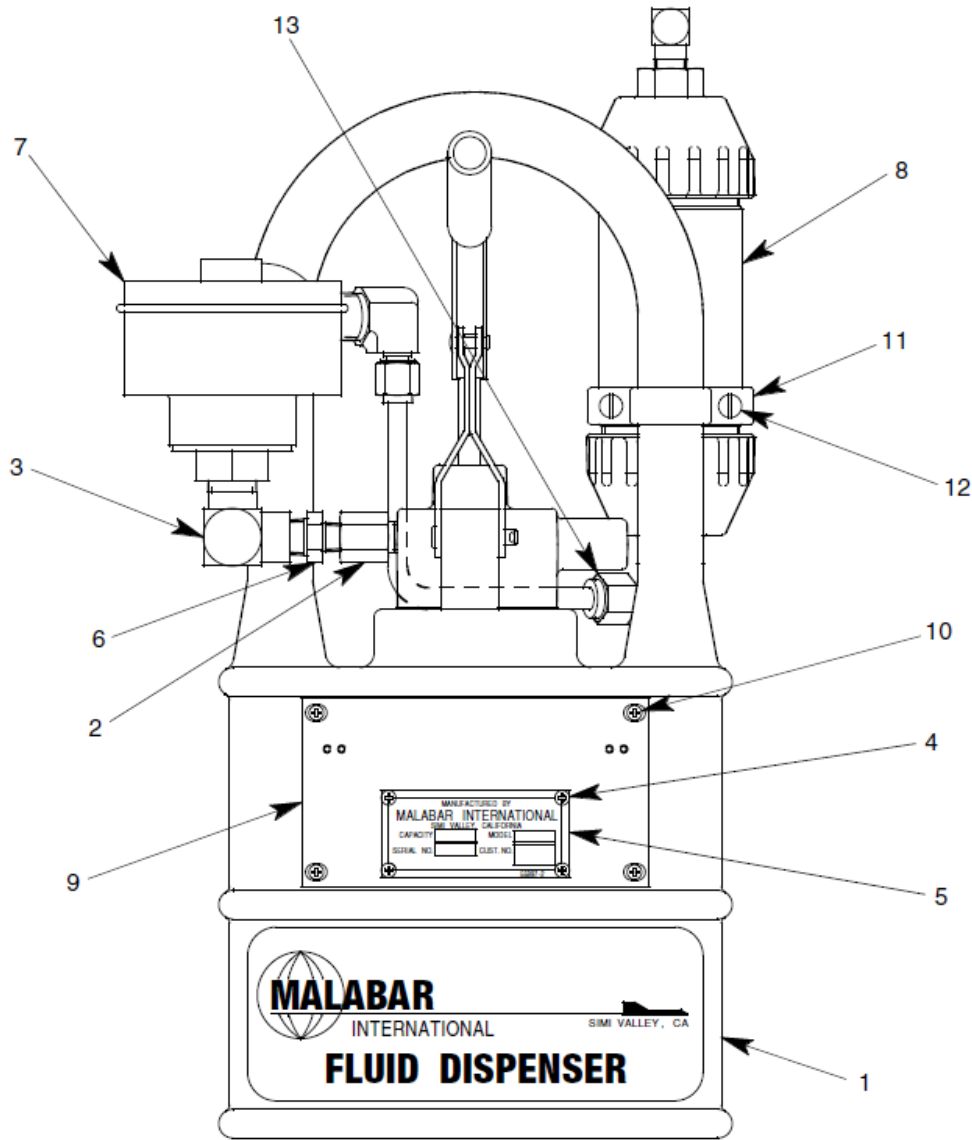

Item	Part Number	Description	Qty
1	PF55838-3	FLUID TANK	1
2	714-017	BUSHING, 1/4 NPT	1
3	712-032	ELBOW, 1/2 NPT X 3/8 NPT	1
4	397-010	SELF TAPPING SCREW, 6-32	6
5	55997-2	NAMEPLATE	1
6	711-018	REDUCER, 3/8 NPT X 1/4 NPT	1
7	486-024	FLUID METER	1
8	PF55873	FILTER ASSEMBLY	1
9	PF55859	PLACARD PLATE	1
10	344-011	FHMS, 6-32 x 7/16 LG	4
11	PF55871-1	YOKE CLAMP	1
12	342-010	SCREW, FIL HD, 1/4-20 X 1" LG	3
13	722-005	ELBOW, 3/8 37° x 1/4 NPT	1

Parts List – Figure 1B

When ordering replacement parts/kits, please specify model, serial number and color of your unit.

◆ PART OF REPAIR PARTS KIT

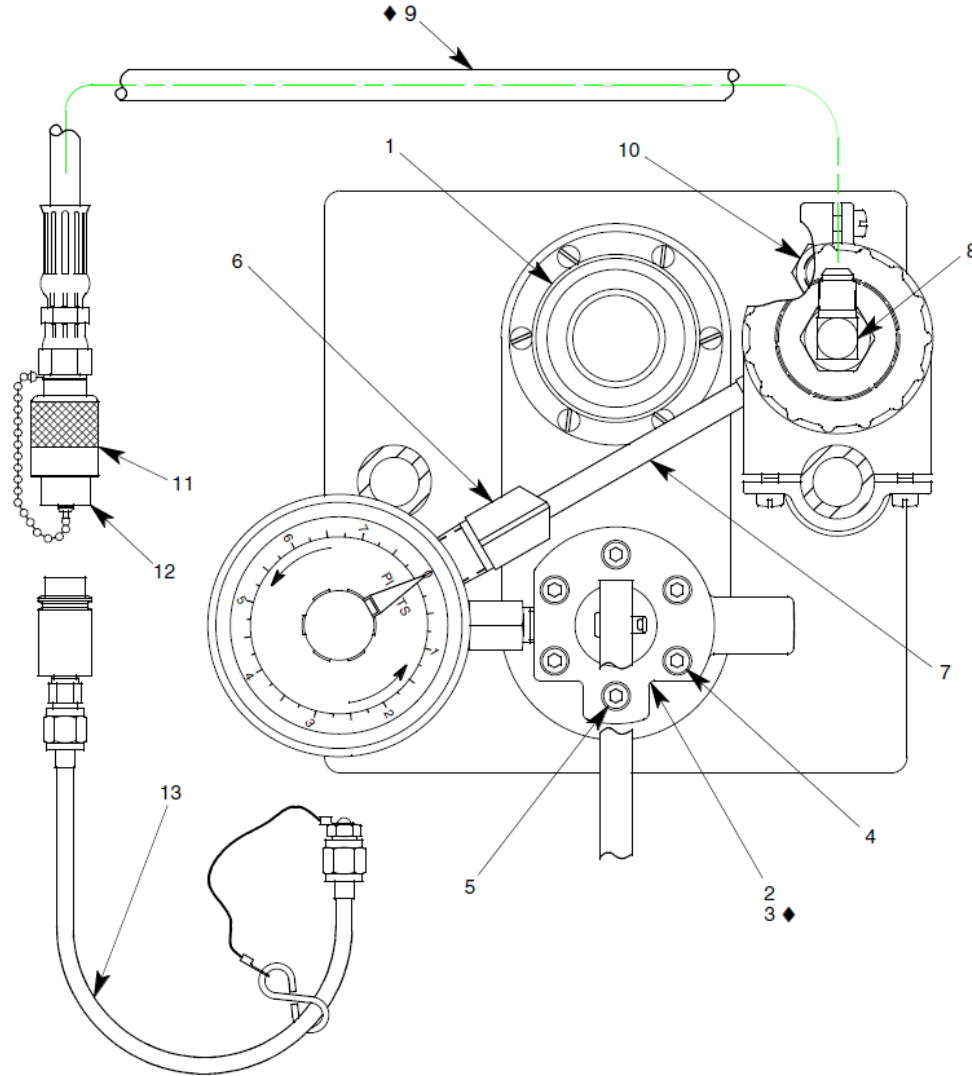

Item	Part Number	Description	Qty
1	PF55447	FILLPORT ASSEMBLY	1
2	PF55845-1	PUMP ASSEMBLY	1
3	PF55672	GASKET	1
4	323-038	SHCS, 1/4-28 x 1 3/4 LG	5
5	323-063	SHCS, 1/4-28 x 1" LG	1
6	722-015	ELBOW, 3/8 TUBE X 1/2 NPT	1
7	732-010	TUBING, 3/8 OD X .065 WALL	AR
8	722-005	ELBOW, 3/8 37° X 1/4 NPT	1
9	PF55456-1	HOSE ASSEMBLY	1
10	717-007	PLUG, 3/8 NPT	1
11	736-013	COUPLING	1
12	PF55987	DUST PLUG & CHAIN	1
13	PF55759	GRAVITY FILL ADAPTER	1



This page left blank intentionally.

Parts List – Figure 2

When ordering replacement parts/kits, please specify model, serial number and color of your unit.

Item	Part Number	Description	Qty
	PF55845-1	PUMP ASSEMBLY ; <i>consists of:</i>	
1	PF53376	TUBE ASSEMBLY	1
2	412-004	STEEL BALL, 1/4 DIA	1
3	717-006	PLUG, 1/4 NPT	1
4	PF53379	PISTON	1
5	PF53380	PISTON CHECK DISC	1
6	55925-216	O-RING	1
7	PF53378	PUMP PISTON ROD	1
8	352-011	HEX JAM NUT, 1/4-28	1
9	PF53406	SPRING	1
10	PF55820-1	PUMP OUTLET	1
11	55925-110	O-RING	1
12	373-006	FH PIN, 1/4 DIA x 1 9/32 LG	1
13	494-017	HANDLE ASSEMBLY	1
14	AN393-17	FH PIN, 3/16 DIA x 17/32 LG	1
15	372-011	COTTER PIN, 1/16 x 1/2 LG	2
16	PF54063	GASKET	1
17	55153	SPRING GUIDE	1
18	55148	SET SCREW	1
19	495-038	SPRING	1

Parts List – Figure 3

When ordering replacement parts/kits, please specify model, serial number and color of your unit.

◆ PART OF REPAIR PARTS KIT

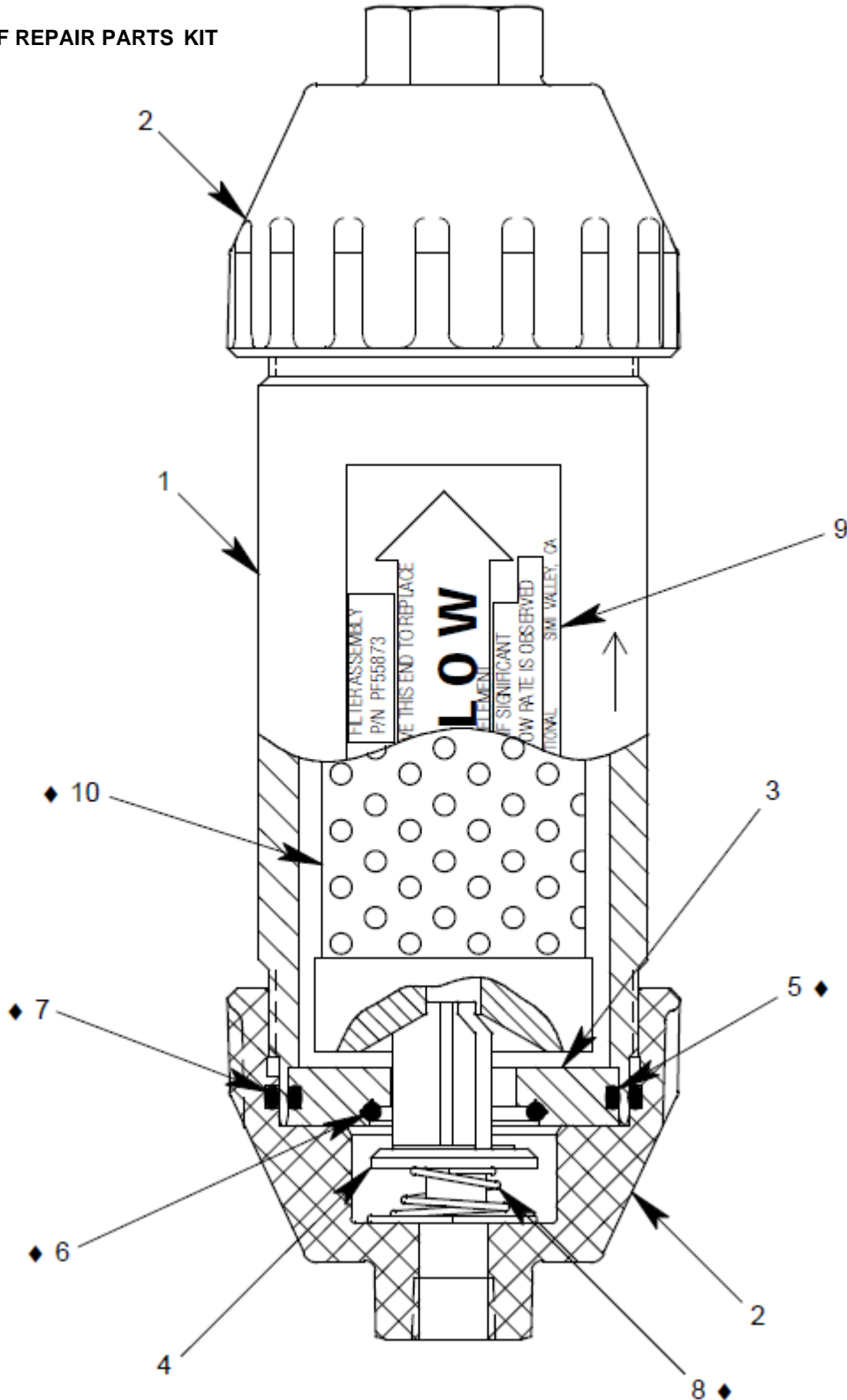

Parts List – Figure 3

When ordering replacement parts/kits, please specify model, serial number and color of your unit.

Item	Part Number	Description	Qty
	PF55873	PUMP ASSEMBLY ; <i>consists of:</i>	
1	PF55849	FILTER HOUSING	1
2	PF55852	FILTER HOUSING	2
3	PF55853	RETAINER DISC	1
4	PF55850	RETAINER VALVE	1
5	55925-135	O-RING	1
6	55925-120	O-RING	1
7	55925-140	O-RING	2
8	495-039	SPRING	1
9	PF55872	DECAL, FLOW	1
10	481-068	FILTER ELEMENT	1



Parts List – PF2-41PK Repair Parts Kit

When ordering replacement parts/kits, please specify model, serial number and color of your unit.

Part Number	Description	Qty
PF55456-1	HOSE ASSEMBLY	1
55925-216	O-RING	1
55925-110	O-RING	1
PF53406	SPRING	1
373-006	FLAT HEAD PIN, 1/4 DIA x 1 9/32 LG	1
372-011	COTTER PIN, 1/16 x 1/2 LG	2
AN393-17	FLAT HEAD PIN, 3/16 DIA x 17/32 LG	1
PF54063	GASKET	1
495-038	SPRING	1
412-004	STEEL BALL, 1/4 DIA	1
55925-135	O-RING	1
55925-120	O-RING	1
55925-140	O-RING	2
495-039	SPRING	1
481-068	FILTER ELEMENT	1
352-011	HEX JAM NUT, 1/4-28	1
PF55672	GASKET	1
PF2-41PKDOC	REPAIR PARTS KIT LIST	1