



## OPERATION & SERVICE MANUAL



**Model: 150-1**  
**1 qt (.95 l) O-C Fluid**  
**Gun Dispenser**

10/2018 – Rev. 01

REVISION  
01

DATE  
10/2018

TEXT AFFECTED  
Original release



**TABLE OF CONTENTS**

**PAGE**

<b>1.0</b>	<b>PRODUCT INFORMATION .....</b>	<b>4</b>
1.1	DESCRIPTION.....	4
1.2	MODEL & SERIAL NUMBER.....	4
1.3	MANUFACTURER .....	4
1.4	SPECIFICATIONS .....	4
<b>2.0</b>	<b>SAFETY INFORMATION.....</b>	<b>4</b>
2.1	USAGE AND SAFETY INFORMATION .....	4
<b>3.0</b>	<b>PREPARATION PRIOR TO FIRST USE .....</b>	<b>4</b>
<b>4.0</b>	<b>TRAINING .....</b>	<b>5</b>
4.1	TRAINING REQUIREMENTS .....	5
4.2	TRAINING PROGRAM .....	5
4.3	OPERATOR TRAINING .....	5
<b>5.0</b>	<b>OPERATION .....</b>	<b>5</b>
<b>6.0</b>	<b>MAINTENANCE .....</b>	<b>5</b>
6.1	SERVICING .....	5
6.2	REPAIR AND REPLACEMENT .....	5
<b>7.0</b>	<b>PROVISION OF SPARES.....</b>	<b>6</b>
7.1	SOURCE OF SPARE PARTS.....	6
7.2	RECOMMENDED SPARE PARTS LISTS .....	6
<b>8.0</b>	<b>IN SERVICE SUPPORT.....</b>	<b>6</b>
<b>9.0</b>	<b>GUARANTEES/LIMITATION OF LIABILITY .....</b>	<b>6</b>

This product can not be modified without the written approval of Tronair, Inc. Any modifications done without written approval voids all warranties and releases Tronair, Inc., its suppliers, distributors, employees, or financial institutions from any liability from consequences that may occur. Only Tronair OEM replacement parts shall be used.



### CAUTION!

**Aircraft manufacturer's specifications and instructions must be followed. In the event of contradiction between aircraft manufacturer's specifications and Malabar's, aircraft manufacturer's will prevail.**

## 1.0 PRODUCT INFORMATION

### 1.1 DESCRIPTION

The Malabar Model 150-1 is a one quart original container fluid gun dispenser used to service various commercial aircraft. The O-C Fluid Gun Dispenser consists of a hand pump assembly, filter assembly and a fluid delivery hose with a coupling.

### 1.2 MODEL & SERIAL NUMBER

Reference nameplate on unit

### 1.3 MANUFACTURER

**Malabar International**  
1 Air Cargo Pkwy East  
Swanton, Ohio 43558 USA

Telephone: (419) 866-6301 or 800-426-6301  
E-mail: sales@malabar.com  
Website: www.malabar.com

### 1.4 SPECIFICATIONS

Fluid	BP 2380
Fluid Capacity	1 qt (.95 l)
Pump Outlet Pressure	80 psig (551 kg/sq cm)
Volume Per Stroke	2 cu in (33 cc)
Hose Length	74 in (1880 mm)
Net Weight (empty)	6.5 lbs (2.9 kg)
Filter Rating	3 micron nominal

## 2.0 SAFETY INFORMATION

### 2.1 USAGE AND SAFETY INFORMATION

To insure safe operations please read the following statements and understand their meaning. Also refer to your equipment manufacturer's manual for other important safety information. This manual contains safety precautions which are explained below. Please read carefully.



### WARNING!

Warning is used to indicate the presence of a hazard that can cause **severe personal injury, death, and/or substantial property damage** if the Warning Notice is ignored.



### CAUTION!

Caution is used to indicate the presence of a hazard, which will or can cause **minor personal injury or property damage** if the Caution Notice is ignored.

## 3.0 PREPARATION PRIOR TO FIRST USE

1. Attach the hose assembly to the gun. Avoid over tightening the swivel nut.
2. The two latches attached to the clamp bars may require adjustment. Loosen the four screws, washers and self-locking nuts and adjust latches to fit oil can before tightening screws.

## 4.0 TRAINING

### 4.1 TRAINING REQUIREMENTS

The employer of the operator is responsible for providing a training program sufficient for the safe operation of the unit.

### 4.2 TRAINING PROGRAM

The employer provided operator training program should cover safety procedures concerning use of the unit in and around the intended aircraft at the intended aircraft servicing location.

### 4.3 OPERATOR TRAINING

The operator training should provide the required training for safe operation of the unit.

**NOTE: Maintenance and Trouble Shooting are to be performed by a skilled and trained technician.**

## 5.0 OPERATION

- Slide piercer rod fully up and latch oil can to gun. Check the fluid specification and brand for compatibility with the aircraft system.
- Strike piercer handle firmly using palm of hand or rubber mallet to drive piercer through top of oil can. Assure piercer is firmly placed in oil can.



### CAUTION!

To prevent damage to the piercer rod or piercer handle, do not use any tool other than a rubber mallet.

- Open the bleed screw on the sight gage (one turn only) and carefully pump the gun to prime and eliminate any air bubbles. Close bleed screw.



### CAUTION!

Air pumped in with oil may cause false level readings in aircraft systems as the air eventually bubbles off and the level drops.

- Remove dust plug from hose end coupling and connect hose end coupling to the aircraft service point.
- Use full steady pump strokes when operating pump assembly during replenishing. Stop pumping oil when can is empty or air bubbles are detected in sight gage. Reprime gun when changing cans.
- When finished, disconnect the hose end coupling from the aircraft service point. Replace the dust plug and store the gun in a dry dust free location.
- When gun is stored, it is advisable to keep oil can latched to the gun to prevent contamination and oil mess.

## 6.0 MAINTENANCE

### 6.1 SERVICING

The frequency of filter change depends on operating conditions. Generally, changes should be made every 3-4 months or sooner if more than normal resistance is felt on the pumping stroke at low pressure. Refer to figure 1A, item 43 to change filter element.

### 6.2 REPAIR AND REPLACEMENT

No definite time schedule can be established for the overhaul of the O-C fluid gun dispenser assembly for the replacement of the various moving parts. The number of times the pump assembly is operated materially affects the life of the working parts. The moving piston seals (figure 1A, item 20) and piercer rod seals (figure 1A, item 22) are normally the first to wear. This is usually indicated by leakage of fluid past the piston rod (figure 1A, item 2) or the piercer rod (figure 1A, item 12). It is advisable to change piston seals (figure 1A, item 20) and piercer rod seals (figure 1A, item 22) immediately if leakage is discovered. Regardless of apparent condition, replace all parts marked with (◆). A repair parts kit (P/N 150-4PK) which contains all of the parts marked with (◆) is available and recommended to keep on hand at your facility. Coat all o-rings with petroleum jelly prior to assembly. Clean all metal parts with solvent and dry with compressed air. Lubricate all threads. Refer to sheet 6 for the complete list of parts contained in the repair parts kit.



## 7.0 PROVISION OF SPARES

### 7.1 SOURCE OF SPARE PARTS

Spare parts may be obtained from the manufacturer:

**Malabar International**

1 Air Cargo Pkwy East  
Swanton, Ohio 43558 USA

Telephone: (419) 866-6301 or 800-426-6301

E-mail: sales@malabar.com

Website: www.malabar.com

### 7.2 RECOMMENDED SPARE PARTS LISTS

Reference the following page(s) for Replacement Parts and Kits available.

## 8.0 IN SERVICE SUPPORT

Contact Malabar, Inc. for technical services and information. See Section 1.3 – Manufacturer.

## 9.0 GUARANTEES/LIMITATION OF LIABILITY

- I. Seller warrants each new product of its manufacture to be free from defects in material or workmanship, under proper, reasonable, and normal use and service.
- II. The warranty period shall be as follows:
  - A. For Malabar equipment, with the exception of Tripod Jacks, the warranty period is one (1) year after date of shipment.
  - B. For Malabar Tripod Jacks, the warranty period is three (3) years after date of shipment.
- III. Where Buyer claims an alleged defect in material or workmanship and so advises Seller in writing within ten (10) days after discovery thereof, then and in such event, Buyer shall return said equipment, transportation prepaid, to the Seller, provided such return is timely and within the above-mentioned warranty period. This warranty and liability of the Seller is expressly limited solely to replacement or repair of defective parts or goods, and return at Buyer's expense to Buyer after finding by Seller the product was defective prior to original shipment or, at the option of Seller, to providing refund to Buyer of the purchase price for said product.
- IV. It is further expressly understood and agreed that:
  - A. THERE IS NO WARRANTY, REPRESENTATION OF CONDITION OF ANY KIND, EXPRESS OR IMPLIED, (INCLUDING NO WARRANTY OF MERCHANTABILITY OR OF FITNESS) EXCEPT THAT THE MATERIAL SHALL BE OF THE QUALITY SPECIFIED IN APPLICABLE SPECIFICATIONS, AND NONE SHALL BE IMPLIED BY LAW. Except as otherwise provided herein, quality shall be in accordance with Seller's specifications. Final determination of the material for the use contemplated by Buyer is the sole responsibility of Buyer and Seller shall have no responsibility in connection with such suitability, and
  - B. Buyer's sole and exclusive remedy shall be repair or replacement of defective parts or goods by the Seller. Should the goods, in the judgment of Seller, preclude the remedying of the warranted defects by repair or replacement, the Buyer's sole and exclusive remedy shall be the refund of the purchase price, and
  - C. Seller shall not be liable for prospective profits or special, indirect or consequential damages, nor shall any recovery of any kind against Seller be greater in amount than the purchase price of the specific material sold and causing the alleged loss, damage or injury. Buyer assumes all risk and liability for loss, damage or injury to persons or property of Buyer or others arising out of use or possession of any product or part sold hereunder, and
  - D. Seller shall in no way be deemed or held to be obligated, liable or accountable upon or for any guarantees or warranties, express or implied, or created by statute or by operation of law or otherwise, in any manner of form beyond its express agreement above set forth, and
  - E. No warranty herein shall apply to any product which shall have been repaired or altered, unless such alteration or repair has been made by Seller or if, after return to and inspection by Seller, the product is found by Seller to have been subject to misuse, negligence or accident, and
  - F. No warranty of any nature is made by Seller as to any component forming a part of the product sold and Buyer shall receive only such warranties offered by such other manufacturer of such component, and
  - G. Seller does not assume nor does Seller authorize any other person to assume for it any other liability or make any warranty in connection with the sale of its products.



This page left blank intentionally

### Parts List – Figure 1A

When ordering replacement parts/kits, please specify model, serial number and color of your unit.

◆ PART OF REPAIR PARTS KIT

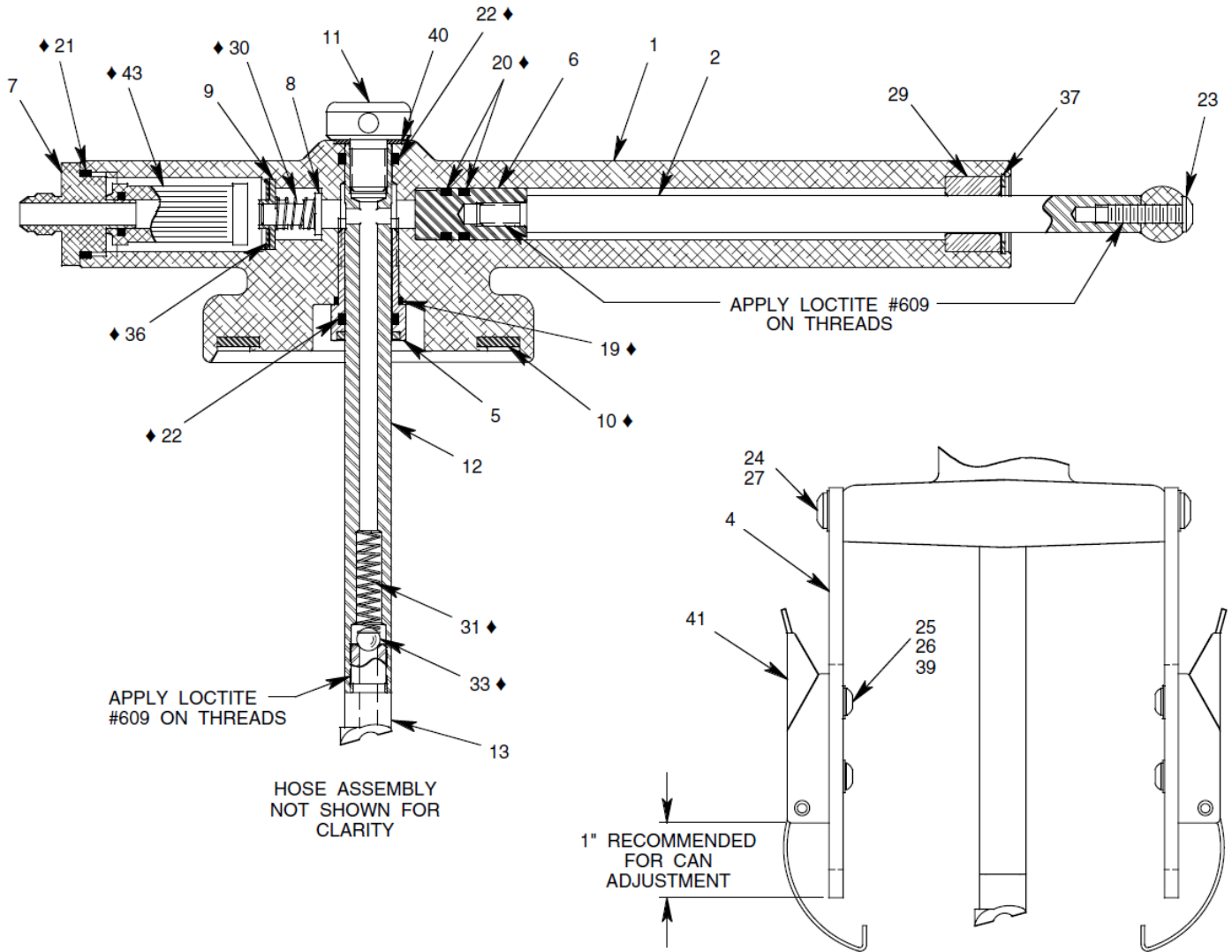



## Parts List – Figure 1A

When ordering replacement parts/kits, please specify model, serial number and color of your unit.

Item	Part Number	Description	Qty
1	*1744493-1	PUMP BODY MACHINE	1
2	1744405	PISTON ROD	1
4	1744407	CLAMP BAR	2
5	174459	BEARING BOLT ASSEMBLY	1
6	174411	PISTON	1
7	174412	ADAPTER FITTING	1
8	174413	VALVE POPPET	1
9	174414	POPPET GUIDE	1
10	174415	CAN SEAL	1
11	174416	PIERCER HANDLE	1
12	174460	PIERCER ROD	1
13	174461	PIERCER	1
19	55925-019	O-RING	1
20	55925-112	O-RING	2
21	55925-120	O-RING	1
22	55925-114	O-RING	2
23	326-009	BHCS, 1/4-20 x 1" LG	1
24	326-010	BHCS, 1/4-20 x 5/8 LG	4
25	326-020	BHCS, 10-24 x 1/2 LG	4
26	355-025	HEX LOCKNUT, 10-24	4
27	363-001	SPLIT LOCKWASHER, 1/4	4
29	410-017	BRONZE BEARING	1
30	495-035	SPRING	1
31	495-036	SPRING	1
33	412-002	BALL, CHROME, 5/16 DIA	1
36	380-004	RETAINING RING, PUSH ON	1
37	55926-100	RETAINING RING, PUSH ON	1
39	362-045	FLAT WASHER, #10	4
40	369-002	NYLON FLAT WASHER	1
41	491-056	LATCH	2
43	481-005	FILTER ELEMENT	1

\* NOTE: Pump body machine p/n 174493-1 replaces former pump body assembly p/n 174427, cover p/n 174462 and o-ring p/n 55925-123.

**Parts List – Figure 1B**

When ordering replacement parts/kits, please specify model, serial number and color of your unit.

◆ PART OF REPAIR PARTS KIT

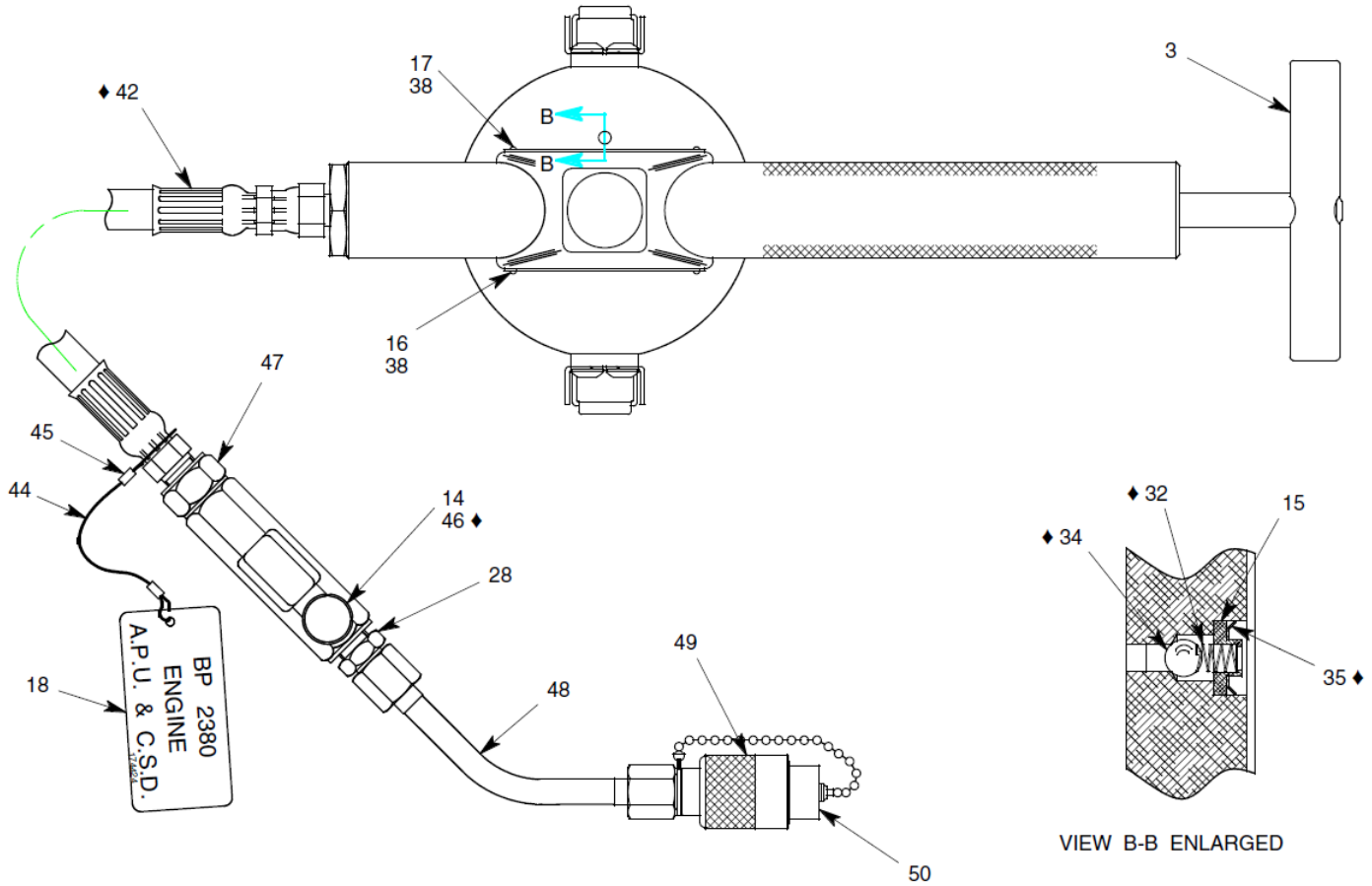

Item	Part Number	Description	Qty
3	1744406	HANDLE	1
14	174419	BLEED SCREW	1
15	174420	SPRING SUPPORT	1
16	174421	PLACARD	1
17	174422	PLACARD, BP 2380	1
18	174424	PLACARD, BP 2380	1
28	721-004	CONNECTOR, 3/8 37° x 1/4 MPT	1
32	495-037	SPRING	1
34	412-004	BALL, CHROME, 1/4 DIA	1
35	380-005	RETAINING RING, PUSH ON	1
38	393-004	DRIVE SCREW, #2 x 3/16 LG	8
42	174445	HOSE ASSEMBLY	1
44	491-027	CABLE, .048 DIA x 6" LG	1
45	491-028	SLEEVE CRIMP	2
46	55925-904	O-RING	1
47	174425	SIGHT GAGE	1
48	PF55817	FEMALE ELBOW ASSEMBLY	1
49	736-013	COUPLING	1
50	PF55987	DUST PLUG	1



### Parts List – 150-4PK Repair Parts Kit

When ordering replacement parts/kits, please specify model, serial number and color of your unit.

Part Number	Description	Qty
174445	HOSE ASSEMBLY	1
481-005	FILTER ELEMENT	1
174415	CAN SEAL	1
55925-904	O-RING	1
55925-114	O-RING	2
55925-120	O-RING	1
55925-112	O-RING	2
55925-019	O-RING	1
495-035	SPRING	1
495-036	SPRING	1
495-037	SPRING	1
412-002	BALL, CHROME, 5/16 DIA	1
412-004	BALL, CHROME, 1/4 DIA	1
380-005	RETAINING RING, PUSH ON	1
380-004	RETAINING RING, PUSH ON	1
150-4PKDOC	REPAIR PARTS KIT LIST	1