



OPERATION & SERVICE MANUAL



**Model: 06-4035-0500
Hydraulic Service Unit**

12/2002 – Rev. 14

TABLE OF CONTENTS

	<u>PAGE</u>
1.0 GENERAL DESCRIPTION	1
2.0 SPECIFICATIONS	1
3.0 FEATURES	1
4.0 PREPARATION FOR USE	1
5.0 OPERATION	1
5.1 USING HYDRAULIC SERVICE UNIT	1
5.2 COMPONENT TESTING	1
6.0 GUARANTEES/LIMITATION OF LIABILITY	2
7.0 APPENDICES	2

This product can not be modified without the written approval of Tronair, Inc. Any modifications done without written approval voids all warranties and releases Tronair, Inc., its suppliers, distributors, employees, or financial institutions from any liability from consequences that may occur. Only Tronair OEM replacement parts shall be used.

1.0 GENERAL DESCRIPTION

The Tronair 06-4035-0500 Hydraulic Service Unit is a compact unit designed to provide a source of clean, pressurized fluid for filling reservoirs, bleeding brakes and other maintenance functions.

2.0 SPECIFICATIONS

Tank Capacity:	8 gallons (30 liters)
Maximum Pressure:	500/4000 psig (34.5/276 bars)
Fluids:	MIL-PRF-5606/MIL-PRF-83282
Filtration:	2 Micron
Weight:	65 lbs (24.9 kg)

3.0 FEATURES

- 15 foot (4.6 m) hose
- Pressure gauge
- Shut-off valve for component testing
- 4000 psi (276 bars) hi-low pump provides high flow and high pressure capability

4.0 PREPARATION FOR USE

The HSU is shipped fully assembled and only the following steps are required to make the unit operational.

Service Reservoir:

1. Fill reservoir with appropriate clean fluid.
2. Adjust handle height to suit.

Remove Air from Hydraulic Service Unit System:

1. Close manual pump release screw. (Located at lower right corner of pump base block.)
2. Open shut-off valve. (Adjacent to pressure gauge.)
3. Move pump handle to top of stroke.
4. Remove pipe plug located near top side of piston cylinder.
5. Lower handle until there is fluid filling (spilling out) the top cavity.
6. Re-install pipe plug.
7. Flow fluid by actuating manual pump.

5.0 OPERATION

5.1 USING HYDRAULIC SERVICE UNIT

Follow the steps below:

1. Securely attach hose to the aircraft.
2. Close pump release screw.
3. Open shut-off valve.
4. Transfer hydraulic fluid by actuating the manual hydraulic pump.

When service has been completed:

1. Open pump release screw to relieve hydraulic pressure.
2. Disconnect hose from aircraft.
3. Install hose end dust plug.

5.2 COMPONENT TESTING

A shut-off valve has been provided to assure no back flow of fluid and therefore is to be closed after the required pressure has built up in the system.

Pressure is relieved by opening this shut-off valve and the pump release screw.

6.0 GUARANTEES/LIMITATION OF LIABILITY

Tronair products are warranted to be free of manufacturing or material defects for a period of one year after shipment to the original customer. This is solely limited to the repair or replacement of defective components. This warranty does not cover the following items:

- a) Parts required for normal maintenance
- b) Parts covered by a component manufacturers warranty
- c) Replacement parts have a 90-day warranty from date of shipment

If you have a problem that may require service, contact Tronair immediately. Do not attempt to repair or disassemble a product without first contacting Tronair, any action may affect warranty coverage. When you contact Tronair be prepared to provide the following information:

- a) Product Model Number
- b) Product Serial Number
- c) Description of the problem

If warranty coverage is approved, either replacement parts will be sent or the product will have to be returned to Tronair for repairs. If the product is to be returned, a Return Material Authorization (RMA) number will be issued for reference purposes on any shipping documents. Failure to obtain a RMA in advance of returning an item will result in a service fee. A decision on the extent of warranty coverage on returned products is reserved pending inspection at Tronair. Any shipments to Tronair must be shipped freight prepaid. Freight costs on shipments to customers will be paid by Tronair on any warranty claims only. Any unauthorized modification of the Tronair products or use of the Tronair products in violation of cautions and warnings in any manual (including updates) or safety bulletins published or delivered by Tronair will immediately void any warranty, express or implied.

The obligations of Tronair expressly stated herein are in lieu of all other warranties or conditions expressed or implied. **Any unauthorized modification of the Tronair products or use of the Tronair products in violations of cautions and warnings in any manual (including updates) or safety bulletins published or delivered by Tronair will immediately void any warranty, express or implied and Tronair disclaims any and all liability for injury (WITHOUT LIMITATION and including DEATH), loss or damage arising from or relating to such misuse.**

7.0 APPENDICES

- APPENDIX I HC-1034 Hand Pump (Mineral Base Fluids) Parts List
- APPENDIX II Instrument Certification Notice

Parts List
Hydraulic Service Unit

When ordering replacement parts/kits, please specify model, serial number and color of your unit.

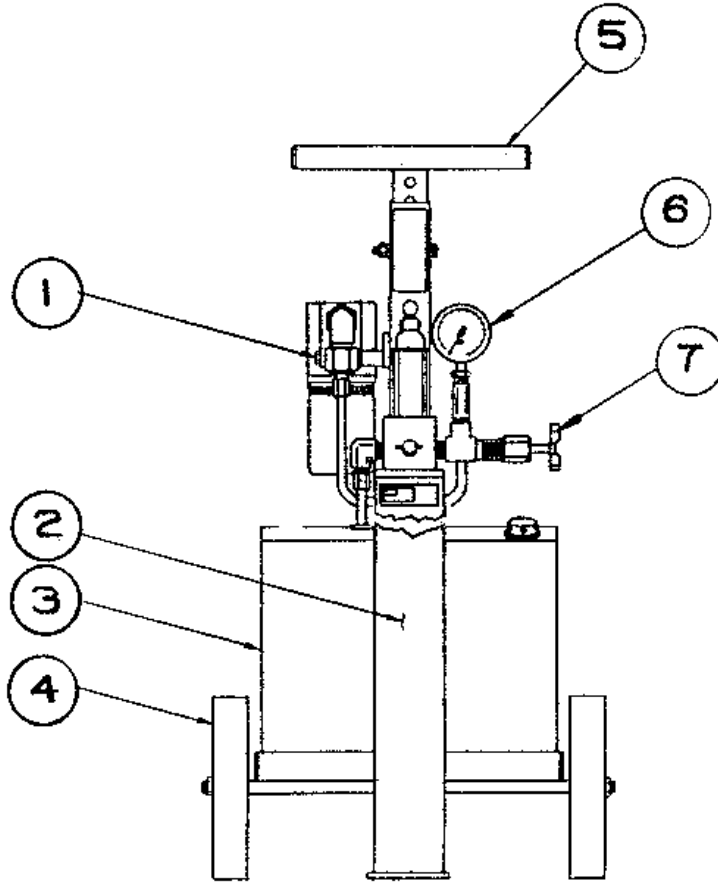

Note: Height not drawn to scale.

Item	Part Number	Description	Qty
1	HC-1083	Assembly, Pressure Filter	1
2	Z-1218-01	Frame	1
3	C-189	Tank	1
4	U-1001-01	Wheel	2
5	Z-1083-01	Handle, Unit	1
6	HC-1042	Gauge, Pressure	1
7	HC-1101-01	Valve, Shut Off (Mineral Base)	1

Parts List
Hydraulic Service Unit

When ordering replacement parts/kits, please specify model, serial number and color of your unit.

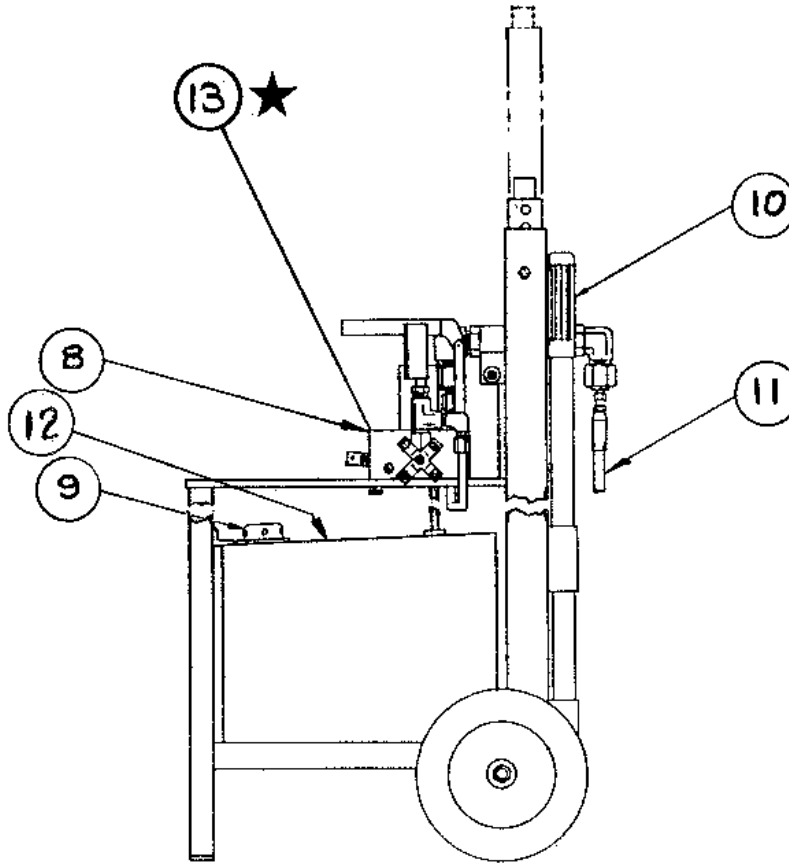

Note: Hose not shown (behind pump).

Item	Part Number	Description	Qty
9	HC-1030	Breather	1
10	H-1009-01	Handle, Pump	1
11	TF-1043-01*180	Assembly, Hose	1
12	V-1380	Label - Fluid Type	1
13	TF-1047-01*06.5	Hose, Pump Suction	1
8	K-2465-02	Kit, Pump Replacement; consists of:	
	HC-1034 (See Appendix I)	Pump, Two-Stage (Mineral Base)	1
	TF-1047-01*12.0	Hose, ¼ Gray	1
	INS-1334	Instruction, Pump Replacement	1

Parts List
HC-1083 Pressure Filter 4 inch (10.1 cm) Assembly

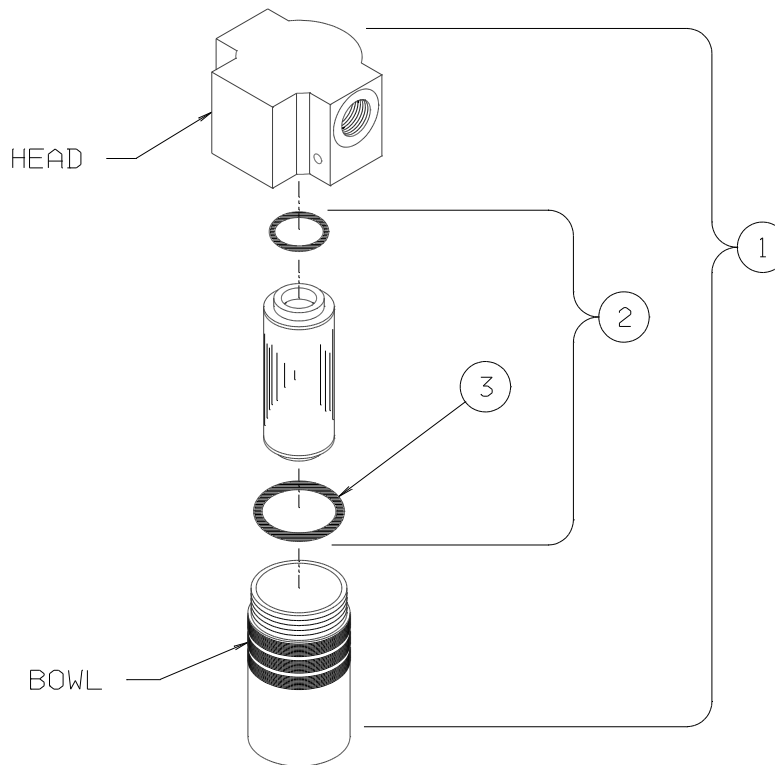

Item	Part Number	Description	Qty
1	HC-1083	Assembly, Filter (Mineral Base)	1
2	K-1414	Kit, Filter Element; consists of:	
	HC-1416	Element, Filter (Mineral Base)	1
	HC-2000-136	O-ring, Series 2	1
3	HC-2000-138	O-ring, Series 2	1

Parts List
HC-1101-01 Shut-Off Valve

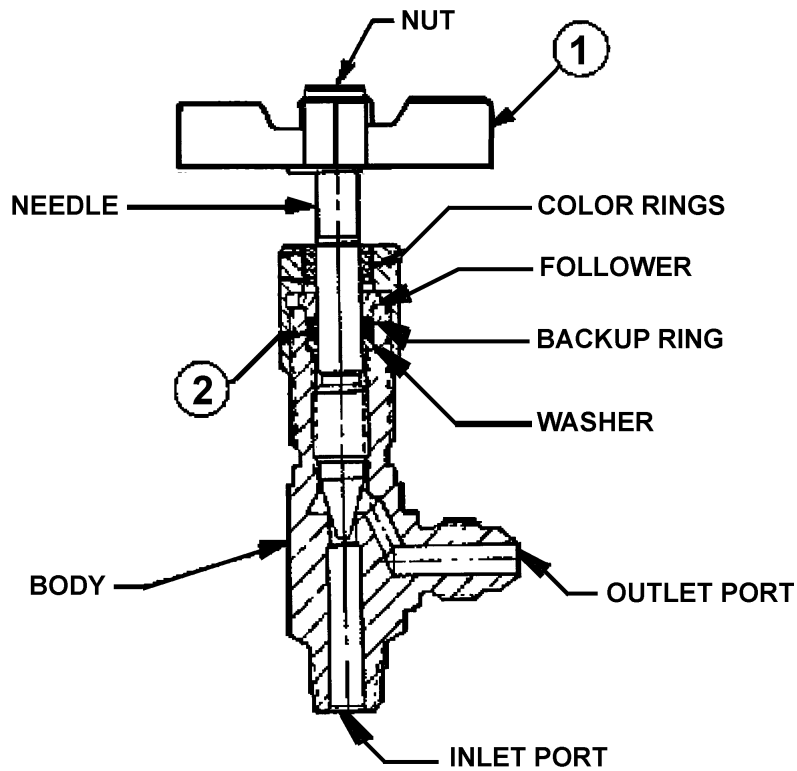

Item	Part Number	Description	Qty
	HC-1101-01	Assembly, Valve (Mineral Base) (Complete Component)	1
1	HC-1082	Handle, Valve	1
2	HC-2000-011	O-ring (Mineral Base)	1



APPENDIX I

HC-1034 Hand Pump Parts List



HC-1034 Hydraulic Hand Pump

Parts List With Illustrations

10/2004 – Rev. 03

When ordering Replacement Parts/Kits, please specify Model, Color and Serial Number of your Unit.

Parts List

This pump is compatible with MIL-PRF-5606/MIL-PRF-83282 Hydraulic Fluids.

Reference Parts List Illustration on following page

Item	Part Number	Description	Qty
1	501-000	Body, Pump	1
7	555-000	Bushing – 3/8 x 1/8 NPT	1
8	508-000	Pivot	1
9	510-001	Pin Assembly	2
10	509-000	Bracket - Pump Handle	1
11	H-1009-01	Handle	1
12	529-000	Handle Grip	1
13	512-000	Strap	2
27	505-000	Plug	3
28	577-120	Spring - Outlet Plug (L.P.)	1
29	571-120	Piston - Bypass	1
30	560-120	Valve Body	1
31	569-120	Ball - Bypass	1
32	564-120	Retainer Plate	1
33	562-125	Piston - High Pressure	1
34	561-125	Piston - Low Pressure	1
35	531-000	Clevis Pin	1
36	532-000	Cotter Pin	1
37	568-120	Tie Rod	4
38	582-120	Flange	4
39	563-120	Tube - Low Pressure	1
40	583-120	Plug – 5/16 NPT	1
	K-1029	Pump Valve Rebuilt Kit; consists of:	1
6		O-ring - Release Screw	6
14		O-ring - Output Check	14
15		O-ring - Inlet Check	15
16		O-ring - Valve Body	16
17		O-ring - Piston Seal	17
18		Packing - Piston	18
19		O-ring - Guide Shoe	19
26		Piston Guide Shoe	26
	K-1095	Pump Check Valve Hard Part Kit; consists of:	1
◆ 4		Release Ball	◆ 4
20		Spring - Output Check	20
21		Ball - Output Check	21
22		Spring - Inlet Check	22
23		Ball - Inlet Check	23
24		Spring - Bypass	24
25		Spring - Intake (L.P.)	25
	K-1984	Relief Valve Rebuilt Kit; consists of:	1
2		Screw Retainer	
3		Release Screw	
◆ 4		Release Ball	
5		Drive Pin	

NOTE: 1) Items designated as kits contain all hardware necessary for installation.
2) Unless otherwise listed, all replacement bolts should be Grade 5 or better.

◆ Items that are in more than one kit

Parts List Illustration

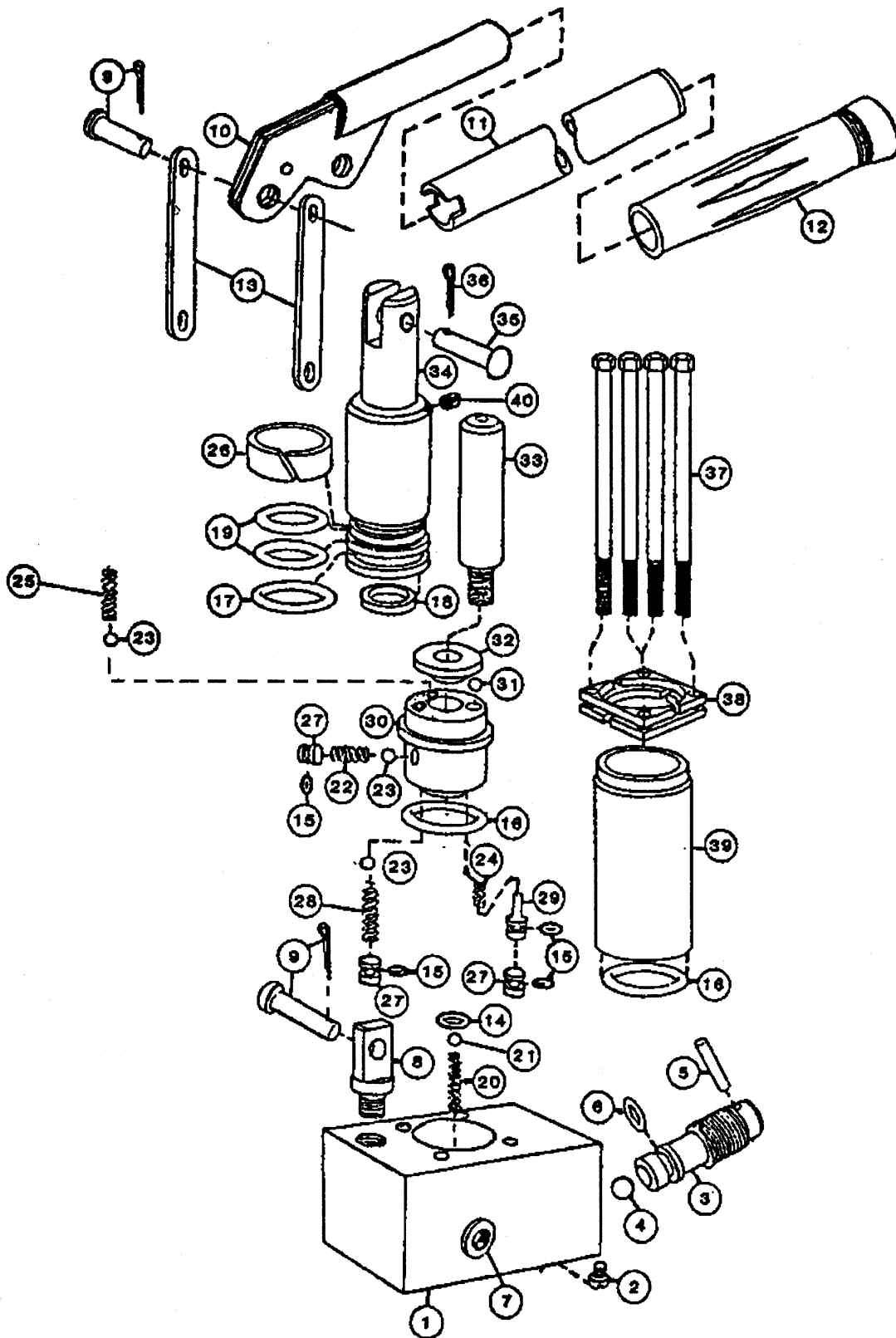



APPENDIX II

Instrument Certification Notice



Instrument Certification Notice

The gauge Certificates of Calibration supplied for the gauge(s) on this unit contain the calibration data for the actual instrument calibrated, along with the calibration date of the **STANDARD** used to perform the calibration check.

The due date for re-calibration of the instrument should be based upon the date the instrument was placed in service in your facility. Re-calibration should be done on a periodic basis as dictated by the end user's quality system or other overriding requirements.

Note that Tronair, Inc. does not supply certificates of calibration on flow meters or pyrometers unless requested at the time of placed order. These instruments are considered reference indicators only and are not critical to the test(s) being performed on the aircraft.