

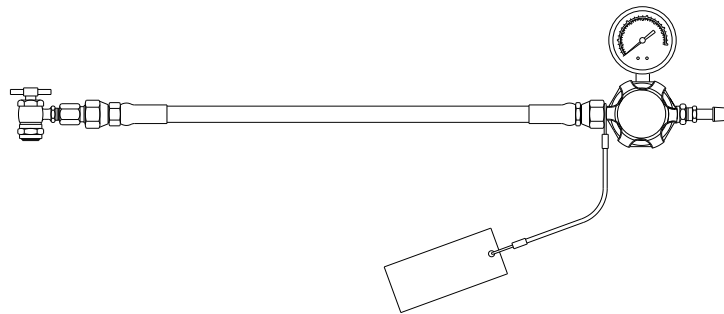

OPERATION & SERVICE MANUAL



**Model: 18-4216-6000
Low Pressure
Nitrogen Regulator**

09/2023 – Rev. 05

REVISION	DATE	TEXT AFFECTED
03	05/2010	Major revision
04	08/2021	Major revision
05	09/2023	Major revision

TABLE OF CONTENTS

	<u>PAGE</u>
1.0 PRODUCT INFORMATION	1
1.1 DESCRIPTION.....	1
1.2 MODEL & SERIAL NUMBER.....	1
1.3 MANUFACTURER.....	1
2.0 SAFETY INSTRUCTIONS	1
2.1 GENERAL.....	1
2.2 SAFETY.....	1
2.3 GENERAL SAFETY REQUIREMENTS.....	1
3.0 TRAINING.....	2
3.1 TRAINING REQUIREMENTS.....	2
3.2 TRAINING PROGRAM.....	2
3.3 OPERATOR TRAINING.....	2
4.0 OPERATION OF LOW PRESSURE NITROGEN REGULATOR.....	2
4.1 TRAINING.....	2
5.0 NUMERICAL VALUES	2
5.1 PRESSURE GAUGE.....	2
5.2 PRESSURE REGULATOR.....	2
5.3 OUTLET CONNECTON.....	2
5.4 INLET CONNECTON.....	2
5.5 TOOL BOX.....	2
6.0 USAGE INSTRUCTIONS.....	3
6.1 ASSEMBLY.....	3
6.2 DISASSEMBLY.....	3
7.0 MAINTENANCE.....	4
7.0 PROVISION OF SPARES.....	4
7.1 SOURCE OF SPARE PARTS.....	4
7.2 RECOMMENDED SPARE PARTS LISTS.....	4
8.0 GUARANTEES/LIMITATION OF LIABILITY.....	4

This product can not be modified without the written approval of Tronair, Inc. Any modifications done without written approval voids all warranties and releases Tronair, Inc., its suppliers, distributors, employees, or financial institutions from any liability from consequences that may occur. Only Tronair OEM replacement parts shall be used.

1.0 PRODUCT INFORMATION

1.1 DESCRIPTION

The Tronair 18-4216-6000 is a completely portable, self-contained, low pressure nitrogen regulator used for servicing of high frequency coupler antenna.

The unit is completely assembled and shipped in a plastic tool box. A male tire inlet valve allows connection to high pressure hose coupling. Low pressure regulator is attached to Ø ¼ x 16" long hose. Outlet connector allows mating to .305-32 male tire valve and contains a valve core depressor.

1.2 MODEL & SERIAL NUMBER

Reference nameplate on unit

1.3 MANUFACTURER

TRONAIR, Inc.
1 Air Cargo Pkwy East
Swanton, Ohio 43558 USA

Telephone: (419) 866-6301 or 800-426-6301
Fax: (419) 867-0634
E-mail: sales@tronair.com
Website: www.tronair.com

2.0 SAFETY INSTRUCTIONS



CAUTION

It is **MANDATORY** that this instruction manual be read and understood by all persons operating this Low Pressure Nitrogen Regulator.

2.1 GENERAL

Information presented in this manual and on various labels, tags and plates on the unit pertains to equipment design, installation, operation, maintenance and trouble shooting which should be read, understood and followed for the safe and effective use of this equipment.

2.2 SAFETY

The Operation, Maintenance, and Trouble Shooting of this Low Pressure Nitrogen Regulator require practices and procedures which ensure personal operator safety and the safety of others. Therefore, this equipment is to be operated and maintained only by qualified persons in accordance with this manual and all applicable local codes.

NOTE: Safety instructions specifically pertaining to this regulator appear throughout this manual highlighted by the signal words: **WARNING, CAUTION, which identify different levels of hazard.**



WARNING!

Warning is used to indicate the presence of a hazard that can cause **severe personal injury, death, and/or substantial property damage** if the Warning Notice is ignored.



CAUTION!

Caution is used to indicate the presence of a hazard, which will or can cause **minor personal injury or property damage** if the Caution Notice is ignored.

2.3 GENERAL SAFETY REQUIREMENTS

Pressures: Gasses under pressure are a potential hazard in the form of stored energy. Accidents can occur when this energy is improperly handled. Be sure that all equipment used is compatible and designed to control the pressures encountered.

Nitrogen: Nitrogen is chemically stable, non-flammable, and does not support combustion.

Handling: Nitrogen handling must be done with care. The rapid expansion of Nitrogen gas from a high pressure source to an area of low pressure can produce cryogenic temperatures which could cause severe burns.



WARNINGS!

1. **DO NOT use on low pressure Nitrogen system or components.**
2. **If there are any differences between the following instructions and the aircraft maintenance manual, the aircraft maintenance manual will take precedence.**
3. **Be sure fill line is secured prior to purging the unit. This will prevent the nose end from whipping about if too much Nitrogen is allowed to flow through the unit.**



CAUTION!

Be sure all valves and controls are in the closed (Off) position.

3.0 TRAINING**3.1 TRAINING REQUIREMENTS**

The employer of the operator is responsible for providing a training program sufficient for the safe operation of the unit.

3.2 TRAINING PROGRAM

The employer provided operator training program should cover safety procedures concerning use of the unit in and around the intended aircraft at the intended aircraft servicing location.

3.3 OPERATOR TRAINING

The operator training should provide the required training for safe operation of the unit.

NOTE: Maintenance and Trouble Shooting are to be performed by a skilled and trained technician.

4.0 OPERATION OF LOW PRESSURE NITROGEN REGULATOR**WARNING**

TO AVOID SERIOUS INJURY, LOSS OF LIMB, AND/OR DEATH:

1. **DO NOT use high pressure Nitrogen on aircraft components designed for low pressure Nitrogen.**
2. **DO NOT use with Oxygen or gas other than Nitrogen.**
3. **DO NOT exceed 150 psi inlet pressure.**
4. **Servicing and Maintenance of Nitrogen Systems shall be done by only trained and qualified personnel using approved procedures.**

4.1 TRAINING

Read this entire manual prior to operation of the unit. All personnel using this Nitrogen Regulator should understand and follow this manual, as well as receive training. We encourage our customers to call Tronair at 800-426-6301 to discuss any operating or testing requirements.

Nitrogen equipment must be kept clean and free from contaminants at all times. It is imperative that all inspection, maintenance, testing and servicing of Nitrogen system components be done by trained and qualified personnel using approved procedures.

5.0 NUMERICAL VALUES**5.1 PRESSURE GAUGE**

Range..... 30 HG 0-30 psi
Graduation 1 psi increments
Accuracy $\pm 2 \frac{1}{2}$ % full scale

5.2 PRESSURE REGULATOR

High Purity Single Stage
Max Inlet Pressure 3,500 psi
Outlet Pressure 0 – 15 psi
Temperature Range -40° to 165° F

5.3 OUTLET CONNECTON

- .305-32 tire valve with valve core depressor

5.4 INLET CONNECTON

- .305-32 male tire valve with no valve core

5.5 TOOL BOX

- Black Plastic
- Dimensions: 18" L x 13" W x 6 ½" H

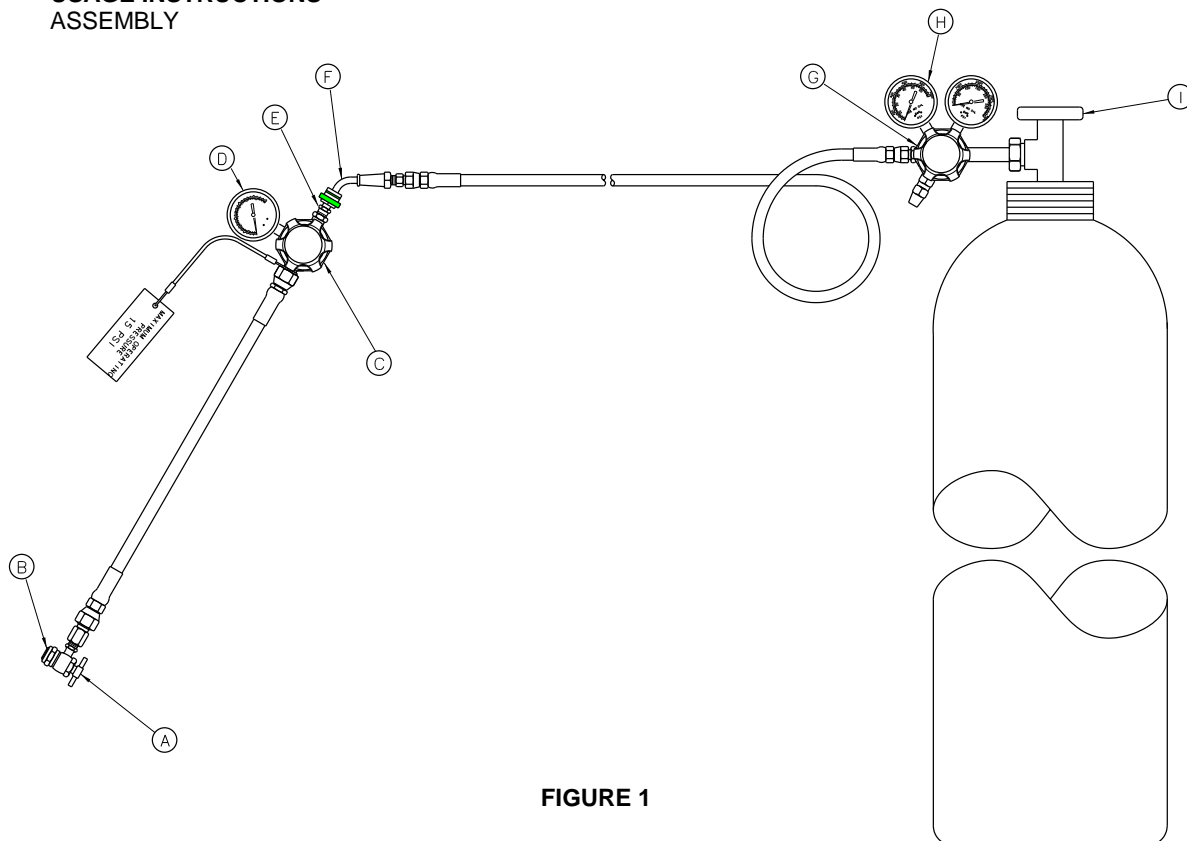
6.0 USAGE INSTRUCTIONS**6.1 ASSEMBLY****FIGURE 1**

NOTE: It is recommended Nitrogen servicing procedure be accomplished in conjunction with Tronair Service Regulator/Model: 14-6808-6000.

Reference **Figure 1** during the following steps:

1. Ensure (I) Nitrogen bottle supply valve is closed (Off).
2. Install (G) high pressure regulator to Nitrogen supply (not included).
3. Install (E) low pressure regulator to (F) high pressure regulator.
4. Ensure the high pressure regulator knob (G) is in closed position.

NOTE: The (G) regulator adjustment knob is a rotating type. Clockwise rotation of the knob increases pressure and counter-clockwise rotation decreases pressure.

5. Ensure the low pressure regulator knob (C) is in closed position.
6. Open the nitrogen bottle supply valve (I).
7. Turn the high pressure regulator knob (G) to adjust pressure to 100 psi (± 25 psi). Monitor the pressure on gauge (H).
8. Connect (B) connector to high frequency antenna service port.
9. Turn low pressure connector (A) t-handle clockwise to depress the stem on the HF antenna valve.
10. Turn the low pressure regulator knob (C) to adjust to aircraft manufacturers recommended service level.
11. Once pressure is reached, turn t-handle counterclockwise to hold pressure. Repeat as necessary.

6.2 DISASSEMBLY

1. Back (A) valve core depressor off.
2. Close (I) Nitrogen supply valve.
3. Disconnect (B) valve core depressor from high frequency antenna service port.
4. Disconnect (E) low pressure regulator from (F) high pressure regulator.
5. Disconnect (G) high pressure regulator from (I) Nitrogen supply bottle.

7.0 MAINTENANCE

- Annual calibration of gauge is recommended.
- Periodically inspect components for overall condition. Replace as necessary.
- Perform maintenance and trouble shooting of regulator per Appendix II

7.0 PROVISION OF SPARES**7.1 SOURCE OF SPARE PARTS**

Spare parts may be obtained from the manufacturer:

TRONAIR, Inc.	Telephone: (419) 866-6301 or 800-426-6301
1 Air Cargo Pkwy East	Fax: (419) 867-0634
Swanton, Ohio 43558 USA	E-mail: sales@tronair.com
	Website: www.tronair.com

For Spare Parts, Operations & Service Manuals or Service Needs:
Scan the QR code or visit Tronair.com/aftermarket

**7.2 RECOMMENDED SPARE PARTS LISTS**

Reference the following page(s) for Replacement Parts and Kits available.

8.0 GUARANTEES/LIMITATION OF LIABILITY

Tronair products are warranted to be free of manufacturing or material defects for a period of one year after shipment to the original customer. This is solely limited to the repair or replacement of defective components. This warranty does not cover the following items:

- Parts required for normal maintenance
- Parts covered by a component manufacturers warranty
- Replacement parts have a 90-day warranty from date of shipment

If you have a problem that may require service, contact Tronair immediately. Do not attempt to repair or disassemble a product without first contacting Tronair, any action may affect warranty coverage. When you contact Tronair be prepared to provide the following information:

- Product Model Number
- Product Serial Number
- Description of the problem

If warranty coverage is approved, either replacement parts will be sent or the product will have to be returned to Tronair for repairs. If the product is to be returned, a Return Material Authorization (RMA) number will be issued for reference purposes on any shipping documents. Failure to obtain a RMA in advance of returning an item will result in a service fee. A decision on the extent of warranty coverage on returned products is reserved pending inspection at Tronair. Any shipments to Tronair must be shipped freight prepaid. Freight costs on shipments to customers will be paid by Tronair on any warranty claims only. Any unauthorized modification of the Tronair products or use of the Tronair products in violation of cautions and warnings in any manual (including updates) or safety bulletins published or delivered by Tronair will immediately void any warranty, express or implied.

The obligations of Tronair expressly stated herein are in lieu of all other warranties or conditions expressed or implied. **Any unauthorized modification of the Tronair products or use of the Tronair products in violations of cautions and warnings in any manual (including updates) or safety bulletins published or delivered by Tronair will immediately void any warranty, express or implied and Tronair disclaims any and all liability for injury (WITHOUT LIMITATION and including DEATH), loss or damage arising from or relating to such misuse.**

Parts List

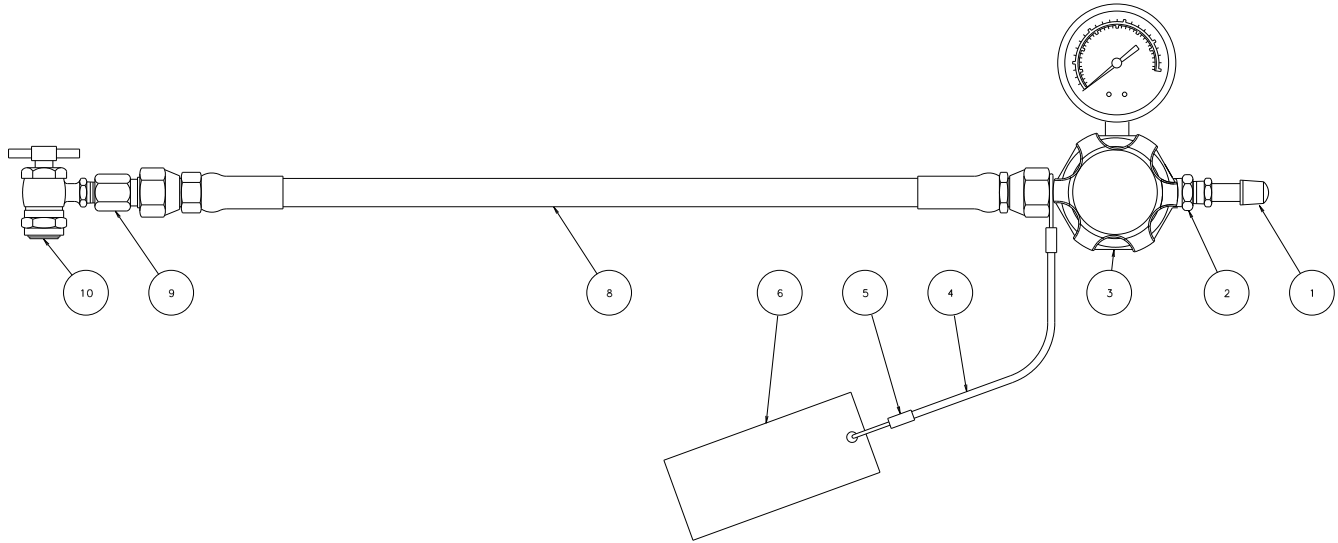

Item	Part Number	Description	Qty
1	H-1221	Valve, Air	1
2	N-2210-02-B	Reducer, Pipe Thread	1
3	PC-1142	Regulator, Low Pressure	1
4	H-1389	Lanyard	1
5	H-1390	Ferrule	2
6	V-1994	Label, Maximum Operating Pressure 15 psi	1
8	TF-1043-15*16.0	Assembly, Hose	1
9	N-2010-08-S	Connector, Female	1
10	PC-1007	Connector, Pressure	1



Instrument Certification Notice

The gauge Certificates of Calibration supplied for the gauge(s) on this unit contain the calibration data for the actual instrument calibrated, along with the calibration date of the **STANDARD** used to perform the calibration check.

The due date for re-calibration of the instrument should be based upon the date the instrument was placed in service in your facility. Re-calibration should be done on a periodic basis as dictated by the end user's quality system or other overriding requirements.

Note that Tronair, Inc. does not supply certificates of calibration on flow meters or pyrometers unless requested at the time of placed order. These instruments are considered reference indicators only and are not critical to the test(s) being performed on the aircraft.



Statement of Compliance

Tronair has assessed the equipment described below against the Requirements of the Directive listed below. Based on Article 4, Section 3 of the directive, the equipment shall not carry the CE mark.

This equipment has been designed and manufactured in accordance with Sound Engineering Practice.

This statement of compliance is issued under the sole responsibility of the manufacturer.

Model Number(s) 18-4216-6000

Product Type/Name: Low Pressure Nitrogen Regulator

Directive: Pressure Equipment Directive 2014/68/EU, Article 4: Section 3
Without prejudice to other applicable Union harmonization legislation providing for its affixing, such equipment or assemblies shall not bear the CE marking.

Identification of person empowered to sign on behalf of the Manufacturer:

A handwritten signature in black ink that reads "Patrick Finch". The signature is written in a cursive, flowing style.