



OPERATION & SERVICE MANUAL

Models: eJP-3, eJP-3L Electric Towbarless Tug



04/2024 – Rev. 06

**For Spare Parts, Operations & Service Manuals or Service Needs
Scan the QR code or visit [Tronair.com/aftermarket](https://www.tronair.com/aftermarket)**



The Tronair Group of Companies: Tronair | DatcoMedia | Columbus Jack | Eagle | DAE | Malabar International

Tronair, Inc.
1 Air Cargo Pkwy East
Swanton, OH 43558

Phone: (419) 866-6301 | 800-426-6301
Web: www.tronair.com
Email: sales@tronair.com

REVISION	DATE	TEXT AFFECTED
01	03/2018	Original Release
02	07/2019	Modified Parts List
03	12/2019	Major revision
04	01/2020	Major revision
05	12/2022	Modified Parts List
06	04/2024	Modified 12.2 Recommended Spare Parts List

TABLE OF CONTENTS

PAGE

1.0	PRODUCT INFORMATION	1
1.1	DESCRIPTION.....	1
1.2	MODEL & SERIAL NUMBER.....	1
1.3	MANUFACTURER.....	1
1.4	GENERAL.....	1
2.0	SAFETY INFORMATION.....	2
2.1	USAGE AND SAFETY INFORMATION.....	2
2.2	OPERATING SAFETY GUIDELINES.....	2
2.3	BATTERY SAFETY GUIDELINES.....	3
2.4	GROUND POWER UNIT SAFETY GUIDELINES.....	3
2.5	SAFETY GUIDELINES.....	4
3.0	TRAINING.....	5
3.1	TRAINING REQUIREMENTS.....	5
3.2	TRAINING PROGRAM.....	5
3.3	OPERATOR TRAINING.....	5
4.0	SPECIFICATIONS.....	6
4.1	DIMENSIONS.....	6
4.2	BATTERIES.....	6
4.3	GROUND POWER UNIT.....	6
4.4	CAPACITY.....	6
4.5	STANDARD EQUIPMENT.....	6
4.6	OPTIONAL EQUIPMENT AVAILABLE.....	6
4.7	ADD ON KITS.....	6
5.0	TECHNICAL DATA.....	7
5.1	FRAME AND COMPONENTS.....	7
5.2	DRIVE MOTOR.....	7
5.3	MOTOR SPEED CONTROL.....	7
5.4	POWER TRANSMISSION.....	7
5.5	BATTERIES.....	7
5.6	GROUND POWER UNIT.....	7
5.7	BATTERY CHARGER.....	7
5.8	BRAKING.....	7
5.9	PARKING BRAKE.....	7
5.10	WINCH.....	7
5.11	LIFT CRADLE.....	7
5.12	STEERING AXLE.....	7
5.13	STEERING.....	7
5.14	LIGHTING.....	7
5.15	DRIVE TIRES.....	8
5.16	OPERATORS PLATFORM.....	8
6.0	OPERATING INSTRUCTIONS.....	8
6.1	LOADING AIRCRAFT.....	9
6.2	UNLOADING AIRCRAFT.....	10
7.0	GROUND POWER UNIT.....	10
7.1	DESCRIPTION.....	10
7.2	CONNECTION TO AIRCRAFT.....	10
7.3	DETERMINING PROPER VOLTAGE.....	10
8.0	BATTERY CARE.....	11
8.1	WATER.....	11
8.2	CHARGING.....	11
8.3	PRECAUTIONS.....	11
8.4	BATTERY MAINTENANCE.....	11
9.0	TROUBLESHOOTING.....	12
9.1	GENERAL TROUBLESHOOTING.....	12
9.1.1	If The Tug Will Not Run.....	12
9.1.2	If Tug Runs But Lacks Sufficient Power.....	12
9.2	BATTERY CHARGER TROUBLE SHOOTING.....	12
9.3	CRADLE UP OR DOWN DOESN'T WORK.....	12
10.0	MAINTENANCE.....	13
10.1	GENERAL MAINTENANCE.....	13
10.2	LUBRICATION.....	13
10.3	NYLON STRAPS.....	14
10.4	COMPONENT WEAR.....	14
10.5	REPAIRS.....	14

11.0 PRE-SHIFT CHECKLIST 15
12.0 PROVISION OF SPARES 16
 12.1 SOURCE OF SPARE PARTS 16
 12.2 RECOMMENDED SPARE PARTS LISTS 16
13.0 IN SERVICE SUPPORT 16
14.0 GUARANTEES/LIMITATION OF LIABILITY 16
15.0 APPENDICES 17

This product can not be modified without the written approval of Tronair, Inc. Any modifications done without written approval voids all warranties and releases Tronair, Inc., its suppliers, distributors, employees, or financial institutions from any liability from consequences that may occur. Only Tronair OEM replacement parts shall be used.

1.0 PRODUCT INFORMATION

1.1 DESCRIPTION

Electric towbarless tug for moving aircraft 30,000 lbs or less.

1.2 MODEL & SERIAL NUMBER

Reference nameplate on unit

1.3 MANUFACTURER

TRONAIR, Inc.
1 Air Cargo Pkwy East
Swanton, Ohio 43558 USA

Telephone: (419) 866-6301 or 800-426-6301
Fax: (419) 867-0634
E-mail: sales@tronair.com
Website: www.tronair.com

1.4 GENERAL

Model Numbers:..... eJP-3, eJP-3L
Battery:
Type Deep Cycle
Voltage 6 V (48V System)
Amp Hours 235 (eJP-3), 470 (eJP-3L) (20 hr rate)

Battery Charger eJP-3:
Type Delta Q on-board
Rating 25 amp

Battery Charger eJP-3L:
Type Eco Charge off-board
Rating 50 amp

WARNING



Failure to comply with this warning may result in personal injury or death and may cause significant damage to the aircraft and/or tug

CAUTION



Pay careful attention to avoid damage to tug and/or aircraft

2.0 SAFETY INFORMATION**2.1 USAGE AND SAFETY INFORMATION**

To insure safe operations please read the following statements and understand their meaning. Also refer to your equipment manufacturer's manual for other important safety information. This manual contains safety precautions which are explained below. Please read carefully.



WARNING! — Warning is used to indicate the presence of a hazard that **can cause severe personal injury, death, or substantial property damage** if the warning notice is ignored.

CAUTION! — Caution is used to indicate the presence of a hazard that **will or can cause minor personal injury or property damage** if the caution notice is ignored.

2.2 OPERATING SAFETY GUIDELINES

1. **Under normal circumstances do not use the Parking Brake Hand Button to stop the tug while moving.** The Parking Brake Hand Button is provided to set the parking brake faster when stopped on an Incline. When stopping the tug on an incline, hold the vehicle to a stop using the Joystick. Press and hold the Parking Brake Hand Button before releasing the Joystick. This will eliminate the time lapse between releasing the Joystick and the automatic setting of the parking brake.
2. Tug motion is normally stopped by moving the Joystick to the Neutral (upright) position. Moving the Joystick through Neutral and into the opposite direction will supply the same braking effort as moving it to the Neutral position.

**WARNING**

Available stopping torque is reduced when the transmission is set for high gear. Stopping distances may be longer when the transmission is set for high gear.

3. Always use the safety strap and tighten snugly. This will prevent the aircraft from rolling forward if a sudden stop occurs.
4. Accelerate slowly. Always operate the tug as smoothly as possible to prevent damage to the nose wheel strut of the towed aircraft.
5. Do not leave tug unattended when children are present.
6. Do not allow anyone to "sit", or "ride", on the deck of the tug while in motion.
7. The tug is equipped with a safety brake which prevents the vehicle from moving when the systems are off. However, the tug can be moved or towed by putting the transaxle into neutral. Standing on the cradle looking aft, the shift knob is located on the right side of the transaxle. Look for a round stop collar fastened to a shaft sticking out the side. When the knob is pushed all the way in, it is in low gear. Pull it out half way and the transaxle is in neutral. Pull it all the way out for high gear.
8. The tug is equipped with a safety brake which prevents the vehicle from moving when the systems are off. However, the tug can be moved or towed by putting the transaxle into neutral. Standing on the cradle looking aft, the shift knob is located on the right side of the transaxle. Look for a round stop collar fastened to a shaft sticking out the side. When the knob is pushed all the way in, it is in low gear. Pull it out half way and the transaxle is in neutral. Pull it all the way out for high gear.

WARNING

When the transmission is set to the Neutral position, the tug is free to roll and the brakes will be ineffective. Use this position only for the purpose of slowly moving on a non-functioning tug. Wheel chocks may be needed for stopping. Otherwise, be sure the transmission is firmly set to the full in position (low speed) or the full out position (high speed).

9. Routinely inspect the spring on the hand winch for proper tension. Over time this spring may relax and not keep the dog firmly in the sprocket which could allow the winch to unspool and let the aircraft roll off the front of the cradle and cause damage to the aircraft or injury to people or objects nearby. Maintain a firm grip on the winch handle at all times and never release the handle when the ratchet lever is in unlocked position with a load on the winch. Otherwise, the handle will spin violently which could cause personal injury.
10. Use extreme caution while operating under adverse weather conditions. With snow or ice on the ramp traction can be reduced significantly which could result in loss of control of tug and towed aircraft. Evaluate weather conditions to determine if the aircraft can be moved safely. If in doubt do not attempt to move aircraft.

2.3 BATTERY SAFETY GUIDELINES

1. Always wear eye protection and rubber gloves when working with batteries.
2. Never wear jewelry, watches or rings while working around batteries.
3. When working on tug, always remove all power leads from batteries. The battery pack is capable of extremely high currents and could cause serious damage or injury if short-circuited.
4. If battery acid is accidentally spilled on the skin, immediately flush the area with large amounts of water.
Electrolyte splashed in the eyes is extremely dangerous! If this should happen, force the eye open and flood it with cool, clean water for approximately fifteen minutes. A doctor should be called immediately when the accident occurs.
5. If you have any doubts or questions, contact Tronair.

2.4 GROUND POWER UNIT SAFETY GUIDELINES

1. Read 6.4 "Safety Precautions" in the battery care section of this manual.
2. Never guess when it comes to high current electrical equipment. Think about what you are doing before you do it.
3. Read and understand the cautionary statements in above section.
4. Always plug the black plug into the black socket. Reverse voltage can damage aircraft electrical systems.
5. Never over boost the electrical system by using a higher voltage than the rated voltage for the aircraft.
6. Pressing the Emergency Stop Button will disconnect the negative side of the GPU circuit. The Emergency Stop Button must be in the pulled up position for the GPU to function.

2.5 SAFETY GUIDELINES

1. **DO NOT USE THE PARKING BRAKE HAND BUTTON TO STOP THE TUG WHILE MOVING.** The Parking Brake Hand Button allows faster setting of the parking brake for stopping and holding on inclines.
2. Tug motion is normally stopped by returning the Joystick to the Neutral upright position. Moving the Joystick through Neutral and into the opposite direction will result in the same braking effort as moving it to Neutral.

**WARNING**

Available stopping torque is reduced when the transmission is set for high gear. Stopping distances may be longer when the transmission is set for high gear.

3. Accelerate slowly. Always operate the tug as **SMOOTHLY AS POSSIBLE TO PREVENT DAMAGE TO THE NOSE WHEEL STRUT OF THE TOWED AIRCRAFT.**
4. **DO NOT LEAVE TUG UNATTENDED WHEN CHILDREN ARE PRESENT.**

**WARNING**

Do not allow anyone to sit or ride on the diamond plate or front fenders of the tug while in motion.

5. The tug is equipped with a safety brake, which prevents the vehicle from **MOVING** when the systems are off. However, the tug can be moved or towed **by putting the transmission in neutral.**

**WARNING**

When the transmission is set to the Neutral position, the tug is free to roll and the brakes will be ineffective. Use this position only for the purpose of slowly moving on a non-functioning tug. Wheel chocks may be needed for stopping. Otherwise, be sure the transmission is firmly set to the full in position (low speed) or the full out position (high speed).

6. Operators are **EXPECTED TO KNOW AND OBSERVE ALL NORMAL SAFETY PROCEDURES FOR WORKING AROUND AIRCRAFT. THE OPERATOR'S KNOWLEDGE OF THESE GENERAL AVIATION SAFETY PROCEDURES IS A BASIC ASSUMPTION FOR THIS MANUAL. THE OMISSION OF GENERAL AIRCRAFT SAFETY PROCEDURES FROM THE OPERATION & SERVICE MANUAL IS NO EXCUSE FOR THE OPERATOR'S FAILURE TO APPLY THEM.**
7. **IN THE EVENT THE GROUND POWER UNIT (GPU) IS USED, THE OPERATOR IS EXPECTED TO HAVE A WORKING KNOWLEDGE OF ELECTRICAL CHARACTERISTICS OF THE SPECIFIC AIRCRAFT BEING ASSISTED. DAMAGE TO THE AIRCRAFT'S ELECTRICAL SYSTEM CAN OCCUR FROM OVER VOLTAGE, LACK OF PROPER ISOLATION OR INCORRECT POLARITY. SUCH MISHAPS ARE ENTIRELY PREVENTABLE IF THE OPERATOR KNOWS THE AIRCRAFT CHARACTERISTICS AND PROCEEDS WITH CARE.**
8. **FOR MOVING AIRCRAFT UP OR DOWN INCLINES/SLOPES, A QUALIFIED OPERATOR SHOULD BE IN THE AIRCRAFT COCKPIT TO UTILIZE THE AIRCRAFT'S BRAKES FOR SAFETY/BACKUP.**
9. **THE TUG, LIKE ANY PIECE OF MACHINERY, SHOULD BE OPERATED BY RESPONSIBLE PERSONNEL WHO ARE ALERT, ATTENTIVE AND AWARE OF THE POTENTIAL FOR SERIOUS INJURY OR DEATH. OPERATORS SHOULD NOT BE UNDER THE INFLUENCE OF INTOXICANTS, DRUGS OR ANY SUBSTANCE THAT WOULD ALTER OR IMPAIR THEIR ACTIONS OR ABILITY TO MAKE RESPONSIBLE AND PRUDENT JUDGMENTS. NO PERSON SHOULD BE ALLOWED TO OPERATE THE TUG WITHOUT READING AND UNDERSTANDING THIS OPERATOR MANUAL.**
10. **PROPER ATTIRE SHOULD BE WORN WHILE OPERATING TUG. LOOSE FITTING CLOTHING SHOULD BE AVOIDED. APPROPRIATE OUTDOOR WORK SHOES SHOULD BE WORN AT ALL TIMES.**
11. **EYE PROTECTION AND RUBBER GLOVES SHOULD BE WORN WHEN ADDING WATER OR WORKING WITH THE BATTERIES. REMEMBER THAT THE CURRENT CAPABILITY OF THE BATTERIES IS EXTREMELY HIGH.**
12. **IMPORTANT! ALL SWITCHES NEED TO BE TURNED OFF BEFORE PLUGGING IN THE TUG FOR CHARGING.**
13. **THE DIAMOND PLATE OVER THE BATTERIES SHOULD ALWAYS BE REMOVED WHEN CHARGING THE BATTERIES. DURING THE CHARGING CYCLE, EXPLOSIVE HYDROGEN GAS is expelled. Open flame or sparks must be avoided. Do not smoke near the batteries while charging**
14. **Read SECTION 6 AND REVIEW AND UNDERSTAND SAFETY PROCEDURES FOR WORKING AROUND BATTERIES.**
15. **WHEN MOVING IN REVERSE DIRECTION, LOOK BOTH WAYS AND CLEAR THE AREA OF OTHER TRAFFIC AND OBSTACLES.**
16. **CONTACT** Tronair before making substitutions of any parts.

3.0 TRAINING

3.1 TRAINING REQUIREMENTS

The employer of the operator is responsible for providing a training program sufficient for the safe operation of the tug.

3.2 TRAINING PROGRAM

The employer provided operator training program should cover safety procedures concerning use of the tug in and around the intended aircraft at the intended aircraft servicing location.

3.3 OPERATOR TRAINING

The operator training should provide the required training for safe operation of the tug.

NOTE: Maintenance and Trouble Shooting are to be performed by a skilled and trained technician.

5.0 TECHNICAL DATA**5.1 FRAME AND COMPONENTS**

Heavy gauge steel, laser-cut, formed and welded into a structural unit.

5.2 DRIVE MOTOR

A six horsepower, 48 volt, direct current, continuous duty-cycle motor, designed specifically for tug, is coupled directly to the transmission by bevel gearing.

5.3 MOTOR SPEED CONTROL

A solid-state controller, utilizing the latest MOSFET technology, controls the drive motor. Current limit, controlled acceleration and braking current are digitally programmed into each unit before shipment. A digital display on the console displays hours of use and charge level of the batteries.

5.4 POWER TRANSMISSION

Power transmission is by means of a two-speed transaxle, with all gear drive components operating in an oil bath. There are no chains, couplings, belts or U-joints in the drive train.

5.5 BATTERIES

The eJP-3 has eight 6 volt batteries connected in series for 48 volts and 235 Ah (20 hr rate). The eJP-3L has sixteen 6 volt batteries connected in series and parallel for 48 volts and 470 Ah (20 hr rate).

5.6 GROUND POWER UNIT

30 volts are provided to assist starting aircraft engines. Fourteen feet of cable and two types of GPU plugs are provided, including Cessna-style and Piper-style ends.

5.7 BATTERY CHARGER

eJP-3 A built-in automatic 25 AMP 48 Volt DC charger runs on 100-240 VAC, 50/60 HZ input voltage. Input amperage is 13.4 amps at 100 VAC. Open the ventilation door while charging.

eJP-3L Off-board 50 AMP 48 Volt DC charger. Specify input voltage when ordering.

5.8 BRAKING

Regenerative braking is provided by the solid state motor controller. Braking occurs as the Joystick is moved toward the Neutral upright position. Braking strength ramps up based on the programmed deceleration curve.

5.9 PARKING BRAKE

An electrically released disk brake is mounted on the drive motor. The parking brake sets automatically when the Person Present (deadman) switch on the Joystick is released **and** regen braking has brought the tug to a stop. A Parking Brake Hand Button is to the left of the steering wheel. This button is to be used to eliminate the time lags between the release of the Joystick and the automatic setting of the parking brake when stopping on inclines.

5.10 WINCH

A heavy duty, two-speed hand winch is standard. A nylon strap is included so that aircraft will not be damaged or scratched.

5.11 LIFT CRADLE

A direct current motor and hydraulic pump operate two lift cylinders that raise and lower the nose wheel lift cradle. Control is by "Raise" and "Lower" push buttons located on the control panel. The lift cradle is designed to accommodate both dual and single nose wheels.

5.12 STEERING AXLE

Dual 4.80 x 8" (16 inch O.D.) industrial tires are used for steering. The steering axle assembly rides on tapered roller bearings, as do the wheels. The steering axle moves in a 120° arc to provide a very tight turning radius.

5.13 STEERING

A 16" industrial steering wheel provides comfortable steering without power assist. An industrial oil bath gear reducer provides primary gear reduction. Secondary reduction is provided by roller chain. The steering wheel is tilted rearward 10° from horizontal to provide the most comfortable and efficient driving position.

5.14 LIGHTING

Forward and rear LED headlights are included. Headlights are turned on with toggle switch. Strobe comes on when tug is started.

5.15 DRIVE TIRES

Drive tires are 16 x 6-8 solid rubber traction tires.

5.16 OPERATORS PLATFORM

The operator's platform is designed to accommodate the operator and one passenger. The platform is free from pedals and brake levers that encumber the operator.

6.0 OPERATING INSTRUCTIONS

1. Stand on Operator Platform and pull the E-stop up.
2. Turn the "Off-On-Start" switch to the "Start" position and then release.
3. When operating the tug, stand firmly on the operator's platform, with legs spread slightly apart and body braced against the backrest. Keep one hand firmly on the steering wheel and the other on the Joystick. Do not move tug any faster than is necessary.
4. Make sure the cradle is raised off the ground. Grab the Joystick and squeeze the Person Present (deadman) switch. Slowly move the Joystick in the desired direction of travel. If you activate the throttle before squeezing deadman switch, your tug will not move. This is a safety feature built into the controller. Release the throttle back to neutral and start over in the direction you want to travel.
5. This vehicle is NOT designed to coast. Accelerating, braking, and maintaining a constant speed are all very dependent on Joystick position. This results in a vehicle that is very easy to drive and extremely easy to control on inclines. Squeeze and hold the deadman switch on the Joystick. Slowly move the Joystick in the Forward or Reverse direction to accelerate; slowly move the Joystick back to center to brake. Hold the Joystick steady for a steady speed.
6. Moving the Joystick back to center, moving the Joystick into the opposite direction, or releasing the deadman lever will all brake at the same rate.
7. The Parking Brake Hand Button can be used for more precise stopping on inclines. Hold the tug to a stop using the Joystick; press and hold the Parking Brake Hand Button before releasing the Joystick. This will eliminate the time laps between releasing the deadman and the automatic setting of the parking brake.

**WARNING**

Available stopping torque is reduced when the transmission is set for high gear. Stopping distances may be longer when the transmission is set for high gear.

**WARNING**

Do not make sharp turns while moving rapidly. Always look behind you before backing up.

6.1 LOADING AIRCRAFT

1. **Check with the owner/operator of the aircraft to determine what precautions need to be taken to properly tow the aircraft.** Determine if any steering linkages or other components need to be disconnected or bypassed in order to allow the nose wheel to turn within its prescribed turning limits.
2. The lift cradle is equipped with three sets of holes in the side support arms to accept a 1" diameter 20" long bar. The top two sets of holes are to be used for aircraft without nose wheel pants. Based on the diameter of the nose wheel put the bar through the set of holes that will best handle that particular aircraft. The top hole for example would be used for large diameter (18") single nose wheel Cessna Citations or Lear Jets. Put the bar through the lowest set of holes only for single engine aircraft that have nose wheel pants. The nose wheel pant will slide over the top of the bar.



Note: With whatever set of holes you use, lift the cradle only high enough off the ground to clear obstacles while moving the aircraft. If you raise the cradle too high a sudden stop or other circumstance could cause the nose wheel of the aircraft to roll over the top of the bar and onto the tug causing damage to the aircraft and possible injury to the operator.

To avoid this situation use the safety strap as described in #3. Notice that the moveable side plates are tapered as they go forward. This is to keep the side plates from touching the bottom of the side of the wheel pant when the cradle is raised. Pay attention as you raise the cradle and make sure you do not raise it too high and allow the side plates to contact the bottom of the wheel pant.

3. Position the tug in front of the aircraft nose wheel and lower the lift cradle to the ground. Winch the nose wheel onto the lift cradle, utilizing the strut strap or appropriate attachment. **Make sure there is a little slack in the winch strap before lifting the cradle as it will move up and away from the tug as it is raised. This will increase the tension in the strap and could damage the aircraft nose wheel assembly as the cradle is being raised.** Once the cradle is raised to the desired height then retighten the winch strap so it has adequate tension in it to keep the aircraft secure in the cradle. Some aircraft have sensors or other components attached to the nose wheel strut and may be damaged by using the nylon strut strap. In such cases do not move the aircraft unless you have an appropriate towing adapter. Check for proper ratchet operation on each use of the winch. Do not use if ratchet will not lock properly, seek immediate repairs.
4. Secure the aircraft nose wheel with the safety strap. The safety strap is a strap with a ratchet mechanism and spring clip hooks at each end. On either side of the forward end of the cradle are brackets that have a hole in each of them. These holes on either side are used for the safety strap. After the aircraft has been winched onto the cradle hook one end of the safety strap to one side of the cradle and position the strap up and over the top of the nose wheel (or nose wheel pant) and in front of the oleo strut. Hook the other end into the hole on the other side of the cradle and use the ratchet to snug up the strap. Be very careful not to position the strap where it might damage some component of the nose wheel assembly. Do not over tighten as it only needs to be snug enough to prevent the nose wheel from possibly lifting upward out of the cradle. On some aircraft with nose wheel pants it may make sense to run the safety strap through a scissors on the aft side of the strut.
5. If the aircraft has a single nosewheel versus a dual nosewheel then the moveable side plates will be needed in order to keep the nose wheel from twisting or rotating while the aircraft is being moved. Once the nose wheel is in position on the cradle, lift up on the ring of the index plunger on top of the square tube on the cradle and slide the moveable side plate in the proper direction. If you release the ring on the plunger when you start to reposition the side plate it will drop into the next available hole of the inner square tube.
6. Raise the lift cradle high enough to clear obstacles on the ground.
7. If moving aircraft over 15,000 lbs make sure the transaxle is in LOW gear. The knob for this is located on the right side of the transaxle as you are standing on the cradle looking aft towards the steering wheel. There is a sticker on the front center of the transaxle that shows to push the shaft all the way in (to your left) to place it in low gear.
8. Move the aircraft by slowly advancing the accelerator lever in the direction of travel.
9. For moving aircraft up or down inclines/slopes, a qualified operator should be in the aircraft cockpit to utilize the aircraft's brakes for safety/backup.

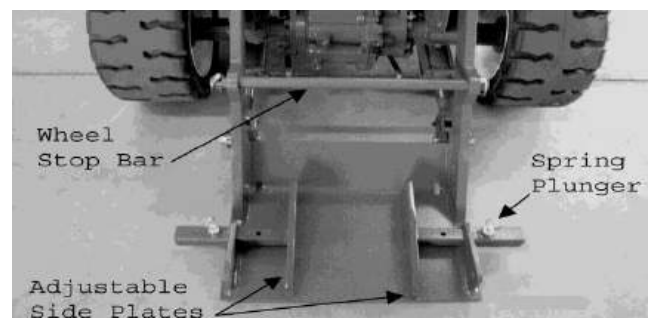
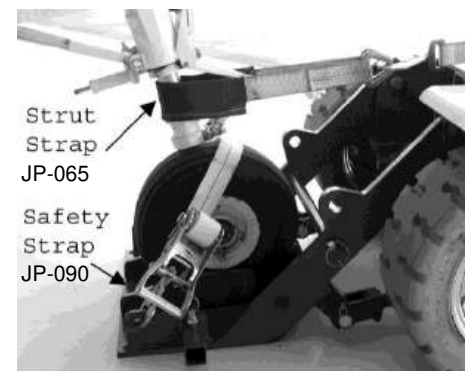

6.2 UNLOADING AIRCRAFT

1. To unload aircraft, lower lift cradle to a position 1/2" above the ground. Remove strut strap and safety strap.
2. Chock the aircrafts main wheels and then back tug away from the aircraft, allowing the nose wheel of the aircraft to roll off lift cradle onto the ground.

7.0 GROUND POWER UNIT

7.1 DESCRIPTION

1. The ground power unit (GPU) is an integral part of tug. The traction batteries serve as the source of power to start the aircraft.
2. The black terminal is the negative, terminal. Always connect the black plug into the black terminal. This provides the ground connection to the aircraft.
3. The first red terminal is the 12 volt terminal. With the batteries in a fully charged condition, the terminal voltage will be closer to 14 volts. With the batteries in a partially charged condition, the voltage will be typically closer to 12 volts. To assist a 12 volt aircraft, plug the black lead into the black terminal and the red plug into the 12 volt terminal.
4. The second red terminal, labeled 24 volt, is used to start aircraft with 24 volt systems. Plug the black plug into the black terminal and the red plug into the 24/ volt terminal. When the batteries are in a fully charged condition, the voltage will be near 26 volts. As the batteries are used, the voltage will decrease to nearly 24 volts.
5. The third red terminal, labeled 30 volt, may be used to start 28 volt aircraft, especially in cold weather, or when conditions require additional voltage. Check with the aircraft owner/operator to make sure the increased voltage is within the aircraft's electrical system tolerances. When the batteries are in a fully charged condition, the voltage will be near 31 volts. This increased voltage will make starting easier.



CAUTION

Do not use the 30 volt terminal unless the aircraft electrical system is isolated from the starting circuit. The over voltage could damage the aircraft's electrical system.

6. The GPU positive voltage is connected directly to the traction batteries and does not have a fuse in the circuit. Pressing the E-stop will disconnect the negative side of the GPU circuit. Be extremely careful when handling the GPU cables. Extremely high currents are possible.

7.2 CONNECTION TO AIRCRAFT

1. Adapters are included with tug. Position tug so the power socket on the aircraft is in a location that will allow the engine to be started safely. Be sure the "Master" switch in the aircraft is off prior to starting the engines. Boost voltage could damage the aircraft's electrical system.



WARNING

Consult the owner/operator of the aircraft to confirm proper procedures for a GPU start.

2. Determine the voltage of the aircraft that is to be boosted. Attach the appropriate adapter to the end of the long boost cables. Connect the black plug (negative) into the black socket in the front of the GPU panel. **Always connect the GPU cables to the tug first before making connection to the aircraft.**
3. Connect the red plug into the appropriate red socket in the front of the GPU panel. Be sure that the voltage selected is correct for the Aircraft that is being boosted. **Again, make sure the connection is made to the tug prior to connecting to the aircraft.**



CAUTION

Do not allow aircraft to draw full power for more than one minute in ten minutes. Excessive use of the GPU could cause severe heating and damage the batteries and/or GPU cables.



WARNING

Do not use the GPU system to run aircraft heating and cooling systems. The GPU system is not designed to handle these continuous loads and can cause damage to the batteries and GPU cables. Under these circumstances the batteries could produce explosive gases which, if ignited, may cause serious injury to nearby personnel.

4. Once the aircraft engine has started, disconnect the GPU cable at the aircraft then from tug. Carefully wind the GPU cables and stow them in one of the storage compartments on tug.

7.3 DETERMINING PROPER VOLTAGE

1. Check the aircraft ratings to determine the proper voltage, if unknown. DO NOT GUESS. Over-voltage can damage aircraft electrical systems.
2. Do not unplug the GPU cables while the aircraft is being started. High currents can cause severe arcing.

8.0 BATTERY CARE

This section provides general instructions for good battery care. Please refer to Appendix in this section for additional information on battery care.

8.1 WATER

1. Add approved water only to a fully charged battery. You can use local tap water as long as it is not high in mineral deposits or other hard deposits.
2. Keep electrolyte water level above separator protectors.
3. Keep battery cells filled to proper level. Low water can cause permanent damage to batteries.
4. Check water level once a week. Replace water lost to evaporation. Never add water to a discharged battery.
5. Never add sulfuric acid to a battery.
6. Do not transfer acid from one cell to another.
7. Never allow the batteries to stand in an uncharged state. Plate damage will occur.

8.2 CHARGING

1. **Keep battery compartment open during charging to ensure proper ventilation.**
2. The batteries should be recharged when the state of charge indicator has declined to 30-40%.
For the Honeywell state of charge indicators, charge when the yellow LED lights are down to 3. This will be in the 30-40% range. The last yellow LED will begin to flash when the charge drops below 25%.
For the Curtis state of charge indicators, charge when the LEDs in the yellow range are showing. This will be in the 30-40% range. There are 3 LEDs in the yellow range. At 30% charge, there will be a flashing red LED. At 20% charge, there will be a double flashing red LED.
Do not skim charge or constantly top up the batteries, as this will shorten the life considerably.
If the vehicle is not being used, batteries should be stored at full charge and topped up monthly.
3. Keep flame and metal away from the battery tops to prevent battery gasses from exploding.
4. Cool before charging or operating, if battery is above 115° F.
5. The Emergency Stop Switch **MUST** be in the "off" position during charging.

8.3 PRECAUTIONS

1. Keep battery tops clean and dry.
2. Keep vent caps tightly in place.
3. Do not use battery with specific gravity below 1.155.
4. Be sure battery compartment cover is removed and they are well vented while charging batteries.
5. Do not overcharge batteries. Allow several hours use between charges.

8.4 BATTERY MAINTENANCE

See Appendix I for additional information on battery maintenance.

9.0 TROUBLESHOOTING**9.1 GENERAL TROUBLESHOOTING****9.1.1 If The Tug Will Not Run**

- Is the E-stop button depressed? Pull up to release.
- Check the wire connections on the joystick and make sure no wires have come loose.
- Check switch positions. Are E-stop and start switches on?
- Are you squeezing the deadman switch on the Joystick. The deadman switch must be squeezed before moving the Joystick and held continually for the vehicle to move.
- Check that all battery connections are tight and show no signs of corrosion.
- Check that all batteries are fully charged and that none has defective cells.
- Check wiring for loose connections.
- Check for faulty forward-reverse switches. They are on the bottom of the joystick.
- Check for worn motor brushes.
- Check direction switches on the Joystick and see if they are engaging and sending voltage to controller.
- Make sure wire harness plugs are seated correctly in controller.

9.1.2 If Tug Runs But Lacks Sufficient Power

- Check batteries – specific gravity
- Check to see that brakes are not dragging.
- Check all battery and switch connections to see that they are clean and tight.
- Check for loose wiring.

9.2 BATTERY CHARGER TROUBLE SHOOTING

See Appendix V

9.3 CRADLE UP OR DOWN DOESN'T WORK

If the cradle goes one direction but not the other, or goes really slow in the other direction it could be a faulty coil on one of the cartridge valves or missing wiring if wiring has been disconnected for some reason. If one coil doesn't work then fluid can flow one direction because the powered side cartridge valve will work and the return fluid will push open the other valve. But the reverse will not work as the non-working cartridge valve can't open therefore preventing fluid from getting to the cylinders.

10.0 MAINTENANCE WARNING



All work on the tug should be performed by competent repair personnel. Before performing maintenance, review all safety procedures.

10.1 GENERAL MAINTENANCE

1. After the tug has been in operation for (4) months the steering chain should be tightened to take up the slack from initial chain stretch. If this is not done there is a chance that the steering chain could jump off the sprocket, which would cause the steering system to fail. Access the chain through the knee level panel at the driver's platform. Under the steering sub-frame there are three bolt heads facing down that screw into the steering ratio multiplier. Loosen these three bolts and pull the whole assembly back to tighten the chain. Retighten the three bolts while still applying tension to the steering assembly.
2. Check the electrical connections for loosening; tighten if necessary.
3. Check battery water level weekly
4. Paint the terminals of the batteries with acid-proof coating.
5. Check all bolts and hydraulic fittings for looseness. Tighten if necessary.
6. If battery acid should spill into the battery box or on metal parts, flush with water and baking soda. Sprinkle baking soda in bottom of battery box to prevent corrosion.



WARNING

Battery acid is corrosive. Wear gloves and eye protection when servicing batteries.

7. Keep tug in a clean condition. Check for any unusual conditions, such as bent metal or broken parts.
8. Electric vehicles, such as tug, should never be steam cleaned.
9. Tire Replacement. Replace worn tires with equal or greater capacity tires only. Do not change tire dimensions when replacing tires.

10.2 LUBRICATION

LUBRICATION CHART

Lube Point	Interval	Lube Spec	Remarks
Hydraulic Pump	Weekly	AW 46	Check level
Transaxle	Semi-annual	80/90 Wt. Gear lube Oil	Check level
Lift Cradle Pivots	Monthly	SAE 50	
Hydraulic Cylinders	Monthly	SAE 50	Lube both ends
Steering Roller Chain	Annually	Chain lube spray	
Steering Axle Hubs	Annually	Lithium Bearing Grease	Including top support hub
Steering Shaft Flange Bearing	Annually	Lithium Bearing Grease	Zirk fitting



CAUTION

To avoid potential injury or equipment damage, use proper support and block front tires when either end of tug is raised. Use blocks/jack stands capable of supporting 3,000 lbs.

1. Lubricate the pivot points on the lift cradle with SAE 50 oil on a monthly basis.
2. Lubricate both ends on the two hydraulic cylinders with SAE 50 oil on a monthly basis.
3. Lubricate the roller chain on the steering axle with chain lube spray on an annual basis. This can be accessed by raising the steering axle with a jack under the platform or through the knee level panel at the drivers platform.
4. Repack the steering shaft roller bearings with wheel bearing grease on an annual basis.
5. Repack the steering axle wheel bearings with wheel bearing grease on an annual basis. Clean bearings and remove all old grease using solvent. Do not mix greases having different bases.
6. Check the oil in the steering gearbox annually. Add SAE 90W, if necessary.
7. Check the oil level in the hydraulic reservoir every day during preoperational check. Add hydraulic oil, if necessary. Use an AW 46 hydraulic oil. Make sure the cradle cylinders are fully retracted prior to adding fluid. Fluid level should be at least one and half inches down from the top.
8. Check the transaxle fluid level every month. Remove the level screw which faces forward and is near the center line of the axle. If oil is not to this level, add SAE 90W at the filler plug on top of the transaxle. The transaxle holds seven (7) pints.
9. The motor bearings and the drive wheel bearings are sealed and require no lubrication.

10.3 NYLON STRAPS

1. **Pre-shift Inspection Of Straps:** Winch, strut and safety straps should be inspected during the daily pre-shift inspection process.

**WARNING**

These straps are the primary means of securing the aircraft to the tug. Failure of these components could result in death or serious injury and/or significant damage to the aircraft.

2. **Worn/Damaged Straps:** Discontinue use of any strap that shows signs of wear or damage such as torn or frayed edges, damaged "D" rings or hooks, loose or broken stitching, signs of chemical damage or holes in webbing of strap. See attached sheet for examples of unserviceable straps.
3. **Periodic Strap Inspection:** Strut and winch straps are degraded in tension capacity by normal wear, age and exposure to the elements. Operators should inspect straps daily during normal pre-shift inspection.
4. **Routine Strap Replacement:** Strut and winch straps should be associated with a specific tug and tracked for age. Straps should be routinely replaced annually or after 150 hours of use, whichever occurs first. Replacement is mandatory if inspection shows any wear or damage that would lower maximum capacity of the straps or fittings.
5. **Non-Routine Strap Replacement:** Enclosure (1) is provided as a guideline for inspecting straps. **Straps provide the primary securing device for your aircraft and as such should be of primary importance in the maintenance cycle.**

10.4 COMPONENT WEAR

1. The parking brake on the rear of the motor disk will wear very slowly. If the dynamic motor braking is utilized, the parking brake will last for many years.
2. Tires should be replaced when the tread depth is less than ¼ in.
3. **Motor Brushes:** Motor brushes will wear very slowly; however, they should be checked at least once a year.

10.5 REPAIRS

2. Repairs needed on your tug should be performed by competent repair personnel.
3. The batteries in your tug must be replaced with like batteries. The charger has been designed to operate with this size battery. Do not substitute a higher or lower Amp/hour rated battery. All batteries should be replaced at the same time.
4. **Do not attempt to repair the electronic controller.** Contact Tronair for proper repair procedures.
5. Contact Tronair before making substitutions of any parts.

11.0 PRE-SHIFT CHECKLIST

Perform this check every day prior to the first shift. Place X if ok.
Do NOT operate any tug until all discrepancies have been corrected

	Week Of: _____							
	Date							
Function	Inspected By							
Check Fluid Levels								
Hydraulic Reservoir								
Battery Water Level								
Condition Check								
Hydraulic Hoses								
Lift Cradle Hydraulic Lines								
Nylon Winch Strap								
Nylon Attachment Straps								
Tires								
Lights								
Operational Check								
Dynamic Motor Braking								
Steering								
Lift Cradle								
GPU Plugs								
Leak Check								
Hydraulic Pump Bay								
All Hydraulic Lines								
Battery Cases								
Monthly Torque Specs								
Drive Wheel Lug Nuts – 90 ft lbs								
Rear Wheel Lug Nuts – 90 ft lbs								

Make copies of this page for continued use.

12.0 PROVISION OF SPARES

12.1 SOURCE OF SPARE PARTS

Spare parts may be obtained from the manufacturer:

TRONAIR, Inc.

1 Air Cargo Pkwy East
Swanton, Ohio 43558 USA

Telephone: (419) 866-6301 or 800-426-6301

Fax: (419) 867-0634

E-mail: sales@tronair.com

Website: www.tronair.com

For Spare Parts, Operations & Service Manuals or Service Needs:
Scan the QR code or visit Tronair.com/aftermarket



12.2 RECOMMENDED SPARE PARTS LISTS

Reference the following page(s) for Replacement Parts and Kits available.

Recommended Spares:

- K-5347..... Battery Watering System Kit
- JP-065..... Strut Strap
- JP-069..... Winch Strap
- JP-090..... Nose Wheel Safety Strap
- EC-2258..... Compact 24 VDC (SPDT) Relay
- EC-2113-10.00..... 10 amp Fast Acting Fuse
- EC-2113-5.00..... 5 amp Fast Acting Fuse
- EC-2456..... Work Spot LED Light

13.0 IN SERVICE SUPPORT

Contact Tronair, Inc. for technical services and information. See Section 1.3 – Manufacturer.

14.0 GUARANTEES/LIMITATION OF LIABILITY

Tronair Platinum Warranty

Tronair products are warranted to be free of manufacturing or material defects for a period of two years after shipment to the original customer. This is solely limited to the repair or replacement of defective components. This warranty does not cover the following items:

- a) Parts required for normal maintenance
- b) Parts covered by a component manufacturers warranty
- c) Replacement parts have a 90-day warranty from date of shipment

If you have a problem that may require service, contact Tronair immediately. Do not attempt to repair or disassemble a product without first contacting Tronair, any action may affect warranty coverage. When you contact Tronair be prepared to provide the following information:

- a) Product Model Number
- b) Product Serial Number
- c) Description of the problem

If warranty coverage is approved, either replacement parts will be sent or the product will have to be returned to Tronair for repairs. If the product is to be returned, a Return Material Authorization (RMA) number will be issued for reference purposes on any shipping documents. Failure to obtain a RMA in advance of returning an item will result in a service fee. A decision on the extent of warranty coverage on returned products is reserved pending inspection at Tronair. Any shipments to Tronair must be shipped freight prepaid. Freight costs on shipments to customers will be paid by Tronair on any warranty claims only. Any unauthorized modification of the Tronair products or use of the Tronair products in violation of cautions and warnings in any manual (including updates) or safety bulletins published or delivered by Tronair will immediately void any warranty, express or implied.

The obligations of Tronair expressly stated herein are in lieu of all other warranties or conditions expressed or implied. **Any unauthorized modification of the Tronair products or use of the Tronair products in violations of cautions and warnings in any manual (including updates) or safety bulletins published or delivered by Tronair will immediately void any warranty, express or implied and Tronair disclaims any and all liability for injury (WITHOUT LIMITATION and including DEATH), loss or damage arising from or relating to such misuse.**

15.0 APPENDICES

APPENDIX I	INS-1857, Hydraulic Schematic
APPENDIX II	INS-2276, Electrical Schematic
APPENDIX III	INS-2277 (eJP-3) and INS-2573 (eJP-3L), Wiring Diagrams
APPENDIX IV	Deep Cycle Battery Handling, Maintenance and Test Procedures
APPENDIX V	Battery Charger Operating Instructions (eJP-3)
APPENDIX VI	Battery Charger Operator/Installer Manual (eJP-3L)
APPENDIX VII	Honeywell Controller Operating Instructions / Curtis Controller Operating Instructions
APPENDIX VIII	Declaration of Conformity

Parts List Illustration - eJP-3

When ordering replacement parts/kits, please specify model, serial number and color of your unit.

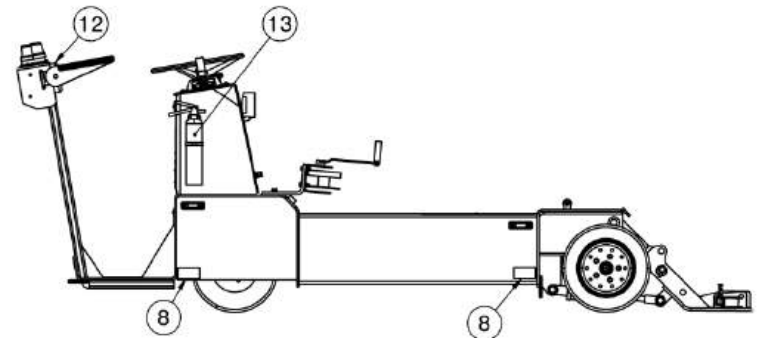
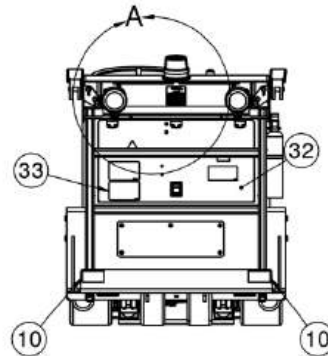
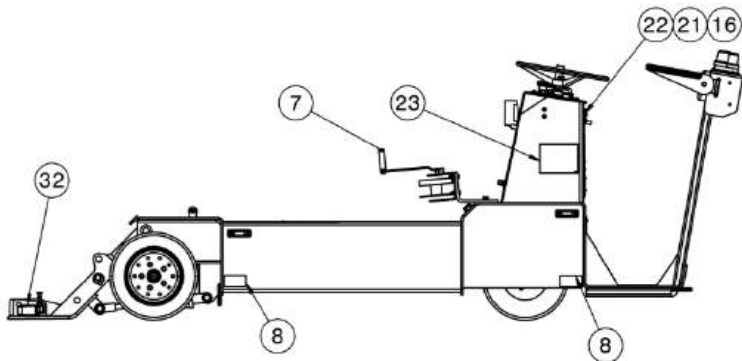
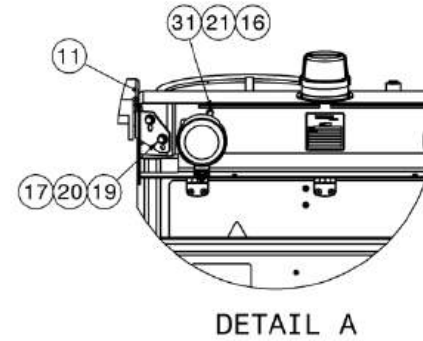
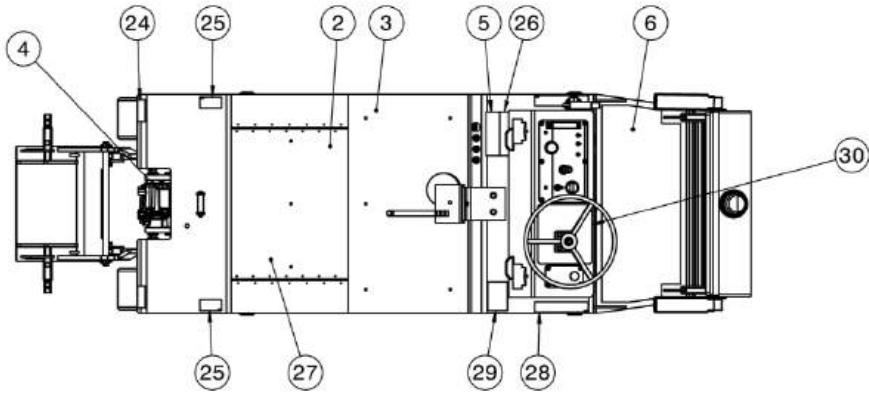

Parts List - eJP-3

When ordering replacement parts/kits, please specify model, serial number and color of your unit.

Item	Part Number	Description	Qty
2	Z-6329	COVER, (MOTOR BAY (COATED)	1
3	Z-6328	ASSY, BATTERY COVER NON-GLARE	1
4	V-2141	LABEL, TRANSMISION SHAFT	1
5	V-2137	LABEL, GROUND POWER UNIT	1
6	H-2948	MAT, PLATFORM	1
7	Z-6307	ASSEMBLY, MANUAL WINCH	1
8	H-2806	REFLECTOR, YELLOW	4
10	H-2807	REFLECTOR, RED	2
11	JP-228	ARM REST	2
12	JP-001	BACKREST, PADDED JP-1	1
13	H-3075	FIRE, EXTINGUISHER	1
16	G-1503-1050N	FLATWASHER. 1/4 SST NARROW	10
17	G-1503-1070N	FLATWASHER. 3/8 SST NARROW	4
19	G-1112-107006	BOLT, 38-16 X 3/4" SST HEX HD	4
20	G-1502-1070R	LOCKWASHER, 3/8 SST REGULAR	4
21	G-1502-1050R	LOCKWASHER, 1/4 SST REGULAR	10
22	G-1476-105006	SCREW, 1/4-20 X 3/4" LG. SST SOC BUTT. HD CAP	6
23	V-2187	LABEL, BATTERY INSTRUCTIONS	1
24	H-2899	TAPE, REFLECTIVE WHITE	2
25	V-2194	LABEL, SIT DOWN	2
26	V-2195	LABEL, GPU	1
27	V-2197	LABEL, USE AW46 OIL	1
28	V-1814	LABEL, WARNING KEEP 5 FT	2
29	V-2188	LABEL, WINCH	1
30	V-2590	LABEL, OP & LOAD INST	1
31	G-1112-105014	BOLT, 1/4-20 X 1-1/2" LG SST HEX HD	4
32	Z-10853	ASSEMBLY CONSOLE PANEL	1
33	V-2826	LABEL, CHARGER INLET 13 AMP	1

Parts List Illustration - eJP-3L

When ordering replacement parts/kits, please specify model, serial number and color of your unit.

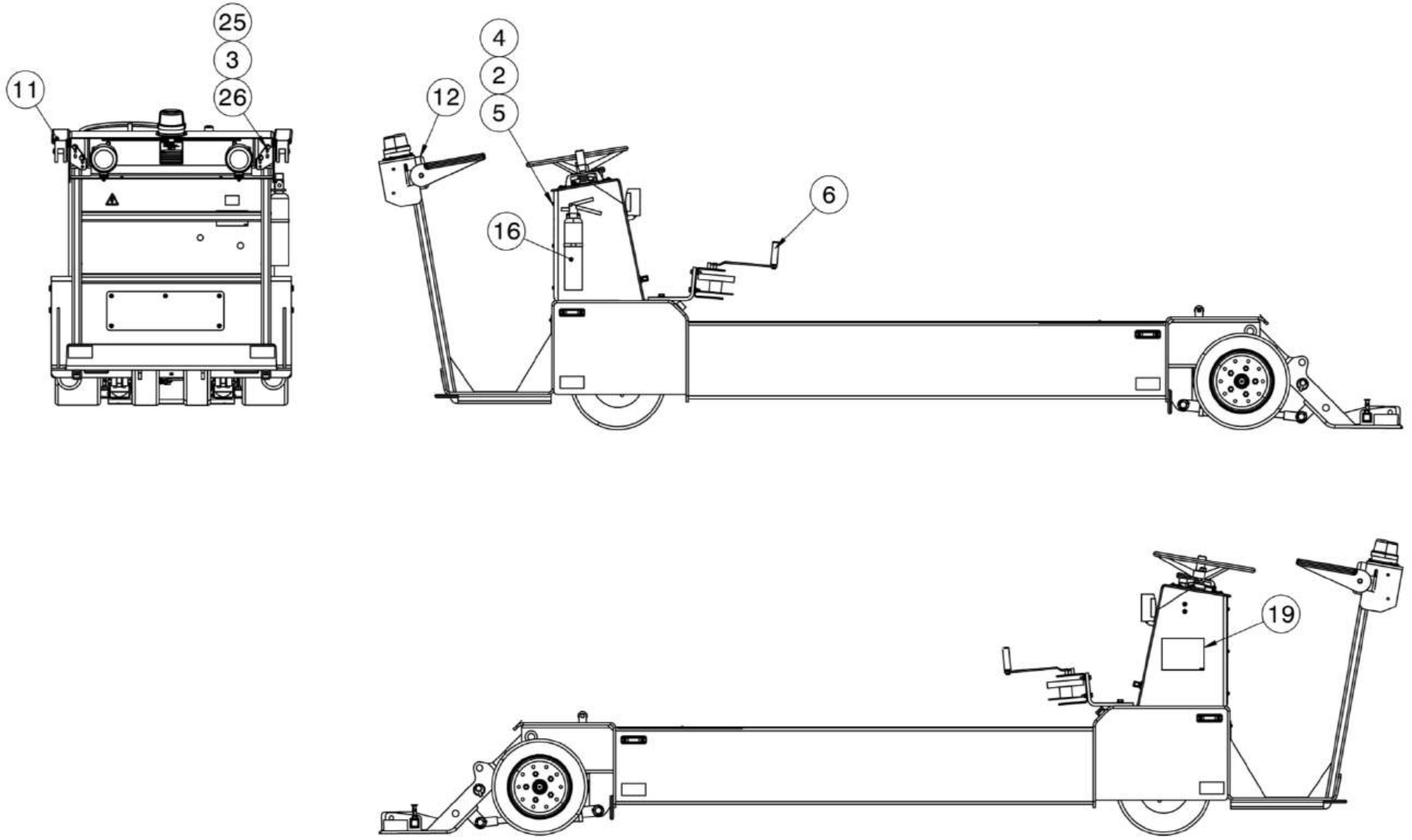

Parts List Illustration - eJP-3L

When ordering replacement parts/kits, please specify model, serial number and color of your unit.

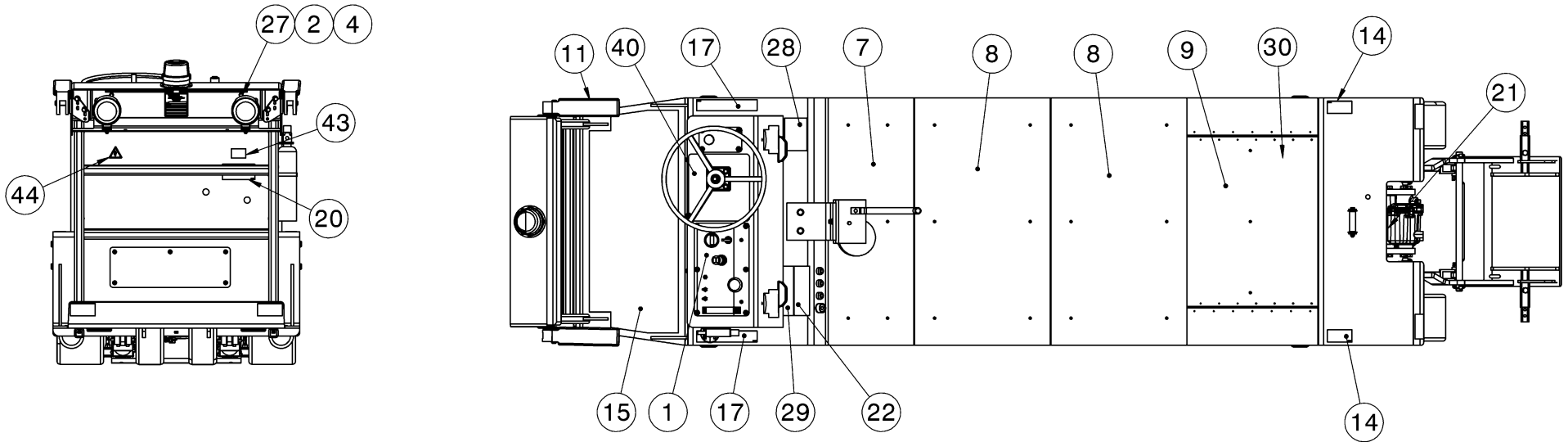

Parts List - eJP-3L

When ordering replacement parts/kits, please specify model, serial number and color of your unit.

Item	Part Number	Description	Qty
1	V-2583	LABEL, CONTROL PANEL	1
2	G-1502-1050R	LOCKWASHER, 1/4 SST REGULAR	10
3	G-1502-1070R	LOCKWASHER, 3/8 SST REGULAR	4
4	G-1503-1050N	FLATWASHER. 1/4 SST NARROW	10
5	G-1476-105006	SCREW, 1/4-20 X 3/4" LG. SST SOC BUTT. HD CAP	6
6	Z-6307	ASSEMBLY, MANUAL WINCH	1
7	Z-6334	ASSY, STORAGE COVER NON-GLARE	1
8	Z-6328	ASSY, BATTERY COVER NON-GLARE	2
9	Z-6329	COVER, (MOTOR BAY (COATED))	1
11	JP-228	ARM REST	2
12	JP-001	BACKREST, PADDED JP-1	1
14	V-2194	LABEL, SIT DOWN	2
15	H-2948	MAT, PLATFORM	1
16	H-3075	FIRE, EXTINGUISHER	1
17	V-1814	LABEL, WARNING KEEP 5 FT	2
19	V-2187	LABEL, BATTERY INSTRUCTIONS	1
20	V-2191	LABEL, CAUTION HAND/FEET	1
21	V-2141	LABEL, TRANSMISION SHAFT	1
22	V-2137	LABEL, GROUND POWER UNIT	1
25	G-1503-1070N	FLATWASHER, 3/8 NARROW S.S.	4
26	G-1112-107006	BOLT, 38-16 X 3/4" SST HEX HD	4
27	G-1112-105014	BOLT, 1/4-20 X 1-1/2" LG SST HEX HD	4
28	V-2188	LABEL, WINCH	1
29	V-2195	LABEL, GPU	1
30	V-2197	LABEL, USE AW46 OIL	1
40	V-2590	LABEL, OP & LOAD INSTRUCTION	1
43	V-1001	LABEL, MADE IN USA	1
44	V-1050	LABEL, ISO ELECTRICAL SHOCK	1

This page left blank intentionally.

Parts List Illustration - eJP-3

When ordering replacement parts/kits, please specify model, serial number and color of your unit.

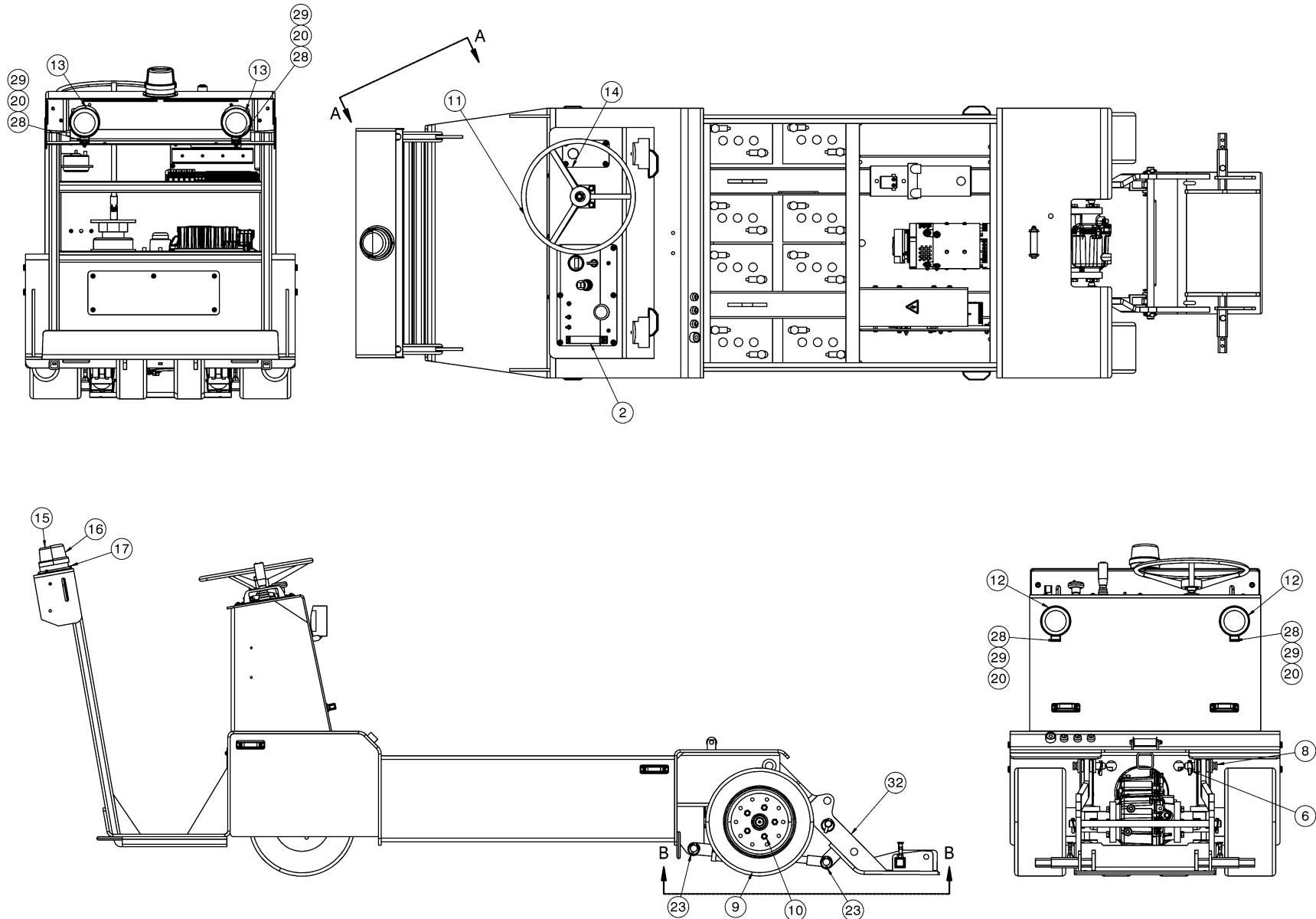

Parts List - eJP-3

When ordering replacement parts/kits, please specify model, serial number and color of your unit.

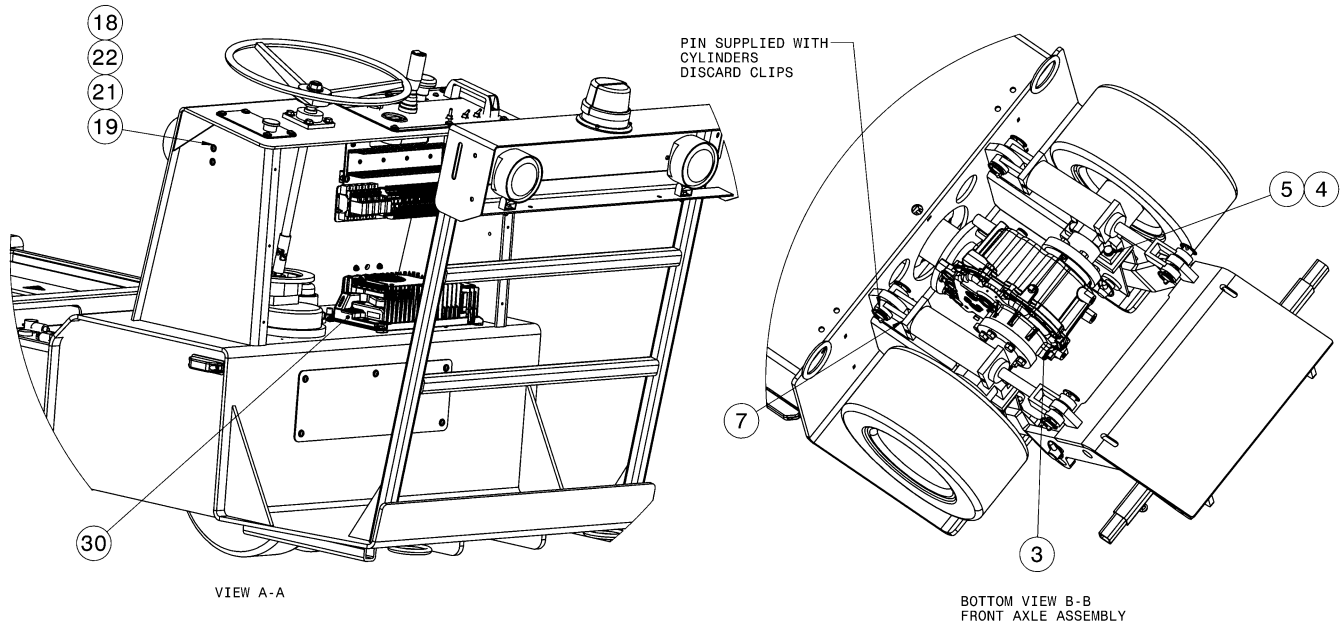

Item	Part Number	Description	Qty
2	Z-8585	ASSEMBLY, CONTROL PANEL	1
3	Z-6271-00	TRANSAXLE ASSEMBLY	1
4	G-1251-1090R	LOCKWASHER, 1/2 REGULAR	4
5	G-1100-109520	BOLT, 1/2-20 X 2.0" HEX HD GR 5	4
6	JP-114	LINCH PIN	2
7	HC-2746	CYLINDER, HYDRAULIC	2
8	JP-104	PIN, LINK 1" X 3" USABLE	2
9	U-1157	TIRE, SOLID RUBBER DRV	2
10	JP-126	FRONT WHEEL HUB NUTS	10
11	Z-6288	ASSEMBLY, STEERING	1
12	EC-2456	LIGHT, WORK SPOT LED	2
13	EC-2456	LIGHT, WORK SPOT LED	2
14	Z-8559	ASSEMBLY, PANEL BRAKE	1
15	JP-118	STOBE, LIGHT	1
16	JP-166	COVER, STROBE LIGHT	1
17	G-1497-102004	SCREW, #8-32 X 1/2" LG SST RD PH	3
18	EC-2011	HORN	1
19	G-1503-1050N	FLATWASHER. 1/4 SST NARROW	4
20	G-1503-1060N	FLATWASHER. 5/16 SST NARROW	8
21	G-1476-105006	SCREW, 1/4-20 X 3/4" LG. SST SOC BUTT. HD CAP	2
22	G-1501-1050	STOPNUT, 1/4-20 ELASTIC S.S.	2
23	G-1320-01	PIN, LYNCH	10
24	EC-2013-01-132	CABLE, 18-2 TYPE SJ00W	1
25	EC-2013-01-142	CABLE, 18-2 TYPE SJ00W	1
26	EC-2013-01-60.0	CABLE, 18-2 TYPE SJ00W	1
27	EC-2013-01-40.0	CABLE, 18-2 TYPE SJ00W	1
28	G-1112-106006	BOLT, 5/16-18 X 3/4 H.H. S.S.	4
29	G-1202-1060	STOPNUT, 5/16-18 ELASTIC	4
30	Z-10855	ASSEMBLY CHARGER EJP-3	1
31	EC-2013-01-152	CABLE, 18-2 TYPE SJ00W	1
32	Z-10860	ASSEMBLY CRADLE	1

Parts List Illustration - eJP-3L

When ordering replacement parts/kits, please specify model, serial number and color of your unit.

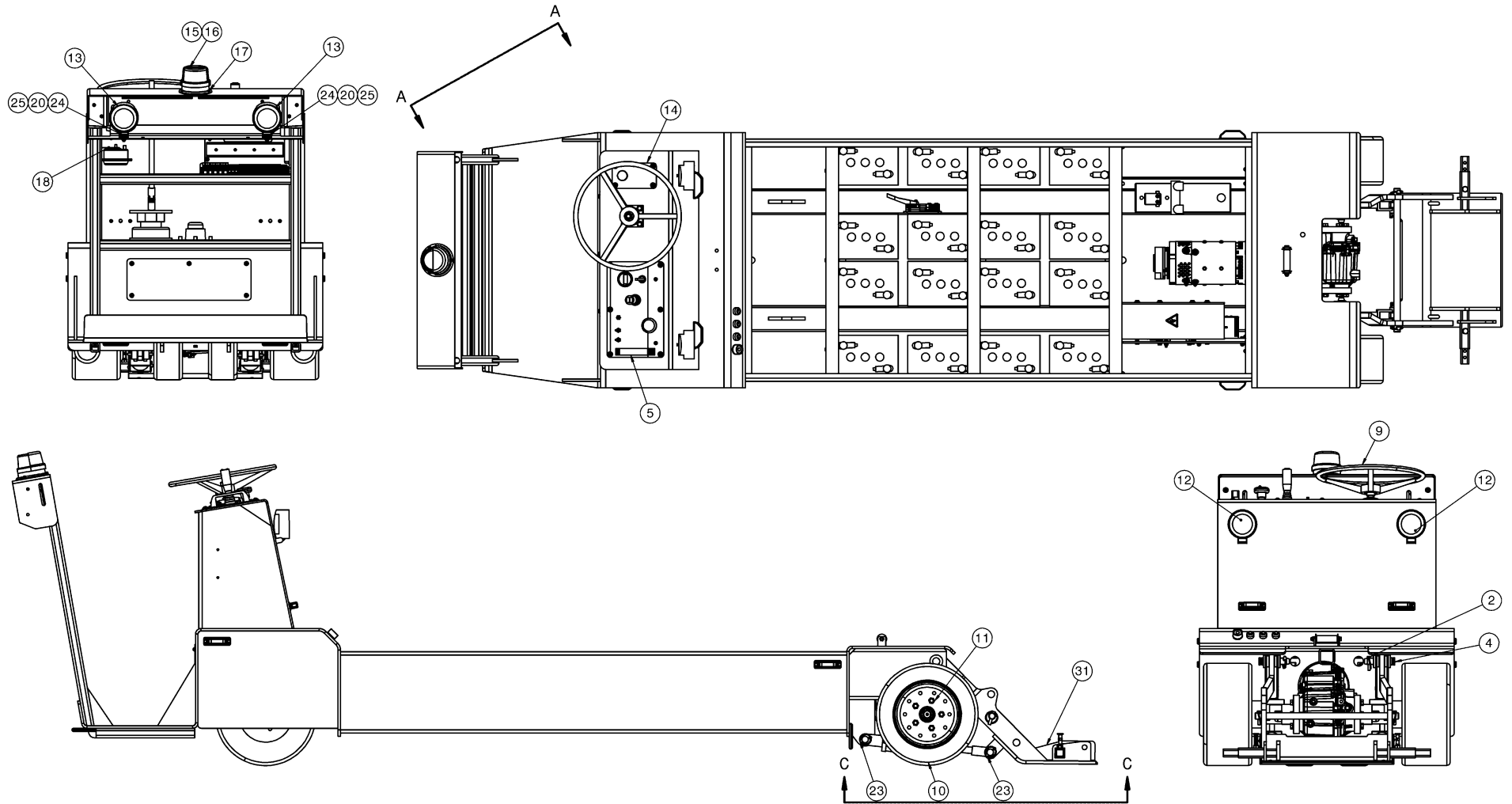

Parts List - eJP-3L

When ordering replacement parts/kits, please specify model, serial number and color of your unit.

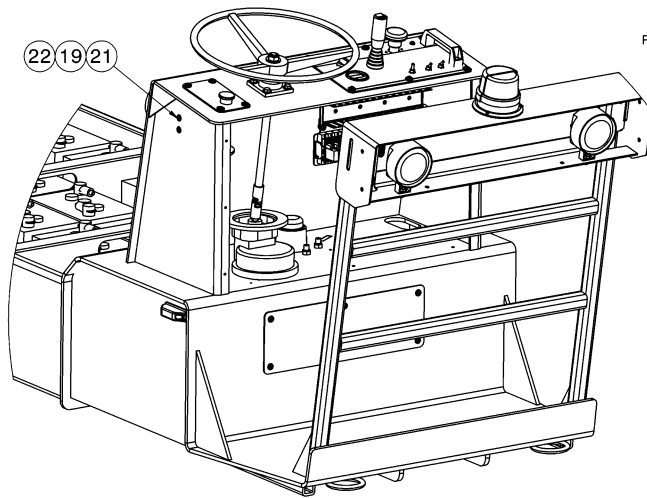

VIEW A-A

PINS SUPPLY WITH
CYLINDERS,
DISCARD CLIPS

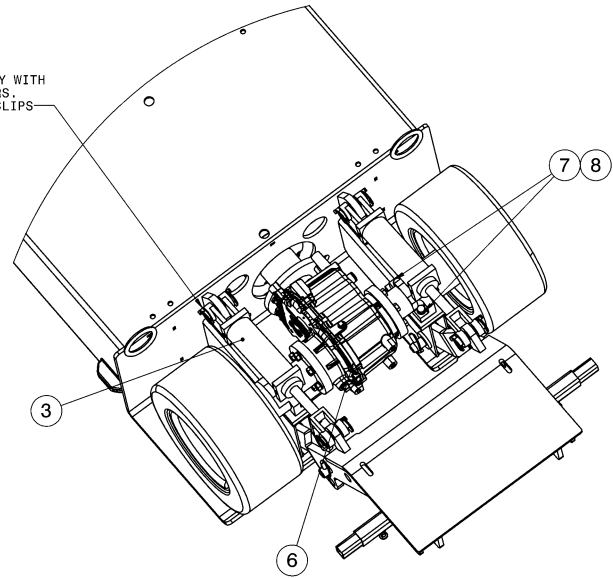

BOTTOM VIEW C-C
FRONT AXLE ASSEMBLY

Item	Part Number	Description	Qty
1	Z-6297	ASSEMBLY, BATTERY BOX EJP-3L	1
2	JP-114	LINCH PIN	2
3	HC-2746	CYLINDER, HYDRAULIC	2
4	JP-104	PIN, LINK 1" X 3" USABLE	2
5	Z-8585	ASSEMBLY, CONTROL PANEL	1
6	Z-6271-01	TRANSAXLE ASSEMBLY	1
7	G-1100-109520	BOLT, 1/2-20 X 2.0" HEX HD GR 5	4
8	G-1251-1090R	LOCKWASHER, 1/2 REGULAR	4
9	Z-6288	ASSEMBLY, STEERING	1
10	U-1157	TIRE, SOLID RUBBER DRV	2
11	JP-126	FRONT WHEEL HUB NUTS	10
12	EC-2456	LIGHT, WORK SPOT LED	2
13	EC-2456	LIGHT, WORK SPOT LED	2
14	Z-8559	ASSEMBLY, PANEL BRAKE	1
15	JP-118	STOBE, LIGHT	1
16	JP-166	COVER, STROBE LIGHT	1
17	G-1497-102004	SCREW, #8-32 X 1/2" LG SST RD PH	3
18	EC-2011	HORN	1
19	G-1503-1050N	FLATWASHER. 1/4 SST NARROW	4
20	G-1503-1060N	FLATWASHER. 5/16 SST NARROW	4
21	G-1476-105006	SCREW, 1/4-20 X 3/4" LG. SST SOC BUTT. HD CAP	2
22	G-1501-1050	STOPNUT, 1/4-20 ELASTIC S.S.	2
23	G-1320-01	PIN, LYNCH	10
24	G-1112-106006	BOLT, 5/16-18 X 3/4 H.H. S.S.	2
25	G-1202-1060	STOPNUT, 5/16-18 ELASTIC	2
26	EC-2013-01-40.0	CABLE, 18-2 TYPE SJ00W	1
27	EC-2013-01-60.0	CABLE, 18-2 TYPE SJ00W	1
28	EC-2013-01-142	CABLE, 18-2 TYPE SJ00W	1
29	EC-2013-01-132	CABLE, 18-2 TYPE SJ00W	1
30	EC-2013-01-152	CABLE, 18-2 TYPE SJ00W	1
31	Z-10860	ASSEMBLY CRADLE	1

Parts List

When ordering replacement parts/kits, please specify model, serial number and color of your unit.

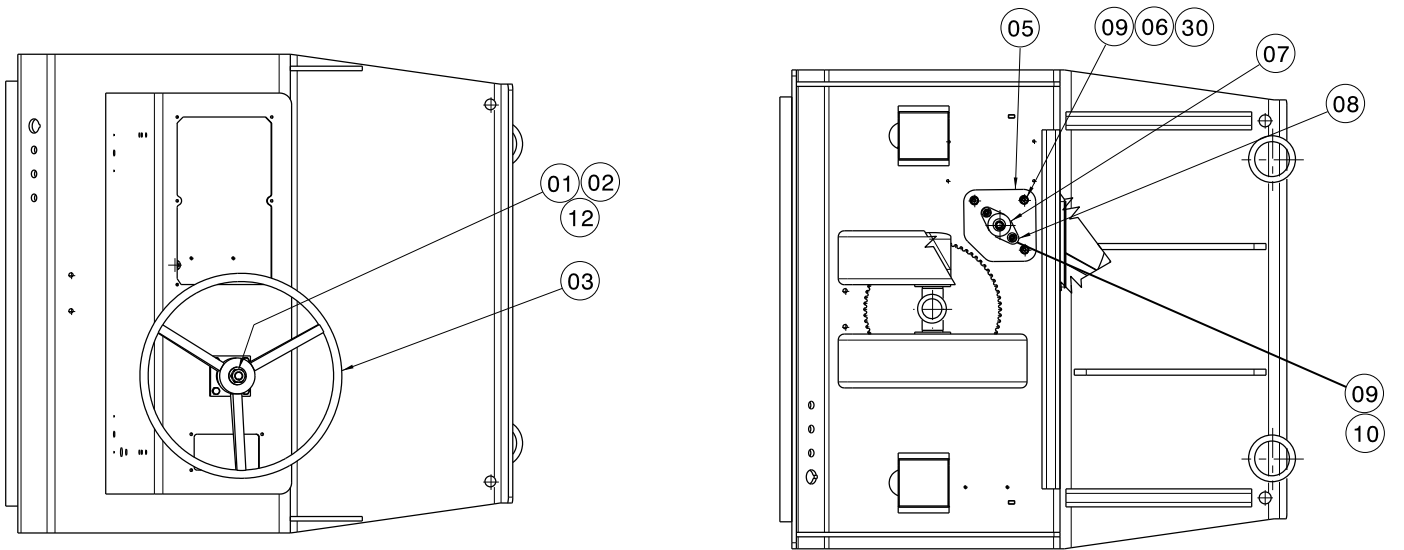

BOTTOM VIEW

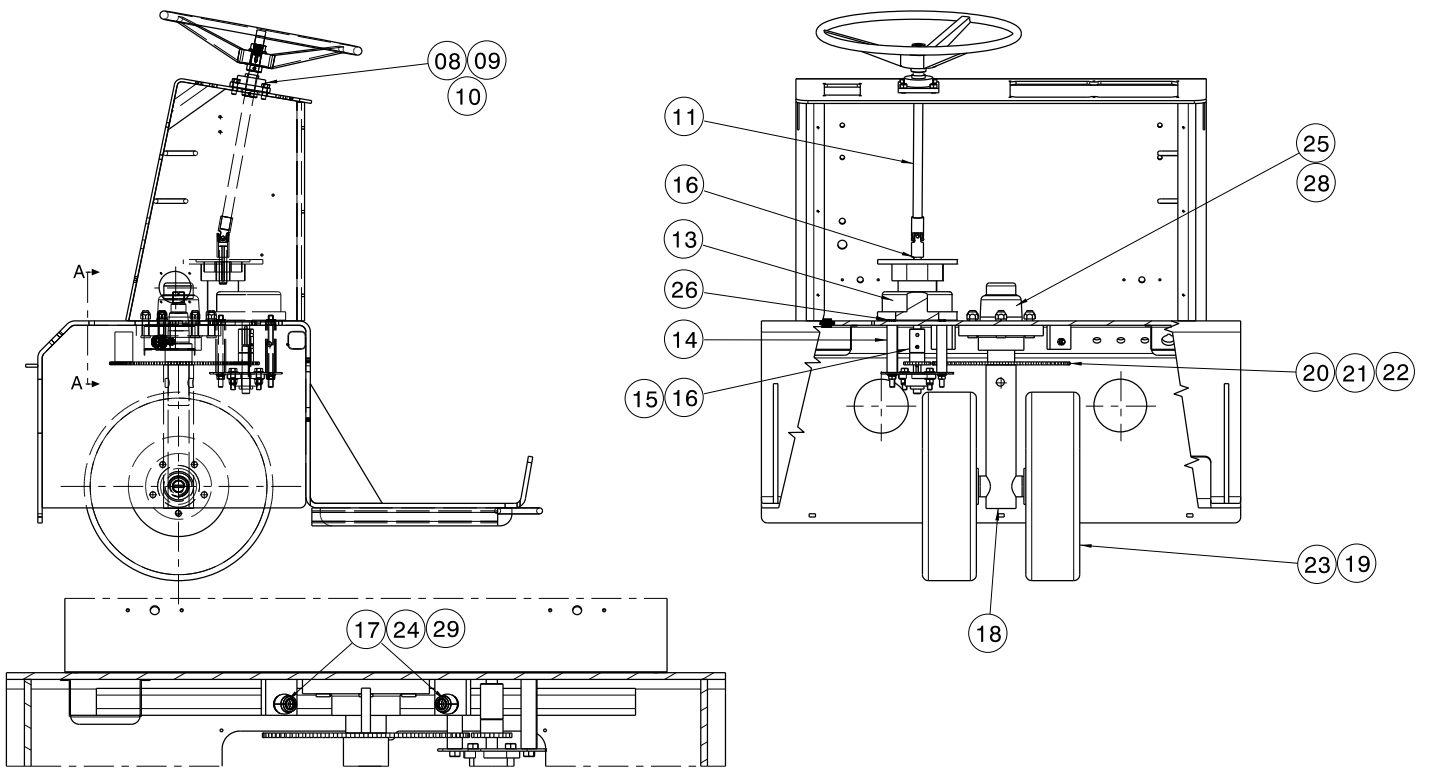

Section view A-A
Scale: 3:16

Parts List

When ordering replacement parts/kits, please specify model, serial number and color of your unit.

Item	Part Number	Description	Qty
1	JP-027	Nut, Stainless (3/4" – 16)	1
2	G-1250-1110N	Flatwasher, Narrow 3/4	1
3	JP-024	Steering Wheel	1
5	S-2111-01	Plate, Bottom	1
6	R016-07*006.00	Rod, STL Plate THD 3/8 - 16	3
7	JP-042	Bearing, Flanged 5/8" Bore	1
8	G-1100-1070N	Bolt, Hex Head, 3/8 – 16 x 1 1/2 Long	6
9	G-1503-1070N	Lockwasher, 3/8 SS	9
10	G-1200-1070	Nut, Hex 3/8– 16	6
11	Z-6268-01	Weldment, Steering Shaft	1
12	J209-01-00.75	Key, 3/16 Sq. x 3/4 Long	1
13	JP-006-01	Multiplier, Ratio	1
14	TR-1968-01	Spacer, Mounting	3
15	Z-6269-01	Weldment, Sprocket	1
16	J209-01*001.50	Key, 3/16 Sq. x 1.5 Long	2
17	H-3803	Spring, Compression	2
18	Z-7019-01	Weldment, Steer Axle	1
19	JP-021	Hub W/Bearings 3500# with Lug Nuts	2
20	JP-020	Chain #40	41 in.
21	JP-113	Link, Half #40 Chain	1
22	JP-110	Link, Master #40 Chain	1
23	JP-060	Wheel, Solid	2
24	G-1154-106212	Screw, 5/16 – 18 Socket Button Head Cap	2
25	H-3200	Hub, With Bearings and Seal	1
26	G-1253-03	Lockwasher, External Tooth	3
28	G-1202-1095	ESN, 1/2 - 20	6
29	G-1202-1060	ESN, 5/16 – 18	2
30	G-1200-1070	Nut, 3/8 - 16 Hex	3

Parts List

When ordering Replacement Parts/Kits, please specify Model, Color and Serial Number of your Unit

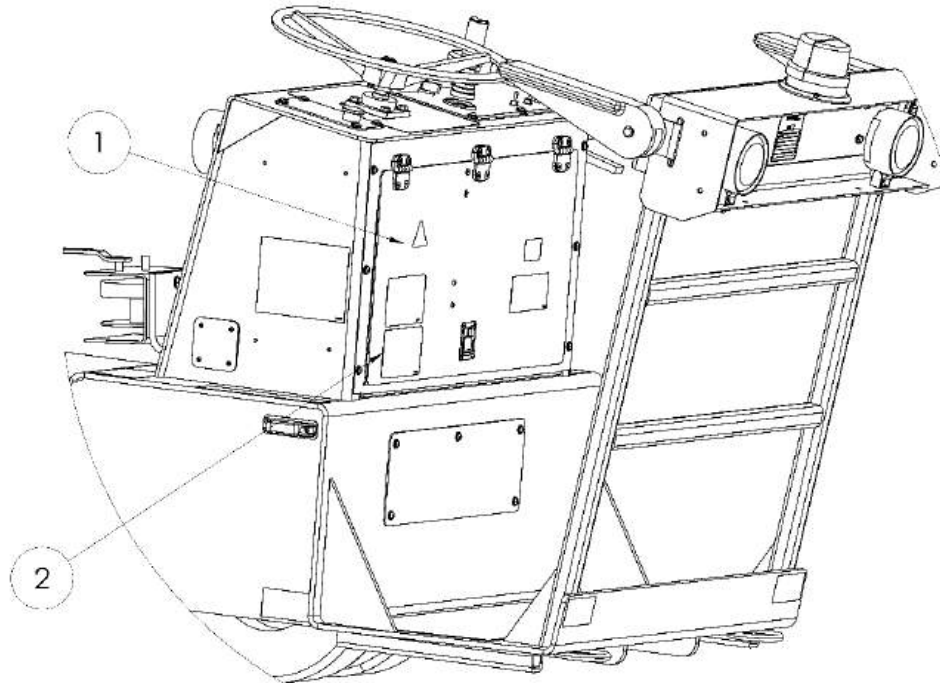

eJP-3

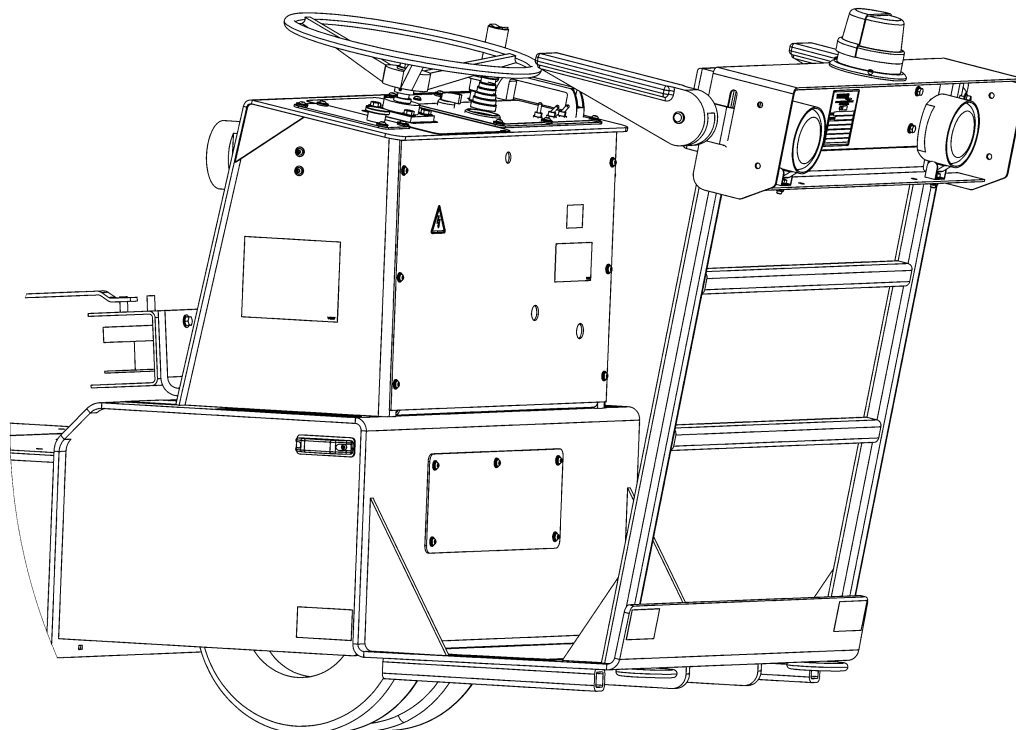

eJP-3L

Item	Part Number	Description	Qty
1	Z-10853	ASSY, CONSOLE PANEL	1
2	V-2826	LABEL, CHARGER INLET 13.4 AMP	1

Parts List

When ordering replacement parts/kits, please specify model, serial number and color of your unit.

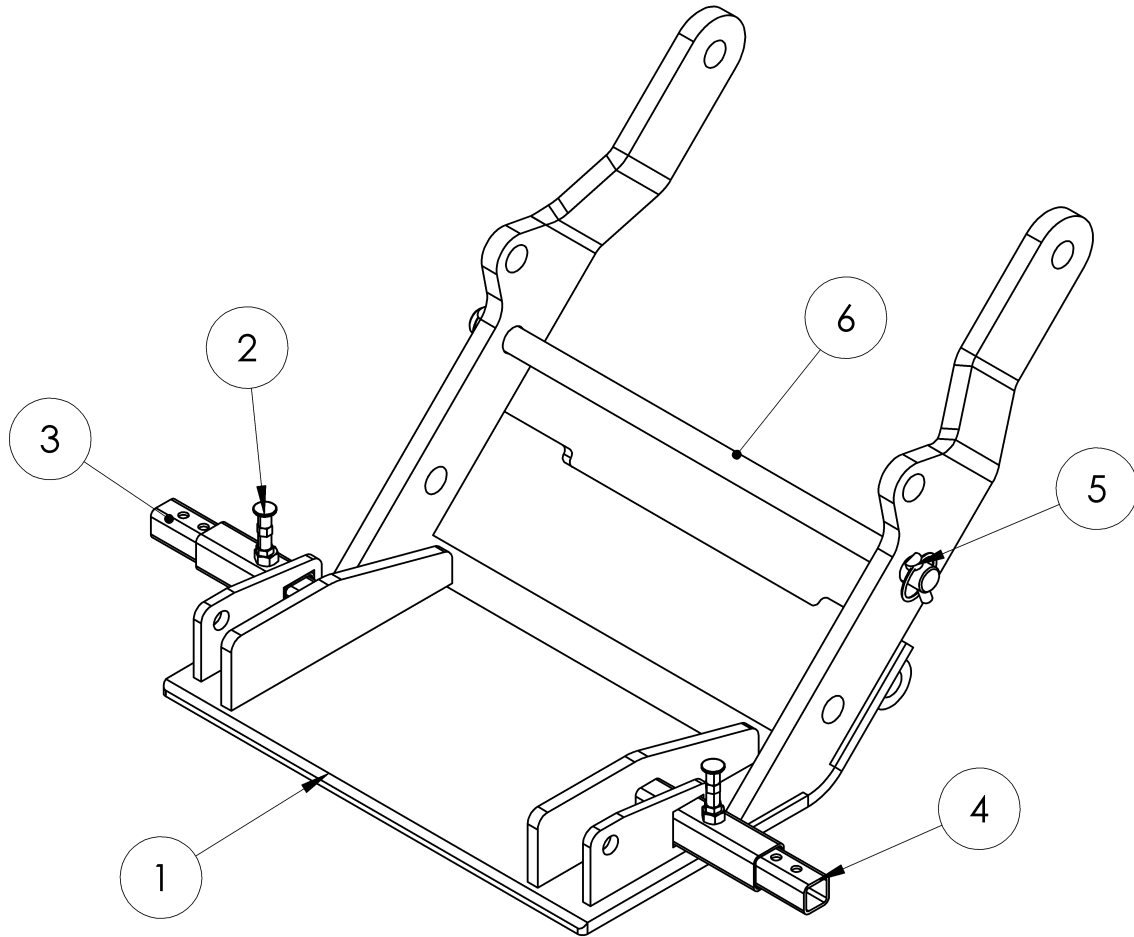

Item	Part Number	Description	Qty
1	Z-10735-00	WELDMENT, LIFT CRADLE	1
2	JP-115	PLUNGER, INDEXING	2
3	Z-10734-00	WELDMENT, TIRE STOP 2	1
4	Z-10733-00	WELDMENT, TIRE STOP 1	1
5	JP-114	LINCH PIN	2
6	R-3265-00	ROD, LIFT CRADLE	1

Parts List – eJP-3 Only

When ordering replacement parts/kits, please specify model, serial number and color of your unit.

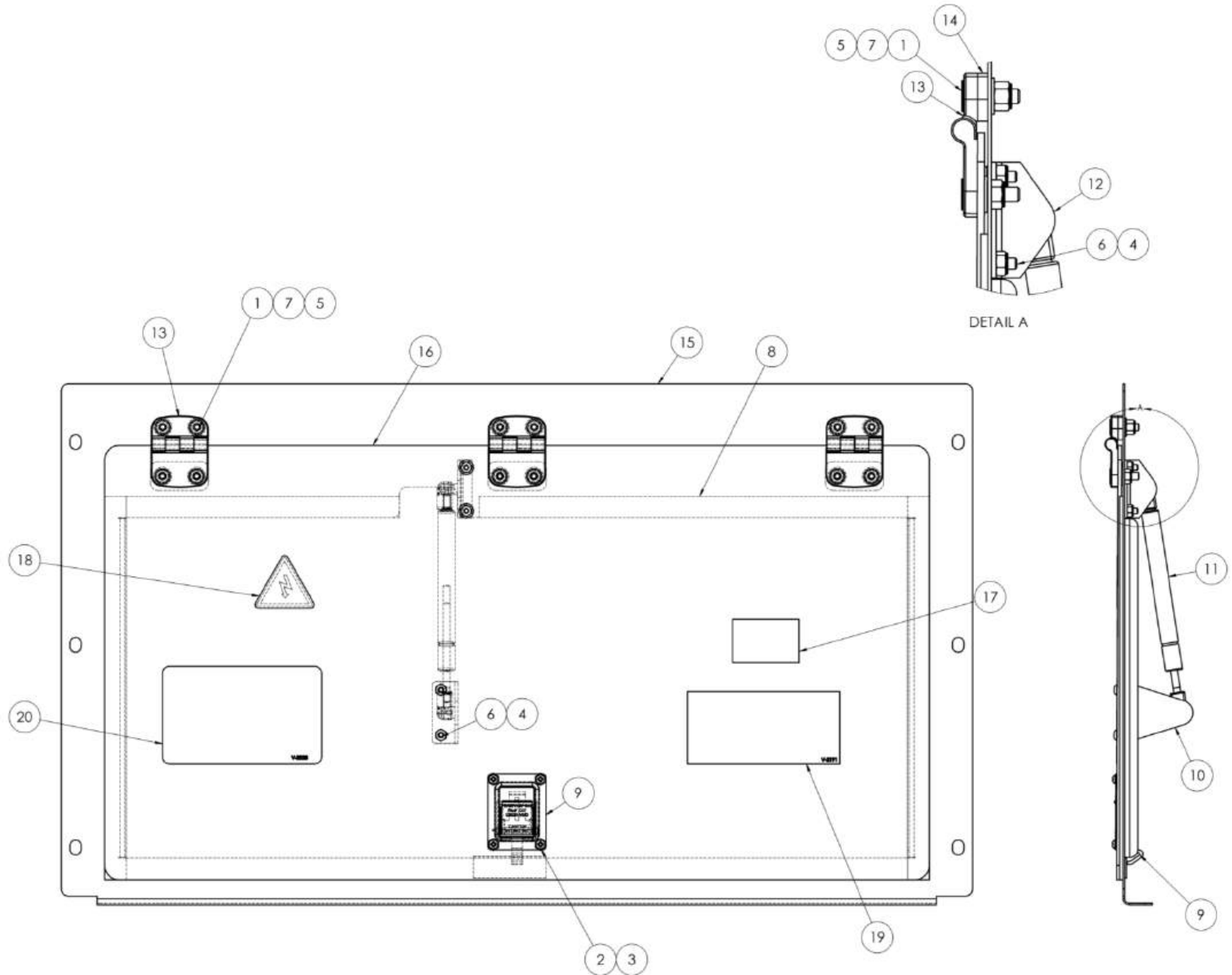

Parts List

When ordering replacement parts/kits, please specify model, serial number and color of your unit.

Item	Part Number	Description	Qty
1	G-1152-105210	SCREW, 1/4-20 X 1.0" LG SOCKET FLAT HD CAP	12
2	G-1159-102004	SCREW, #8-32 X 1/2" LG. RD HEAD CROSS RECESS MACHINE	4
3	G-1202-1020	STOPNUT, #8-32 ELASTIC	4
4	G-1202-1035	STOPNUT, #10-32 ELASTIC	4
5	G-1202-1050	STOPNUT, 1/4-20 ELASTIC	12
6	G-1476-103104	SCREW, #10-32 X 1/2" LG. SST SOC BUTT. HD CAP	4
7	G-1503-1050N	FLATWASHER. 1/4 SST NARROW	12
8	H-1204-06	TAPE, NEOPRENE FOAM SEALING	81 IN
9	H-1207	LATCH, RECESSED	1
10	H-3056	BRACKET 90 DEG W/.390 BALL	1
11	H-4728	GAS, STRUT	1
12	JP-236 BRACKET	BRACKET	1
13	NVSP-24-044-CA, DET A	HINGE	3
14	S-3470-00	SPACER, HINGE (WP)	3
15	S-3841-00	COVER, CONSOLE FRAME	1
16	S-3843-00	PANEL, CONSOLE	1
17	V-1001	LABEL, MADE IN USA	1
18	V-1050	LABEL, ISO ELECTRICAL SHOCK	1
19	V-2191	LABEL, CAUTION HAND/FEET	1
20	V-2828	LABEL, CHARGER VENTILATION DOOR	1

Parts List

When ordering replacement parts/kits, please specify model, serial number and color of your unit.

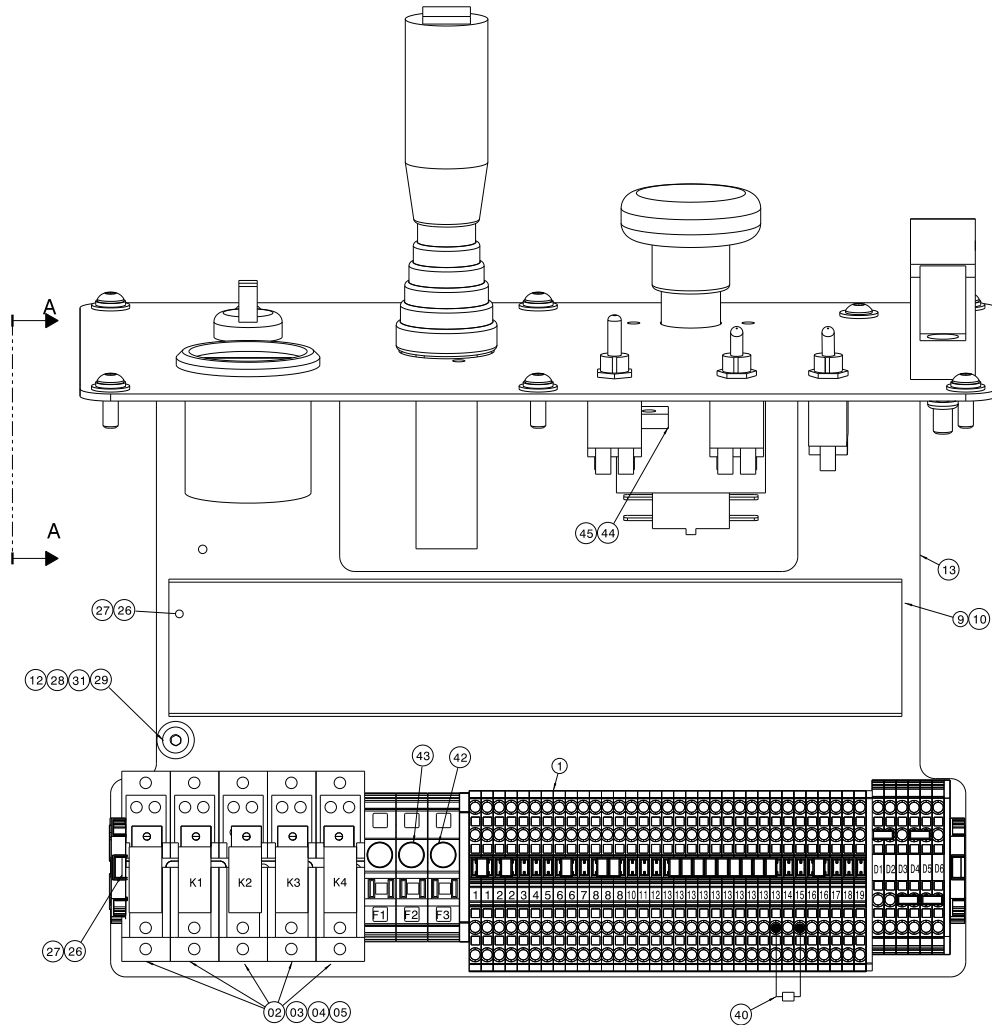

Item	Part Number	Description	Qty
1	EC-2827	Assembly, Din Rail	1
2	EC-2259	Socket, Relay	5
3	EC-2258	Relay	5
4	EC-2260	Relay, Clip	5
5	EC-2060	Diode	5
9	EC-1710-10-12.0	Duct, Wiring	1
10	EC-1711-03-12.0	Covering, Wiring Duct	1
12	EC-2012	Relay, High Capacity	1
13	S-2752-01	Plate, Din Rail	REF
26	G-1476-103004	Screw, 10 - 24 Socket Button Head Cap	8
27	G-1202-1030	ESN, 10 - 24	8
28	G-1476-105006	Screw, 1/4 - 20 Socket Button Head Cap	1
29	G-1503-1050N	Flatwasher, 1/4 Narrow SS	1
31	G-1202-1050	ESN, 1/4 - 20	3
40	4000-34	Resistor, 3K3 OHM 5W 1%	1
44	G-1114-080016	Bolt, Metric M8 Hex Head	2
45	G-1514-M80R	Washer, Split Metric	2
NS	EC-2113-10.00	Replacement Fuse, (10 AMP), use in F1, F3	
NS	EC-2113-5.00	Replacement Fuse, (5 AMP), use in F2	

Parts List

When ordering replacement parts/kits, please specify model, serial number and color of your unit.

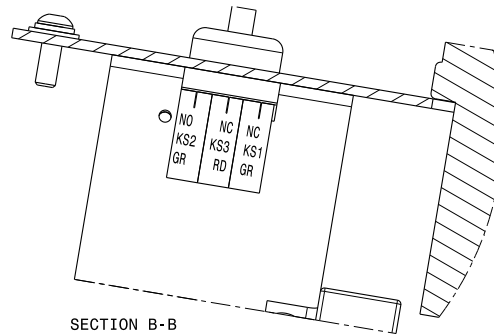
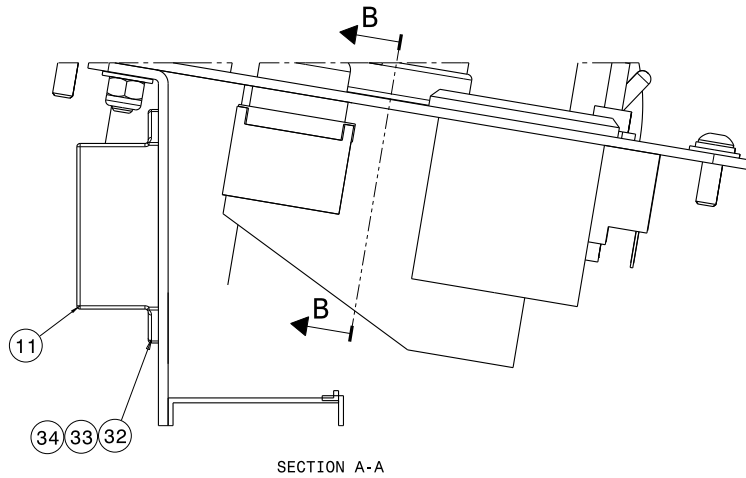

Item	Part Number	Description	Qty
11	EC-2824	Flasher, Solid State 9-32 Volts (for Turn Signal Option)	1
32	G-1157-101504	Screw, Pan HD CRS REC, #6 – 32	2
33	G-1250-1010N	Flatwasher, #6	4
34	G-1202-1010	ESN, #6 – 32	2

Parts List

When ordering replacement parts/kits, please specify model, serial number and color of your unit.

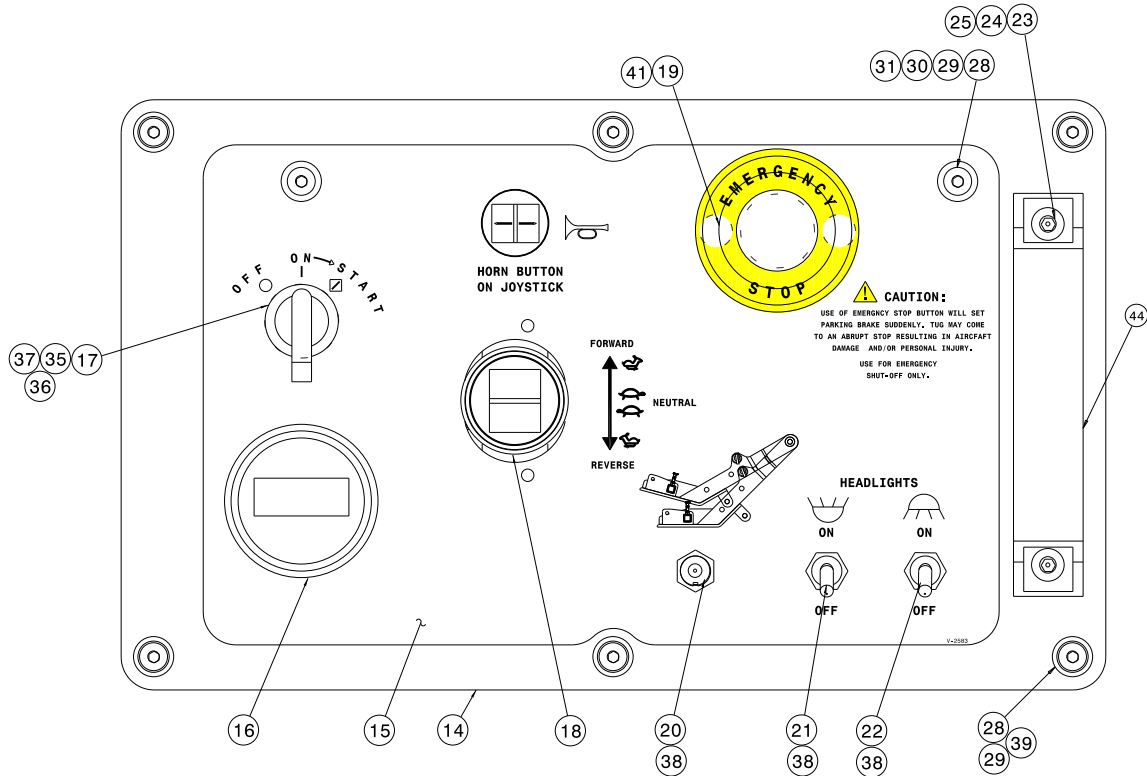

Item	Part Number	Description	Qty
14	S-2751-01	Panel, Accelerator	1
15	V-2583	Label, Control Panel	1
16	EC-2096	Meter, Hour	1
17	EC-2740	Switch, 3 Position Spring R/L	1
18	EC-2334	Joystick	1
19	EC-2831	Switch, E-Stop	1
20	EC-2745	Switch, Toggle 3 Position (DPDT)	1
21	EC-2747	Switch, Toggle 2 Position (DPST)	1
22	EC-2746	Switch, Toggle 2 Position (SPST)	1
23	G-1476-106012	Screw, Hex Socket Button Head Cap	2
24	G-1202-1065	ESN, 5/16 – 24	2
25	G-1503-1060N	Flatwasher, 5/16	2
28	G-1476-105006	Screw, 1/4 - 20 Socket Button Head Cap	8
29	G-1503-1050N	Flatwasher, 1/4 Narrow SS	9
30	G-1502-1050R	Lockwasher, 1/4 SS	2
31	G-1202-1050	ESN, 1/4 - 20	3
35	14142	Flange, Latch	1
36	14143	N.O. Contact Block, Green	1
37	14144	N.C. Contact Block, Red	3
38	EC-2744	Seal, Togglw Switch	3
39	G-1658-13	Washer, w/Neoprene 1/4 Diameter	6
41	EC-2838	Knob, E-Stop Machine	1
44	JP-103	Handle, Grab	1

Parts List

When ordering replacement parts/kits, please specify model, serial number and color of your unit.

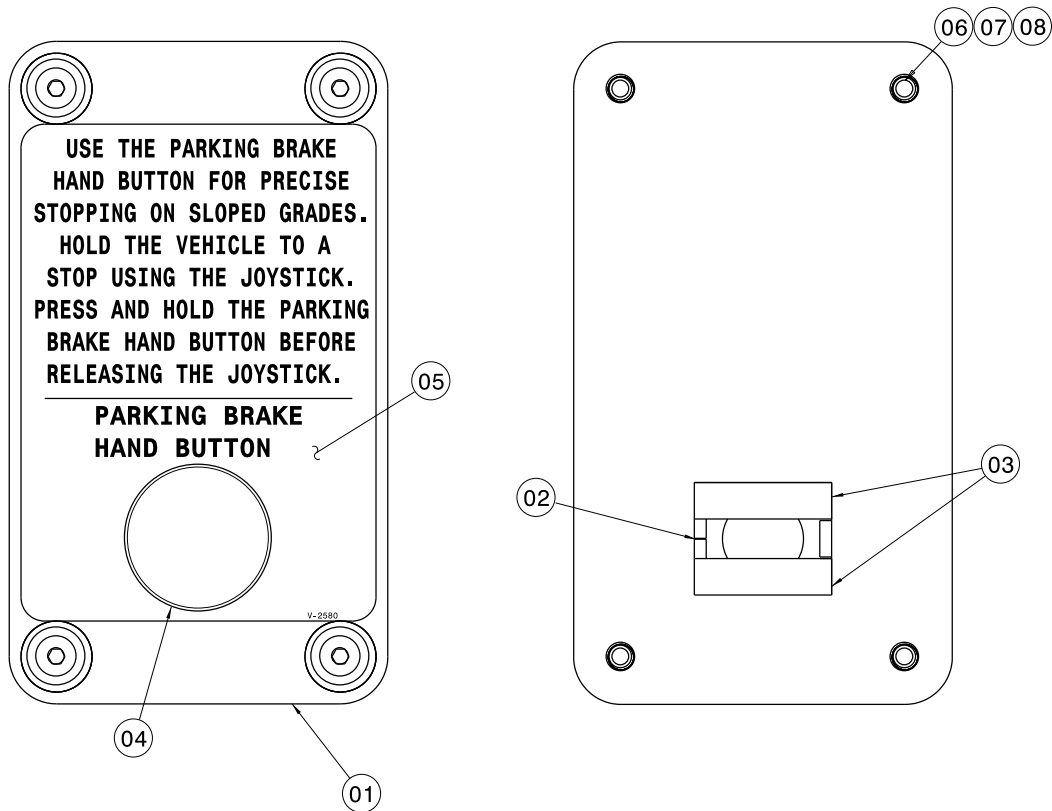

Item	Part Number	Description	Qty
1	S-2747-01	Panel, Switch	1
2	14142	Flange, Latch	1
3	14144	Block, Contact Red	2
4	EC-2817	Switch, Push Button	1
5	V-2580	Label, Panel Brake	1
6	G-1503-1050N	Flatwasher, ¼ Narrow SS	4
7	G-1658-13	Washer, w/Neoprene ¼ Diameter	4
8	G-1476-105010	Screw, ¼ - 20 Socket Button Head Cap	4

Parts List - eJP-3

When ordering replacement parts/kits, please specify model, serial number and color of your unit.

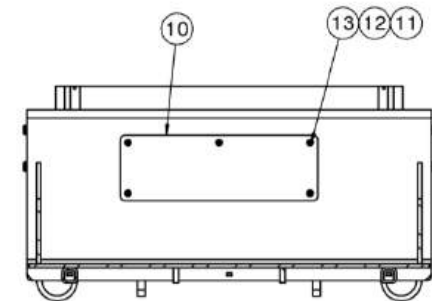
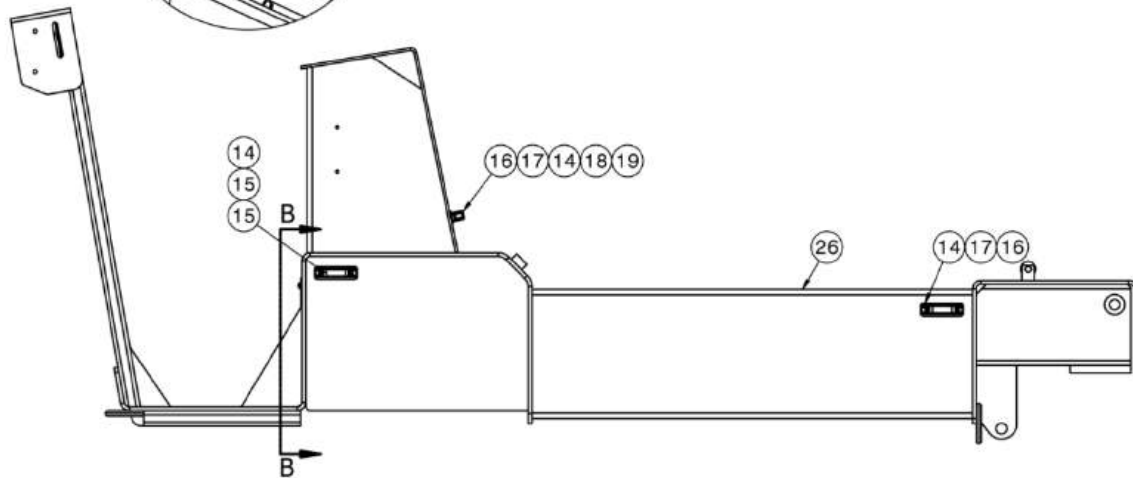
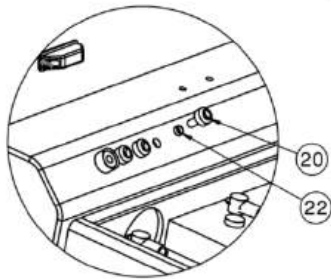
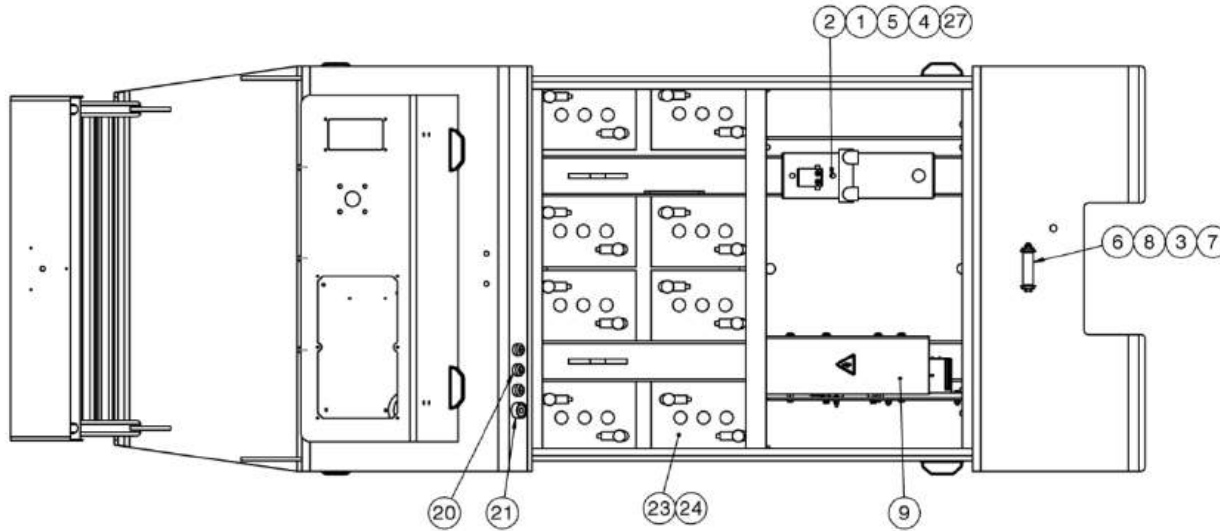

SECTION B-B

Parts List – eJP-3

When ordering replacement parts/kits, please specify model, serial number and color of your unit.

Item	Part Number	Description	Qty
1	JP-003	PUMP, HYDRAULIC	1
2	G-1100-107006	BOLT, 38-16 X 3/4" HEX HD GR 5	2
3	G-1100-107044	BOLT, 38-16 X 4-1/2" HEX HD GR 5	1
4	G-1251-1070R	LOCKWASHER, 3/8 REGULAR	2
5	G-1250-1070N	FLATWASHER, 3/8 NARROW	2
6	TR950-01-003.25	ROLLER	1
7	G-1202-1070	STOPNUT, 3/8-16 ELASTIC	1
8	G-1254-15	WASHER, 3/8 FENDER	2
9	Z-8592	ASSEMBLY, CONTROLLER	1
10	S-2744-01	PANEL, ACCESS	1
11	G-1503-1050N	FLATWASHER. 1/4 SST NARROW	5
12	G-1502-1050R	LOCKWASHER, 1/4 SST REGULAR	5
13	G-1476-105006	SCREW, 1/4-20 X 3/4" LG. SST SOC BUTT. HD CAP	5
14	EC-2709	BASE, BLACK FOR 169 LED LIGHT	6
15	EC-2847	LED 24V RED	2
16	EC-2846	LED 24V AMBER	4
17	G-1476-103110	SCREW, #10-32 X 1.0" LG. SST SOC BUTT. HD CAP	12
18	G-1250-1030N	FLATWASHER, #10	4
19	G-1202-1035	STOPNUT, #10-32 ELASTIC	4
20	JP-033	SOCKET, MILLER WELDING - RED	3
21	EC-2003	SOCKET, FEMALE NEGATIVE	1
22	TR-2030	PLASTIC RING INSULATOR	3
23	JP-058	BATTERIES, T-125 DEEP CYCLE	8
24	EC-2110	BATTERY, TERMINAL INSULATOR	16
25	EC-2865	BATTERY, TERMINAL INSULATOR	6
26	Z-10679-00	WELDMENT, FRAME	1
27	Z-8597	ASSEMBLY, SUPRES DIODE JP30 PMP MTR	1
1	JP-003	PUMP, HYDRAULIC	1
2	G-1100-107006	BOLT, 38-16 X 3/4" HEX HD GR 5	2
3	G-1100-107044	BOLT, 38-16 X 4-1/2" HEX HD GR 5	1
4	G-1251-1070R	LOCKWASHER, 3/8 REGULAR	2

Parts List - eJP-3L

When ordering replacement parts/kits, please specify model, serial number and color of your unit.

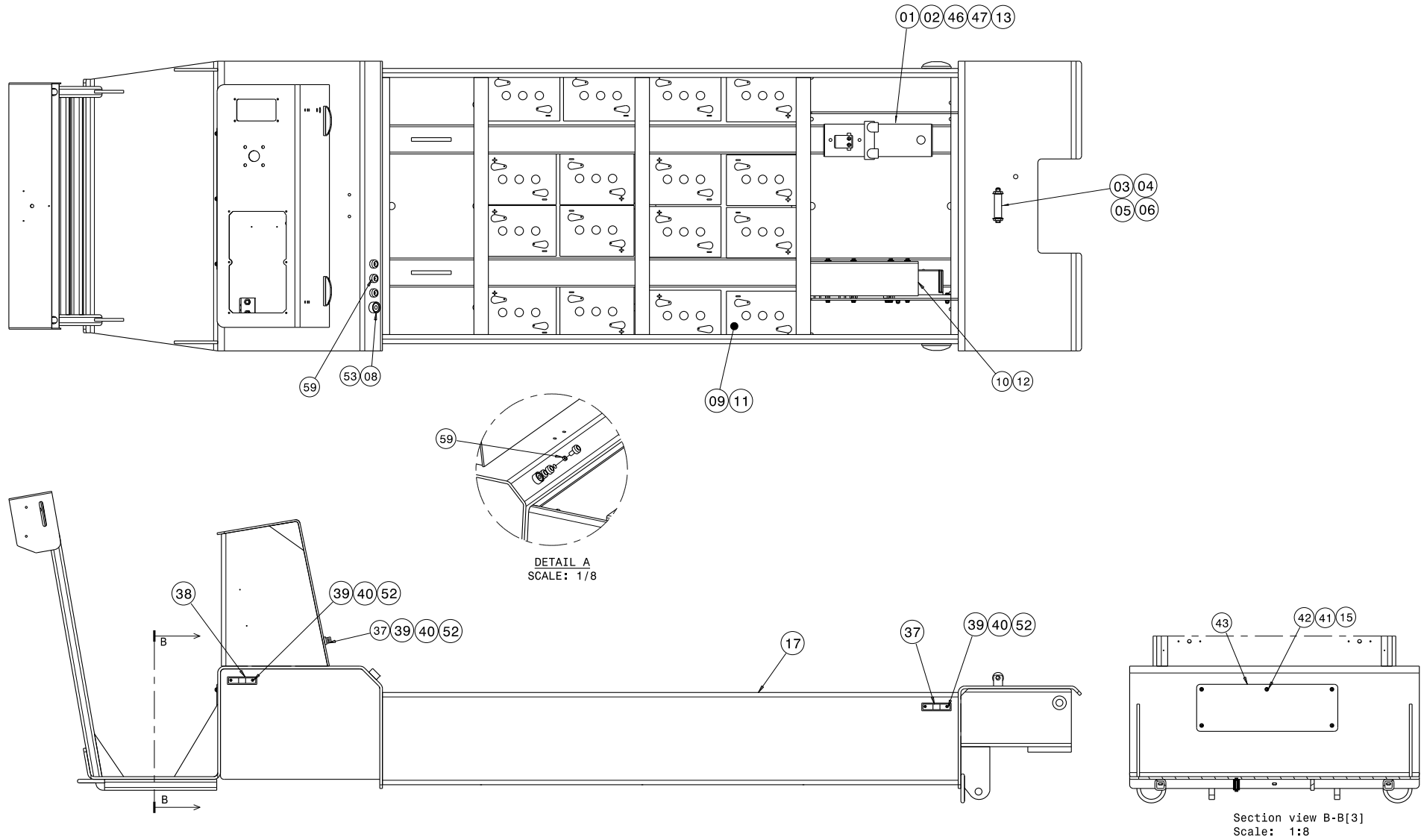

Parts List - eJP-3L

When ordering replacement parts/kits, please specify model, serial number and color of your unit.

Item	Part Number	Description	Qty
1	JP-003	Pump, Hydraulic	1
2	G-1100-107006	Bolt, Hex Head $\frac{3}{8}$ - 16 x $\frac{3}{4}$ Long	2
3	TR950-01*003.25	Roller	1
4	G-1202-1070	ESN, $\frac{3}{8}$ - 16	1
5	G-1100-107044	Bolt, Hex Head $\frac{3}{8}$ - 16 x 4 $\frac{1}{2}$ Long	1
6	G-1254-15	Washer, Fender $\frac{3}{8}$	2
7	JP-033	Socket, Welding	3
8	EC-2003	Socket, Female	1
9	JP-058	Battery, 6V	16
10	Z-8585	Assembly, Controller	1
11	EC-2110	Battery, Terminal Insulator Black	36
12	EC-2837	TSX500 Harness, 11 ft Long	1
13	Z-8597	Assembly, Suppression Diode eJP-3 Pump Motor	1
15	G-1503-1050N	Flatwasher, $\frac{1}{4}$	5
16	EC-2836	Kit, Power Cable	1
17	Z-6296	Frame	REF
37	EC-2707	Assembly, Light Side Marker (Amber)	4
38	EC-2708	Assembly, Light Side Marker (Red)	2
39	G-1476-103110	Screw, 10 – 32 1.0 Socket Button Head Cap	12
40	G-1250-1030N	Flatwasher, #10	12
41	G-1476-105006	Screw, $\frac{1}{4}$ - 20 Socket Button Head Cap	5
42	G-1502-1050R	Lockwasher, $\frac{1}{4}$ Regular	5
43	S-2744-01	Panel Access	REF
46	G-1251-1070R	Lockwasher, $\frac{3}{8}$ Regular	2
47	G-1250-1070N	Flatwasher, $\frac{3}{8}$ Narrow	2
52	G-1202-1035	ESN, #10 – 32	8
53	TR1048*0.125	TBG, Silicone Rubber	1
58	G-1502-1050R	Lockwasher, $\frac{1}{4}$ SS	4
59	TR-2030	Ring, Plastic Insulator	3
NS	H-2990	Trim, Vinyl	62"

Hydraulics Assembly

When ordering replacement parts/kits, please specify model, serial number and color of your unit.

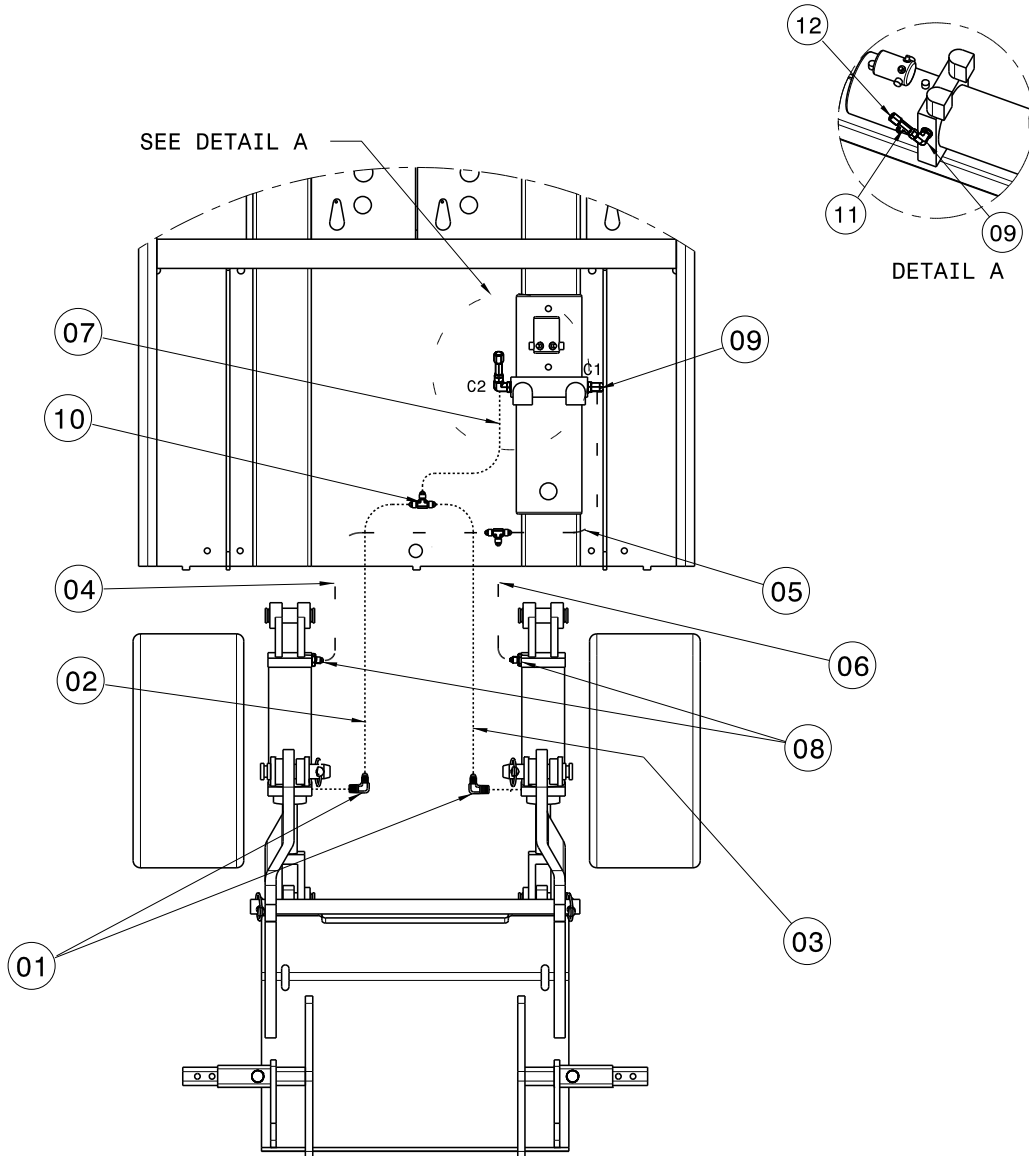

Item	Part Number	Description	Qty
1	N-2001-06-S-B	Elbow, Straight Thread	2
2	TF-1037-28*30.0	Assembly, Hose	1
3	TF-1037-28*20.0	Assembly, Hose	1
4	TF-1037-27*16.0	Assembly, Hose	1
5	TF-1037-28*15.0	Assembly, Hose	1
6	TF-1037-27*14.0	Assembly, Hose	1
7	TF-1037-28*13.0	Assembly, Hose	1
8	N-2007-06-S-B	Connector, Straight Thread	2
9	N-2001-05-S-B	Elbow, ¼ Tube x 09 Straight Thread	2
10	N-2012-03-S	Tee, Union	2
11	N-2016-03-S	Tee, Run Swivel	1
12	N-2008-S	Cap. ¼	1

This page left blank intentionally.

Axle Assembly

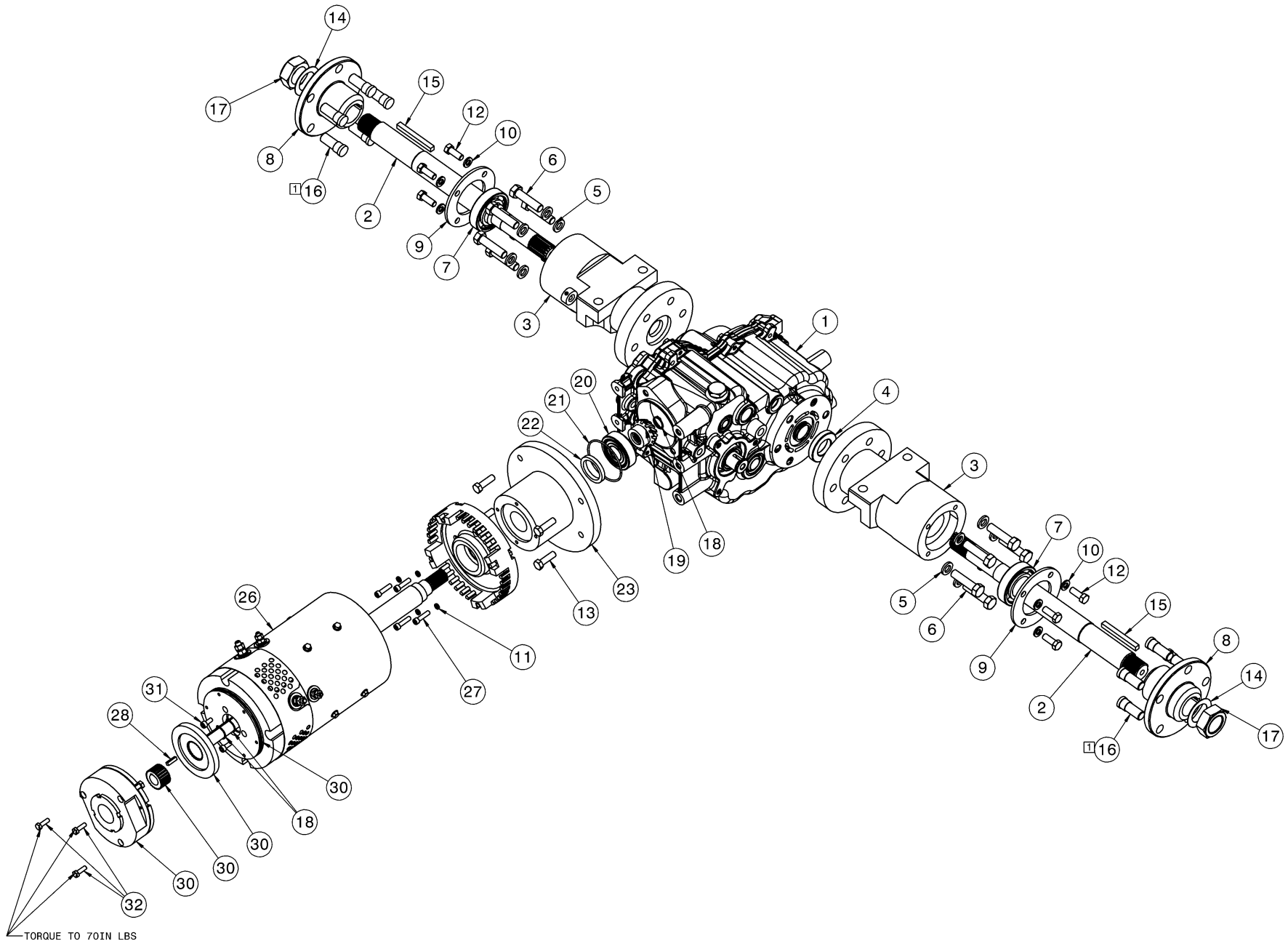

Parts List – Axle Assembly

When ordering replacement parts/kits, please specify model, serial number and color of your unit.

Item	Part Number	Description	Qty
1	JP-054	TRANSAXLE, PEERLESS 2 SPEED	1
2	R-3106	ROD, AXLE	2
3	Z-9939	AXLE HOUSING	2
4	JP-117	PEERLESS AXLE HOUSING RING	2
5	G-1251-1090R	LOCKWASHER, 1/2 REGULAR	12
6	G-1100-109020	BOLT, 1/2-13 X 2.00" HEX HD GR 5	12
7	H-4172	DP GRV BALL BEARING 2.84 X 1.38	2
8	R-3160	WHEEL HUB	2
9	S-3257-00	PLATE, BEARING RETAINER (P)	2
10	G-1251-1070R	LOCKWASHER, 3/8 REGULAR	8
11	G-1251-1050HC	LOCKWASHER, 1/4 HIGH COLLAR	4
12	G-1100-107010	BOLT, 3/8-16 X 1.0" HEX HD GR 5	8
13	G-1100-107012	BOLT, 3/8-16 X 1-1/4" HEX HD GR 5	4
14	95229A910	WASHER, 1-5/16 AN	2
15	J213-01-003.00	KEYSTOCK STL .3125-.3125	2
16	JP-074	WHEEL HUB STUD DICO	10
17	G-1203-1135	JAMNUT, 1-1/4-12 ELASTIC	2
18	G-1392-75-S	RING, EXTERNAL RETAINING	3
19	JP-056	PINION, PEERLESS DRIVE	1
20	JP-080	BEARING, DOUBLE SEALED	1
21	HC-2000-149	O-RING, SERIES 2	1
22	JP-082	SEAL, SHAFT	1
23	JP-008	MOTOR ADAPTOR	1
24	JP-026	SHAFT COLLAR 1/2"	1
25	G-1163-13	SCREW, 1/4-20 X 3/4" LG. HEX CUP PT SET	1
26	EC-2094	6 HP MOTOR SEPARATELY EXCITED	1
27	G-1151-105210	SCREW, 1/4-20 X 1.0" LG SOCKET HD CAP	4
28	J209-01-00.75	KEYSK, STL .187-.187	1
29	N-2206-06-S	PLUG, HEX HEAD	1
30	JP-004	BRAKE, ELECTRIC	1
31	G-1491-106082	SCR, M6-1.0 X 14MM HD CAP	3
32	G-1114-060020	BOLT, M6X1.0 X 20 CLASS 8.8	3

Parts List – Cables

When ordering Replacement Parts/Kits, please specify Model & Serial Number of your product.

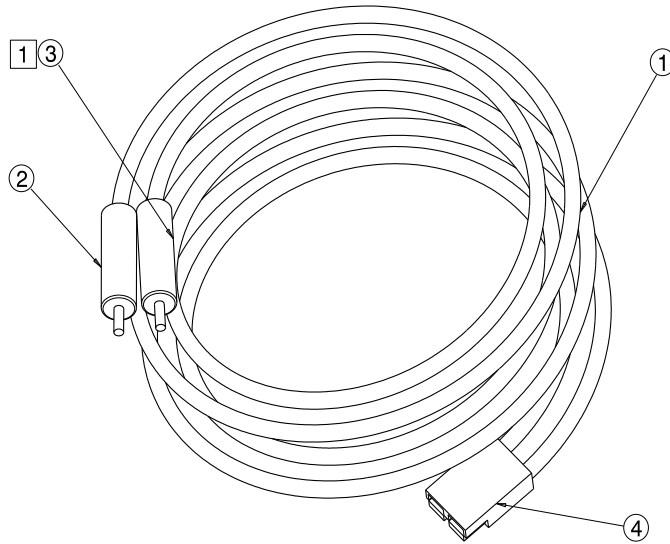

Z-6585 CABLE ASSEMBLY

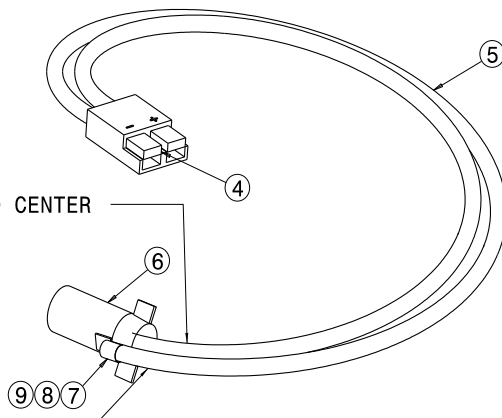

POSTIVE (+) END CENTER OF ITEM 6

Z-6303 ASSEMBLY, CABLE PIPER

NEGATIVE (-) END BOLTS TO OUTSIDE OF ITEM 6

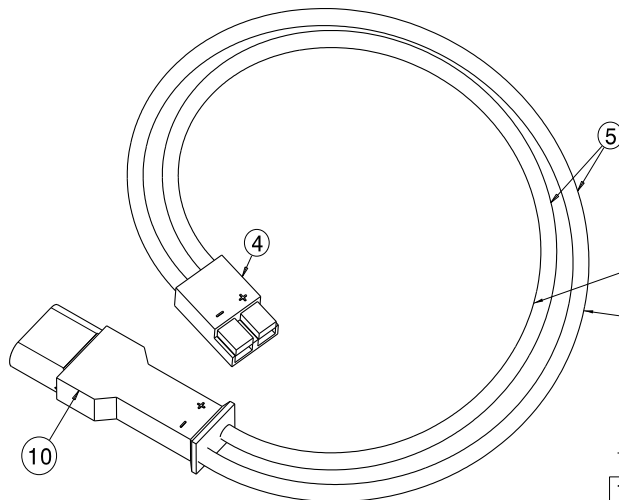

Z-6304 ASSEMBLY, CABLE CESSNA

MATCH POSTIVE (+) TO POSTIVE (+) OF ITEM 10 & 4

MATCH NEGATIVE (-) TO NEGATIVE (-) OF ITEM 10 & 4

INSTRUCTIONS

- 1 CABLE WITH ITEM 3 (RED PLUG) MUST BE CONNECTED TO POSTIVE TERMINAL OF ITEM 4 (CONNECTOR)

Parts List – Cables

When ordering replacement parts/kits, please specify model, serial number and color of your unit.

Item	Part Number	Description	Qty
1	EC-1185-04*144	Cable, Welding 1/0	2
2	EC-2004	Plug, Male Negative (Black)	1
3	JP-031	Plug, Male Positive (Red)	1
4	JP-105	Gray HPU Connector	3
5	EC-1185-04*24.0	Cable, Welding 1/0	4
6	JP-037	Piper APU Plug	1
7	EC-1057-01	Heat Shrink	1
8	EC-1034-07	Terminal, Ring	1
9	G-1100-105004	Bolt, Hex Head Grade 5	1
10	JP-038	Cessna APU Plug	1
For complete cable replacement order:			
	Z-6585	Cable Assembly; consists of:	
1	EC-1185-04*144	Cable, Welding 1/0	2
2	EC-2004	Plug, Male Negative (Black)	1
3	JP-031	Plug, Male Positive (Red)	1
4	JP-105	Gray HPU Connector	1
	Z-6303	Piper Cable Assembly; consists of:	
4	JP-105	Gray HPU Connector	1
5	EC-1185-04*24.0	Cable, Welding 1/0	2
6	JP-037	Piper APU Plug	1
7	EC-1057-01	Heat Shrink	1
8	EC-1034-07	Terminal, Ring	1
9	G-1100-105004	Bolt, Hex Head Grade 5	1
	Z-6304	Piper Cable Assembly; consists of:	
4	JP-105	Gray HPU Connector	1
5	EC-1185-04*24.0	Cable, Welding 1/0	2
10	JP-038	Cessna APU Plug	1

**Parts List
REPLACEMENT STRAPS**

Part Number	Description	Qty
JP-069	Winch Strap	1
JP-090	Safety Strap	1
JP-065	2" Strut Strap (31")	1

**Parts List
REPLACEMENT LABELS**

Part Number	Description	Qty
V-2141	Transmission Shaft	1
V-2137	Ground Power Unit	1
V-2590	Operation & Loading Instructions	1
V-2733	eJP-3	2
V-2734	eJP3L	2
V-2118	Serial Number CE	1
V-2187	Battery Instructions	1
V-2195	Ground Power Unit	1
V-2194	Sit Down	2
V-2188	Winch	1
V-2197	Use AW46 Oil	1
V-2191	Caution Hands/Feet	1
V-1814	Warning Keep 5 Ft Clear	2
V-2580	Label, Brake Panel	1
V-2583	Label, Control Panel	1
V-2579	Label, Signal Panel (Turn Signal Option Only)	1

This page left blank intentionally

Parts List

When ordering replacement parts/kits, please specify model, serial number and color of your unit.

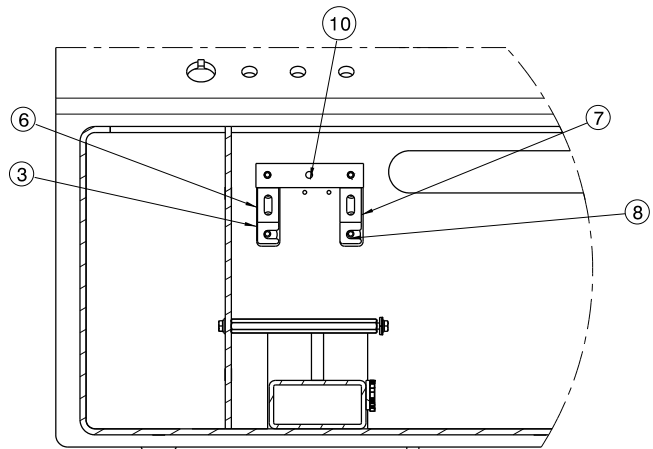
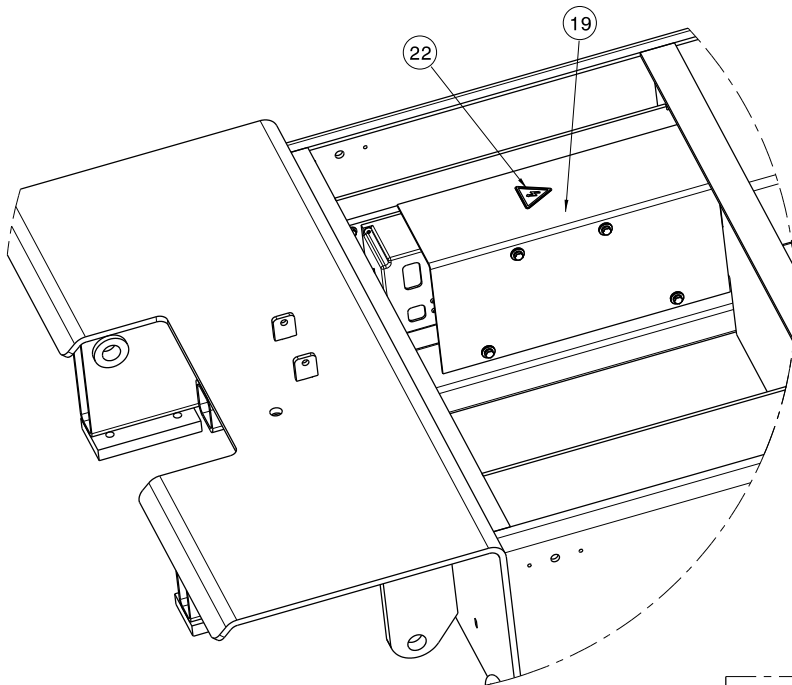

Section view A-A
Scale: 1:4

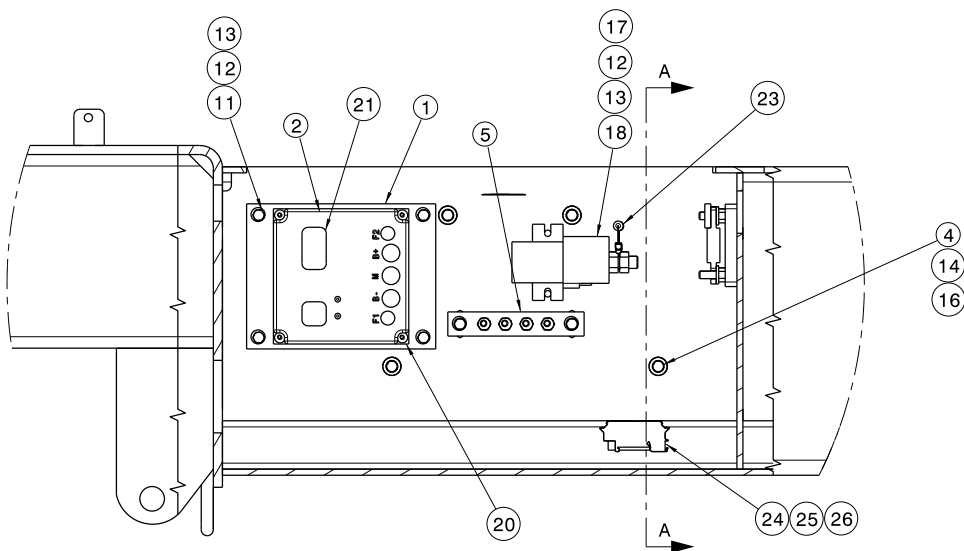

Parts List

When ordering replacement parts/kits, please specify model, serial number and color of your unit.

Item	Part Number	Description	Qty
1	J-5815	Plate, Heat Shrink	1
2	EC-2090	Controller	1
3	EC-1618	Fuse Block, ANL Limiters	2
4	H-3808	Standoff, Female Thread 5 Long	4
5	Z-7949	Assembly, Negative Buss Bar	1
6	EC-1619-18	Fuse, Low Voltage Limiter 400 A	1
7	EC-1619-04	Fuse, Low Voltage Limiter 60 A	1
8	G-1152-103712	Screw, Socket Flat Head 10-32	4
10	J-5189	Bar, Buss	1
11	G-1100-105012	Bolt, Hex Head Grade 5, 1/4 - 20 x 1.25 Long	4
12	G-1503-1050N	Flatwasher, 1/4 SS	10
13	G-1202-1050	ESN, 1/4 - 20	6
14	G-1658-13	Washer, Neoprene, 1/4	4
15	G-1502-1050R	Lockwasher, 1/4 Regular	8
16	G-1100-15006	Bolt, Hex Head Grade 5, 1/4 - 20 x 3/4 Long	8
17	G-1476-105010	Screw, Socket Button head Cap, 1/4 - 20	2
18	EC-2825	Contactora, 48 VDC SPST NO	1
19	S-2753	Cover, Controller	1
20	G-1154-105206	Screw, Socket Button head Cap, 1/4 - 20	4
21	EC-2837	TSX500 Harness, 11 ft	1
22	V-1050	Label, ISO Electrical Shock	1
23	Z-9545	Assembly, Resistor 250 OHM	1
24	EC-2408	Terminal, Block Diode 4 Cond	1
25	EC-2411	Plate, End Diode Block	1
26	H-2973	Tape, Polyurethane Foam Seal	2"

Parts List

When ordering replacement parts/kits, please specify model, serial number and color of your unit.

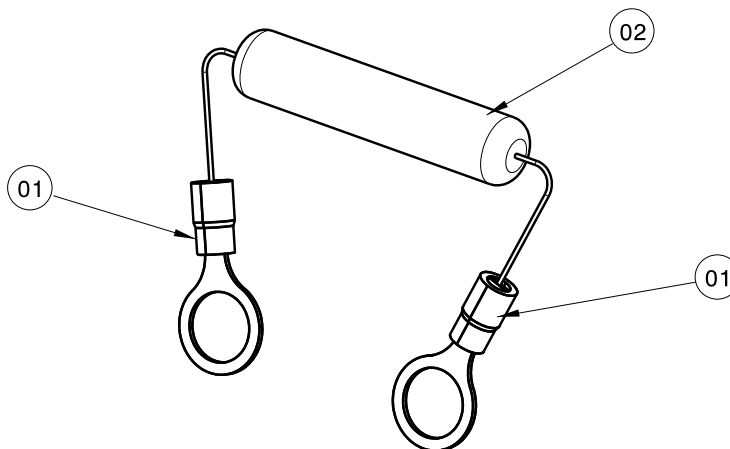

Item	Part Number	Description	Qty
1	EC-1180-13	Terminal, Ring Tongue	2
2	EC-2880	Resistor, 250 OHM 10 W	1

Parts List – Turn Signal Kit Option

When ordering replacement parts/kits, please specify model, serial number and color of your unit.

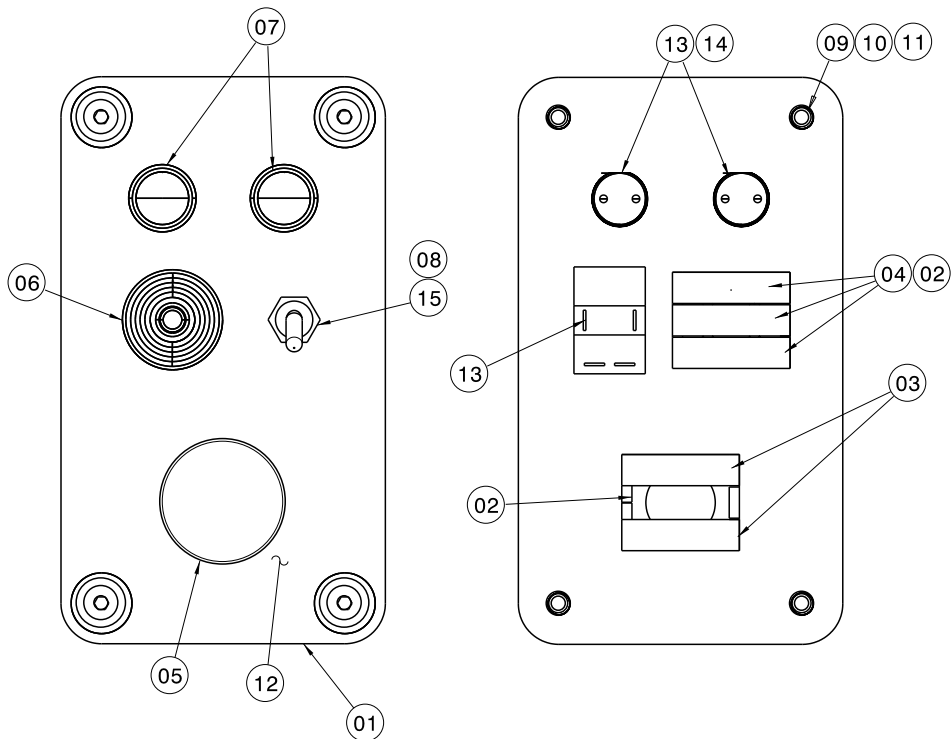
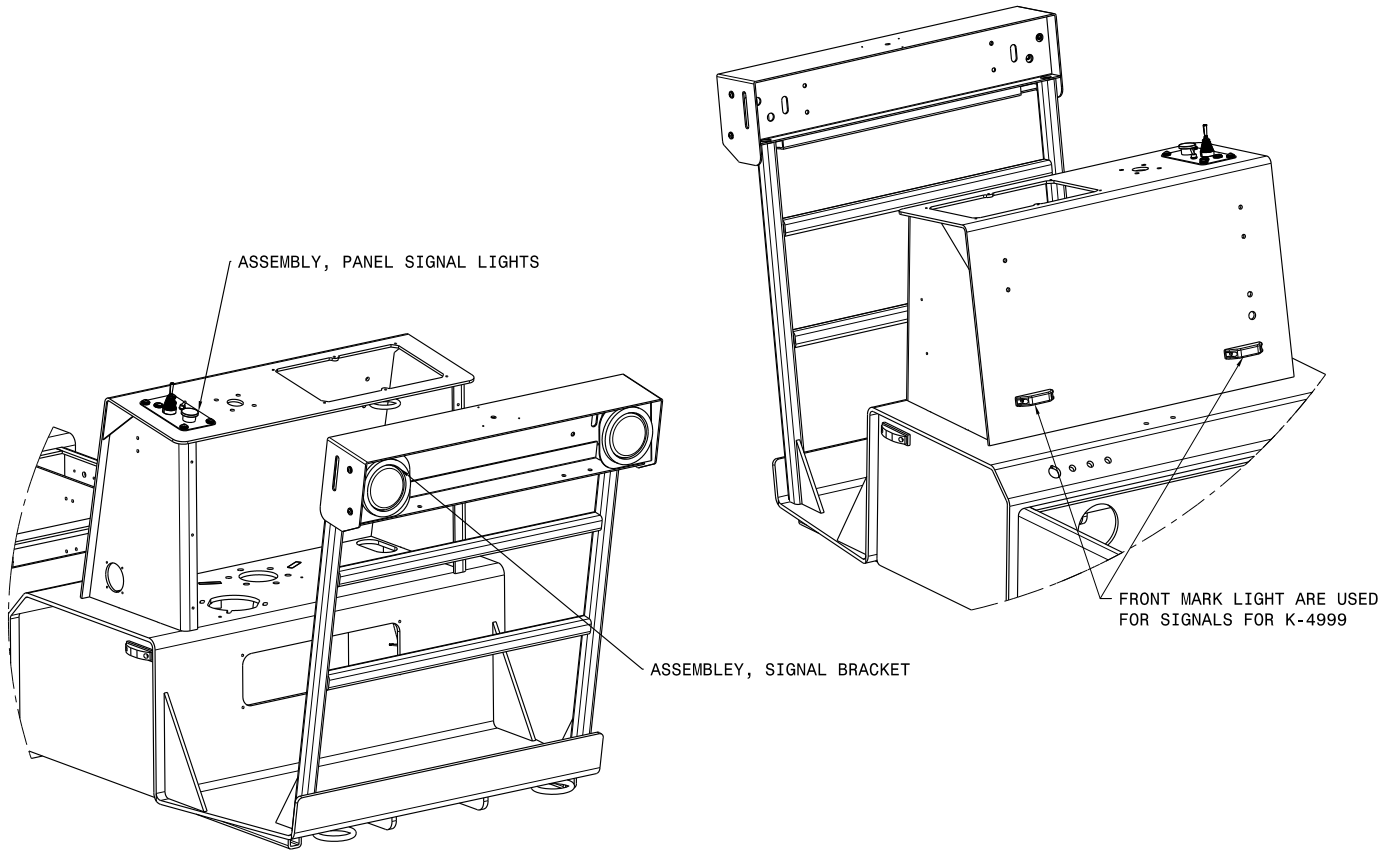

Parts List

When ordering replacement parts/kits, please specify model, serial number and color of your unit.

Item	Part Number	Description	Qty
1	S-2733-01	Panel, Switch	1
2	14142	Flange, Latch	2
3	14144	Block, Contact Red	2
4	14143	Block, Contact Green	3
5	EC-2817	Switch, Push Button	1
6	EC-2449	Switch, Toggle	1
7	EC-2826	Indicator, Green LED	2
8	EC-2747	Switch, Toggle 2 Position (DPST)	1
9	G-1503-1050N	Flatwasher, ¼ Narrow	4
10	G-1658-13	Washer, Neoprene, ¼	4
11	G-1476-105010	Screw, Socket Button head Cap, ¼ - 20	4
12	V-2579	Label, Panel Switch	1
13	EC-1326-01	Disconnect, Female	8
14	EC-1327-01	Tab, Male	4
15	EC-2744	Rubber, Switch Boots	1

Parts List

When ordering replacement parts/kits, please specify model, serial number and color of your unit.

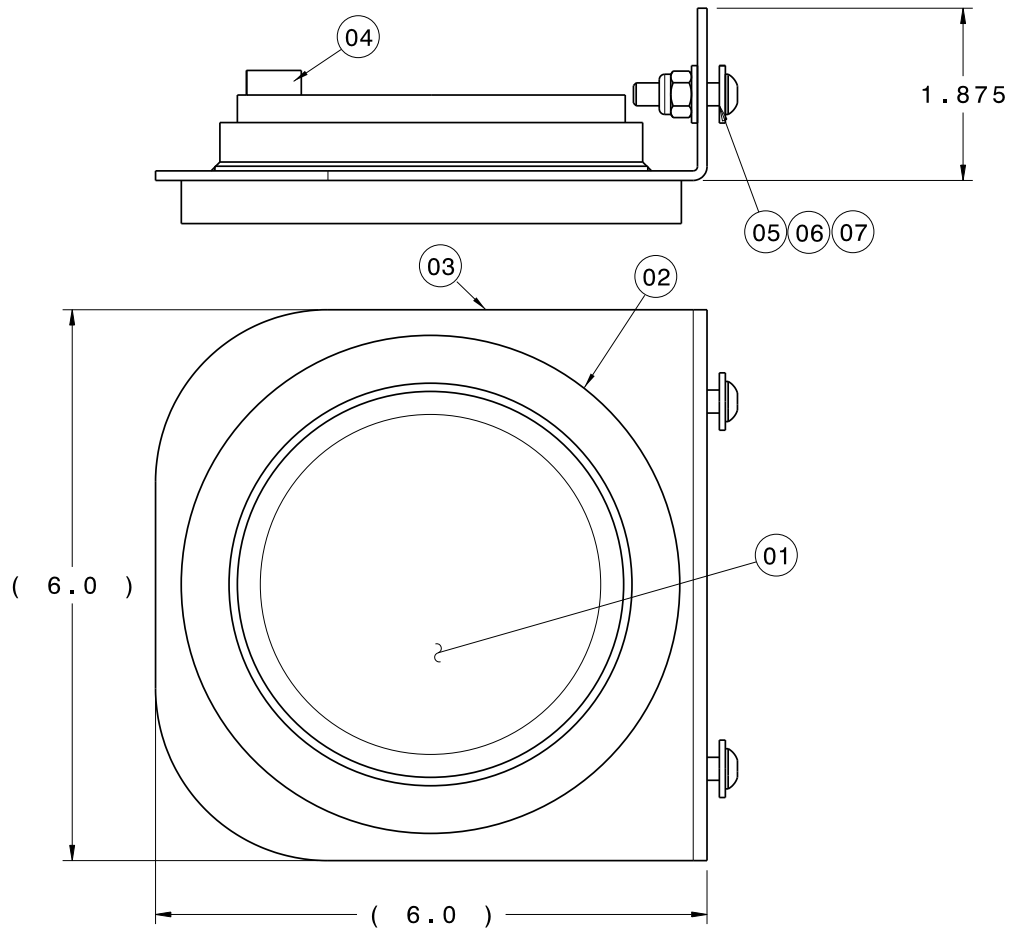

Item	Part Number	Description	Qty
1	EC-2819	Light, LED Red	1
2	H-3804	Bracket, Gasket	1
3	H-3805	Bracket, LED Holder	1
4	EC-2820	Harness, LED Light	1
5	G-1476-105010	Screw, Socket Button head Cap, ¼ - 20	2
6	G-1503-1050N	Flatwasher, ¼ Narrow	4
7	G-1202-1050	ESN, ¼ - 20	2



APPENDIX I

Hydraulic Schematic INS-1857

THIS DRAWING IS THE PROPERTY OF TRONAIR, INC. IT IS FURNISHED TO YOU FOR CONFIDENTIAL INFORMATION PURPOSES ONLY AND IS NOT TO BE DISCLOSED TO ANYONE ELSE OR REPRODUCED OR USED FOR MANUFACTURING PURPOSES WITHOUT THE EXPRESS WRITTEN PERMISSION OF TRONAIR, INC.

LET	REVISION	EC	DWN	CHK	DATE
-	ORIGINAL RELEASE	15190	-	-	08-08-06

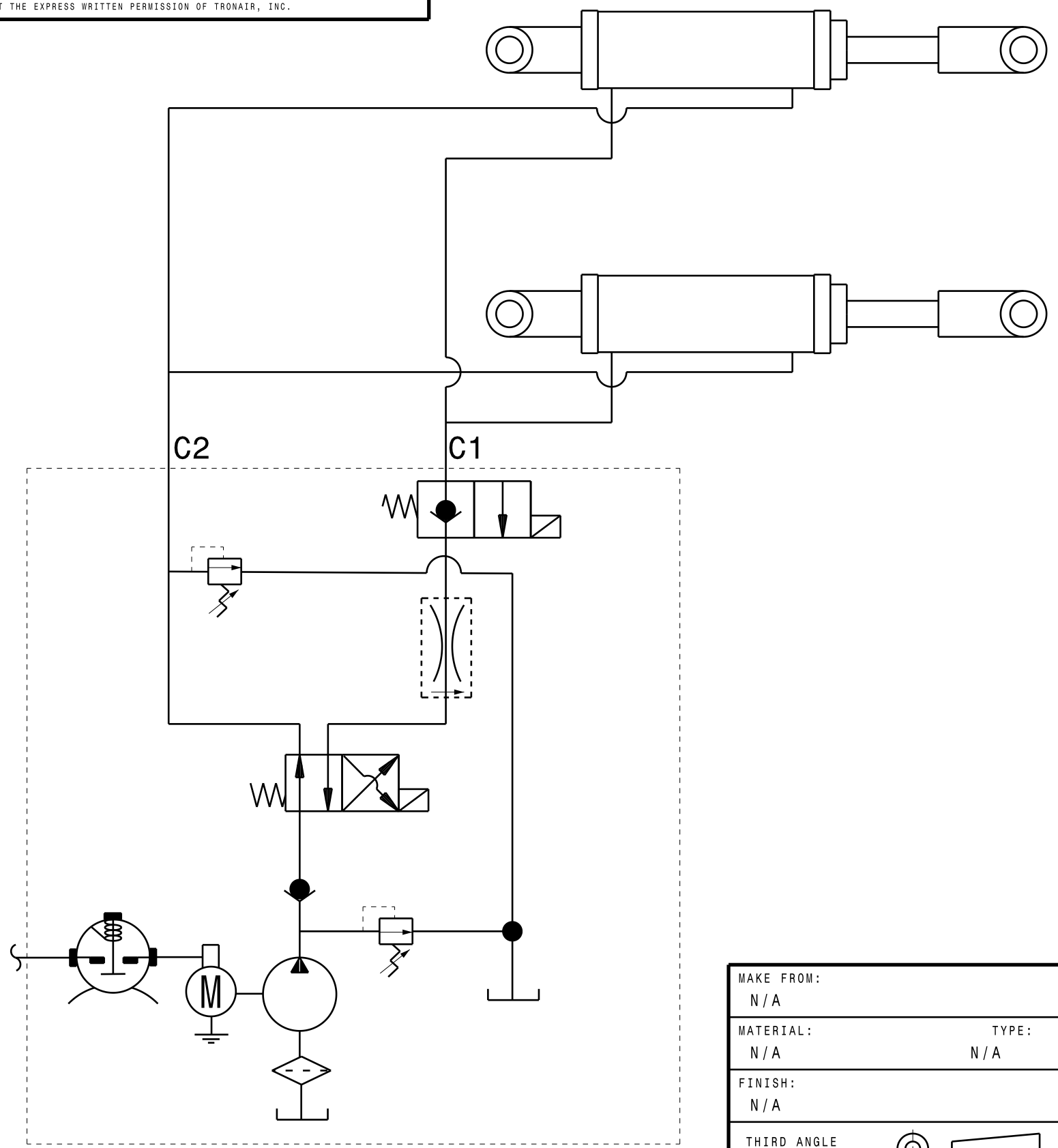

MAKE FROM: N/A	TYPE: N/A	
MATERIAL: N/A	FINISH: N/A	
THIRD ANGLE PROJECTION		SIZE B
SCALE: N.T.S.	DO NOT SCALE DRAWING	

BREAK ALL SHARP EDGES AND CORNERS
TOLERANCES UNLESS OTHERWISE SPECIFIED

DECIMAL	.X	± .100
	.XX	± .030
	.XXX	± .010
FRACTION	X/XX	± 1/16

ANGLES: ± 1/2 DEGREE
< > INDICATES CRITICAL DIMENSIONS
() INDICATES REFERENCE DIMENSIONS

TRONAIR AIRCRAFT GROUND SUPPORT EQUIPMENT

DWN BY	KJY	CKD BY	PEH	08-08-06
SCHEMATIC, HYDRAULIC				
JP	INS - 1857			REV -



APPENDIX II

Electrical Schematic INS-2276

NOTE:
 1 ALL WIRE IS 18 GA. UNLESS OTHERWISE NOTED OR IS AN EXISTING PART OF A COMPONENT.
 2 WHEN WIRING WITHOUT TURN SIGNAL OPTION, CONNECT LEFT AND RIGHT FRONT TURN SIGNALS (L15 AND L16) TO TB6 FOR USE AS MARKER LIGHTS.

(XX) - DEVICE TERMINATION

WIRE COLORS

NEGATIVE - GREEN
 24 VOLT POS. - BLUE
 48 VOLT POS. - BLACK
 POS. NON-SWITCHED - YELLOW

COMPONENT ABBREVIATION

KS - KEY SWITCH
 FU - FUSE
 PB - PUSH BUTTON
 JS - JOYSTICK
 TS - TOGGLE SWITCH

NEGATIVE FROM E-STOP (SWITCHED) 1/O CABLE F23 (JP30L) 1/O CABLE E12 (JP30)

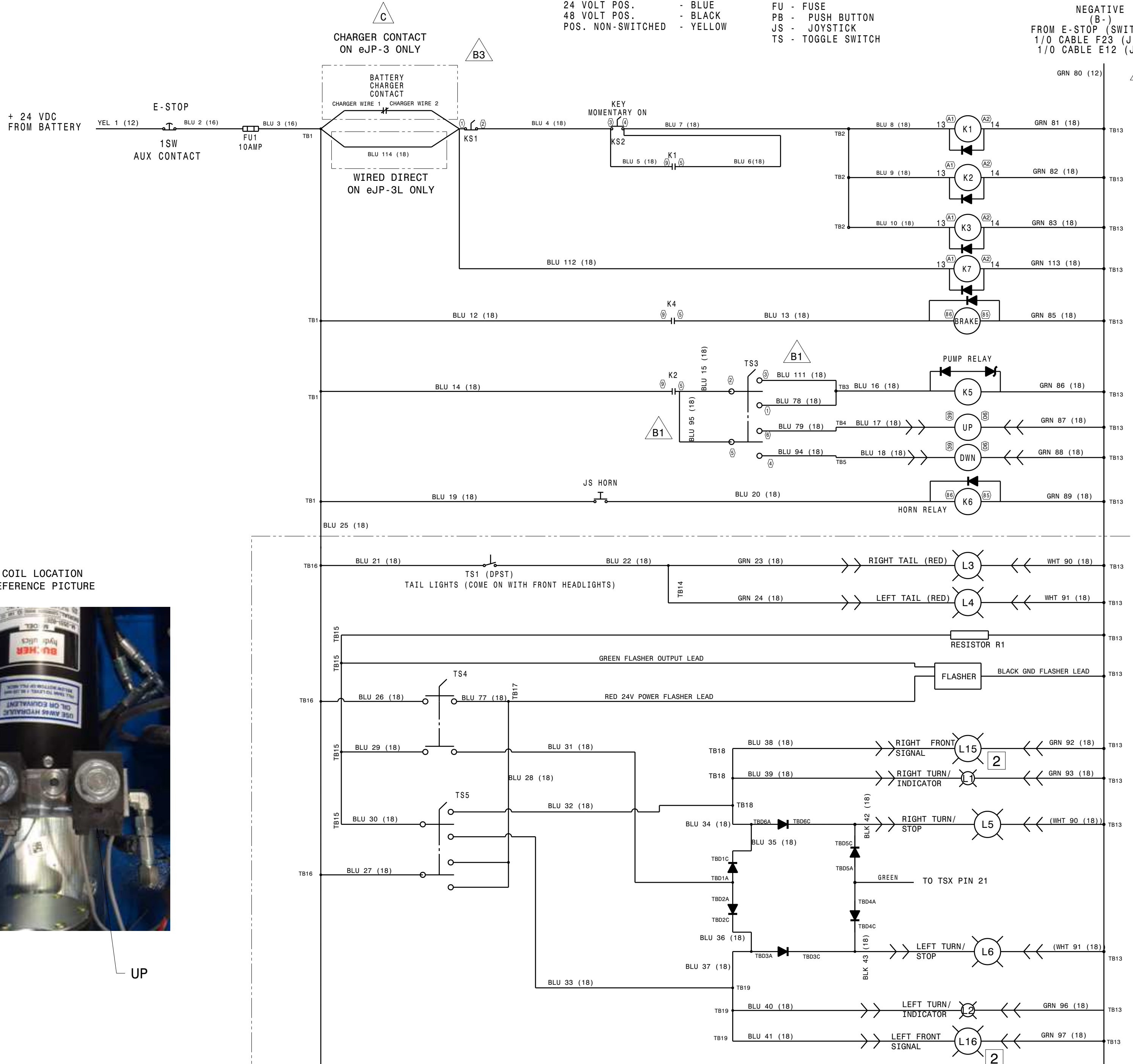

COIL LOCATION REFERENCE PICTURE



DWN UP

FOR UP/ DWN COIL LOCATION, SEE REFERENCE PICTURE.

TURN SIGNAL OPTION ONLY. SEE NOTE 2

FROM BATTERY + 48VDC 1/O BATTERY SIDE OF CONTACTOR 1/O CABLE F27 (JP30L) 1/O CABLE E16 (JP30)

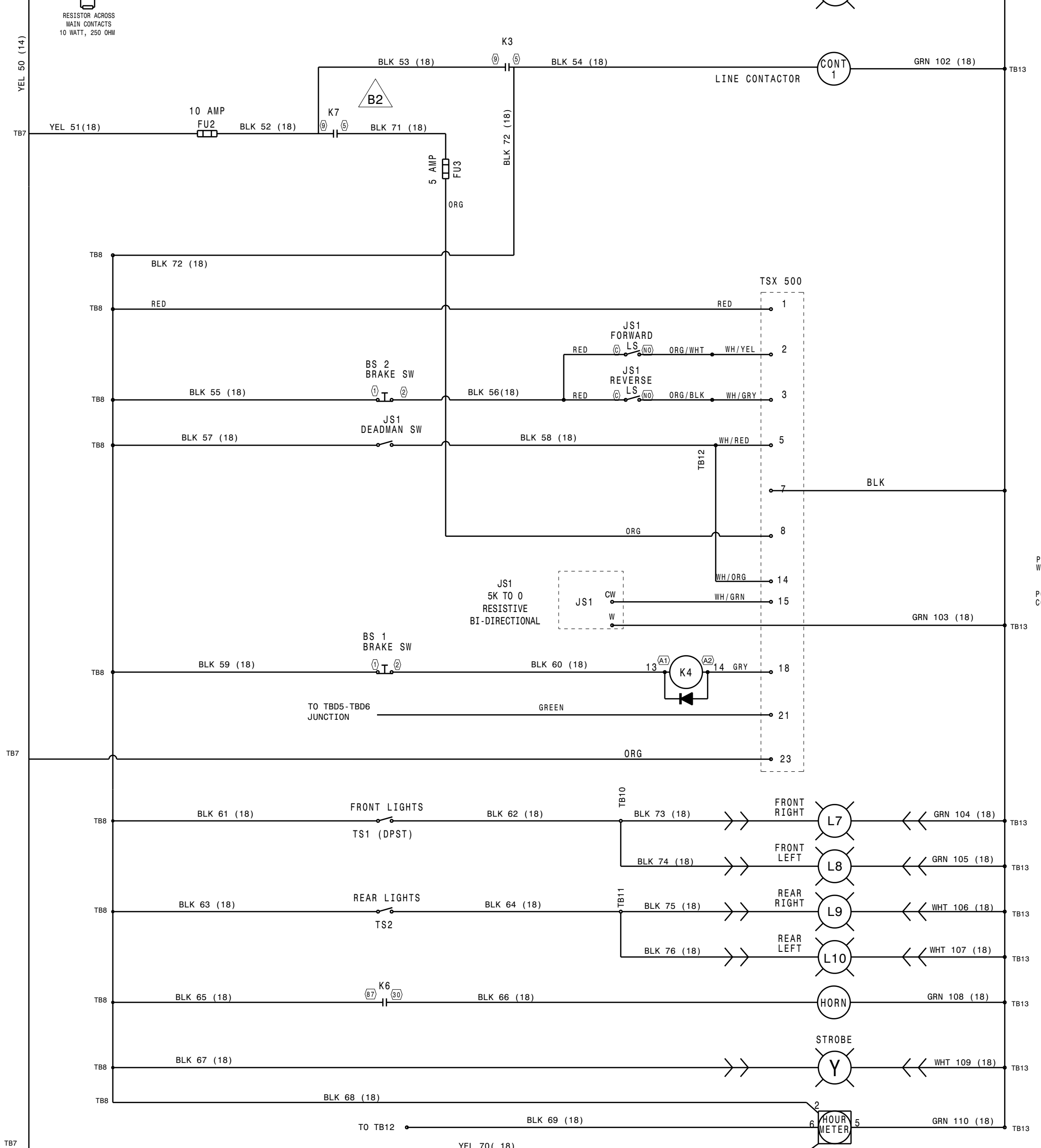

JOYSTICK TERMINAL BLOCK TO

FORWARD/ REVERSE COMMON	RED	BLK 56	BS 1 (2)
HORN	RED	BLU 20	K6 (86)
DEADMAN	RED	BLK 57	TBB
DEADMAN	VIOLET	BLK 58	TB12
HORN	YELLOW	BLK 19	TB1
BLANK			
FORWARD N.O.	ORG/ WHT	WH/ YEL	TSX 2
POTENTIOMETER REFER	GRAY	GRN 103	TB13
POTENTIOMETER COMMON	BLUE	WH/ GRN	TSX 15
REVERSE N.O.	ORG/ BLK	WH/ GRY	TSX 3

MAKE FROM: SEE B.O.M.
 MATERIAL: N/A
 TYPE: N/A
 FINISH: N/A
 HILL: N/A
 THIRD ANGLE PRODUCTION: N/A
 SCALE: N.T.S.

RESISTOR TOLERANCES UNLESS OTHERWISE SPECIFIED:
 TOLERANCES UNLESS OTHERWISE SPECIFIED:
 .XX(X) ± .100(10%)
 .XXX(X) ± .010(1.0%)
 .XXXX(X) ± .001(0.1%)
 FRACTION INCH (mm):
 1/XX (1/XX) ± .01(1%)
 1/XX (1/XX) ± .001(0.1%)
 1/XX (1/XX) ± .0001(0.01%)

TRONAIR
 KJY
 GAI
 01-20-15
 SCHEM, ELECTRICAL
 eJP-3(L)
 INS-2276

REV	DATE	CHK	DWN	EC	REVISION	LEFT
1	01-20-15	KJY	GAI	19755	B1 LISTS FIRST RUN NOTES FOR ADDING WIRE GAUGES BLU 112 AND GRN 113. BS CHANGED ORDER OF KS1 AND BATTERY CHARGER CONTACT.	
2	01-14-2020	GAI	21594		ADDED NOTE FOR CHARGER CONTACT WIRES	



APPENDIX III

**Wiring Diagrams
INS-2277 (eJP-3)
INS-2573 (eJP-3L)**

THIS DRAWING IS THE PROPERTY OF TRONAIR, INC. IT IS FURNISHED TO YOU FOR CONFIDENTIAL INFORMATION PURPOSES ONLY AND IS NOT TO BE DISCLOSED TO ANYONE ELSE OR REPRODUCED OR USED FOR MANUFACTURING PURPOSES WITHOUT THE EXPRESS WRITTEN PERMISSION OF TRONAIR, INC.

LET	REVISION	EC	DWN	CHK	DATE
A	ORIGINAL RELEASE	19589	-	-	01-16-15
B	MOVED CONTACTOR POS BATTERY DISCONNECT	19765	GAM	KJY	06-17-15
B	B1 WAS RED WIRE FROM CHARGER B2 ADDED WIRE YEL 1 SHOWN ON INS-2276 B3 WAS 125 VAC. ADDED NOTE 2.		EDITORIAL		06-14-16
B	ADDED NOTES FOR POS AND NEG CONNECTIONS		EDITORIAL		01-03-18

DRIVER'S POSITION REFERENCE

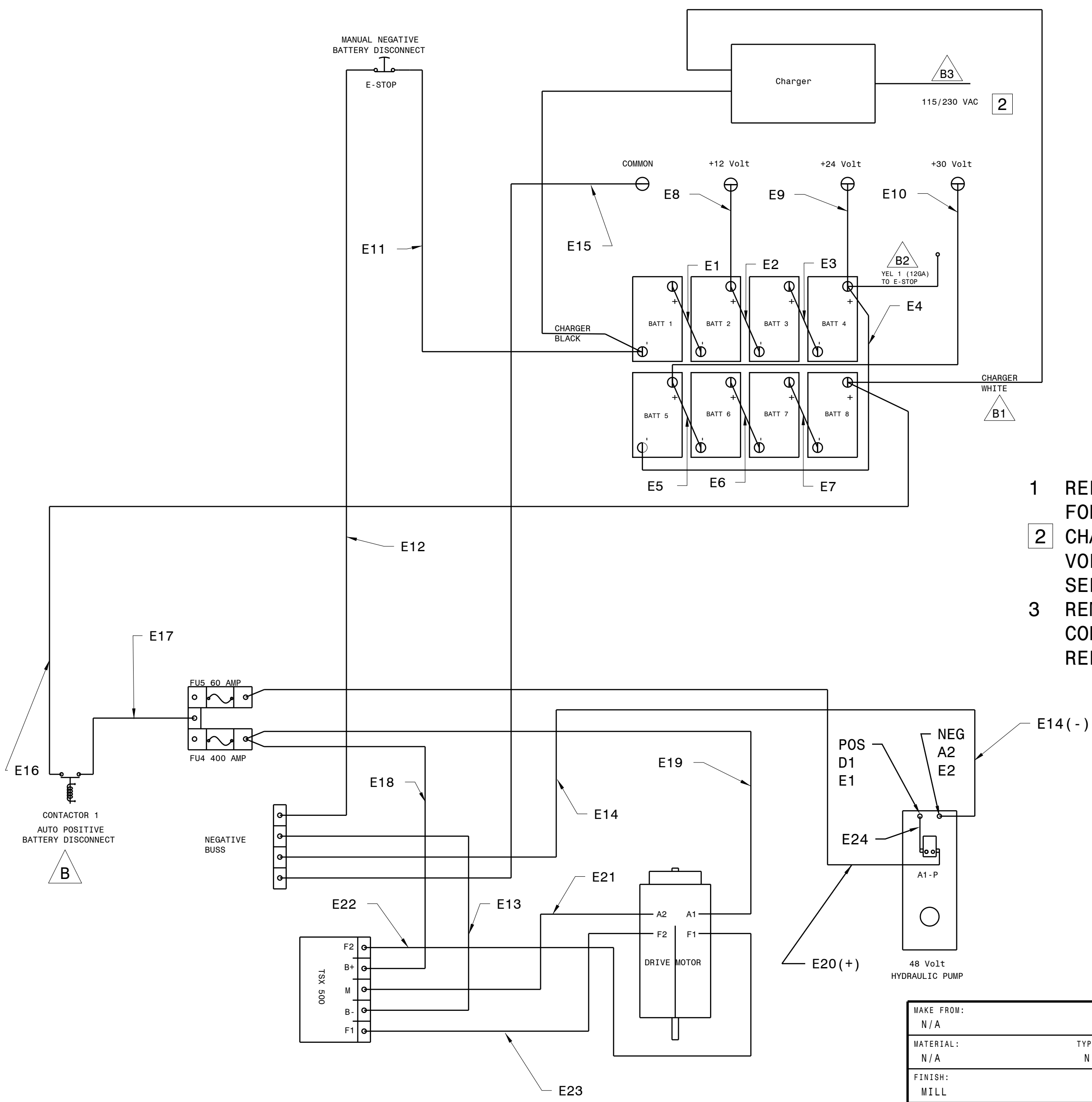

NOTES:

- REFERENCE EC-2835 DRAWING FOR CABLE MAKE-UP CHART.
- CHARGER IS INITIALLY SET UP FOR 115 VAC. VOLTAGE CAN BE CHANGED BY MOVING FUSE LOCATIONS. SEE OSM.
- REMOVE THE COPPER JUMPER STRAP AND THE PURPLE CONTROL WIRE FROM THE MOTOR RELAY. DISCARD BOTH. REPLACE THE COPPER JUMPER STRAP WITH CABLE E24.

MAKE FROM: N/A	TYPE: N/A
MATERIAL: N/A	FINISH: MILL
THIRD ANGLE PROJECTION	SCALE: N/A
DO NOT SCALE DRAWING	
SIZE C	

BREAK ALL SHARP EDGES AND CORNERS TOLERANCES UNLESS OTHERWISE SPECIFIED

DECIMAL	.X	± .100
	.XX	± .030
	.XXX	± .010
FRACTION	X/XX	± 1/16
ANGLES: ± 1/2 DEGREE		
< > INDICATES CRITICAL DIMENSIONS		
() INDICATES REFERENCE DIMENSIONS		

TRONAIR AIRCRAFT GROUND SUPPORT EQUIPMENT

DWN BY	GAM	CKD BY	KJY	DATE	01-19-15
DIAGRAM, PRIMARY WIRING					
JP	INS-2277			REV	B

THIS DRAWING IS THE PROPERTY OF TRONAIR, INC. IT IS FURNISHED TO YOU FOR CONFIDENTIAL INFORMATION PURPOSES ONLY AND IS NOT TO BE DISCLOSED TO ANYONE ELSE OR REPRODUCED OR USED FOR MANUFACTURING PURPOSES WITHOUT THE EXPRESS WRITTEN PERMISSION OF TRONAIR, INC.

DRIVER'S POSITION REFERENCE

LET	REVISION	EC	DWN	CHK	DATE
A	ORIGINAL RELEASE	21594	-	-	01/13/2020

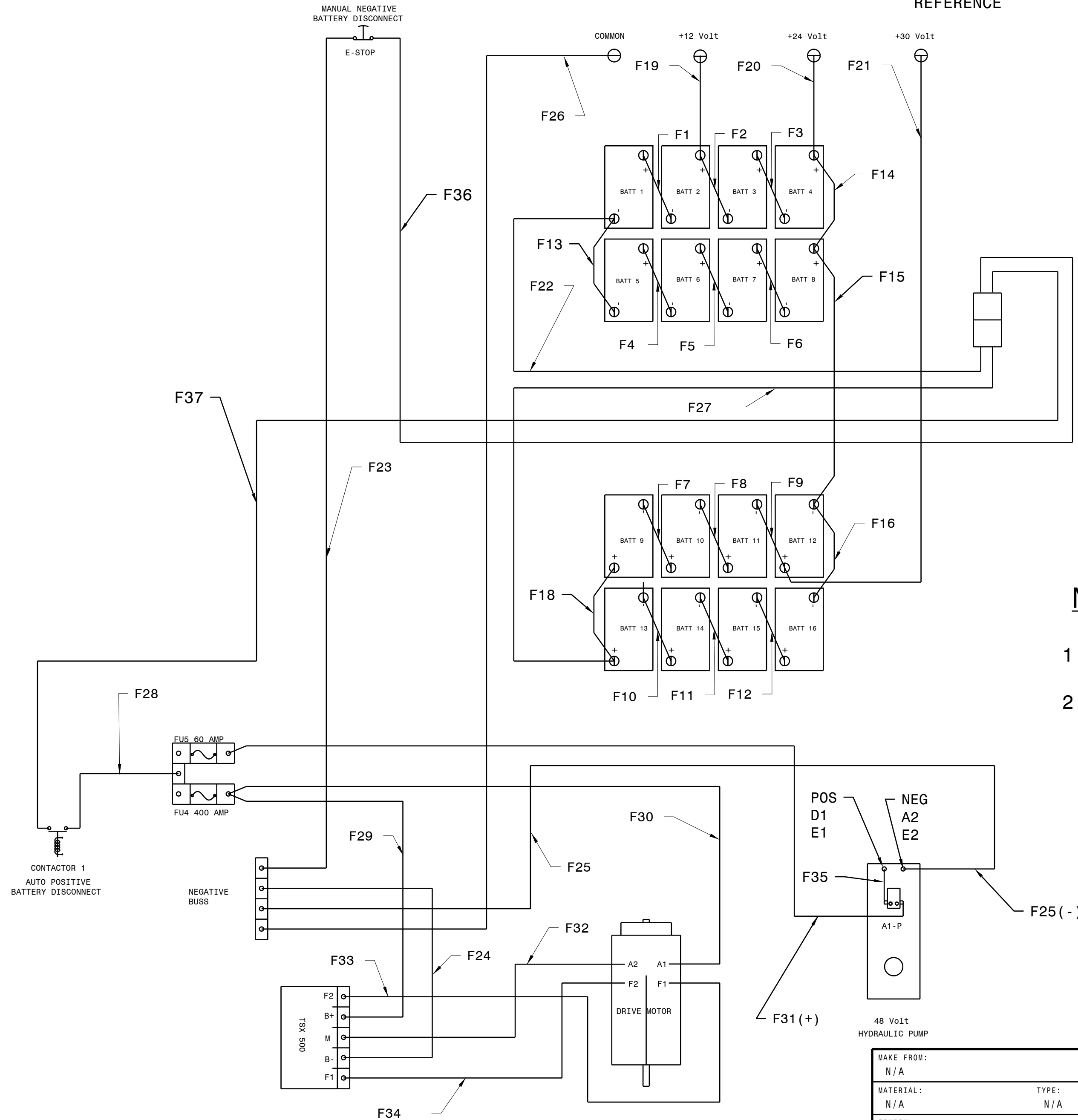

NOTES:

- 1 REFERENCE EC-2836 DRAWING FOR CABLE MAKE-UP CHART.
- 2 REMOVE THE COPPER JUMPER STRAP AND THE PURPLE CONTROL WIRE FROM THE MOTOR RELAY. DISCARD BOTH. REPLACE THE COPPER JUMPER STRAP WITH CABLE F35.

MAKE FROM: N/A	TYPE: N/A
MATERIAL: N/A	SIZE C
FINISH: MILL	THIRD ANGLE PROJECTION
SCALE: N/A	DO NOT SCALE DRAWING

BREAK ALL SHARP EDGES AND CORNERS TOLERANCES UNLESS OTHERWISE SPECIFIED

DECIMAL	.X	± .100
	.XX	± .030
	.XXX	± .010
FRACTION	X/XX	± 1/16
ANGLES: ± 1/2 DEGREE		
< > INDICATES CRITICAL DIMENSIONS		
() INDICATES REFERENCE DIMENSIONS		

TRONAIR AIRCRAFT GROUND SUPPORT EQUIPMENT

DWN BY	GAM	CKD BY	XXX	01-13-2020
DIAGRAM, eJP-3L PRIMARY WIRING				
JP	INS-2573			REV A



APPENDIX IV

Deep Cycle Battery Handling, Maintenance and Test Procedures

Safety. First.

Deep Cycle Battery Handling, Maintenance & Test Procedures

Crown Deep Cycle Batteries

The chemistry and plate design of deep cycle batteries are totally different than that of automotive starting batteries. The grid metal used in the deep cycle battery plate is specifically formulated to increase the adhesion of high-density active paste material. This provides the best available running time, cycle life and charge acceptance.

Crown Battery's heavy-duty plate design also protects against the stress of challenging Electric Vehicle (EV), motive power and RE (RE) applications – which includes vibration, heat and overcharge.

Crown deep cycle batteries employ a low-maintenance design. They do require periodic maintenance and effective charging service to ensure dependable service life. The purpose of this service guide is to help you understand the characteristics, operation and care of the batteries in your equipment so that all of their advantages may be fully realized.

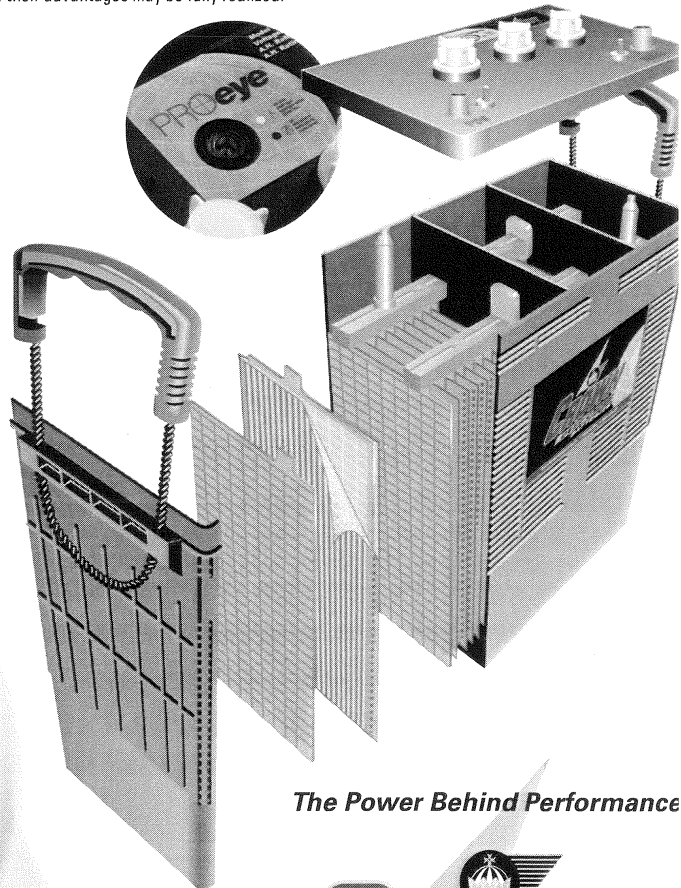

The Power Behind Performance

CROWN
DEEP CYCLE
BATTERIES

Inspection & Handling



1. Do not allow batteries in your equipment to tip or operate at a severe angle in any direction. This would allow the battery electrolyte to push through the battery vent assembly.
2. Charge the batteries in your equipment in a well-ventilated area.
3. Upon receipt of your equipment, examine the batteries for signs of wetness or impact (which may indicate damage in shipment or that the batteries were tipped beyond a 45° angle during transit).
4. If there is evidence of damage – notify Crown Battery or the OEM supplier to make a damage report.
5. Charge the batteries before placing the batteries in service. Simply connect the battery charger to your machine's charging port and allow it to run until it automatically shuts off.

Operating Guidelines

Deep cycle batteries supply all the power used in EV, motive power or RE system applications.

One full cycle represents a full battery recharge followed by a complete battery discharge (as specified by the OEM). Battery life is usually measured in cycles – but in practical terms, your batteries should work well for three years from the beginning date of service.

However, battery maintenance and charging procedures will either prolong or shorten battery life, depending upon how well recommended practices are followed.

Other Factors That Affect Battery Life and Performance:

- Batteries are rated in ampere-hours (Ah) and are designed to perform a specific workload within an established period of time. Increasing either and/or both of these will over-discharge the batteries and result in shortened life.
- Limit discharging the batteries beyond 1.75 volts per cell – or 1.125 specific gravity per cell. 1.75 volts per cell corresponds to end-point voltages of 5.25 volts for 6-volt batteries, 7 volts for 8-volt batteries and 10.5 volts for 2-volt batteries.
- Batteries should always be recharged immediately following a complete discharge period. Never allow batteries to remain in a fully discharged condition, otherwise permanent damage will result.
- If daily or routine equipment operation results in only partial discharges (40% or less) and specific gravities are 1.225 or higher, recharging may be deferred to the next day, providing the workload is not expected to increase.

Generally, user experience will determine the frequency of charging service under these circumstances.

- Under normal circumstance the temperature of the battery electrolyte must not exceed 110° F (43° C). If the battery is continuously operated at or above this point the service life of the battery will be severely diminished. Under normal conditions, battery electrolyte condition should range from 60° to 100° F (15° to 38° C). After charging, the battery should be allowed to cool-down or rest from 6 to 8 hours before the next discharge cycle begins.
- If a battery is ever hot to the touch, allow it to cool to ambient temperature before charging or discharging.
- Keep battery connectors and cabling in good condition. When disconnecting the battery connector from the equipment, pull on the connector – not the cable. Damage to the connectors and/or cables will result in poor battery performance.

Renewable Energy Charging Systems

To maximize performance and life batteries should be recharged fully after each discharge period. To verify full recharging, regularly monitor individual battery voltage and specific gravity. As a general rule, the total input amperes from your RE charging source should be between 10% and 20% of the total ampere-hours (20 Hour Rating) of the battery system capacity. Many RE charge controllers have adjustable equalization settings that ensure batteries are regularly restored to full capacity. Batteries used in RE systems should be equalized every thirty days at a minimum – with more frequent equalization occurring for battery systems

routinely discharged below 50% of their rated capacity. Please refer to the following chart for additional charge control setting information:

Voltage Setting	System Voltage				
	6 V	12 V	24 V	36 V	48 V
Daily Charge (Absorption)	7.5	15	30	45	59.5
Equalize	7.8	15.6	31.2	46.8	62.4
Float	6.8	13.5	27	40.5	54

Contact Crown Battery's technical support department for additional charging application information.

Watering Service

Deep cycle batteries begin service consuming relatively low amounts of water. In electric vehicle, motive power or RE service, the real need to add water to batteries may vary from weekly service to monthly service depending upon the operating environment and other external factors. As batteries age they will use more water, and in warmer climates batteries will require more frequent service. Equipment owners and users must be vigilant in performing regular watering service to ensure premium performance and life.

There are two conditions when watering can be harmful to your batteries:

- Over-Watering
- Under-Watering

Over-Watering dilutes the sulfuric acid levels inside the battery – which results in poor battery performance. Under-Watering batteries leads to a service-related overcharge condition, which will shorten battery running times and life.

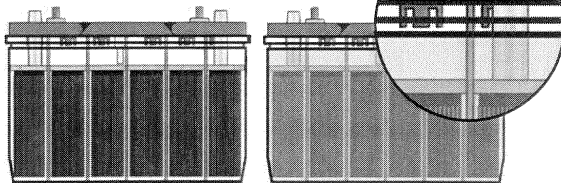

You can prevent watering-service related problems by using the illustration shown above as a reference point. Maintain battery liquid levels above the top of the battery plates – but no higher than the battery cover vent well. Never fill batteries to the brim of the cell or to a point where they overflow.

Several other rules apply when watering:

- USE ONLY DISTILLED or DE-MINERALIZED WATER.
- Never add battery acid, commercial additives or other foreign material to the batteries.
- Watering service should occur only after charging service is completed. Watering before charging service will result in overflow of the battery's electrolyte – causing a dangerous chemical spill

condition and loss of battery capacity.

- Never charge batteries if the battery plates are found to be uncovered/ un-submerged in electrolyte. If this condition is detected before charging service, fill the battery only until the top of the battery plates are covered with liquid.

Many Crown deep cycle batteries feature the PROeye indicator that shows users when watering service is required. When the color of the eye is:

- Green = No water service is required
- Clear or White = Watering service is required

The PROeye is an indicator only – and is designed to aid users with determining when individual cell inspection and/or watering service is required. Because watering service is most effective at the completion of charging service – the PROeye should be inspected at the completion of charge or before the start of duty cycle. Contact Crown Battery's technical department for more information regarding this product feature.

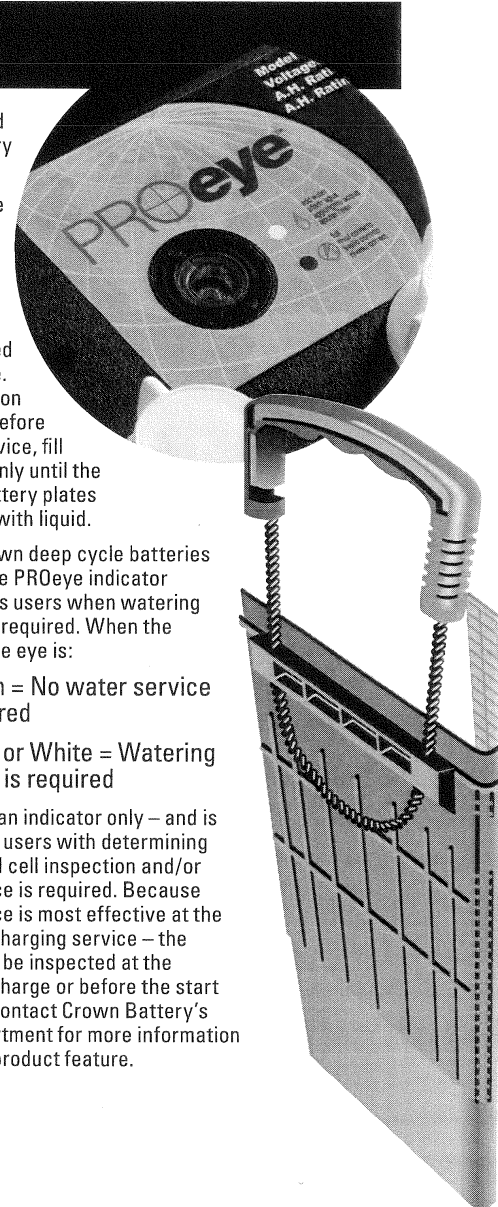

SAFETY PRECAUTIONS:

- 1. CAUTION:** All lead-acid batteries generate highly flammable hydrogen gas. If ignited, the gas may explode violently. When working near batteries, always wear safety glasses, do not smoke or use open flame near the batteries, remove watches and jewelry, and avoid causing sparks with tools.
- Battery electrolyte is corrosive and can cause blindness or severe burns. If exposed to battery electrolyte, immediately flush with water and seek medical attention.
- The batteries in your equipment are electrically live at all times. Keep the top of the batteries clean and dry to prevent ground shorts and corrosion.
- Do not tip a battery beyond a 45° angle in any direction. This would allow battery electrolyte to push through the battery vent assembly.

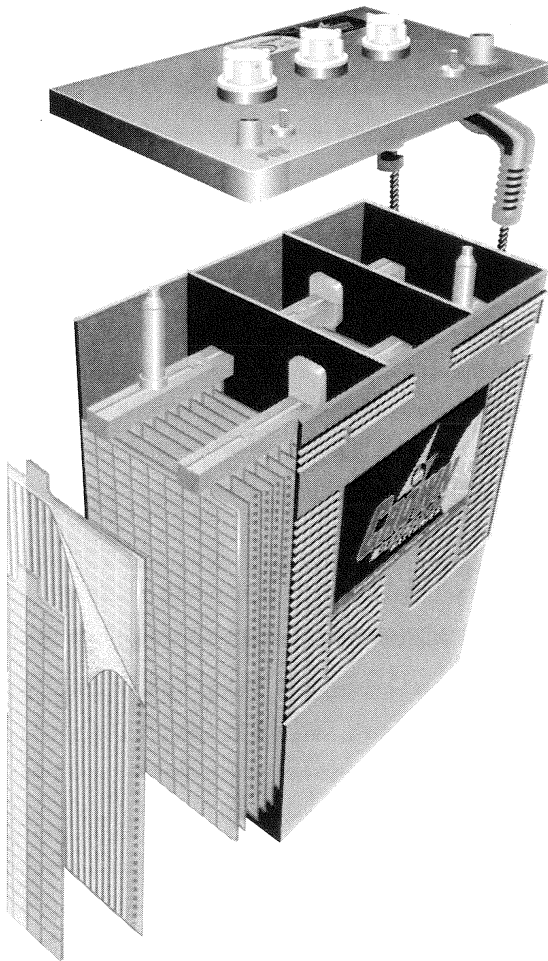

Preventative Maintenance

- Battery covers and terminals should be kept clean, dry and free of corrosion. Battery vent caps must be secured to the batteries during use and charging period. Remove vent caps only to inspect electrolyte levels or specific gravities.
- When batteries or terminals require cleaning, use only biodegradable cleaner-neutralizer solutions that can be safely applied and disposed of through a common sanitary sewer. Other chemical-based solutions are often dangerous, ineffective and cannot be disposed of in an environmentally safe manner.
- If electrolyte is spilled onto batteries or the battery compartment area, neutralize it with a cloth moistened with a solution of baking soda and water mixed in the proportion of one pound of baking soda to one gallon of water. When the electrolyte is neutralized, wipe the affected area with a water-moistened cloth to remove all traces of soda.
- Inspect cable-to-terminal connections to ensure connections are tight and free of corrosion. Battery cables must be intact with no exposed wires.
- Preventative maintenance practices should include periodic inspection of battery specific gravity and open circuit voltage. An imbalance of specific gravity and open circuit voltage is usually a sign of improper charging, service infrequency, or a bad cell condition.

The Power Behind Performance

CROWN[®]
DEEP CYCLE
BATTERIES

Charging Guidelines

EV or Motive Power Service

Original equipment systems usually include an automatic charging system for battery charging. To maximize battery life and performance, batteries should be charged as outlined in the operating instructions included with the charging equipment. In the event of a charging-related battery performance problem, consult the OEM or Crown Battery service department to seek technical support. Extra care spent in proper charging will ensure battery performance.

Battery charging equipment varies in terms of output and overall charging performance. For new or replacement chargers used in EV or motive power service, Crown Battery recommends electronically controlled automatic chargers that are programmed to deliver a high constant current rate of 12 to 18 amperes per 100 ampere-hours (20 Hour Rating) of battery capacity. The constant voltage phase begins after the gassing point is achieved (2.42 volts per cell). This stage of charge will last approximately 5 hours for a fully discharged

battery. During the constant voltage phase the charger voltage is limited to the gassing level (2.42 volts per cell), and the input current is allowed to gradually diminish. When the input current falls to the finish rate setting of 3 to 4 amperes per 100 ampere-hours (20 Hour Rating) of battery capacity, the charge phase will change from constant voltage to constant current at 3 to 4 amperes per 100 ampere-hours (20 Hour Rating) of battery capacity – with a maximum charging voltage of 2.65 volts per cell. The charge will be terminated approximately 3.5 hours from the gassing point by an approved charge termination method such as DV/DT. Please note that fixed ferro-resonant chargers using this profile must have finish voltages set at 2.58 volts per cell or higher.

Batteries should always be recharged immediately following a complete discharge period. A weekly equalization charge – with the finish rate charge time extended 3 hours for a total of 6 hours from the gassing point – will ensure reliable discharge time and battery life. The charge factor of the standard recharge cycle should be equal to or greater than 1.08 (108%), while the charge factor of the equalization cycle should be equal to or greater than 1.15 (115%). To ensure optimum battery performance, total recharge time should in all cases be limited to 10 hours.

Power off the charger before connection to the battery to avoid sparking. To avoid battery explosion, never charge a frozen battery – warming the battery to room temperature before charging service begins. Charging service should be terminated if batteries become excessively hot or if violent gassing or discharge of electrolyte occurs during charge.

Troubleshooting

When properly maintained and charged, Crown deep cycle batteries will provide many years of trouble-free service. However, failure to follow the operating and maintenance guidelines listed above may result in poor performance or premature failure. The following addresses some of the typical errors in operation and maintenance:

Condition	Check For
Poor Battery Performance	• Undercharged Battery
	• Sulfated Battery
	• Cold Operating Environment (Less than 32°F / 0°C Temperature Reduces Useable Battery Capacity)
	• Defective Connectors or Cables
	• Low Electrolyte
Unequal/Low Specific Gravities	• Old Batteries
	• Defective Charge-Level Gauge
	• Over-filling
Excessive Water Service	• Undercharging
	• Overcharging
	• Container Leak
Odor During Charging	• Old Batteries
	• Low Electrolyte
High Temperature	• Overcharging
	• Overcharging
	• Battery Overworked
	• Opportunity Charging

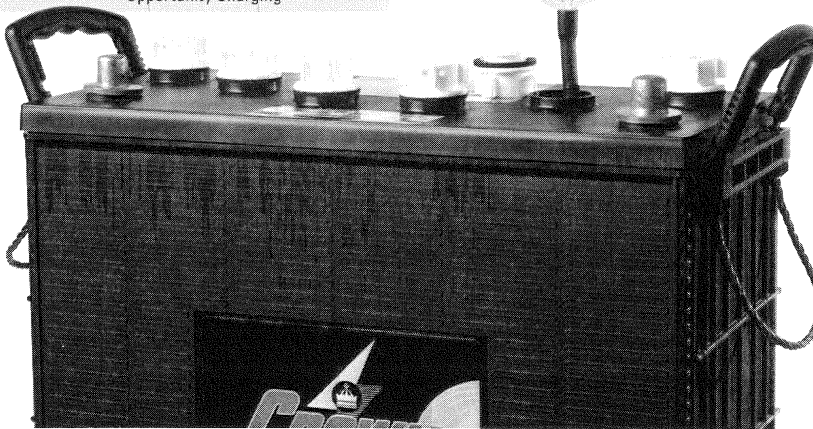
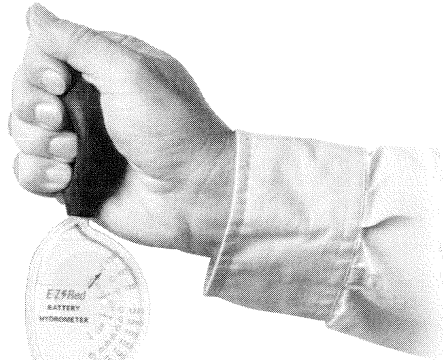

Troubleshooting

A common procedure for troubleshooting battery performance involves a three-point procedure:

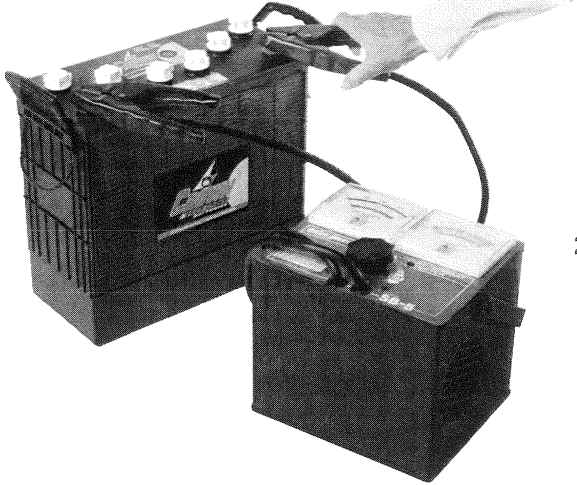

1. Visual Inspection: Check battery age or length of service if available. Inspect battery for damage - when physical damage to the battery container or terminals is present, replace the battery. If none, check the battery's cell electrolyte levels. Fluid levels should be above the top of plates in all cells, and no higher than the top of the fluid level indicator:

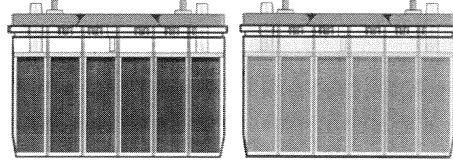

If the battery is sufficiently filled with electrolyte - proceed to step

2. If the top of the battery's plates are not covered with liquid, add water, replace vent caps and place the battery on charge. Be sure no open flame or spark is near while the battery's vent caps are removed from the battery.

2. Specific Gravity Inspection: Hydrometer reading of all cells should be at least 1.235 and show less than 50 points difference between high and low. More than 50 points difference: replace the battery. Less than 50 points, but some cells read less than 1.235: recharge the battery. Replace the vent caps during recharge. Charge the battery using a properly matched automatic charger until all cells measure a specific gravity of 1.275 to 1.280. If charging won't bring up specific gravity, replace the battery.

Example:	Hydrometer Float	State of Charge Level	Specific Gravity
CELL 6 - 1.200	CELL 6 - 1.225	100%	1.280 or Greater
CELL 5 - 1.210	CELL 5 - 1.230	75%	1.235 - 1.240
CELL 2 - 1.215	CELL 2 - 1.235	50%	1.190 - 1.195
CELL 1 - 1.240	CELL 1 - 1.240	25%	1.150 - 1.175
CELL 3 - 1.240	CELL 3 - 1.245	Discharged	1.125 or Less
CELL 4 - 1.255	CELL 4 - 1.250		

VARIATION 55 POINTS BATTERY WORN OUT
 VARIATION 25 POINTS READY TO LOAD TEST

3. Open Circuit Voltage and Electrical Load Test: Battery open circuit voltage is an effective indication of battery state of charge. Determine the approximate state of charge from the following chart.

Electrical load testing is an effective troubleshooting technique for identifying batteries with internal defects - but it is not an approved method for measuring deep cycle battery capacity. For this reason Crown Battery recognizes load test results as useful only for identifying batteries having bad cell conditions.

Batteries with less than 75% state of charge should be charged before an electrical load test is applied to the battery. When load testing batteries, remove all battery cables, disconnecting the negative cables first. Make sure the battery terminals are free of corrosion and dirt.

For batteries having stainless threaded stud terminals, attach a lead charging post to the threaded stud terminal before testing. Using a carbon pile load tester, apply a 50 to 75 ampere load for 15 seconds; remove the load. Refer to the chart at the left to determine the minimum passing voltage.

State of Charge Level	12 Volt Battery Open Circuit Voltage	6 Volt Battery Open Circuit Voltage
100%	12.6 or Greater	6.3 or Greater
75% - 100%	12.4 - 12.6	6.2 - 6.3
50% - 75%	12.2 - 12.4	6.1 - 6.2
25% - 50%	12.0 - 12.2	6.0 - 6.1
0 - 25%	11.7 - 12.0	5.95 - 6.0
0%	11.7 or Less	5.95 or Less

Chart Assumes a Fully Charged Gravity of 1.280.

State of Charge	Battery Voltage Under 15 Second Load		
	12 Volt	6 Volt	Specific Gravity
100%	12.66	6.33	1.280
75%	12.00	6.00	1.235

If the test voltage is above the minimum, return the battery to service. If test voltage is below the minimum, replace the battery.

The Power Behind Performance



Crown Battery Manufacturing Co.
Made in the USA

1445 Majestic Drive • P.O. Box 990
Fremont, OH 43420-0990

419-334-7181 • Fax 419-334-7124

www.crownbattery.com

sales@crownbattery.com

Battery Care...Maintenance

Battery Inventory Management

Batteries should be stored in a cool, dry area in an upright position. Store batteries on a solid surface that can safely accommodate their weight. Batteries can be safely stacked two or three layers high by using a secure stacking surface (wafer-board, plywood, etc.) placed between each layer. When stacking batteries in layers, take care to secure battery terminals against short-circuit and to block-and-brace batteries to prevent any movement of the battery group.

Use or sell oldest battery inventory first (*First In, First Out*). Batteries require periodic stock rotation and service charging to ensure peak performance. Batteries marked with Shipping Date Codes older than 6 months from the current date should be service charged before sale or use. Shipping Date Codes follow a universal code standard. For example, L5 = Battery shipped in December 2005:

Month	Year		
A – January	G – July	1 – 2001	6 – 2006
B – February	H – August	2 – 2002	7 – 2007
C – March	I – September	3 – 2003	8 – 2008
D – April	J – October	4 – 2004	9 – 2009
E – May	K – November	5 – 2005	0 – 2010
F – June	L – December		

Recommended Charging Practices

- Before charging service, refer to the charger manufacturer's instructions for correct charger-to-battery connection and equipment operation.
- Power off the charger before connection to the battery to avoid sparking.
- For batteries fitted with threaded stud terminals or GM-type side terminals, use only lead charging posts that ensure a flush lead-to-lead terminal surface contact. Verify that charging posts are securely tightened to the terminal, which will enable safe and effective charging service.
- To avoid battery explosion, never charge a frozen battery. Frozen batteries should be warmed to room temperature before charging service begins.
- Check battery cell electrolyte levels to ensure that liquid levels are above the top of the plates in all cells. If plates are not covered, add only enough water to cover plates, replace vent caps and place on charge. Be sure no open flame or spark is near while the battery's vent caps are exposed. After charging, fill with water and replace vent caps on the battery.
- Charging service should be terminated if batteries become excessively hot or if violent gassing or discharge of electrolyte occurs during charge.
- Avoid "quick" or "fast" charging batteries in all cases. Limit charger input current to 25% of the battery's reserve capacity minutes rating. Lower current input charges the battery more uniformly and creates less heat, which reduces the possibility of overcharge. Remember, overcharging ruins batteries.
- Monitor battery state-of-charge throughout the charging period, continuing the charge until a three-hour period shows no additional voltage or tapering of charge current. Refer to page 1 for full-charge voltage and specific gravity points.

Recommended Jump-Starting Practices

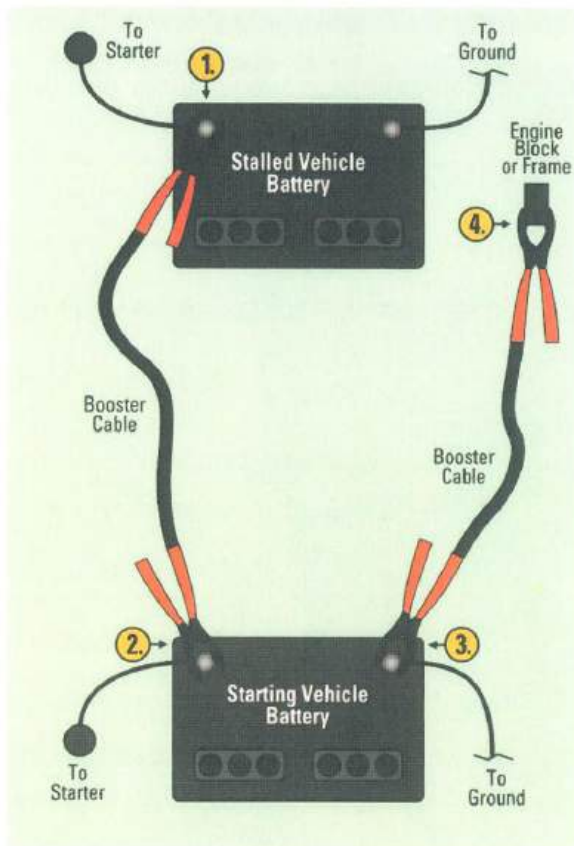

Refer to the vehicle owner's manual for manufacturer's recommended procedure.

Make it a point to wear personal protective equipment whenever jump-starting batteries – shield your eyes and face at all times, wear heavy-duty protective gloves before touching batteries or jumper cables.

Make certain that battery vent caps are tight and level. Place a heavy cloth over both batteries' vent caps. Keep a safe distance between vehicles involved in jump-starting, making sure vehicles don't come into contact while jump-starting occurs.

1. Connect one end of the booster cable to the positive terminal of the discharged battery.
2. Connect the other end of the positive booster cable to the positive terminal of the assisting battery.
3. Connect one end of the negative booster cable to the negative terminal of the assisting battery.
4. Complete the jump-start connection by securing the other end of the negative booster cable to the engine block of the vehicle having the discharged battery – as far away from the discharged battery as possible. Be aware of safety risks while completing this connection, such as moving fan blades, belts and fuel lines.



APPENDIX V

eJP-3 Battery Charger Operating Instructions



APPENDIX VI

eJP-3L

Battery Charger Operator/Installer Manual



WARNING

Consult local, state or national electric codes for battery charger installation in an aircraft hangar.

DC POWER TECHNOLOGIES

TOMORROW'S TECHNOLOGY FOR TODAY'S APPLICATION

OPERATOR / INSTALLER MANUAL

MODULAR CHARGER

FS3



XHP **eco**
SERIES **CHARGE**



WARNINGS



Keep open flames away from batteries on charge.



Risk of battery explosion.



Be aware of battery fumes and electrolyte.

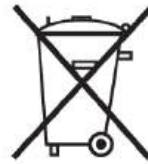

Do not dispose of batteries in the garbage.

Pb



Electrical hazard exists inside the charger, do not remove the side cover.



Always recycle lead acid batteries.

Pb



Battery electrolyte is highly corrosive.



Wear eye protection when working near batteries.

2. Warnings

Contents

Warnings	2
Contents	3
Location	4
Mounting Bracket Options	5
Installation	6
FS3 Block Diagram	9
Operating Instructions	10
Front Panel (Set Equalize Charge)	12
Charger Configuration Settings	14
Charger Alarms	15
Battery Alarms	17
Troubleshooting	20
Exploded View	22
Spare Parts	23
Maintenance	25
Service & Warranty	26
Specifications	27

Charger Serial Number	
Charger Part Number	
Date Supplied	
Vehicle Model	
Purchaser	
Purchase Invoice Number	
Fleet Number	

Location

The preferred installation is where the charger(s) can be located on a shelf, protected against accidental contact with the lift truck or its forks.

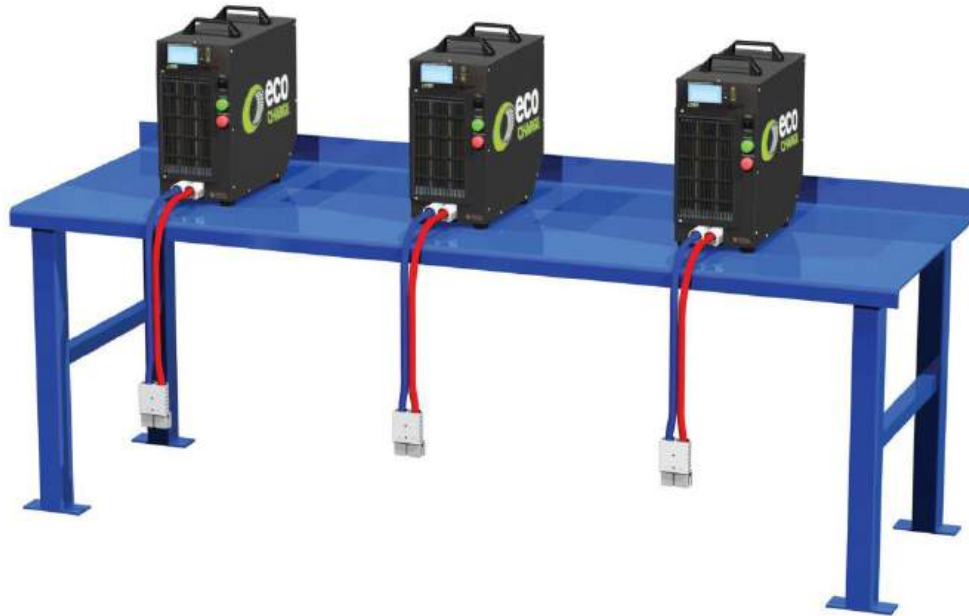

With the charger on a shelf the risk of damage to the charger or battery cables is greatly reduced.



Avoid just placing the charger on the floor next to the lift truck.

4. Location

Mounting Bracket Options



Base Mount

1. Fix the mounting bracket to a bench using a type of fastener that suits the bench material.
2. Remove the 2x front case feet.
3. Slide the base of the FS3 onto the mounting bracket.
4. With 2x M5x8 hex bolts (included with the mounting bracket) secure the front of the mounting bracket to the FS3.
5. When fitting the battery cable ensure the locking screw is installed.



Side Mount

1. Fix the mounting bracket to the wall using a type of fastener that suits the wall material.
2. Slide the side of the FS3 onto the mounting bracket.
3. With 2x M5x8 hex bolts (included with the mounting bracket) secure the front of the mounting bracket to the FS3.
4. When fitting the battery cable ensure the locking screw is installed.









Rear Mount

1. Fix the mounting bracket to the wall using a type of fastener that suits the wall material.
2. Slide the rear of the FS3 onto the mounting bracket.
3. With 2x M5x8 hex bolts (included with the mounting bracket) secure the front of the mounting bracket to the FS3.
4. When fitting the battery cable ensure the locking screw is installed.

Installation

AC Input & Busbar Connection

Charger Model Number	Charger Modules	Supply Phase	DC Output	Supply Voltage	AC Supply in Max. Amps. Per Phase	Aux. Plug	Busbar Selection	Config. Number
FS3LUE-512	2x MP130	Single Phase	24/36/48V	208-240	28-30*	J5		1/2
FS3LUE-522	2x MP130	Three Phase	24/36/48V	208-240	15.5-23.2**	J5		3
FS3LUE-513	3x MP130	Single Phase	24/36/48V	208-240	28-30*	J5		1/2
FS3LUE-523	3x MP130	Three Phase	24/36/48V	208-240	13.3-27**	J5		3
FS3LUE-532	2x MP330	Three Phase	24/36/48V	380-480	8-10	J6		4
FS3LUE-533	3x MP330	Three Phase	24/36/48V	380-480	12-15	J6		4

* in single phase mode the output power will reduce to maintain maximum AC current draw.

** in three phase mode the adding of the third charger module reduces the AC current draw to achieve the same DC output as for two modules.

Charger Model Number

FS3LUE-5xy

FS3 = Frame size.

MPx30 = 1 for MP130 or 3 for MP330.

y = 2 or 3 modules installed.

6. Installation

AC Filter Board Configuration - Step 1 of 3

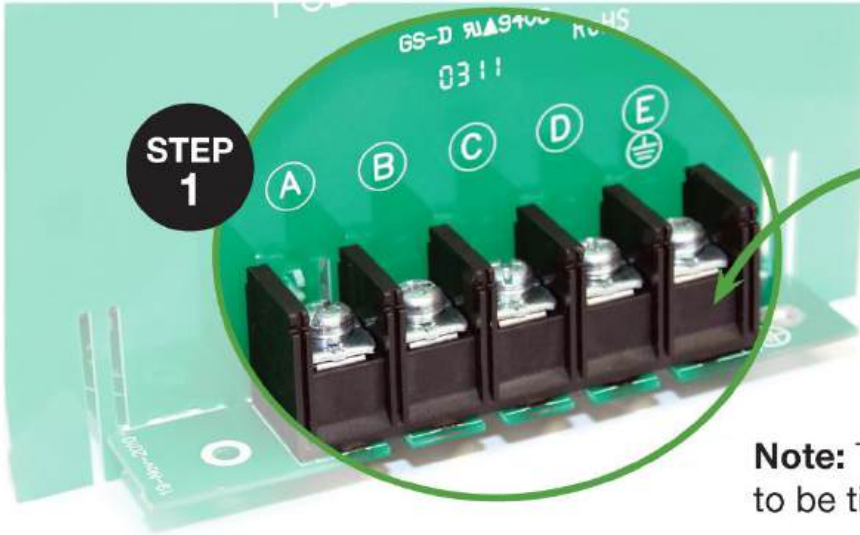

AC Input Terminal Block

Note: Terminal connections to be tightened to 21 in.lbs

Configuration 1 - MP130
208-240V AC Single Phase.

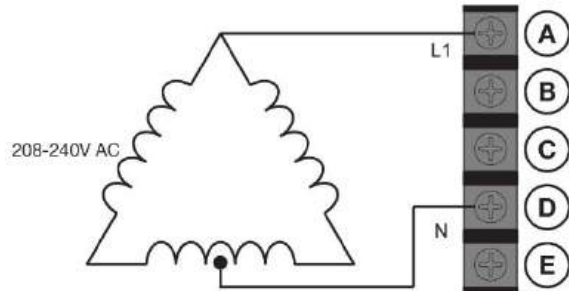

Configuration 2 - MP130
208-240V AC Single Phase Split Leg.

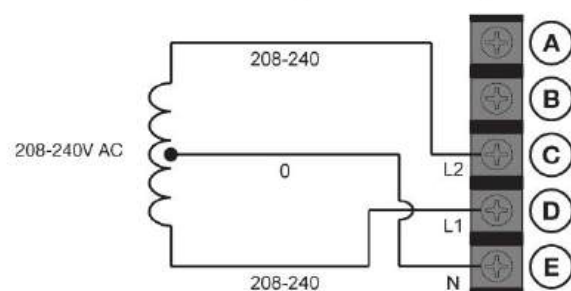

Configuration 3 - MP130
208-240V AC Three Phase.

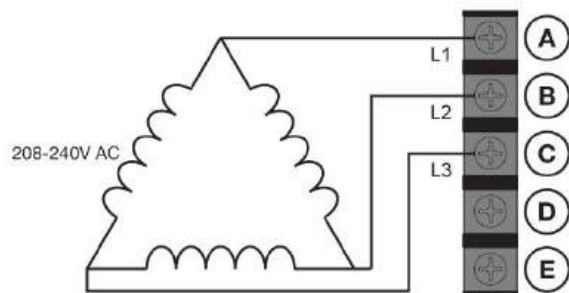

Configuration 4 - MP330
480V AC Three Phase.

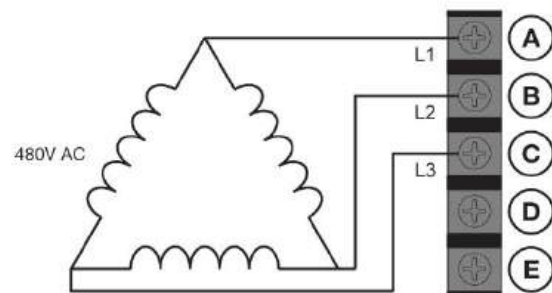

Note: It is common in the US that a fourth wire (neutral) be used in a triple phase circuit. If present, it should be attached to the "E" terminal.

Installation

AC Filter Board Configuration - Step 2 of 3

208-240V single phase configuration.

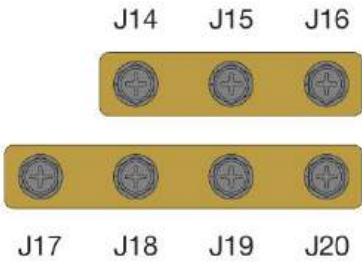

208-240V three phase configuration.

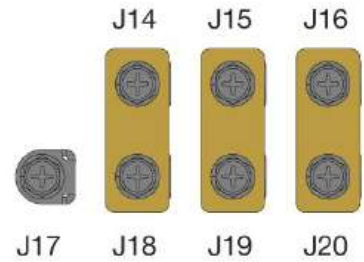

480V three phase configuration.

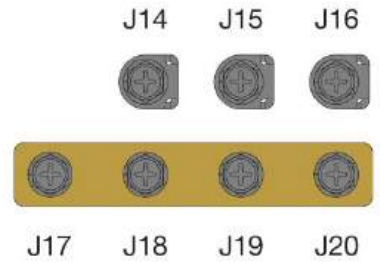

Use an 8mm socket on the M5 hex head bolts to secure the busbars in place. Unused busbar connections are bolted to the internal rear of the FS3 cabinet.

AC Filter Board Configuration - Step 3 of 3

AUX power supply connection to 208-240V outlet J5.

AUX power supply connection to 480V outlet J6.

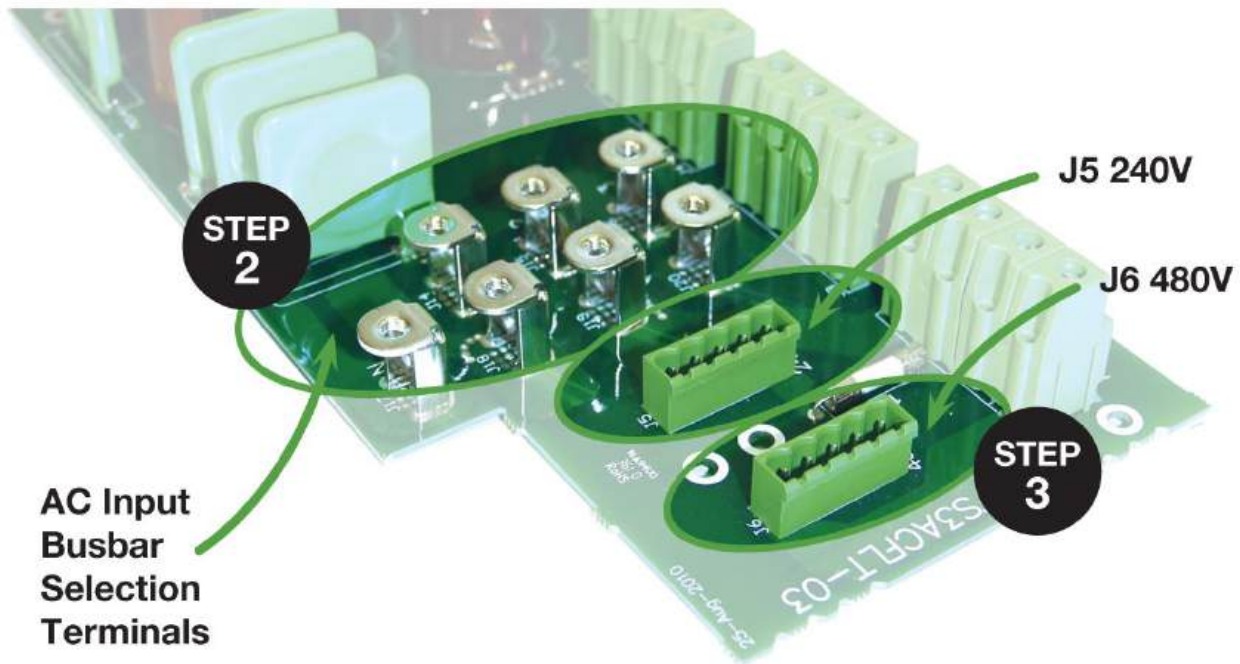

FS3 Block Diagram

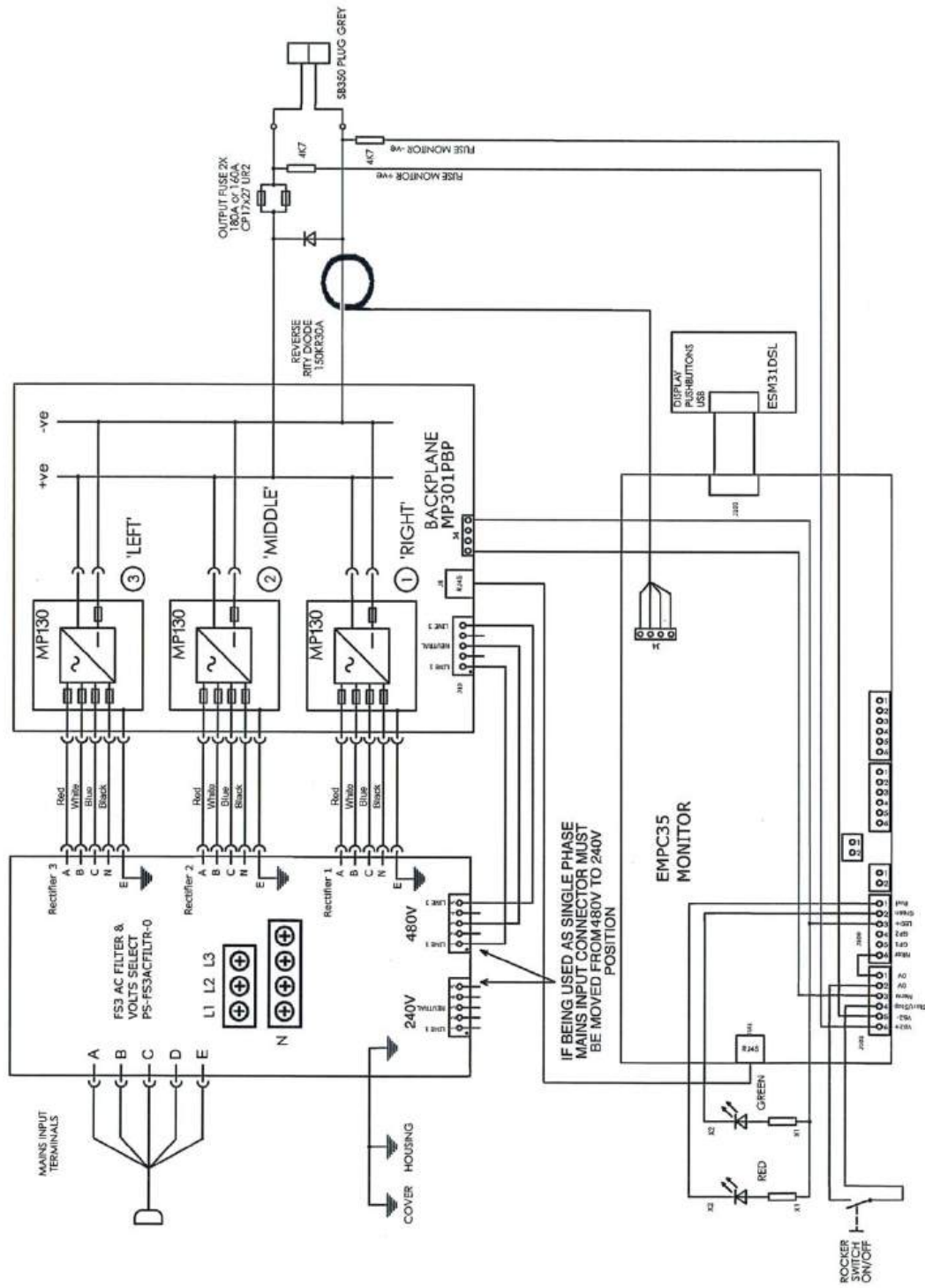

Operating Instructions

- 1 Check the battery leads are in good condition before proceeding.
- 2 Set the rocker switch to **STOP**.
- 3 Plug the charger in and turn on the AC supply.
- 4 Check the voltage, amperage and battery type indicated on the charger's display matches the battery to be charged.
- 5 Connect the battery to the charger using the correct cable.
- 6 Set the rocker switch to **START**.
- 7 The red **CHARGING** light will illuminate to indicate charging has commenced.
- 8 When the green **READY** light illuminates, charging is complete.
- 9 Set the rocker switch to **STOP** and then disconnect the battery from the charger.

10. Operating Instructions

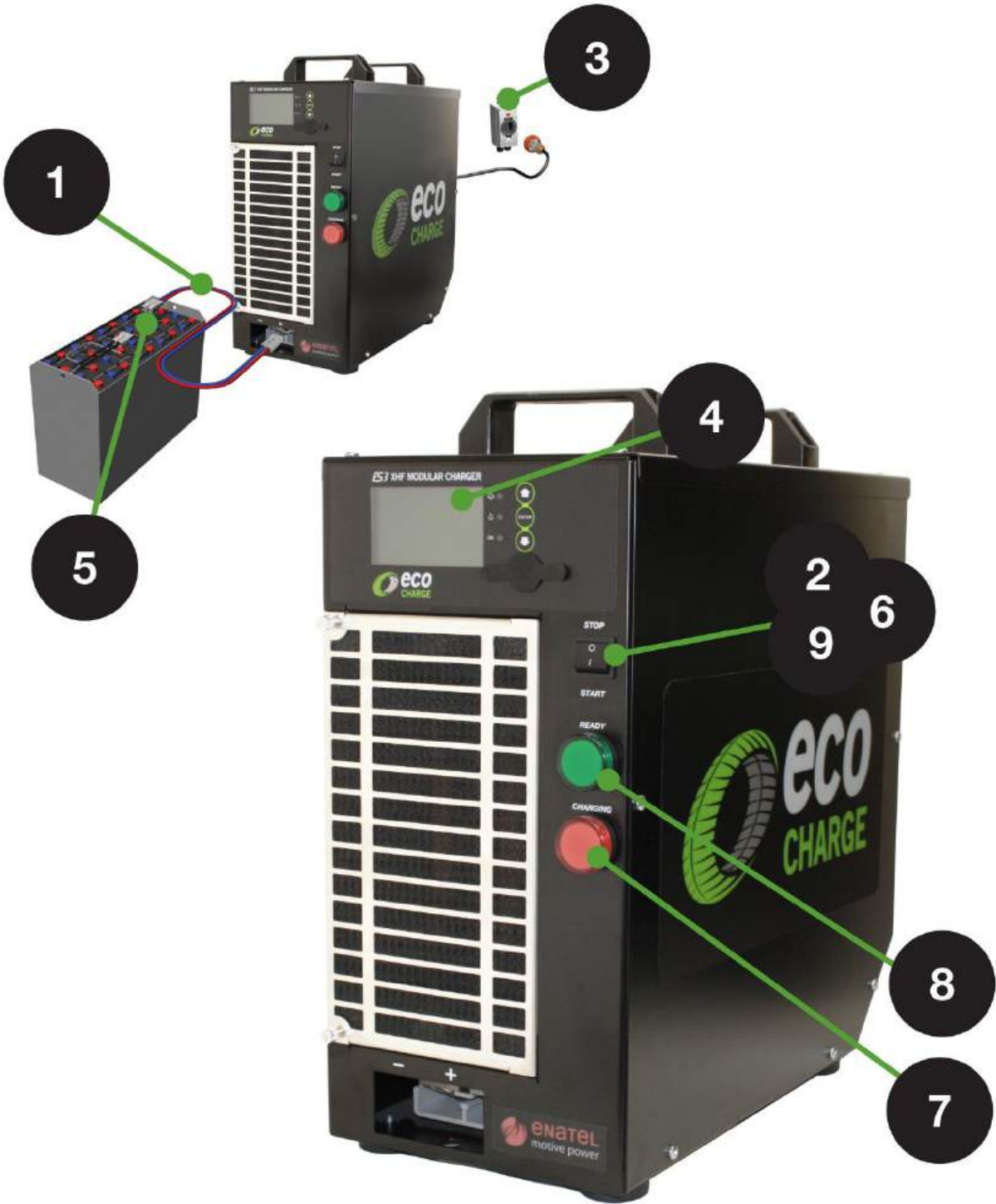

Front Panel

1





Controller display.

Displays information depending on the status of the charger.

2

Controller push buttons (Set Equalize Charge).

To enable equalize next cycle, plug in the battery but before setting the rocker switch to **START**:

- Press  button to set equalize next cycle.
- Press ENTER to allow changing.
- Press  to select "Enable".
- Press ENTER to accept change.
- Press  to select "Store".
- Press ENTER to accept.
- Press  to return to "Connect Battery".
- Set the rocker switch to **START**.

3

Mini USB port.

4

START/STOP rocker switch.

0 = Stop charge.

I = Start charge.

5

READY/CHARGING indicator lights.

RED steady on, GREEN off = Charging.

RED off, GREEN steady on = Charge complete.

RED flashing, GREEN off = Non-Urgent Alarm.

RED flashing, GREEN flashing = Urgent Alarm.



When a Non-Urgent Alarm is indicated the charge cycle has still completed and in most cases can be disregarded.

When an Urgent Alarm is indicated, the charge cycle has not been completed and the occurrence must be reported to a Supervisor, your servicing battery dealer or DC Power Technologies at 844-ECO-CHRG.

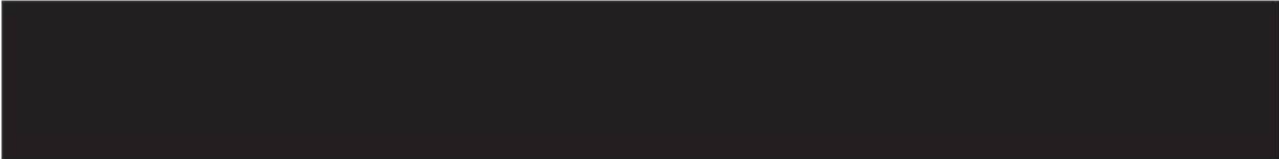

RED LED same as RED indicator.

AMBER LED same as GREEN indicator.

GREEN LED illuminates when charger is powered up.



UP button.

ENTER button.

DOWN button.

Display when no battery connected or rocker switch set to *STOP*.

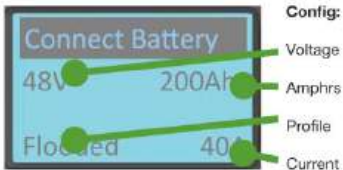

Display when charging.

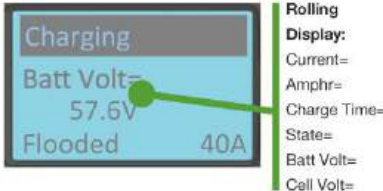

Display when charge complete.

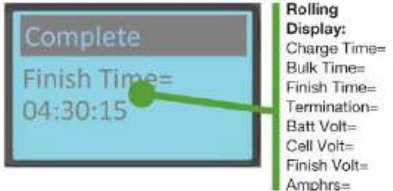

Charger Configuration Settings

Charge Profiles Available

Conventional IU1a/IE1.
Opportunity charge.

Amp Hr Ranges

Conventional profile:
24V (300-1200 amp hr).
36V (300-1200 amp hr).
48V (300-950 amp hr).

Opportunity profile:
24V (300-750 amp hr).
36V (300-750 amp hr).
48V (300-600 amp hr).

Battery Types

Flooded.
Sealed.
Gel.
AGM.

Environments

Standard.
Freeze/cold condition.

Cable Length

Adjustable to any length.

Equalize Charge Settings

Cycle count:
Adjustable to any number.
Default setting is to equalize charge after every 5 complete charge cycles.

Day/time:

Select day and time of the week to trigger an equalize charge on the next charge cycle. Can also select to have it equalize charge every other week.

Manual equalize:

Select to have an equalize charge run from the display panel.

Contact DC Power Technologies for assistance with the adjustment of these settings.

Phone : 1-844-ECO-CHRG

www.DCPowerTechnologies.com

Charger Alarms

Main Switch	Non-Urgent Module Fail	Configuration Error	APC Communications Fail
Inlet Filter	Urgent Module Fail	Output Fuse	APC Incorrect Voltage
Low Mains	Module Fan Fail	No Output Current	APC Unknown Charger
Mains Fail	Module Over Temperature	Monitor ADC Fail	

Charger Alarms

Main Switch. Urgent Alarm, shows the status of the front panel **START/STOP** rocker switch.

Inlet Filter. Non-Urgent Alarm, can give warning as to when the inlet filter needs servicing but is not enabled by default.

Low Mains. Non-Urgent Alarm, gives a indication of variation in the input mains voltage without actually affecting the ability of the charger to provide rated output. Can also indicate a charger module being overloaded.

Non-Urgent Module Fail. Non-Urgent Alarm, there is a charger module that is not providing output but the charger is still operating, but redundancy has been lost.

Urgent Alarms. When an urgent alarm is triggered, please note the charger will terminate its charge cycle prematurely.

Mains Fail. Urgent Alarm, a mains loss situation and the charge cannot proceed.

Urgent Module Fail. Urgent Alarm, if the number of charger modules not providing output equals or exceeds the setting for urgent module count in the monitor tab then the charger will stop. If urgent module count is set to one then the charger is configured without redundancy and a single fault will stop the charge.

Module Fan Fail. Non-Urgent Alarm, in the event of a complete fail of the cooling fans the effected module will back off the maximum output current available to level where natural convection of heat will allow the module to continue operating.

Charger Alarms

Module Over Temperature. Urgent Alarm, normally related to a blocked filter or restricted exhaust air or installation in an inappropriate location.

Configuration Error. Urgent Alarm, the charger cannot meet the target current required by the controller even with all fitted charger modules operating or the configuration does not meet the limits set for a 10A mains input hardware limited charger.

Output Fuse. Urgent Alarm, a blown fuse in nearly all cases is caused by connecting a reverse polarity battery to the charger. When a fuse is blown, check all batteries for reverse cable connection. A common problem is with first charge of shift batteries that have not been previously tested in a lift truck. After replacing a battery or charger cable always closely check the polarity before plugging the battery onto the charger.

No Output Current. Urgent Alarm, the charger is not providing the expected output current. Generally related to a premature disconnection of the battery, but also could be an incorrectly inserted charger module.

Monitor ADC Fail. Urgent Alarm, internal watchdog of the controllers micro-controller indicating a major fault and potential unpredictable behaviour if the charger is left running.

APC Communications Fail. Urgent Alarm, the APC module has failed to communicate with the charger.

APC Incorrect Voltage. Urgent Alarm, the charger cannot produce the voltage required by the battery.

APC Unknown Charger. Urgent Alarm, the charger cannot find the required profile.

16. Charger Alarms

Battery Alarms

Over Discharged Battery	Bulk Charge Timeout	Minimum dV/dt	+dI/dt
Deeply Discharged Battery	Finishing Charge Timeout	Maximum Cell Voltage	Minimum Current
Sulphated Battery	Battery Disconnected	Batt Over Temp - Start	EQ/Refresh Timeout
Incorrect Battery	Reversed Battery	Batt Over Temp - Charge	

Battery Alarms

Over Discharged Battery. Urgent Alarm, the battery is still under 1.9Vpc after 30 seconds of charge which indicates a faulty battery that needs investigation.

Deeply Discharge Battery. Non-Urgent Alarm, the battery at start is under 1.9Vpc but recovers within 30 secs of charge, normally comes up when the battery is quickly unplugged from the lift truck and plugged into the charger.

Sulphated Battery. Urgent Alarm, deactivated by default.

Incorrect Battery. Urgent Alarm, the battery voltage is inappropriate for the configuration of the charger and cannot be charged without reconfiguring the charger to suit the battery.

Bulk Charge Timeout. Urgent Alarm, the battery has exceeded the maximum time allowed for the initial constant current bulk charge phase. Could indicate a faulty battery or the charger configuration is not correct for the size of battery to be charged. May need additional charger modules added to the charger.

Battery Alarms

Finishing Charge Timeout. Non-Urgent Alarm, the battery has exceeded the maximum time allowed for the finishing part of the charge cycle. Generally not a major problem and indicates the battery did not quite perform as expected. Not uncommon with new batteries that are still cycling up to full capacity (allow 10 cycles) however if the alarm is a regular occurrence it needs investigation and possible adjustment of the charger or service of the battery.

Battery Disconnected. Urgent Alarm, the battery has been unplugged before charge cycle has complete. This can damage the battery connector and increase risks of battery explosions as sparks around batteries at their top of charge whilst gassing can be very dangerous. If the battery needs to be disconnected mid cycle, the toggle switch must be first set to STOP. This will stop the charge and log a partial cycle in the charge log but allows safe disconnection of the battery.

Reversed Battery. Urgent Alarm, a battery with it plus and minus cables reversed has been connected to the charger. Generally this will also cause an output fuse alarm and the need to replace the chargers DC output fuse(s). Such a situation is not covered by warranty as new batteries should always first be checked for correct polarity BEFORE plugging onto the lift truck or a charger.

Minimum dV/dt . Non-Urgent Alarm, details the change in battery voltage over time. The alarm occurs when the change in voltage exceeds the value set in profile settings. This alarm also indicates the termination of a successful charge.

18. Battery Alarms

Maximum Cell Voltage. Non-Urgent Alarm, occurs when the voltage per cell exceeds the value set in the profile settings. Typically 2.7V per cell for lead acid batteries.

Batt Over Temp - Start. Urgent Alarm, occurs when the battery temperature measured before a charge profile starts exceeds the value set in the controller settings. This alarm will not allow the charge profile to continue.

Batt Over Temp - Charge. Non-Urgent Alarm, occurs when the battery temperature measured during a charge profile exceeds the value set in the controller settings. This alarm will allow the charge profile to complete.

+di/dt. Urgent Alarm, occurs when the measured current in the constant voltage stage is rising instead of falling. This alarm will terminate the charge profile.

Minimum Current. Non-Urgent Alarm, occurs when using a IU profile and the current in the constant voltage stage falls below the value set in the profile settings. This alarm will not stop a profile and is considered normal for some types of batteries.

EQ/Refresh Timeout. Non-Urgent Alarm, occurs when the time in a given stage of the equalize profile has exceeded the value set for that stage of the profile. This alarm will terminate the equalize charge but is not considered an Urgent Alarm.

Troubleshooting

Problem	Possible Cause	Remedy
Main Switch Alarm.	Front panel switch in the STOP position.	Charge will start when the switch is set to START.
Inlet Filter Alarm.	Air inlet filter blocked.	Clean the filter.
Low Mains Alarm.	AC mains supply is low or charger modules may be overloaded.	Check configuration of the charger suits the application.
Non-Urgent Module Fail Alarm.	Charger module not providing output, there is capacity to charge at a reduced rate.	Replace the faulty charger module(s).
Urgent Module Fail Alarm.	Faulty charger modules are affecting the ability of the charger to charge the battery.	Replace the faulty charger module(s).
Module Fan Fail.	Faulty charger module fan.	Replace charger module.
Module Over Temperature.	Charger module is overheating.	Check air inlet filter is not blocked, check the charger is installed without any obstructions to air inlet and outlet.
Configuration Error.	Charger cannot provide the target output current.	Check the controller configuration matches the quantity of power modules installed, add charger modules if necessary.
Output Fuse.	Blown output fuse.	Check battery polarity. Replace blown fuse.
No Output Current.	Charger failing to provide the required current.	Check operator has not been unplugging battery mid charge cycle or the charge profile has allowed the battery current to fall below 0.7A.
Monitor ADC Fail.	Faulty MPC31 controller module.	Replace the MPC35 controller module ensuring the replacement is correctly configured.





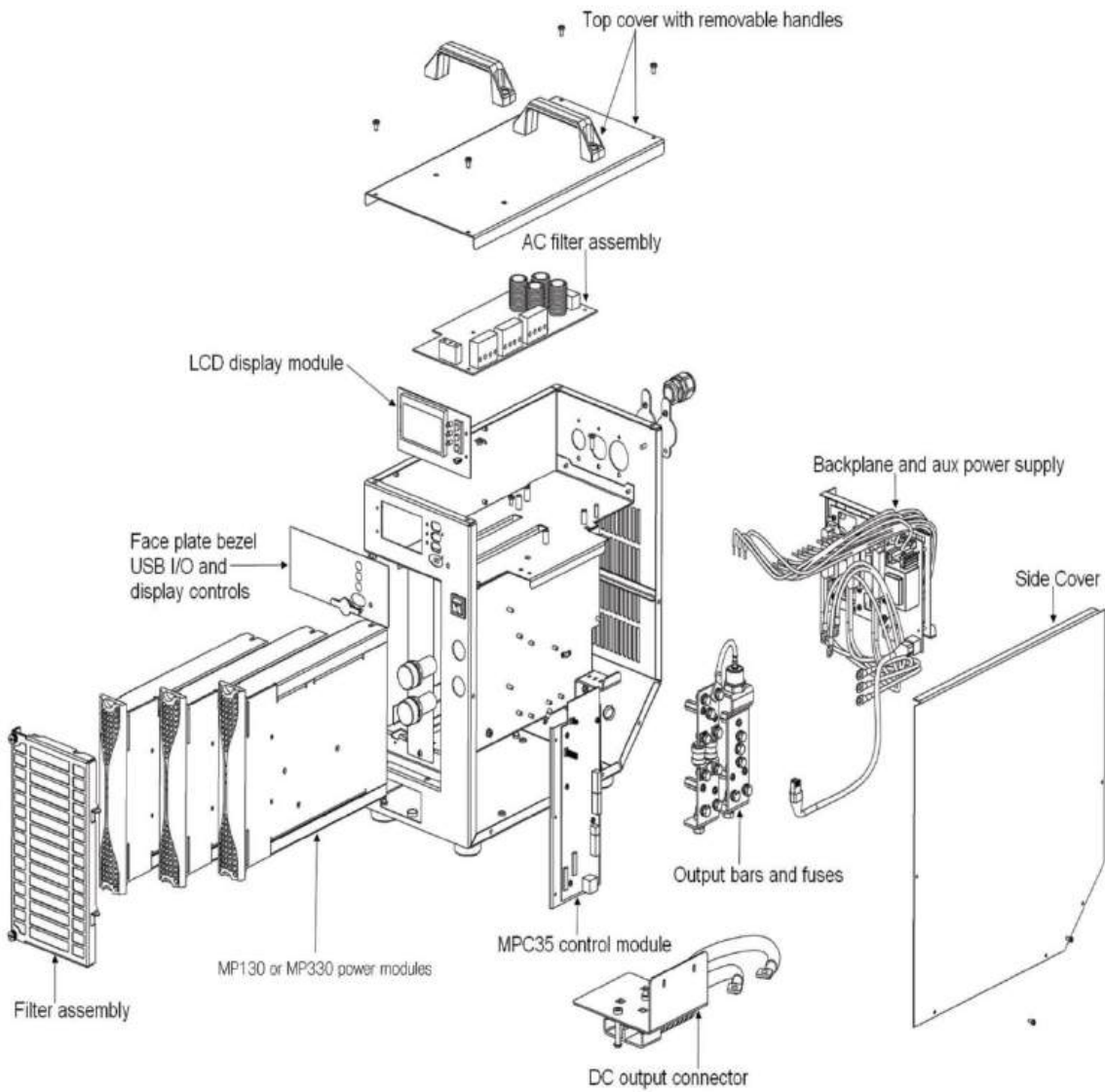







Problem	Possible Cause	Remedy
Over Discharged Battery.	Battery is <1.9Vpc at connection but recovers within 30 seconds of charge.	Typically due to the battery being quickly unplugged from the truck and plugged onto the charger without allowing the battery to recover. Regular occurrences might need investigation of work practices.
Deeply Discharged Battery.	Battery is still <1.9Vpc after 30 seconds of charge.	Check battery for faults.
Incorrect Battery.	Battery is not the correct voltage for the charger.	Check the configuration matches the battery, check the operator is not trying to plug an incorrect battery type onto the charger.
Bulk Charge Timeout.	The bulk charge part of the cycle is longer than expected.	Check the charger configuration matches the battery, check the battery for problems.
Finishing Charge Timeout.	The finishing charge part of the cycle is longer than expected.	Check that the configuration matches the battery, regular timeouts may indicate a problem with the battery.
Battery Disconnected.	Battery has been disconnected mid charge cycle.	Remind the operator if there is a need to disconnect the battery mid charge cycle they must first set the front panel toggle switch to STOP.
Reversed Battery.	A reverse polarity battery has been connected to the charger.	Correct the incorrect battery wiring and replace the blown charger output fuse(s).
Inability to set a 36V configuration to greater than 46A or a 48V config greater than 35A.	Charger only has a 10A AC input lead.	Upgrade the AC input circuit and remove the hardware AC current limit function.

Exploded View



22. Exploded View

Spare Parts

Image	Description
	MP130 Module
	MP330 Module
	3 Across Backplane Assembly
	SM31 Large Display Assembly
	Voltage Sensor
	MPC35 Main Board Assembly
	FS3 AC Filter and Voltage Selection Assembly
	Stud Diode 150A 300V
	Fuse HRC180A 150VDC 240VAC
	Front Control Panel Membrane
	USB Hole Plug
	Carry Handle

Spare Parts

Image	Description
	Mounting Bracket
	Case Foot
	FS3 Cabinet
	FS3 Lid
	FS3 Side Panel
	DC Output Loom
	Blanking Plate Oval
	Blanking Plate Conduit
	Welded Filter Assembly
	Front Panel Green Indicator
	Front Panel Red Indicator
	Front Panel Rocker Switch

Maintenance

Provided it is correctly installed in an appropriate location and is not abused, the charger will require little maintenance. The only requirement is to monitor the air inlet filter at the front of the charger for dirt accumulation. The charger modules internal to the charger housing require a good supply of cooling air during the charge cycle and a blocked filter will affect the cooling. A blocked filter could lead to the charger turning down its maximum output to prevent overheating of the charger modules. An extremely blocked filter could cause longer charge times, inability to charge the battery correctly or premature wear of the charger modules.

Service Interval

The recommended service interval is 6 months but this will vary depending on the location of the charger and the number of charge cycles performed. The fans in the charger modules only run during charging and are speed controlled. If the charger output is small the fans will only be turning slowly. At full power there is a considerable requirement for cooling air and the fans will be working hard with considerable hot air being exhausted from the rear of the charger. The exhaust air from the rear of the charger should never be restricted. The intermittent nature of the fans results in a long fan service with no scheduled replacement of fans being required.

Intake Filter

The filter material is an electrostatic polypropylene type that is easy to clean with compressed air to blow out any accumulated dirt and dust. Before attempting to clean the filter it is necessary to remove it from the housing by unscrewing the two captive screws and unhinging the filter from the housing. The electrostatic filters provide a good compromise between filtering and clogging, but a small quantity of dust will enter the charger modules during normal operation. A small quantity of dust in the charger modules will generally not cause problems, however excessive accumulation or where the material ingested is corrosive, conductive or wet will cause issues, resulting in premature wear of the charger modules.



Service & Warranty

Service

If both the RED and GREEN indicators are flashing there has been an Urgent Alarm that has prevented the charge cycle from completing. Take note of the error displayed on the display and contact your servicing battery dealer or call DC Power Technologies (DCPT) at 1-844-ECO-CHRG for assistance.

If the RED indicator is flashing, but the GREEN indicator is on steadily, the charge has completed satisfactorily but with a Non-Urgent Alarm. Contact DCPT only if this is occurring on a regular basis.

Warranty

DCPT warrants that the product is free from defects in material and workmanship and agrees to remedy any defect (or at its option replace the product) for a period of one year from the date of purchase. This warranty covers both parts and labour. Parts may be replaced under this warranty with new or remanufactured parts.

This warranty will not apply to any product that has been improperly installed, misused, abused, used in ways the product was not designed, altered or repaired in any way which may affect the performance or reliability of operation, sustained damage by power surges or electrical storms, or sustained shipping damage, or repaired by any unauthorised repair centre.

Please contact DCPT Customer Service to obtain a Returned Materials Authorisation (RMA) prior to shipping any products for repair. All shipments must be shipped prepaid and include proof of the date of your original purchase. Please include your name, address, phone number, email address and a brief description of the problem.

DCPT makes no other warranties, express or implied, including any warranty of fitness for a particular purpose. In no event shall DCPT be responsible for indirect or consequential damages or lost profits even if DCPT has been advised of the possibility of such damages. DCPT's sole obligation shall be the repair or replacement of a nonconforming product.

26. Service & Warranty

Warranty Certificate

ECO Charger FS3, FS5, FS9

DC Power Technologies Inc. warrants that this product is free from defects in the material and workmanship and agrees to remedy any defect (or at its option replace the product).

This warranty will not apply to any product that has been improperly installed (as described in the installation manual), misused, abused, used in the ways the product was not designed, altered or repaired in any way which may affect the performance of reliability of operation, sustained damage by power surges or electrical storms, or sustained shipping damage, or repaired by any unauthorized repair center.

This warranty covers both parts and labor. Parts may be replaced under this warranty with new or remanufactured parts.

1. **Products and Parts Warranted.** Subject to the exceptions listed below each Industrial Battery Charger is warranted for a specific period of time commencing from the date of sale by DC Power Technologies Inc. provided the charger is used in accordance with Enatel's Installation manual and instruction booklet. Exceptions to this warranty are as follows :

A. Terms and Conditions

Full Coverage, labor, travel, mileage & part replacement	2 years
Electronic parts only (fuses not included)	4 years

B. **Warranty Expense Limitation :** The maximum warranty expense DCPT will incur for any battery charger will be limited to the original purchase price of the battery charger.

C. AC Fuses, DC Fuses are not warranted unless found to be defective from the factory shipment.

2. **Commencement of Warranty Time Period.** The warranty periods indicated in the warranty schedule shall commence on the date of the sale from DC Power Technologies Inc.

3. **Persons Covered By Warranty.** DC Power Technologies Inc. extends this warranty only to the purchaser of the new equipment from DCPT or one of its authorized distributors. The products purchased under this agreement shall be used exclusively by the buyer and its employees and by no other persons; and therefore there shall be no third party beneficiary to this warranty.

4. **Altered Equipment.** Exception as authorized in writing, the warranty specified does not cover any equipment that has been altered by any party other than DCPT or its authorized dealer.

DC Power Technologies Inc. or Enatel Motive Power Ltd. Make no other warranties, express or implied, including any warranty of fitness for a particular purpose. In no event shall Enatel Motive Power or DCPT be responsible for indirect or consequential damages or lost profits even if Enatel Motive3 Power Ltd. Or DCPT have been advised of the possibility of such damages. Enatel Motive Power Ltd's / DCPT sole obligation to you shall be the repair or replacement of a non-conforming product.

WARNING : At all times safety must be considered an important factor in the installation, serving and operation of the product and skilled, qualified technical assistance should be utilized.

12432 Highway 99 Suite 72
Everett, WA 98204

Phone : 844-ECO-CHRG

www.DCPowerTechnologies.com



Specifications

FS3 Cabinet

Dimensions (in): 7.75W x 15.25D x 15.25H
Weight: 46 pounds (with 3 modules)

MP130 & MP330 Modules

AC Input	MP130	MP330
	Single phase 208/240V Three phase 208/240V	Three phase 480V
Nominal Input Voltage:	208-278V AC	380-480V AC
Operating Voltage Range:	90-300V AC	340-580V AC
Frequency Range:	45-65Hz >0.99PF	45-65Hz >0.92PF
Typical Efficiency:	Max. 93% @ 48V	Max. 93% @ 48V

DC Output

Range: 25-65V DC
60A DC output up to 50V
52A DC output to 57.6V

Ripple: <2mV

Broadband Noise: 2mV (<100hz)
200mV p-p (0-22Mhz)

Environmental Requirements

Ambient Temp. Range: -50°F to 104°F
(max. output power is derated above 122°F)

Storage Temperature: -68°F to 158°F

Humidity: 5-95% RH (non-condensing)

Compliances

UL Listed: E333392 - UL 1564

Safety: EN60950

EMC: EN61000-6-2, EN61000-6-4

AC Harmonics & Flicker: EN61000-3-2, EN61000-3-3

California Appliance Large Battery

Efficiency Program: Charger Systems



Contact your local dealer :



12432 Highway 99 Everett, WA 98204

Phone : 1-844-ECO-CHRG

Fax : 206-745-6077

www.DCPowerTechnologies.com



Manufactured by :



Copyright © 2013 Enatel Motive Power



APPENDIX VII

Honeywell Battery and Time Controller Operating Instructions

Sensing and Control

Honeywell Hobbs

Operating instructions

Battery and time controller Type 855

Please note!

Read this operating instructions carefully. In the event of questions, please contact your dealer or Honeywell Hobbs directly. Pay attention to the battery manufacturer's information and ensure that the installation and operating conditions described below are observed, since otherwise you may lose your warranty rights. Note in particular the information on the valid protection conditions in the section „Electrical connection“ or the protection regulations applicable in your country.

Type	Function
855	battery- and time controller
855.1	battery- and time controller with integrated service counter
855.5	battery controller
855.6	battery controller without relay contact

Functions

The Honeywell Hobbs battery- and time controller of type series 855 monitors the residual capacity at discharge of „traction-batteries“ and according to the type of the controller it also registers operating hours. An additional relay contact protects the battery against exhaustive discharge. Optionally the controller can be delivered with integrated service counter.

The controller is adjustable to the different battery types by the exhaustive discharge voltage via potentiometer on the rear of the unit. In order to activate a new adjustment the unit has to be reset! The factory set standard discharge voltage is **1,73 Vcell**. When choosing another adjustment we recommend to verify the correct discharge voltage. The residual capacity of the battery is monitored via a multi LED bar display (1 red LED, 7 yellow LEDs) (2). If the residual capacity falls under the limiting value „pre-warming“ (approx. **25 %**), the yellow LED starts flashing. When reaching the discharge voltage, the red LED (1) lights and the relay contact (pins 3+4) opens. In order to complete e.g. a lifting operation, the relay contact can be closed one more time for approx. **30s** by switching the key-operated switch off and on. There are 2 possibilities to reset the controller:

- battery is separated from the vehicle: reset voltage is **2,09Vcell** (reset voltage has to be exceeded for approx. 4 sec)
- battery remains in the vehicle while charging: reset voltage is **2,35Vcell**

The operating hours are indicated by a LC display. Type 855.1: The current status of the service down counter is indicated for a period of 5 sec. every time the unit is turned on (or the key switch is turned on resp.). After termination of the service time (service counter = 0), the service counting status is indicated in the LC display (flashes). The service counter is resettable via the reset button on the rear of the controller.

Exhaustive discharge voltage in Vcell (adjustable via potentiometer on the rear of the controller)

A	B	C	D	E	F	G	H	I	J	K
1,57	1,63	1,68	1,73	1,78	1,82	1,84	1,86	1,89	1,91	1,93

Delivery

The Honeywell Hobbs battery- and time controller is delivered with mounting staff and plug connector

Mounting

The controller is applicable for flush mounting in a boarding dash (or similar application).
Cutout Ø 52mm (optionally with adapter for cutout Ø 60mm order code:.... /735).

rear view:

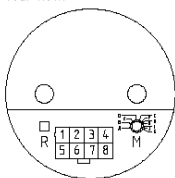

- 1: hour counter input -
- 2: key-operated switch +
- 3: relay +
- 4: relay -
- 5: battery -
- 6: hour counter input +
- 7: battery +
- 8: battery +
- M: adjustable potentiometer
- R: reset button (option)

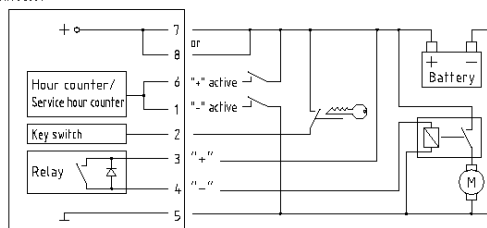

Electrical connection

The instrument must be installed by an authorised specialist. The relevant conditions must be observed, in particular the operating voltage of the controller must agree with the rated voltage of the battery (see rating plate).

Check the correct polarity of the relay contacts!

Function and operation

- 1 = red LED „Charge battery“
- 2 = yellow multi LED bar display for residual capacity of battery
- 3 = LC display for hour counter
- 4 = operation indication for hour counter

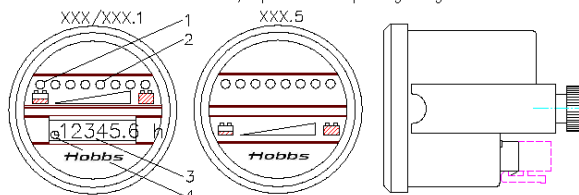

Technical data:

Operating voltage (V) tolerance ±25%:	12	24	36	48
Current consumption max. (mA):	50	35	35	25
EMC:	emission EN 55011 immunity EN 50082-2 (in case of excess-voltages that are above the approved EMC/EMI protection, we recommend a shielding from custom's side)			
Vibration:	EN 60068-2-34 (1g eff., 10-500Hz, 2,5h)			
Shock:	EN 60068-2-27 (30g, 18ms, 3 shocks), Continuous shocks EN 60068-2-29 (25g, 6ms, 1000 shocks)			
Relay contact:	opens when reaching discharge voltage, voltage free, breaking capacity 12VDC/5A, 24VDC/5A, 36VDC/3A, 48VDC/2A			
Signal inputs:	Minimum pulse duration 0,5 sec.			
Display:	multi LED bar display (8 LEDs), LC-Display 6 digits (4,5mm)			
Counting range:	hour counter up to 99999,9h service counter (option) up to 9999h			
Time divergence:	max. 0,02%			
Ambience:	-30°C to +70°C, max. 95% humidity			
Protection class:	IP65 frontal			



APPENDIX VIII

Declaration of Conformity



EU Declaration of Conformity

Model Number(s) eJP-3, eJP-3L
Product Type/Name: Electric Towbarless Tug
Serial Number(s): Enter serial number(s)

Declaration: Tronair has assessed the equipment described above against the Essential Health and Safety Requirements of one or more Directives. Based on this assessment, the equipment described above is deemed to comply with the directive(s) listed below.

This declaration of conformity is issued under the sole responsibility of the manufacturer.

Directives: European Machinery Directive 2006/42/EC

Standards: EN ISO 12100-1:2003 Safety of machinery – Basic concepts, general principles for design
 BS EN 12312-7:2020 Aircraft ground support equipment – Specific requirements – Part 7: Aircraft movement equipment
 EN 1915-1 2013 Aircraft ground support equipment – General requirements – Part 1: Basic safety requirements

Markings: 

The technical documentation for the machinery is available from:

Mr. Joel Nunn
 34 Epirus Road, SW6 7UH, London, UK
 Email: jnunn@tronair.com

Location of Issue: Tronair, 1 Air Cargo Parkway East, Swanton, OH 43558

Certificate: EU_DoC_02-7805C0111

Identification of person empowered to sign on behalf of the Manufacturer:

 Quality Assurance Representative

Enter a date
 Date

