

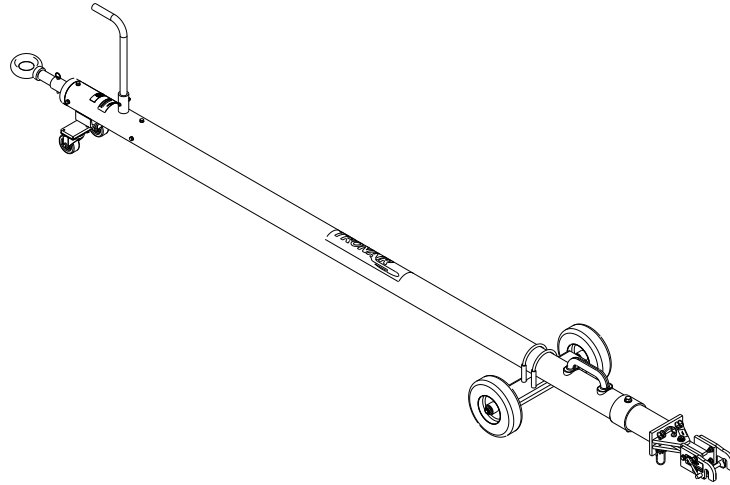

# OPERATION & SERVICE MANUAL



**Model: 01-1186-0000**  
**Custom Towbar**  
**Challenger CL-600**



03/2007 – Rev. 10

REVISION	DATE	TEXT AFFECTED
09	06/2004	New illustration Cover and Parts List
10	03/2007	Added CE marking



**TABLE OF CONTENTS**

	<b><u>PAGE</u></b>
<b>1.0 DESCRIPTION</b> .....	<b>1</b>
1.1 SPECIFICATIONS .....	1
<b>2.0 SAFETY INFORMATION</b> .....	<b>1</b>
2.1 GENERAL.....	1
<b>3.0 OPERATION</b> .....	<b>2</b>
3.1 LANDING GEAR ASSEMBLY.....	2
3.2 PRELIMINARY CHECKLIST.....	2
3.2.1 Towbar.....	2
3.2.2 Towing Head.....	2
3.3 USAGE PROCEDURE.....	2
3.3.1 Aircraft Attachment.....	2
3.3.2 Tug Attachment.....	2
3.3.3 Couplers.....	3
3.3.4 Towing Operation.....	3
<b>4.0 TRAINING</b> .....	<b>4</b>
4.1 TRAINING REQUIREMENTS .....	4
4.2 TRAINING PROGRAM .....	4
4.3 OPERATOR TRAINING .....	4
<b>5.0 PROVISION OF SPARES</b> .....	<b>4</b>
5.1 SPARE PARTS .....	4
5.2 PARTS LIST AND ILLUSTRATIONS .....	4
<b>6.0 IN-SERVICE SUPPORT</b> .....	<b>4</b>
<b>7.0 GUARANTEES/LIMITATION OF LIABILITY</b> .....	<b>4</b>

Tronair towbars/heads must only be used with matching Tronair heads/towbars, and Tronair shear pins.

This product can not be modified without the written approval of Tronair, Inc. Any modifications done without written approval voids all warranties and releases Tronair, Inc., its suppliers, distributors, employees, or financial institutions from any liability from consequences that may occur. Only Tronair OEM replacement parts shall be used.

## 1.0 DESCRIPTION

The Tronair Model 01-1186-0000 custom Towbar is designed for towing Challenger CL-600, 601 or 604 Aircraft manufactured by Bombardier Aerospace.

The custom towbar has an aircraft attachment by machined hooks on the towing head to the nose landing gear tow point. There is a handle and an eyebolt at the end of the towbar for towing.

### 1.1 SPECIFICATIONS

**Aircraft Application:** Challenger CL-600, 601, or 604 manufactured by Bombardier Aerospace

**Maximum Aircraft Gross Weight:** 44,000 lbs (19.9 Metric tons)

**Dimensions:**

**Length** 140-7/8 in (358 cm) From eyebolt centerline to aircraft attachment centerline

**Width** 22-7/8 in (58.1 cm)

**Height** 7-1/2 in (19.05 cm) From ground to aircraft attachment centerline

**Weight** 118 lbs (53.5 kg)

**Finish:** Blue Powder Coat

## 2.0 SAFETY INFORMATION

### 2.1 GENERAL

The Tronair Model 01-1186-0000 Custom Towbar is to be used for moving the Challenger CL-600, 601, or 604.

To ensure safe operation, please read the following statements and understand their meaning. This manual contains safety precautions which are explained as follows. Please read carefully.



**WARNING!** Warning is used to indicate the presence of a hazard that can cause **severe personal injury, death, and/or substantial property damage** if the Warning Notice is ignored.

**CAUTION!** Caution is used to indicate the presence of a hazard which will or can **cause minor personal injury or property damage** if the Caution Notice is ignored.



**WARNING!**

A damaged or bent towbar should not be used. Towbar should be repaired or replaced.



**WARNING!**

Tronair recommends the use of a towbar with a category 1 or category 2 tug and aircraft not exceeding 75,000 lbs gross weight. Using the towbar with aircraft weighing in excess of this specific limitation may result in excessive loads and stresses being applied to the towbar and/or the aircraft. These excessive loads may cause failure of the towbar which could cause damage (INCLUDING WITHOUT LIMITATION to the aircraft) and/or personal injury OR DEATH. **TRONAIR MAKES NO REPRESENTATION, WARRANTY OR GUARANTEE AS TO SUCH MISUSE AND DISCLAIMS ANY AND ALL LIABILITY FOR INJURY, LOSS OR DAMAGE ARISING FROM OR RELATING TO SUCH MISUSE.**

**3.0 OPERATION****3.1 LANDING GEAR ASSEMBLY**

Place landing gear assembly in desired location. Torque clamp nuts to 35 ft-lbs (47.5 N-m).

**3.2 PRELIMINARY CHECKLIST****3.2.1 Towbar**

- Check towing eye mounting bolts. Ensure fasteners are not loose or missing.
- Check towing eye for bending, excessive wear and/or deformity.
- Check shear pin. Ensure shear pin is not broken or missing; replace as required.

**WARNING!**

**Towing an aircraft using a towbar with a broken or missing shear pin may cause damage to the aircraft.**

**3.2.2 Towing Head**

- Check welds between side rails and head rail for cracks:
- Check welds between head plate, connector tube, and shear plates for cracks.
- Check fastener connection of towing head to towbar. Ensure the connection is not loose or missing.
- Check shear pin bushings. Ensure they are not cracked or chipped.
- Check hooks on towing head for bending or excessive wear.
- Check pivot bolt. Ensure connection is secure.
- Check axle locking mechanism, ensure operation of lock lever and cam. Inspect for excessive wear or damage. Replace if necessary.

**3.3 USAGE PROCEDURE****3.3.1 Aircraft Attachment**

- Ensure the sliding pin is locked in place using the ball lok-T pin.

**CAUTION!**

**It is recommended that your towbar be attached to the aircraft first, and then connected to the tug to avoid possible aircraft damage.**

**3.3.2 Tug Attachment**

- Use a pintle height so that the towbar is as level as possible during towing. Also, the pintle hook height should prevent contact of the towbar with the ground during towing.

**CAUTION!**

**Damage to the towbar or aircraft can result from an excessive towbar angle during towing operations. Reference Figure 1.**

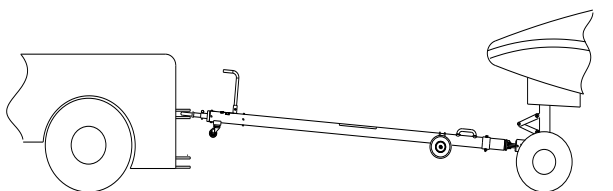

**Incorrect  
Excessive Towbar Angle**

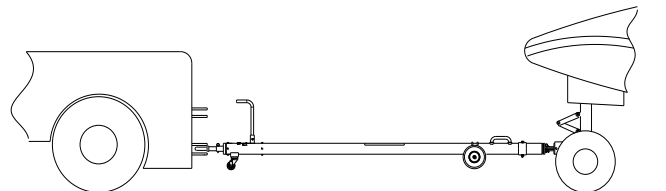

**Figure 1**

**Correct**

3.3 Usage Procedure continued on following page.

3.3 USAGE PROCEDURE (continued)

3.3.3 Couplers



**CAUTION!** Damage to the towbar or aircraft can result while towing with the following types of couplers:

- Lift Head
- Vertical Side Swing Latch
- Standard Duty Latch
- Swivel Hook

The couplers listed above are known to cause binding and failure in the eyebolt. Indicators of binding are wear on outside diameter of the eyebolt and indentation on the inside diameter of the eyebolt. **Reference Figure 2.**

Tronair recommends a telecoupler pintle hook arrangement. This arrangement is known to eliminate binding. Tronair offers a Standard Telecoupler, Model Number 01-1950-5000, for use on tugs. **Reference Figure 3.**

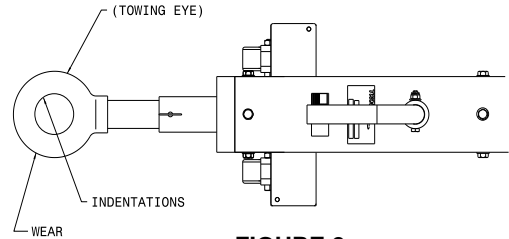

FIGURE 2

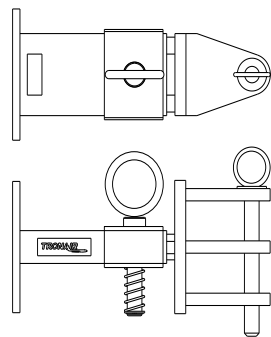

FIGURE 3  
01-1950-5000 Standard Telecoupler

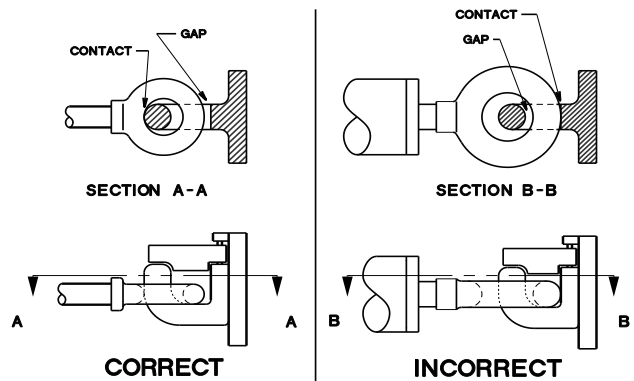

FIGURE 4

Damage to the towbar and/or aircraft can result by towing or pushing an aircraft with an incorrect size eyebolt or pintle pin. A correct size eyebolt will make contact with the pintle pin. A gap between the eyebolt outside diameter and the coupler face plate should be easily seen. An eyebolt which is too large will cause the eyebolt to make contact with the face plate of the coupler. When the eyebolt is too large for the coupler, a gap between the inside diameter of the eyebolt and the coupler face plate will be seen. **Reference Figure 4.**

To ensure proper towing and pushing, check to make sure the pintle pin diameter is not too long for the eyebolt's inside diameter. An approximate one-half inch ( $\frac{1}{2}$ " ) gap between the pin diameter and the eyebolt should be seen. If any of these conditions are not met, please contact Tronair for information to obtain a new coupler.

3.3.4 Towing Operation

Damage to the towbar or aircraft can result from pushing an aircraft while maintaining too sharp of an angle between the tug and the aircraft. Contact between the towbar weldment and the tug must be avoided. It is recommended that the angle between the tug and towbar not exceed 90°.

**Reference Figure 5**

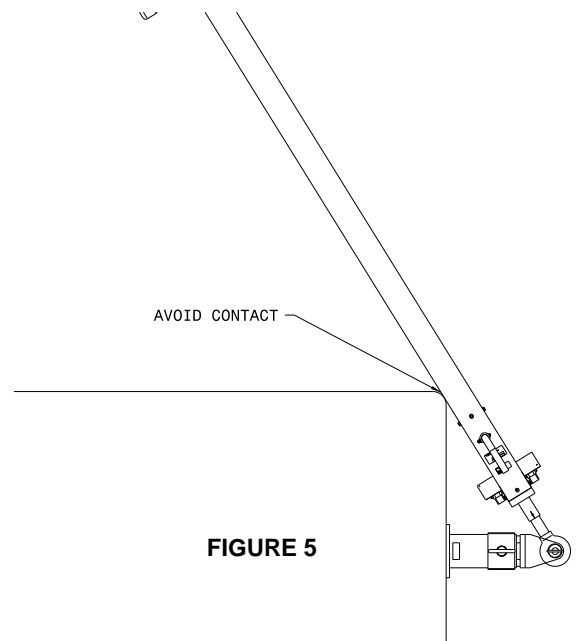

FIGURE 5



#### 4.0 TRAINING

##### 4.1 TRAINING REQUIREMENTS

The employer of the operator is responsible for providing a training program sufficient for the safe operation of the towbar.

##### 4.2 TRAINING PROGRAM

The employer provided operator training program should cover safety procedures concerning use of the towbar in and around the aircraft at the servicing location.

##### 4.3 OPERATOR TRAINING

The operator training should provide the required training for safe operation of the towbar.

**NOTE: Maintenance and Trouble Shooting are to be performed by the skilled and trained technician.**

#### 5.0 PROVISION OF SPARES

##### 5.1 SPARE PARTS

When ordering Replacement Parts/Kits & Spare Parts, please specify Model & Serial Number of your product.

Spare parts may be obtained from the manufacturer:

**TRONAIR, Inc.**  
1 Air Cargo Pkwy East  
Swanton, Ohio 43558 USA

Telephone: (419) 866-6301 or 800-426-6301  
Fax: (419) 867-0634  
E-mail: sales@tronair.com  
Website: www.tronair.com

##### 5.2 PARTS LIST AND ILLUSTRATIONS

Reference following pages for ordering information of Replacement Parts and Kits.

#### 6.0 IN-SERVICE SUPPORT

Contact Tronair for technical services and information.

#### 7.0 GUARANTEES/LIMITATION OF LIABILITY

Tronair products are warranted to be free of manufacturing or material defects for a period of one year after shipment to the original customer. This is solely limited to the repair or replacement of defective components. This warranty does not cover the following items:

- a) Parts required for normal maintenance
- b) Parts covered by a component manufacturers warranty
- c) Replacement parts have a 90-day warranty from date of shipment

If you have a problem that may require service, contact Tronair immediately. Do not attempt to repair or disassemble a product without first contacting Tronair, any action may affect warranty coverage. When you contact Tronair be prepared to provide the following information:

- a) Product Model Number
- b) Product Serial Number
- c) Description of the problem

If warranty coverage is approved, either replacement parts will be sent or the product will have to be returned to Tronair for repairs. If the product is to be returned, a Return Material Authorization (RMA) number will be issued for reference purposes on any shipping documents. Failure to obtain a RMA in advance of returning an item will result in a service fee. A decision on the extent of warranty coverage on returned products is reserved pending inspection at Tronair. Any shipments to Tronair must be shipped freight prepaid. Freight costs on shipments to customers will be paid by Tronair on any warranty claims only. Any unauthorized modification of the Tronair products or use of the Tronair products in violation of cautions and warnings in any manual (including updates) or safety bulletins published or delivered by Tronair will immediately void any warranty, express or implied.

The obligations of Tronair expressly stated herein are in lieu of all other warranties or conditions expressed or implied. **Any unauthorized modification of the Tronair products or use of the Tronair products in violations of cautions and warnings in any manual (including updates) or safety bulletins published or delivered by Tronair will immediately void any warranty, express or implied and Tronair disclaims any and all liability for injury (WITHOUT LIMITATION and including DEATH), loss or damage arising from or relating to such misuse.**

### Parts List

When ordering replacement parts/kits, please specify model, serial number and color of your unit.

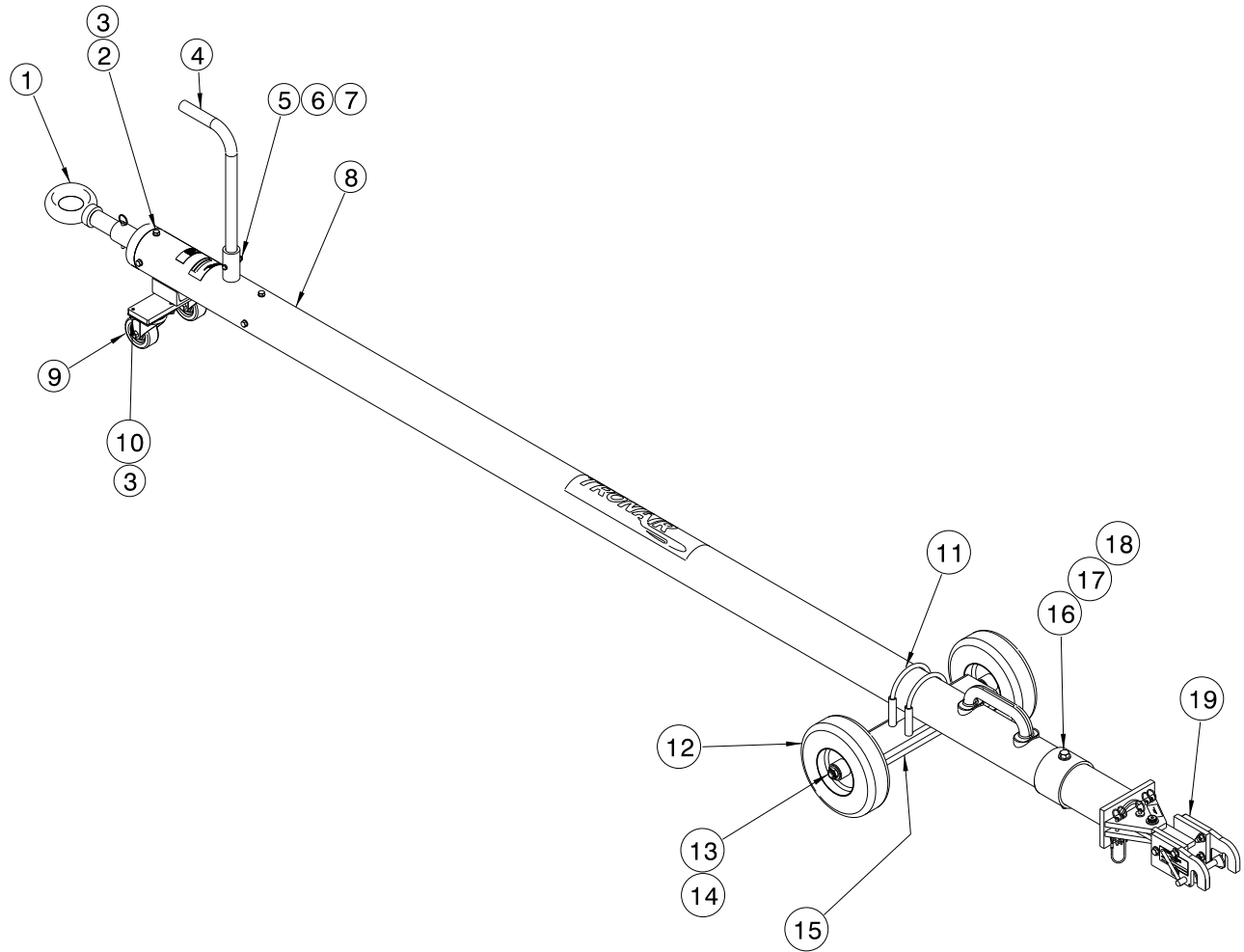

Item	Part Number	Description	Qty
1	Z-0107	Assembly, Shock/Shear	1
2	G-1420-106006	Bolt, Hex Head, Grade 8, 5/16 – 18 3/4" long	8
3	G-1251-1060R	Lockwasher, 5/16 Regular	12
4	TR-1857-01	Tube, Handle	1
5	G-1100-105520	Bolt, Hex Head, Grade 5, 1/4 - 28 x 2" long	1
6	G-1250-1050N	Flatwasher, 1/4 Narrow	1
7	G-1202-1055	Stopnut, 1/4 - 28 Elastic	1
8	Z-5945-014	Machining, Towbar	1
9	V-1000	Caster, Swivel	2
10	G-1100-106005	Bolt, Hex Head, Grade 5, 5/16 – 18 x 5/8" long	4
11	H-1537-08	Clamp, Muffler	2
12	U-1024	Wheel, Pneumatic Tire	2
13	G-1203-1105	Jamnut, 5/8-18 Elastic	2
14	G-1250-1100N	Flatwasher, 5/8 Narrow	4
15	Z-5643-01	Weldment, Axle Mounting	1
16	G-1100-109554	Bolt, Hex Head, Grade 5, 1/2 - 20 x 5 –1/2" long	1
17	G-1250-1090N	Flatwasher, 1/2 Narrow	2
18	G-1203-1095	Jamnut, 1/2 - 20 Elastic	1
19	X-1020	Assembly, Head	1

### Parts List

When ordering replacement parts/kits, please specify model, serial number and color of your unit.

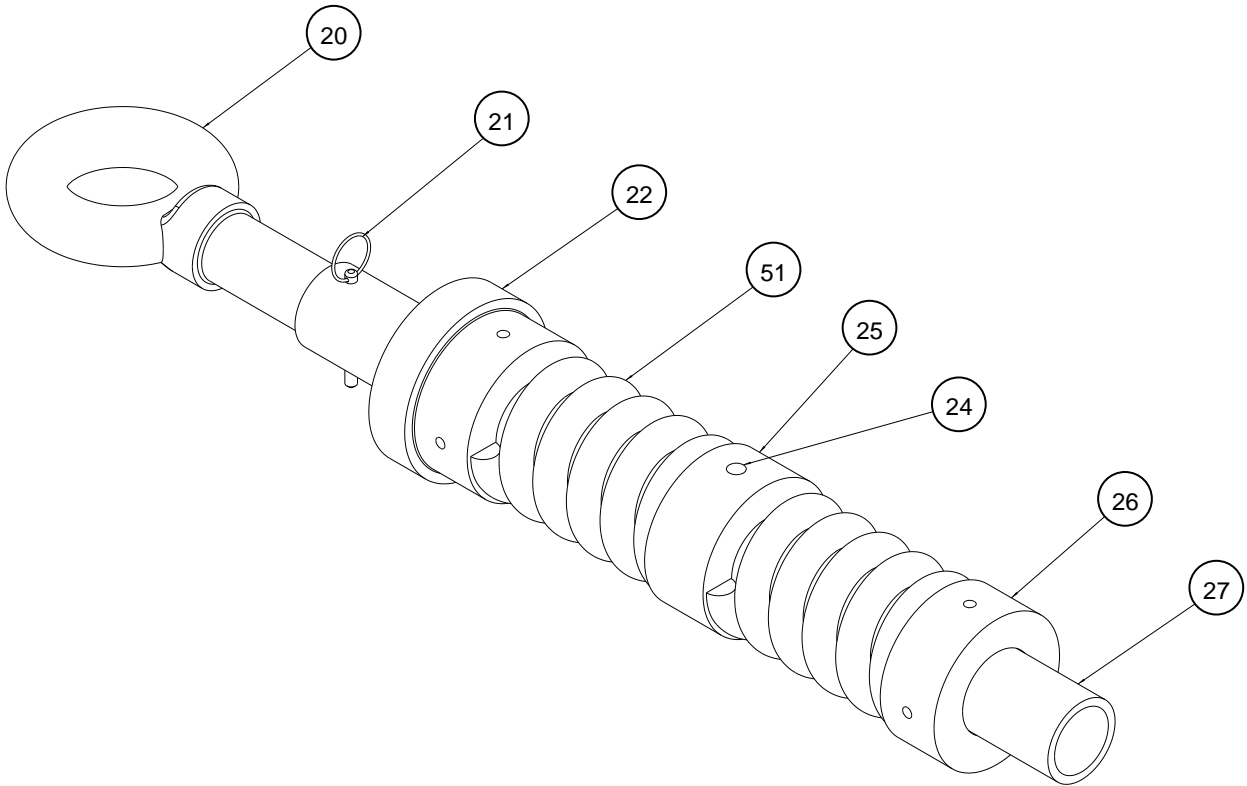

Item	Part Number	Description	Qty
20	Z-1453-05	Machining, Eyebolt	1
21	G-1307-0422	Pin, Shear (Tension/Compression)	1
22	B-018-02	Sleeve, Outer	1
24	G-1322-06	Pin, Drive-Lok Groove, 3/8" diameter x 3 1/2" long	1
25	B-019-02	Sleeve, Center	1
26	B-017-02	Sleeve, Inner	1
27	TR-1118-05	Tube, Outer Shear	1
51	B-016	Spring, Compression 3,700 lbs	2

### Parts List

When ordering replacement parts/kits, please specify model, serial number and color of your unit.

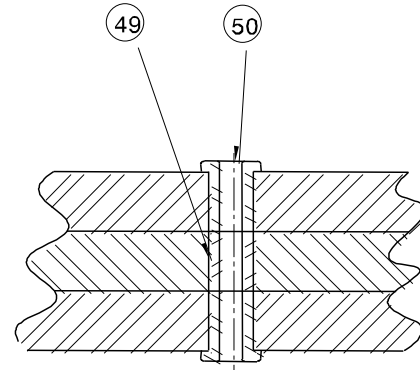
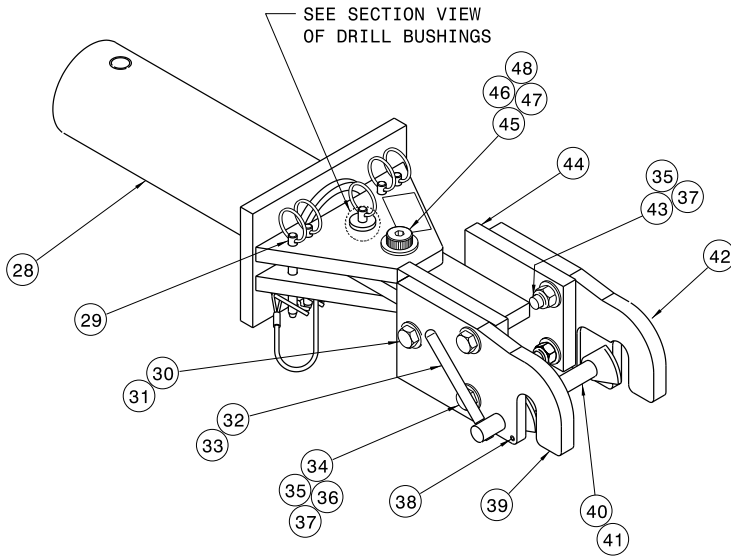

SECTION VIEW OF SHEAR PIN BUSHINGS

Item	Part Number	Description	Qty
28	Z-2060-01	Machining, Shear Plate	1
29	G-1452-22	Pin, Shear	5
30	G-1100-107510	Bolt, Hex Head, Grade 5, 3/8 -24 x 1" long	2
31	G-1251-1070R	Lockwasher, 3/8 Regular	2
34	G-1100-107520	Bolt, Hex Head, Grade 5, 3/8 -24 x 2" long	1
35	G-1250-1070N	Flatwasher, 3/8 Narrow	9
36	G-1250-1070W	Flatwasher, 3/8 Wide	1
37	G-1202-1075	Stopnut, 3/8 -24 Elastic	4
38	G-1300-16040	Pin, Roll, 5/32" diameter x 1/2" long	1
39	J-1268	Adapter, Axle	1
42	J-1269	Adapter, Axle	1
43	G-1100-107516	Bolt, Hex Head, Grade 5, 3/8 -24 x 1 3/4" long	3
44	Z-1492-01	Weldment, Head	1
45	G-1155-107216	Screw, Socket Head Shoulder	1
46	G-1250-1090N	Flatwasher, 1/2 Narrow	1
47	G-1250-1070N	Flatwasher, 3/8 Narrow	1
48	G-1202-1070	Stopnut, 3/8 - 16 Elastic	1
49	H-1725-03	Bushing, Headless	1
50	H-1724-03	Bushing, Head Press Fit	2
	<b>K-1380</b>	<b>Kit, Axle Locking Mechanism Replacement; consists of:</b>	
32	G-1300-25340	Pin, Roll, 1/4" diameter x 3 1/2" long	1
33	H-1205	Cover, Handle	1
40	Z-0130	Weldment, Axle Locking	1
41	G-1300-16050	Pin, Roll, 5/32" diameter x 5/8" long	1



## **APPENDIX I**

### **Declaration of Conformity**





## DECLARATION of CONFORMITY

The design, development and manufacture is in accordance with European Community guidelines

Custom Towbar  
01-1186-0000

Relevant provisions complied with by the machinery:  
2006/42/EC

Relevant standards complied with by the machinery:  
EN ISO 12100-1

Identification of person empowered to sign on behalf of the Manufacturer:

A handwritten signature in cursive script that reads "Patrick Finch". The signature is written in black ink and is positioned above a solid horizontal line.

Quality Assurance Representative