

**T-RX**  
Avionics Radio & Pulse Tester

**CCX**  
TECHNOLOGIES

# User Guide

Version 1.6.10



|  |           |
|--|-----------|
| <b>User Guide</b>  | <b>1</b>  |
| <b>Safety and Compliance</b>                                 | <b>6</b>  |
| <b>User Guide Versions</b>                                   | <b>7</b>  |
| <b>Product Information</b>                                   | <b>8</b>  |
| <b>Getting Started</b>                                       | <b>10</b> |
| What's in the box?   | 10        |
| Charge your T-RX™ internal battery                           | 10        |
| Connector Dust Covers  | 10        |
| How does it work?  | 11        |
| How to set up?   | 11        |
| How do I connect the external antenna?                       | 11        |
| How do I adjust the screen brightness?                       | 12        |
| How do I calibrate the T-RX™ touchscreen?                    | 13        |
| How do I change the T-RX™ touchscreen to High Contrast Mode? | 14        |
| How do I connect to an Ethernet network?                     | 15        |
| How do I connect to a Wi-Fi network?                         | 16        |
| How do I configure an Access Point network?                  | 17        |
| Remote Control and Reports                                   | 18        |
| Integration with ATEQ ADSE Air Data System                   | 21        |
| About System Page  | 22        |
| Check for upgrade  | 22        |
| About Support Page   | 23        |
| T-RX Controls  | 24        |
| How do I change the battery?                                 | 25        |
| <b>Getting Technical</b>                                     | <b>26</b> |
| Connector Info   | 26        |
| ARINC 429 Connector Pinout                                   | 27        |
| ARINC-429 Mating Connector                                   | 28        |

|                        |           |
|------------------------|-----------|
| LED Indicators         | 29        |
| <b>Test Details</b>    | <b>29</b> |
| User Input             | 30        |
| Antenna/Port Selection | 31        |
| Antenna Use            | 32        |
| VOR Test               | 33        |
| ILS Test               | 34        |
| Localizer Test         | 35        |
| Glideslope Test        | 36        |
| Marker Beacon Test     | 37        |
| VHF Com Generate Test  | 38        |
| VHF Com Receive Test   | 39        |
| VHF Receive Audio      | 40        |
| ELT 121.5 Testing      | 40        |
| FM Com Generate Test   | 41        |
| FM Com Receive Test    | 42        |
| FM Receive Audio       | 43        |
| UHF Com Generate Test  | 44        |
| UHF Com Receive Test   | 45        |
| UHF Receive Audio      | 46        |
| ELT 243 Testing        | 46        |
| HF Com Generate Test   | 47        |
| HF Com Receive Test    | 48        |
| HF Receive Audio       | 49        |
| SELCAL Test            | 50        |
| ELT 406 Test           | 51        |
| ELT(DT) 406 Test       | 52        |
| ELT(DT) Testing        | 52        |

|   |    |
|---|----|
| ELT 406 Test Config                                 | 53 |
| DME Test  | 54 |
| DME Test Config                                     | 55 |
| TCAS Test   | 56 |
| TCAS Test Config                                    | 57 |
| Transponder Mode A/C/S Test                         | 58 |
| Transponder Test Config                             | 59 |
| Transponder Mode A/C/S Test Item Descriptions       | 60 |
| Altitude Monitor Test                               | 62 |
| ADS-B OUT 1090ES Test                               | 63 |
| Airborne Mode                                       | 63 |
| Surface Mode  | 64 |
| ADS-B OUT 1090 Test Config                          | 65 |
| ADS-B 978 UAT Test                                  | 67 |
| ADS-B 978 Test Config                               | 68 |
| ADS-B 1090ES / ADS-B 978 UAT Test Item Descriptions | 69 |
| ADS-B IN 1090 Test                                  | 71 |
| ADS-B IN 1090 Test Config                           | 72 |
| MODE-S GICB Test                                    | 73 |
| MODE-S GICB Test Config                             | 75 |
| ANTENNA/COAX Test                                   | 76 |
| VSWR  | 76 |
| VSWR with Coax Loss Compensation                    | 77 |
| Distance to Fault with Connected Antenna            | 78 |
| Distance to Fault with Connected Load               | 79 |
| Distance to Fault with Unacceptable Coax Connection | 80 |
| Cable Loss  | 81 |
| Cable Loss with Defective Coax                      | 82 |

|   |            |
|---|------------|
| Return Loss                               | 83         |
| ANTENNA/COAX Test Controls                | 84         |
| ARINC 429 Test                            | 84         |
| RX Filtered                               | 85         |
| RX All                                    | 86         |
| RX Raw                                    | 87         |
| TX AHRS DIR                               | 88         |
| TX AHRS ACCEL                             | 89         |
| TX ADC/RADALT                             | 90         |
| Test Config                               | 91         |
| GPS Generator                             | 92         |
| GPS Test Config                           | 93         |
| GPS/SBAS Satellite Displayed Data         | 94         |
| GPS Generator Usage                       | 94         |
| GPS Generator Notes                       | 95         |
| Test Reports                              | 96         |
| View Report                               | 97         |
| Sample Test Report                        | 98         |
| <b>T-RX Hardware Specifications</b>       | <b>99</b>  |
| <b>T-RX RF Specifications</b>             | <b>100</b> |
| <b>Regulatory Compliance</b>              | <b>101</b> |
| <b>GPS Module Hardware Specifications</b> | <b>102</b> |
| <b>GPS Module RF Specifications</b>       | <b>102</b> |
| <b>Troubleshooting</b>                    | <b>103</b> |
| How do I connect to Remote Support?       | 104        |
| <b>License Code Activation Process</b>    | <b>105</b> |
| <b>FAQ</b>                                | <b>106</b> |
| <b>Contact Us</b>                         | <b>107</b> |

## Safety and Compliance

 This symbol refers to CAUTION items in the manual.

 This symbol indicates DC Power input requirements.

RF - Maximum T-RX and GPS Module RF output is less than 1 mW (0 dBm).

## User Guide Versions

| Version | Description  |
|---------|--|
| 1.6.10  | Add ELT(DT) support, new FM and UHF Com tests, ATEQ Air Data mode. Added note regarding GPS RF levels. Added Autostop and Pass/Fail for Xpndr, ADS-B. Added Antenna/Coax tests.<br>Software Version 1.6.10   |
| 1.6.9   | Changed A429 pin nomenclature. Expanded regulatory testing compliance section<br>Added transponder Class A or B selection<br>Added power input limits for RF ports<br>Software Version 1.6.9   |
| 1.6.8   | Updated for separate transponder Mode A and C MTL display and MTL difference.<br>Added note regarding simultaneous use of GPS Generator and XPNDR test.<br>Software Version 1.6.8  |
| 1.6.7a  | Clarified ILS signal range   |
| 1.6.7   | GPS SBAS range enabled. Option to enable/disable SBAS satellite. Description of SBAS automatic deselection. Added procedures for remote control of functions.<br>Software Version 1.6.7  |
| 1.6.6   | Frequency offset for Nav/Com added. VHF COM tone freq and mod level added. RF level uV values added. Transponder and ADS-B Country data added. Mode-S RI, FS, Max Airspeed, Time Sync, UF16 reply, SIL Supplement value added. Added note regarding optional dust covers. Software Version 1.6.6 |
| 1.6.1   | Minor content changes, add Safety page and T-RX Controls section of T-RX<br>Software Version 1.6.5   |
| 1.6     | Incorporates tests and features of T-RX Software Version 1.5.x/1.6.x   |
| 1.5     | Incorporates tests and features of T-RX Software Version 1.4.3   |
| 1.4     | Incorporates tests and features of T-RX Software Versions 1.4.1 and 1.4.2  |
| 1.3     | Incorporates tests and features of T-RX Software Version 1.3.4   |
| 1.2     | Incorporates tests and features of T-RX Software Version 1.3.3   |
| 1.1     | Incorporates tests and features of T-RX Software Version 1.3.2   |
| 1.0     | Initial Release  |

## Product Information

T-RX™ is a rugged portable tablet with a large color sunlight-readable touch-screen display, with an extended life battery, and an internal or external antenna that allows aircraft maintainers to quickly and easily test various aircraft avionics systems with ease.

T-RX™ is available in three variants. The standard tests for each variant are listed below, however, the T-RX™ Radio and Pulse are capable of adding additional optional tests to suit your needs. Simply contact CCX Technologies Inc. to order your additional optional tests.

### T-RX™ Radio

|                           |  |
|---------------------------|--|
| <b>VOR Generation</b>     | RF Level, Frequency, and bearing         |
| <b>ILS</b>                | Instrument Landing System components     |
| <b>Localizer</b>          | RF Level, Frequency, Deviation, and Tone |
| <b>Glideslope</b>         | RF Level, Frequency, and Deviation       |
| <b>Marker Beacon</b>      | RF Level and Tone                        |
| <b>VHF Com Generation</b> | RF Level, Frequency, and Tone            |
| <b>VHF Com Receive</b>    | Frequency, Power, Modulation Level       |

### T-RX™ Pulse

|                             |   |
|-----------------------------|---|
| <b>Transponder Mode A/C</b> | Power, Frequency, Receiver Sensitivity, SLS, Mode A code and Mode C altitude                    |
| <b>Transponder Mode S</b>   | Power, Frequency, Receiver Sensitivity, SLS, Mode A code and Mode C altitude, Mode S parameters |
| <b>ADS-B OUT 1090</b>       | ADS-B OUT parameters  |
| <b>MODE-S GICB</b>          | All MODE-S GICB Registers including ELS and EHS parameters                                      |

**T-RX™ RP+**

Includes all of the features of the T-RX™ Radio, T-RX™ Pulse and the tests below.

|                      |  |
|----------------------|--|
| <b>SELCAL</b>        | 32 Tone SELCAL generation in HF and VHF Bands                |
| <b>ELT 406</b>       | 406MHz ELT power, frequency, and reply decoding              |
| <b>ADS-B OUT 978</b> | Receiver sensitivity, power, frequency, ADS-B OUT parameters |
| <b>ADS-B IN 1090</b> | ADS-B/TIS-B/ADS-R 1090 Traffic Target Generation             |
| <b>DME</b>           | DME distance/velocity testing                                |
| <b>TCAS</b>          | TCAS Traffic Target Generation                               |
| <b>ARINC 429</b>     | ARINC 429 Receive & Transmit testing                         |

**Optional Tests not included in T-RX™ RP+**

|                      |  |
|----------------------|--|
| <b>GPS GENERATOR</b> | GPS Generator (requires additional hardware) |
|----------------------|--|

## Getting Started

### What's in the box?

- T-RX™ w/Li-ion smart battery installed (Figure 1)
- Charging Cable



Figure 1

### Optional Accessory Kit includes:

- Nanuk case (Figure 2)
- External Antenna (Figure 5)



Figure 2



Figure 3



Figure 4



Figure 5

### Charge your T-RX™ internal battery

Your T-RX™ will arrive with the battery installed.

Connect your charging cable to the charging port (Item 8, Figure 6). Your battery will be fully charged when the middle LED stops blinking and is solid green.

### Connector Dust Covers

Your T-RX™ will arrive with dust covers on all connections except for the charging port. These covers are recommended for shipping but are optional during use. For environments where FOD is a concern, these covers can be left off during use and during storage in the shipping case.

## How does it work?

Press the power button (Item 1, Figure 6) to turn on your T-RX™. The first menu option at the top left section of the screen defaults to TESTS. Select the dropdown menu next to the TESTS menu and select the desired test function. Various configurable options for the selected test will now be available.

## How to set up?

### How do I connect the external antenna?

The T-RX™ has two internal antennas (automatically selected by frequency), but you may need to use the external antenna on certain occasions. Connect the provided external antenna to the TNC connector (item 6, Figure 6).

**NOTE:** For Com/VOR/ILS/ELT an external antenna will have higher gain than the internal antenna.

**NOTE:** The supplied external antenna is not appropriate nor is it calibrated for L-Band tests (Transponder, ADS-B, DME).

## How do I adjust the screen brightness?

Select the TESTS menu at the top left section of the screen. Select CONFIGURE/SETTINGS/DISPLAY. Slide the Backlight Brightness to the desired level.

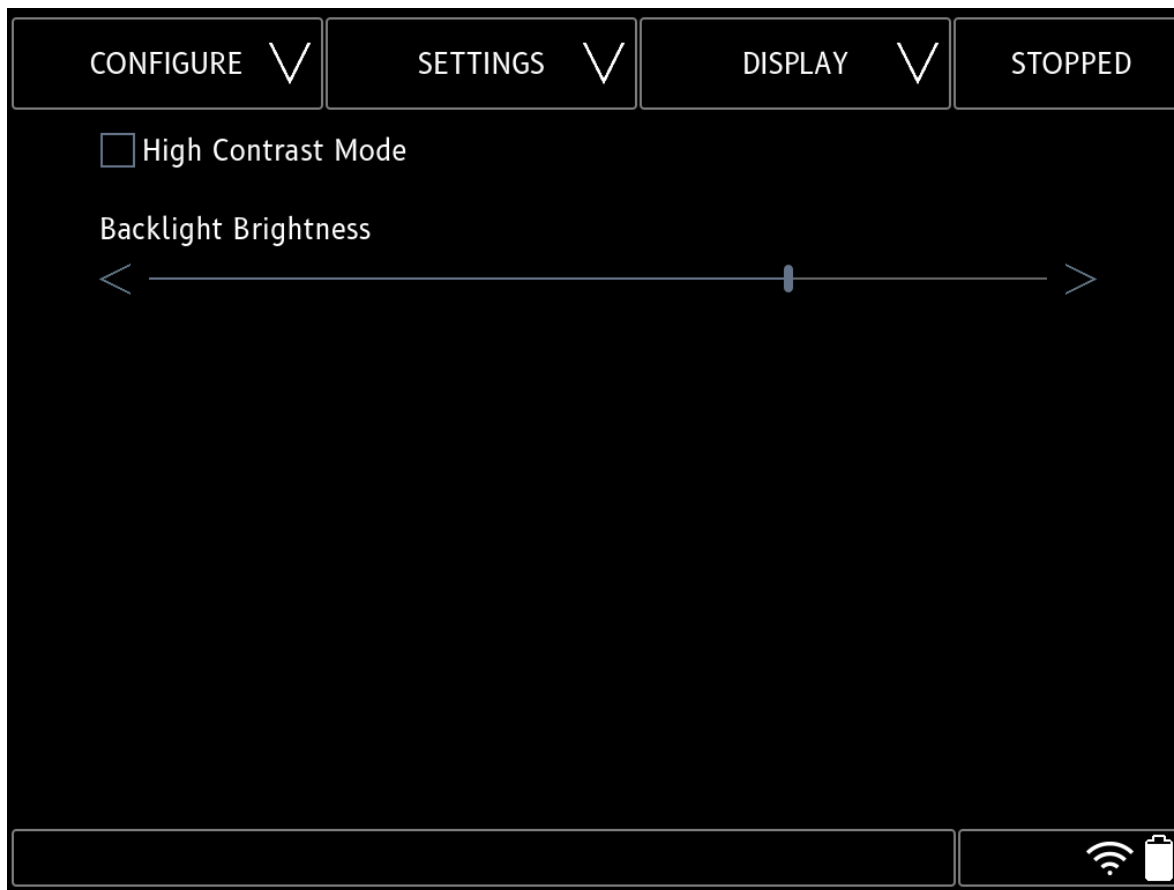

## How do I calibrate the T-RX™ touchscreen?

Screen calibration is performed using a web browser. Connect Ethernet 1 (Figure 6, Item 3) of the T-RX™ to a network, or connect via WiFi, an IP address will then be assigned.

Navigate to the CONFIGURE/SETTINGS/ETHERNET or CONFIGURE/SETTINGS/WIFI page (top left pull-down menu) and retrieve the T-RX™ IP address.

For automatic assignment of IP address, DHCP can be selected or manual IP address/length (in CIDR format) can be assigned.

From a device:

1. Launch a web browser
2. Enter the IP address assigned to the T-RX™ in the CONFIGURE -> WIFI or CONFIGURE -> ETHERNET page
3. Login to the portal with Username **admin** and Password **admin**
4. Select SERVICES -> T-RX CALIBRATION and select TOUCHSCREEN CALIBRATE or TOUCHSCREEN TEST
5. Follow instructions on T-RX™ screen to calibrate

## How do I change the T-RX™ touchscreen to High Contrast Mode?

Select CONFIGURE/SETTINGS/DISPLAY. Select the "High Contrast Mode" box.

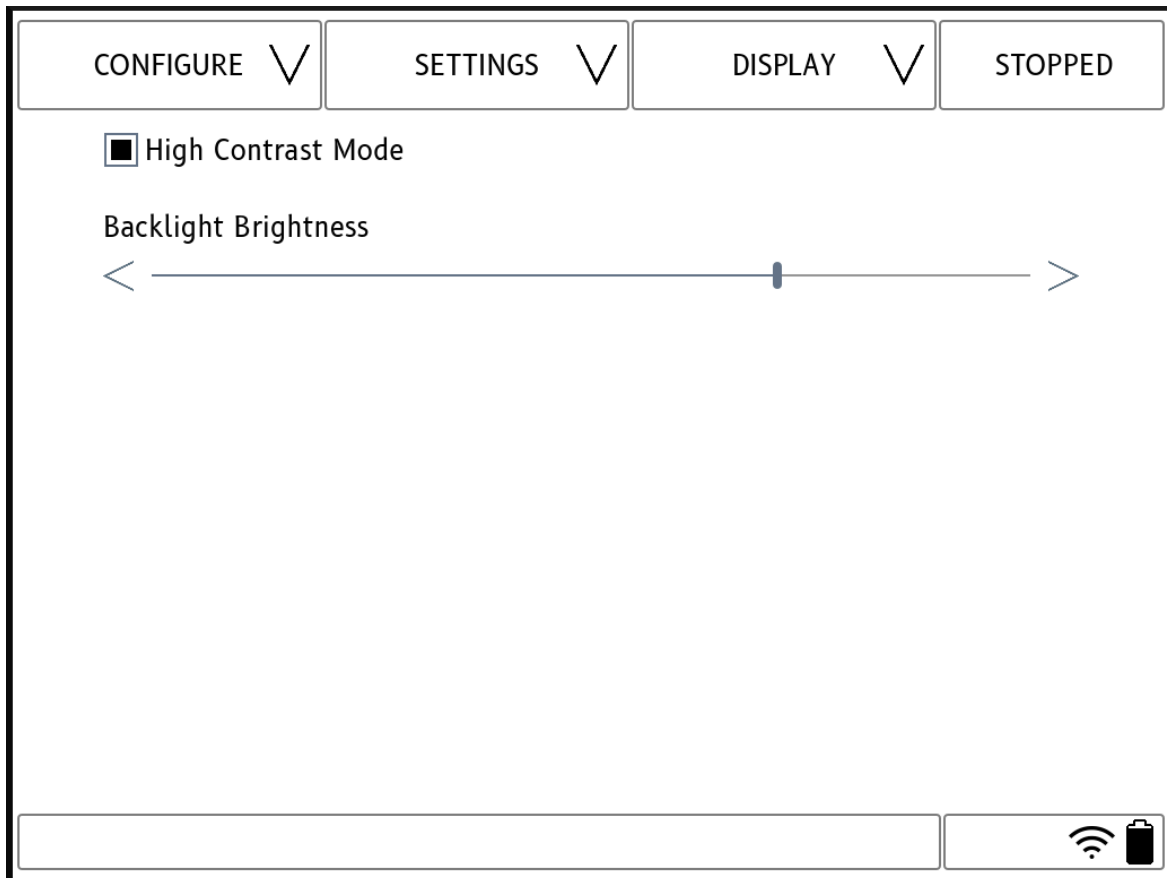

## How do I connect to an Ethernet network?

Connect an Ethernet cable to the top Ethernet port. Select CONFIGURE/SETTINGS/ETHERNET. An IP address will be automatically assigned if DHCP is selected, or if DHCP is deselected enter an address and subnet in CIDR format (x.x.x.x/xx).



## How do I connect to a Wi-Fi network?

Select CONFIGURE/SETTINGS/WIFI. Select Enable Client and DHCP. Enter up to 2 SSID and WPA/WPA2 passwords (password may be left blank for open networks). An IP address will be automatically assigned if DHCP is selected, or if DHCP is deselected enter an address and subnet in CIDR format (x.x.x.x/xx).

If a suitable connection is not made in 1 minute, the timeout indicator will turn red and the enable selection should be cycled if a new connection is needed.

The screenshot displays the configuration interface for the T-RX™ device, specifically the Wi-Fi settings screen. The interface is dark-themed with white text and input fields. At the top, there are four tabs: CONFIGURE, SETTINGS, WIFI, and STOPPED. The WIFI tab is selected, indicated by a downward arrow. Below the tabs, there are two columns of settings. The first column contains SSID 1 (CCX), SSID 2 (ajk312), and IP Address (192.168.86.25/24). The second column contains SSID 1 WPA Password (\*\*\*\*\*), SSID 2 WPA Password (\*\*\*\*\*), and a checkbox for DHCP (checked). At the bottom, there are two radio buttons: Enable Client (checked) and Channel Scan Timed Out (unchecked). A status bar at the very bottom shows a Wi-Fi signal icon and a battery icon.

| CONFIGURE   | SETTINGS                                     | WIFI | STOPPED |
|---|--|------|---------|
| SSID 1  | SSID 1 WPA Password                          |      |         |
| CCX   | *****  |      |         |
| SSID 2  | SSID 2 WPA Password                          |      |         |
| ajk312  | *****  |      |         |
| IP Address  | <input checked="" type="checkbox"/> DHCP     |      |         |
| 192.168.86.25/24                                  |  |      |         |
| <input checked="" type="checkbox"/> Enable Client | <input type="radio"/> Channel Scan Timed Out |      |         |

## How do I configure an Access Point network?

Select CONFIGURE/SETTINGS/ACCESS POINT. Enter the SSID and WPA passwords, select the Operating Mode and Channel. Put the desired IP Address in the IP Address box. Select Enable Access Point, if the Access Point activates successfully then the indication circle turns green.

Note: IP Address of Access Point should be in a different subnet than WiFi network if both are enabled and active.

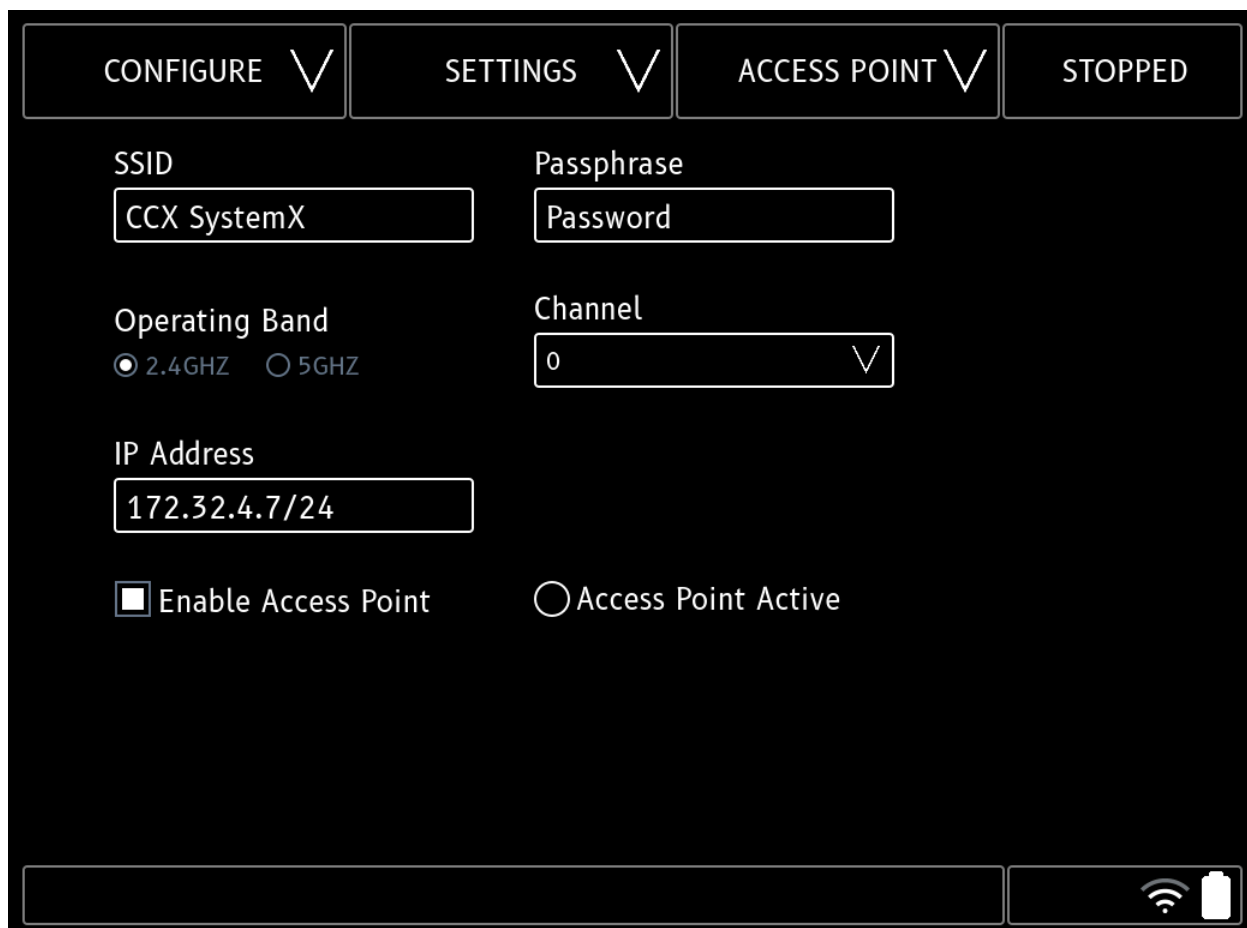

The screenshot displays the configuration interface for the T-RX device, specifically the ACCESS POINT settings screen. The interface is dark-themed with white text and input fields. At the top, there are four tabs: CONFIGURE, SETTINGS, ACCESS POINT (which is selected), and STOPPED. Below the tabs, the following settings are visible:

- SSID:** A text input field containing "CCX SystemX".
- Passphrase:** A text input field containing "Password".
- Operating Band:** Two radio buttons, "2.4GHZ" (selected) and "5GHZ".
- Channel:** A dropdown menu showing "0".
- IP Address:** A text input field containing "172.32.4.7/24".
- Enable Access Point:** A checked checkbox.
- Access Point Active:** An unchecked circle indicator.

At the bottom right of the screen, there are icons for Wi-Fi and battery status.

## Remote Control and Reports

The T-RX™ may be operated remotely or Test Reports retrieved using a device with a web browser (PC, laptop, tablet, smartphone). The connection to T-RX™ can be made using a WiFi network, Ethernet connection, or using the T-RX™ Access Point connection.

From a device:

1. Launch a web browser
2. Enter the IP address assigned to the T-RX™
  - a. Note: IP address will be presented in IP/Network format. Do not use the /XX Network portion.
3. Login to the portal with the Username: admin and Password: admin
4. Select a Test to run or a Report to view

Note: T-RX™ uses HTTPS browser connections. Without a certificate installed on the connecting device a SSL Certificate warning page will be encountered (see below). Selecting "ignore the upcoming browser warning" and selecting the subsequent browser pages to ignore the privacy warning will allow the login page to be displayed. Alternatively, the CCX local certificate can be installed on the device which will allow connections with no warnings. Select "CCX Technologies Certificate" to download the certificate. Use the device browser instructions for procedures to install the certificate.

### SSL Certificate Warning

You are attempting to access a resource through an SSL Tunnel (https) on a Local Network.

Unfortunately it isn't possible to register Local Network Names or IP Addresses with one of the public Certificate Authorities and as a result it isn't possible to use a certificate that is pre-registered with your browser to access this resource.

You can either import the CCX Technologies Certificate <sup>1</sup> or continue on and ignore the upcoming browser warning . You can safely instruct your browser to ignore this warning.

The Dashboard page after login will have selections to select a test to run or a report to view (view report interface will be similar to reports in the T-RX™ TEST INFO menu).

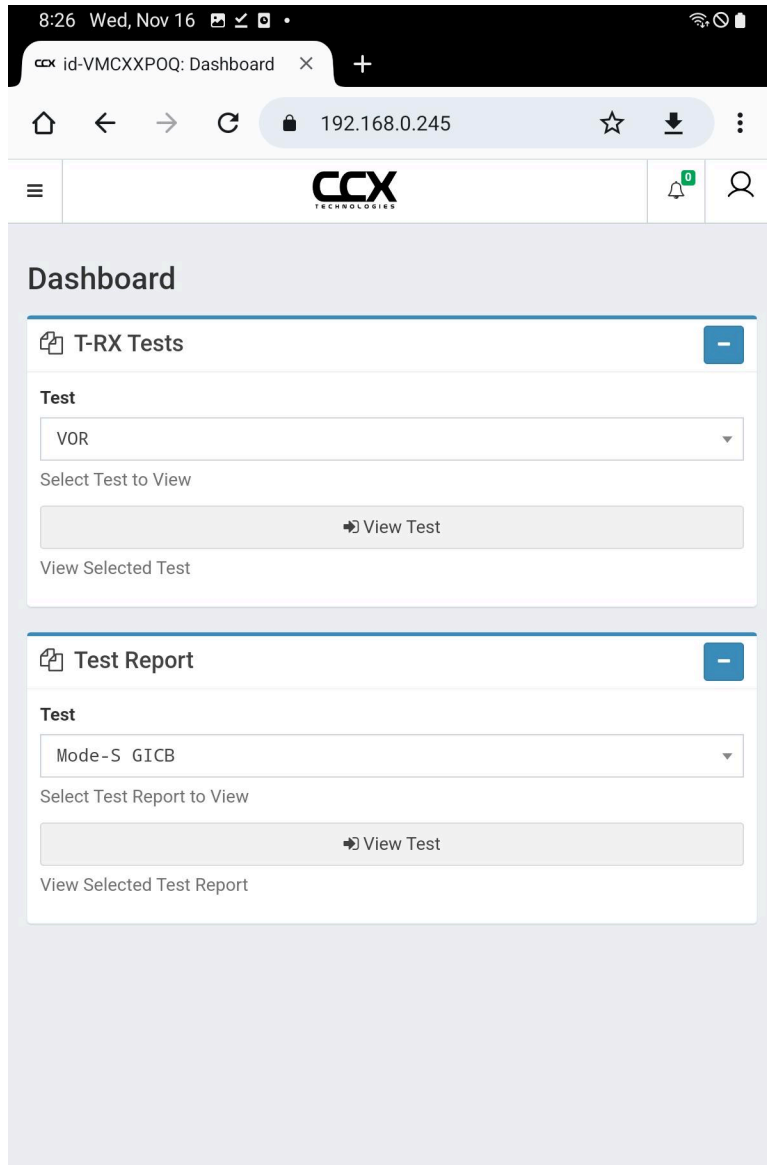

SystemX © CCX Technologies 2017-2021

Select a test to run and "View Test". To run a test, make selection changes as needed, select "Run Test", and select "Apply". To stop the test, deselect "Run Test" and select "Apply".

The screenshot displays a web browser window with the following details:

- Browser tab: id-VMCXXPOQ: VOR
- Address bar: 192.168.0.245/test-vor
- Page title: VOR
- Configuration fields:
  - Frequency (MHz): 108.0
  - RF Level (dBm): -40.0
  - RF Level (uV): 2236.06797749979
  - Bearing (deg.): 90.0
  - Direction: To
  - 1020 Hz Tone:
  - Fail: Normal
  - Frequency Offset (KHz): 0
  - Antenna: Eant
- Status indicators:  Run Test and  Running
- Action button: Apply

## Integration with ATEQ ADSE Air Data System

The T-RX™ XPNDR Test may be controlled by an ATEQ ADSE tablet while the tablet is also controlling the ADSE Pitot Static Tester. Follow these instructions to connect the T-RX™, ADSE, and ADSE Tablet:

1. Enable ATEQ Mode in the T-RX™ Configure -> About -> Support page.
2. Connect the T-RX™ WiFi connection to the WiFi Access Point of the ADSE.
3. Enable the T-RX™ Access Point in the Configure -> Settings -> Access Point page.
4. Once the Access Point page Active indicator turns green, the ADSE Tablet WiFi can be connected to the T-RX™ Access Point.

Refer to ATEQ ADSE User Manual for instructions on ADSE Tablet.

## About System Page

Select CONFIGURE/ABOUT/SYSTEM. T-RX Software Version , FPGA Version , Serial Number , Calibration Date and License Group are shown.

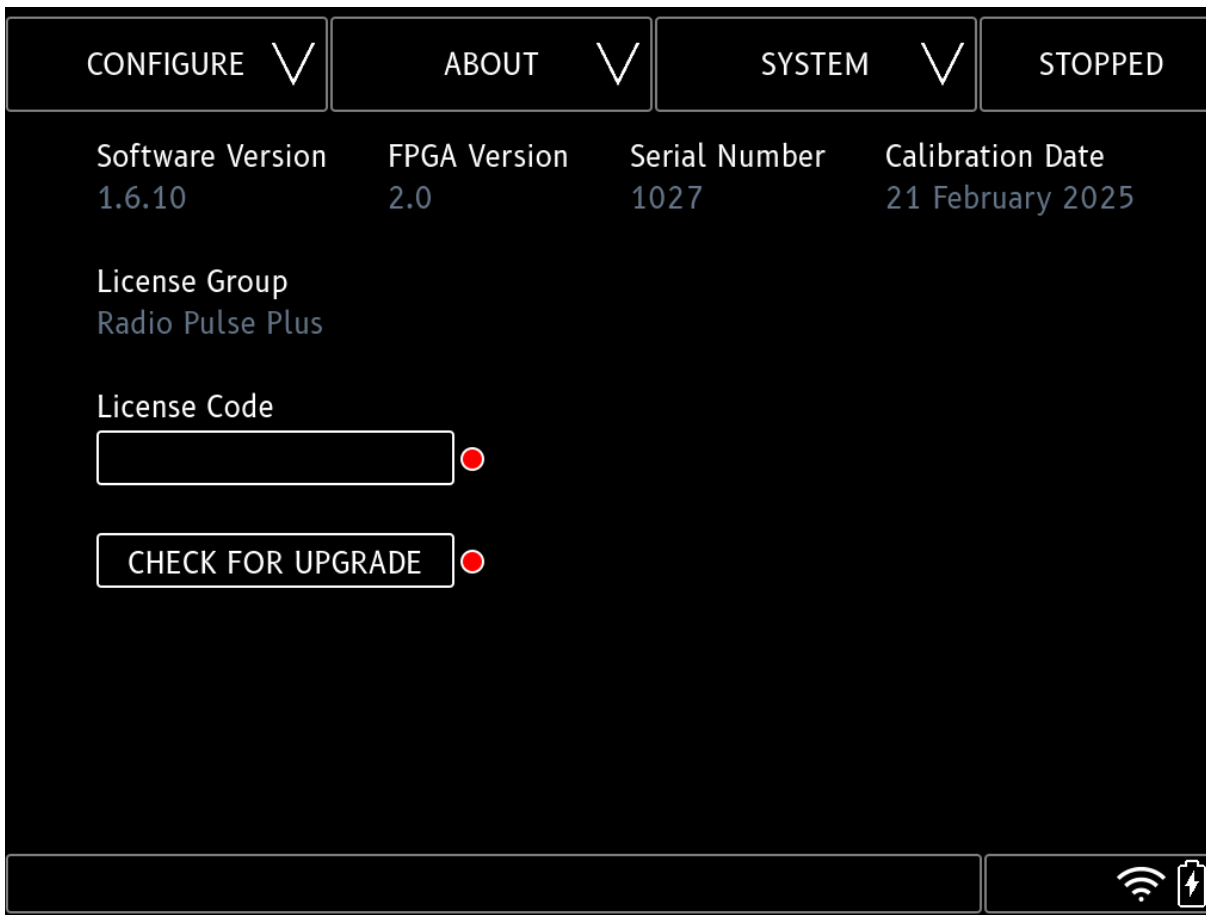

### Check for upgrade

Software can be upgraded from the public CCX upgrade server with software 1.5.x and higher. Select **CONFIGURE/ABOUT**. Select **CHECK FOR UPGRADE**. If there is an upgrade available, there will be a green indicator. A new option **UPGRADE FROM SERVER** will pop up to download and upgrade. Select **UPGRADE FROM SERVER**, it will start downloading. After completing the upgrade, it will show the Upgrade Complete message. The system will automatically reboot. **Note: The T-RX must have Internet access from WiFi or Ethernet in order to use this feature.**

## About Support Page

Select CONFIGURE/ABOUT/SUPPORT. T-RX CONTROLS will show an image with labels of the connections/controls and LEDs on the front of the T-RX.

USER MANUAL will show the complete T-RX User Manual.

Enable Remote Support will allow CCX Tech Support to remotely connect to the T-RX for troubleshooting. See Troubleshooting section for more details.

ATEQ mode enables a remote API to support XPNDR test control from an ATEQ ADSE Air Data System.



## T-RX Controls

CONFIGURE ▾
ABOUT ▾
SUPPORT ▾
STOPPED



|   |                               |   |
|---|-------------------------------|---|
| 1 | Power                         | On/Off  |
| 2 | USB                           | USB Headset or GPS Generator  |
| 3 | Ethernet 1                    | Used for retrieving test data and loading of software upgrades.   |
| 4 | Ethernet 2                    | Reserved for future use   |
| 5 | ARINC 429                     | ARINC 429: 1/2 RX 1, 4/5 RX2, 7/8 TX, 3/6/9/10 GND  |
| 6 | External Connection           | Connection to a receiver, or an external antenna  |
| 7 | Direct Transmitter Connection | Connects directly to a transmitter, such as a VHF com, Transponder, or DME. It can also be used for bench testing of these components. Also required if using a Transponder antenna coupler.<br><br>Note: Direct Port has a transmit 50 ohm load attached internally. For high power continuous transmit sources (VHF/HF Com) over 5W, observe a 30 second on, 1 minute off duty cycle. Pulse sources (Transponder, DME, ADS-B) can be used continuously. |
| 8 | Charging Port                 | Used for charging the internal T-RX™ battery  |

- 1 +

+

-

◀ ▶

↕



CONFIGURE ▾
ABOUT ▾
SUPPORT ▾
STOPPED



|            |                      |  |
|------------|----------------------|--|
| Top LED    | Power Incidicator    | Solid Green - On   |
| Middle LED | Charging Indicator   | Solid Green - Full Battery<br>Flashing Amber - Charging                            |
| Bottom LED | Test State Indicator | Solid Green - No Test<br>Solid Amber - Running Test<br>Solid Blue - Booting Device |

- 2 +

+

-

◀ ▶

↕



## How do I change the battery?

**Step 1** Using a #2 Phillips screwdriver, remove (4 ea) captive screws on the right end cap.

---

**Step 2** Slide the right end cap off.

---

**Step 3** Using the tab on the battery, pull the battery out.

---

**Step 4** Slide the replacement battery into the battery port.

---

**Step 5** Place the right end cap back onto the T-RX™.

---

**Step 6** Reinstall the (4 ea) screws that secure the end cap.

## Getting Technical

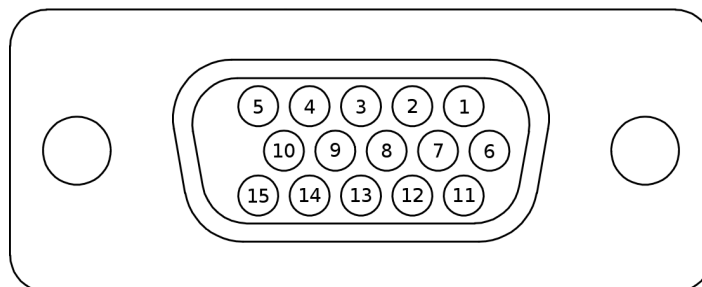

Figure 6 - T-RX™ Connectors

### Connector Info

|   |                               |  |
|---|-------------------------------|--|
| 1 | Power                         | On/Off   |
| 2 | USB                           | USB Headset or GPS Generator   |
| 3 | Ethernet 1                    | Used for retrieving test data and loading of software upgrades. T-RX™ is a DHCP client   |
| 4 | Ethernet 2                    | Reserved for future use  |
| 5 | ARINC 429                     | ARINC 429 TX/RX  |
| 6 | External Connection           | <p>Connection to a receiver, or an external antenna.</p> <p>⚠ Do not connect a transmitter to this port. Excessive RF energy can damage the T-RX RF input.</p>   |
| 7 | Direct Transmitter Connection | <p>Connects directly to a transmitter, such as a VHF com, Transponder, or DME. It can also be used for bench testing of these components. Also required if using a Transponder antenna coupler.</p> <p>⚠ Note: Direct Port has a transmit 50 ohm load attached internally. For high power continuous transmit sources (VHF/HF Com) over 5W, observe a 15 second on, 1 minute off duty cycle. Pulse sources (Transponder, DME, ADS-B) can be used continuously.</p> <p><b>WARNING: CW RF SOURCES OVER 25W MUST USE AN EXTERNAL ATTENUATOR TO LIMIT POWER AT DIRECT PORT TO &lt;25W!</b></p> |
| 8 | External Charging Port        | Used for charging the internal T-RX™ battery   |





## ARINC 429 Connector Pinout



| Pin | Function   | Pin | Function   | Pin | Function  | Pin | Function   | Pin | Function   |
|-----|------------|-----|------------|-----|-----------|-----|------------|-----|------------|
| 1   | A429 RX 1A | 2   | A429 RX 1B | 3   | GND       | 4   | A429 RX 2A | 5   | A429 RX 2B |
| 6   | GND        | 7   | A429 TX A  | 8   | A429 TX B | 9   | GND        | 10  | GND        |
| 11  | NC         | 12  | NC         | 13  | NC        | 14  | NC         | 15  | NC         |

## ARINC-429 Mating Connector

ARINC-429 signals in your installation can be broken out to an HD D-Sub connector and connected to the T-RX. The following parts are recommended for use in your breakout cable. Consult the part datasheets for assembly instructions and your wiring diagrams for equipment-specific ARINC-429 pinouts.

| Part Name                         | US Military Standard Part Number  | Photo   | Description   |
|-----------------------------------|-----------------------------------|---|---|
| Housing                           | M24308/4-11                       |    | Connector, 15-Pin Male, High-Density Plug or compatible |
| Pin                               | M39029/58-360                     |   | Contact Pin, Male, 22-28AWG, Crimp, Gold                |
| Insertion/<br>Extraction<br>Tools | M81969/1-04                       |  | Extraction, Removal & Insertion Tool                    |
| Crimper &<br>Positioner           | M22520/2-01<br>and<br>M22520/2-09 |  | Hand Crimper Tool, 22-28AWG, Side                       |

## LED Indicators



## Test Details

T-RX™ has an easy to use intuitive graphical user interface. To begin testing, start by ensuring the top left menu is set to "TESTS". Next press the menu to the right of "TESTS" to display all available test options for your T-RX™. Select the test you wish to perform, and adjust the options for that test as needed. When the options for your test are correctly set press "RUN" to begin the test.

## User Input



All sliders can be moved directly using the touchscreen, or by entering via an on screen numeric keyboard by touching the control value. For RF levels, enter as negative values (for example -15). Text fields will raise an alphanumeric keyboard.

Keyboard can be hidden by pressing the Keyboard Hide or Enter icons.

Some sliders have decrement/increment arrow keys, others may have presets.

## Antenna/Port Selection



|                         |  |
|-------------------------|--|
| <b>Internal Antenna</b> | Internal antenna is selected by de-selecting both EANT and DRCT  |
| <b>EANT</b>             | Select EANT for external antenna or connection to a receiver   |
| <b>DRCT</b>             | Select DRCT for Direct connection with internal 40 dB load/attenuator. Intended for connections with transmitters such as VHF/HF Com, Dme, Transponder, ADS-B OUT. Also appropriate for low loss antenna couplers. |

Note: Software 1.5.x and earlier antenna/port selections were independent settings for each test and DRCT could not be selected for any NAV tests.

Starting with 1.6.x software, antenna settings are persistent between tests. If DRCT port is selected in a NAV, COM, or SELCAL test, the generator output range is restricted to no more than -40 dBm due to the internal attenuator/load on the DRCT port.

## Antenna Use

Internal Antenna - Can be used for all tests, although gain will be low for HF frequencies. For HF COM, VHF COM, and NAV tests, a whip antenna connected to the EANT port will provide greater range. For L-Band/Pulse tests, the internal antenna is directional and the back of the T-RX™ should be pointed at the aircraft antenna.

Whip Antenna - Appropriate for HF, COM, and NAV tests. Connect to External Port (EANT). The whip antenna is **not suitable for Pulse applications**.

L-Band (Pulse) Antenna Couplers - A coupler which clamps onto the L-Band/Pulse antenna may be used, and is recommended for altitude correspondence testing to prevent interference with ATC or TCAS systems. See FAA SAFO 17002 for further information about proper test procedures when altimeter systems are exercised during testing. The combined Coupler and coax loss must be programmed in the application TEST CONFIG section as External Loss. Most couplers are very low loss (less than 1 dB), and the **Direct port connection must be used**.

L-Band Directional Antenna - CCX does not supply an external L-Band directional antenna, but the T-RX™ is compatible with any directional antenna with calibrated loss at the frequency of use.

## VOR Test

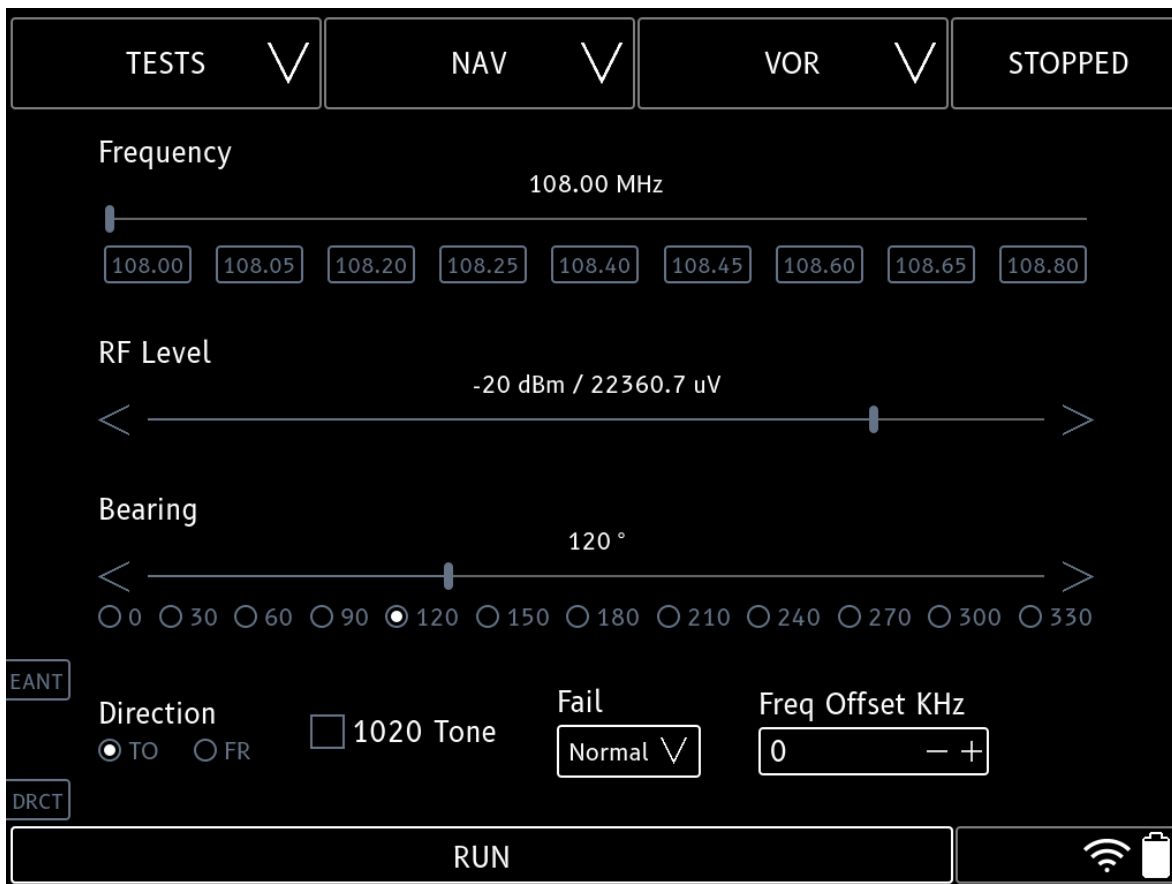

|                     |  |
|---------------------|--|
| Frequency (MHz)     | Select the desired frequency by selecting a preset, using the slider, or selecting frequency number and using keypad |
| RF Level (dBm / uV) | Set the RF level with the slider, < > decrement/increment arrows, or selecting level number and using keypad         |
| Bearing             | Select from a preset, slider, or selecting bearing number and using keypad   |
| Direction           | Select To or From  |
| 1020 Hz Tone        | On or off  |
| Fail                | Select from Normal, Ref, Var, or Both. Selecting Ref, Var, or Both will cause a VOR fail flag                        |
| Freq Offset         | Generated frequency can be offset for selectivity testing  |
| EANT                | Select EANT for external antenna or no selection for the internal antenna  |
| RUN/CANCEL          | Selecting RUN will output the signal continuously until CANCEL is selected   |

## ILS Test

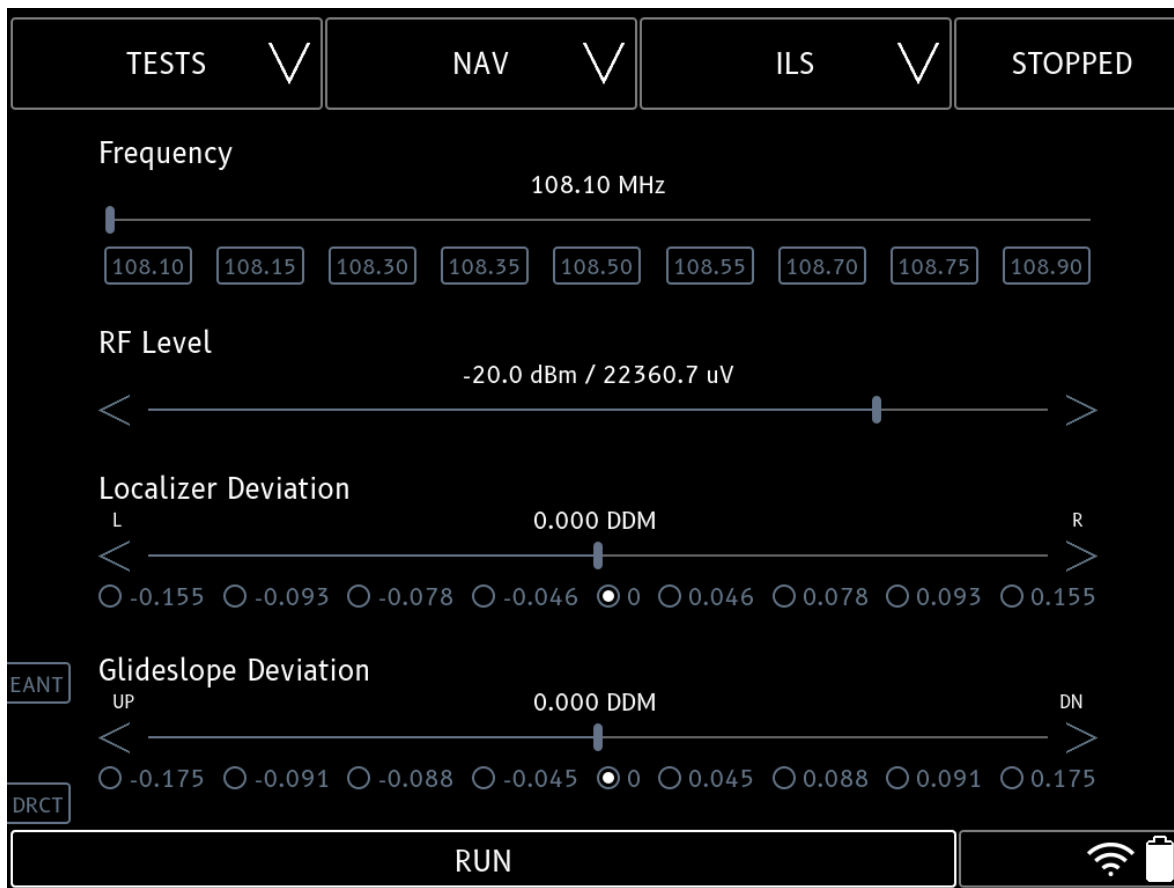

|                            |   |
|----------------------------|---|
| Frequency (MHz)            | Select the desired frequency by selecting a preset, using the slider, or selecting frequency number and using keypad  |
| RF Level (dBm / uV)        | Set the RF level with the slider, < > decrement/increment arrows, or selecting level number and using keypad. RF levels are -48dBm <-> 0 dBm, uncalibrated in ILS mode. |
| Localizer Deviation (DDM)  | Select from a preset, slider, or selecting DDM number and using keypad  |
| Glideslope Deviation (DDM) | Select from a preset, slider, or selecting DDM number and using keypad  |
| EANT                       | Select EANT for external antenna or no selection for the internal antenna   |
| RUN/CANCEL                 | Selecting RUN will output the signal continuously until CANCEL is selected  |

## Localizer Test

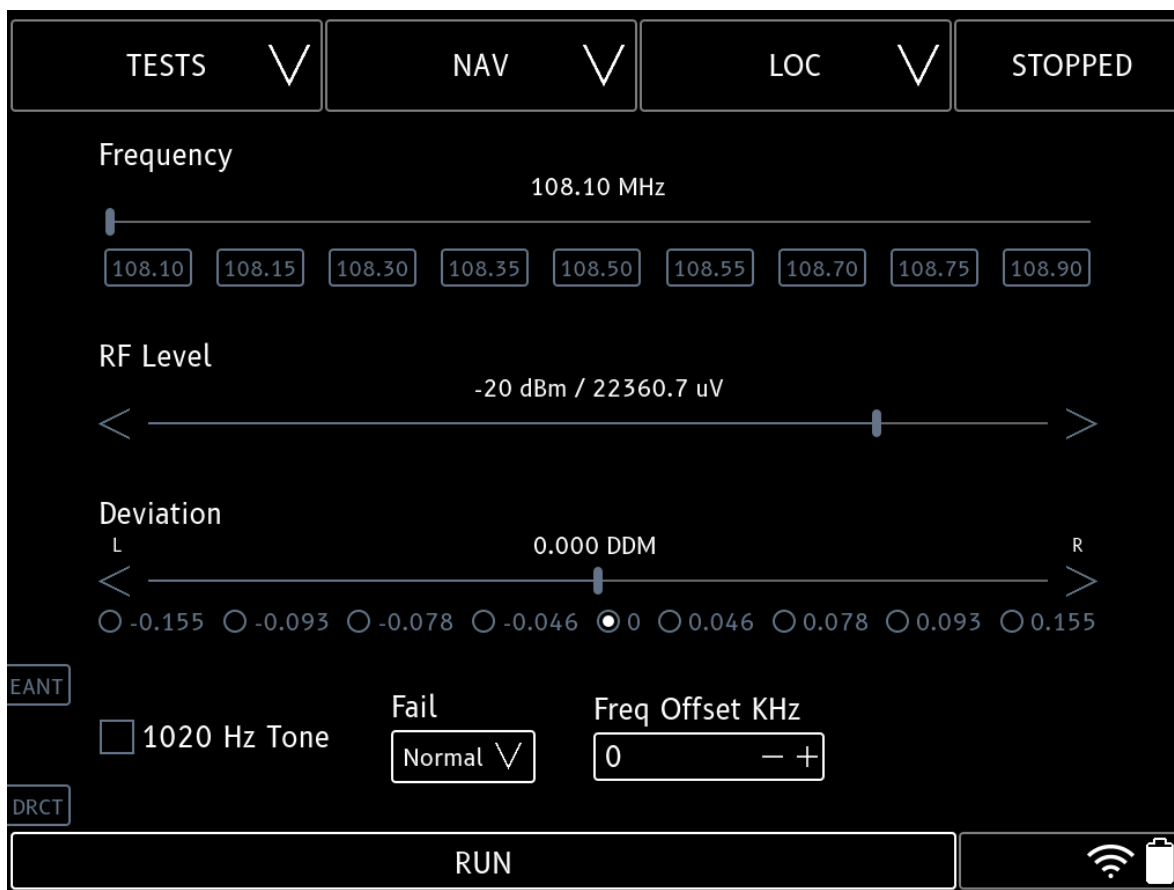

|                     |  |
|---------------------|--|
| Frequency (MHz)     | Select the desired frequency by selecting a preset, using the slider, or selecting frequency number and using keypad |
| RF Level (dBm / uV) | Set the RF level with the slider, < > decrement/increment arrows, or selecting level number and using keypad         |
| Deviation (DDM)     | Select from a preset, slider, or selecting DDM number and using keypad   |
| 1020 Hz Tone        | On or off  |
| Fail                | Select from NORMAL, 90HZ, 150HZ, or BOTH. Selecting 90HZ, 150HZ, or BOTH will cause an LOC fail flag                 |
| Freq Offset         | Generated frequency can be offset for selectivity testing  |
| EANT                | Select EANT for external antenna or no selection for the internal antenna  |
| RUN/CANCEL          | Selecting RUN will output the signal continuously until CANCEL is selected   |

## Glideslope Test

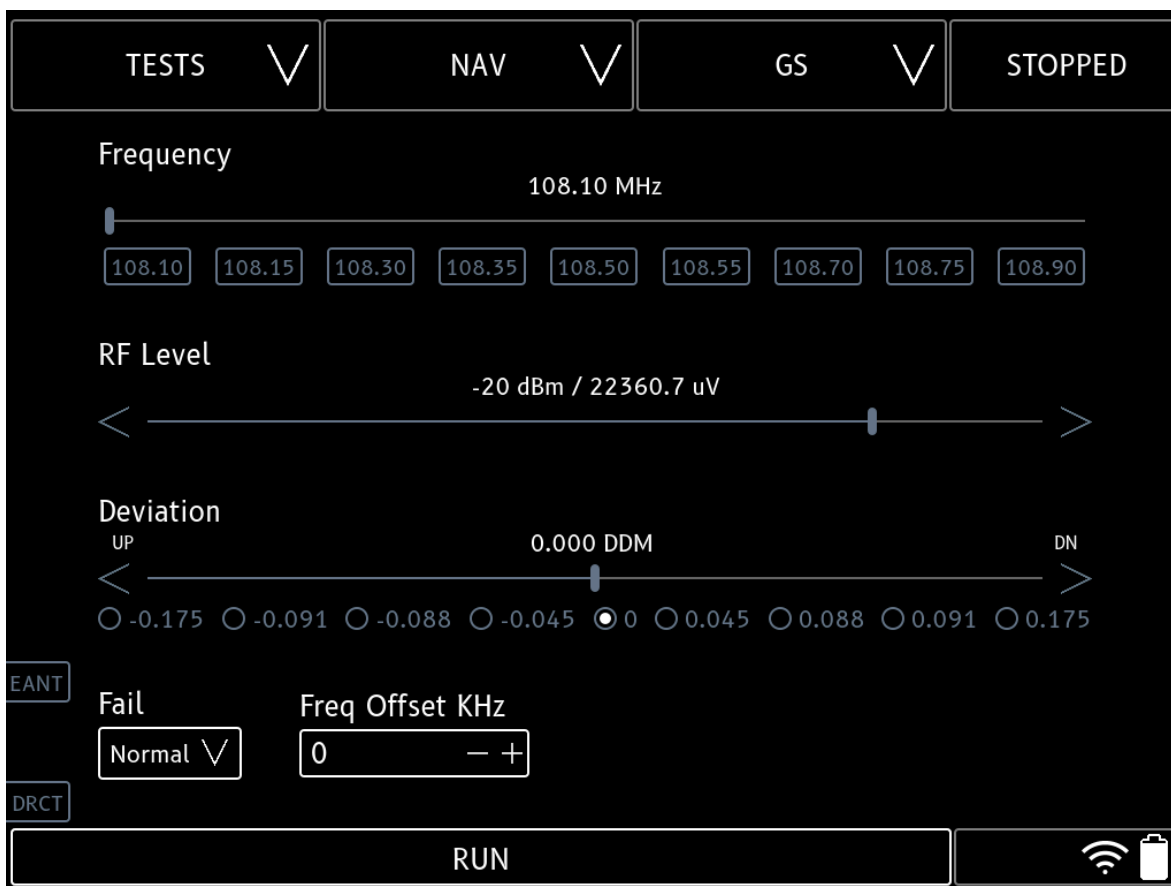

|                     |  |
|---------------------|--|
| Frequency (MHz)     | Select the desired frequency by selecting a preset, using the slider, or selecting frequency number and using keypad |
| RF Level (dBm / uV) | Set the RF level with the slider, < > decrement/increment arrows, or selecting level number and using keypad         |
| Deviation (DDM)     | Select from a preset, slider, or selecting DDM number and using keypad   |
| Fail                | Select from NORMAL, 90HZ, 150HZ, or BOTH. Selecting 90HZ, 150HZ, or BOTH will cause a GS fail flag                   |
| Freq Offset         | Generated frequency can be offset for selectivity testing  |
| EANT                | Select EANT for external antenna or no selection for the internal antenna  |
| RUN/CANCEL          | Selecting RUN will output the signal continuously until CANCEL is selected   |

## Marker Beacon Test

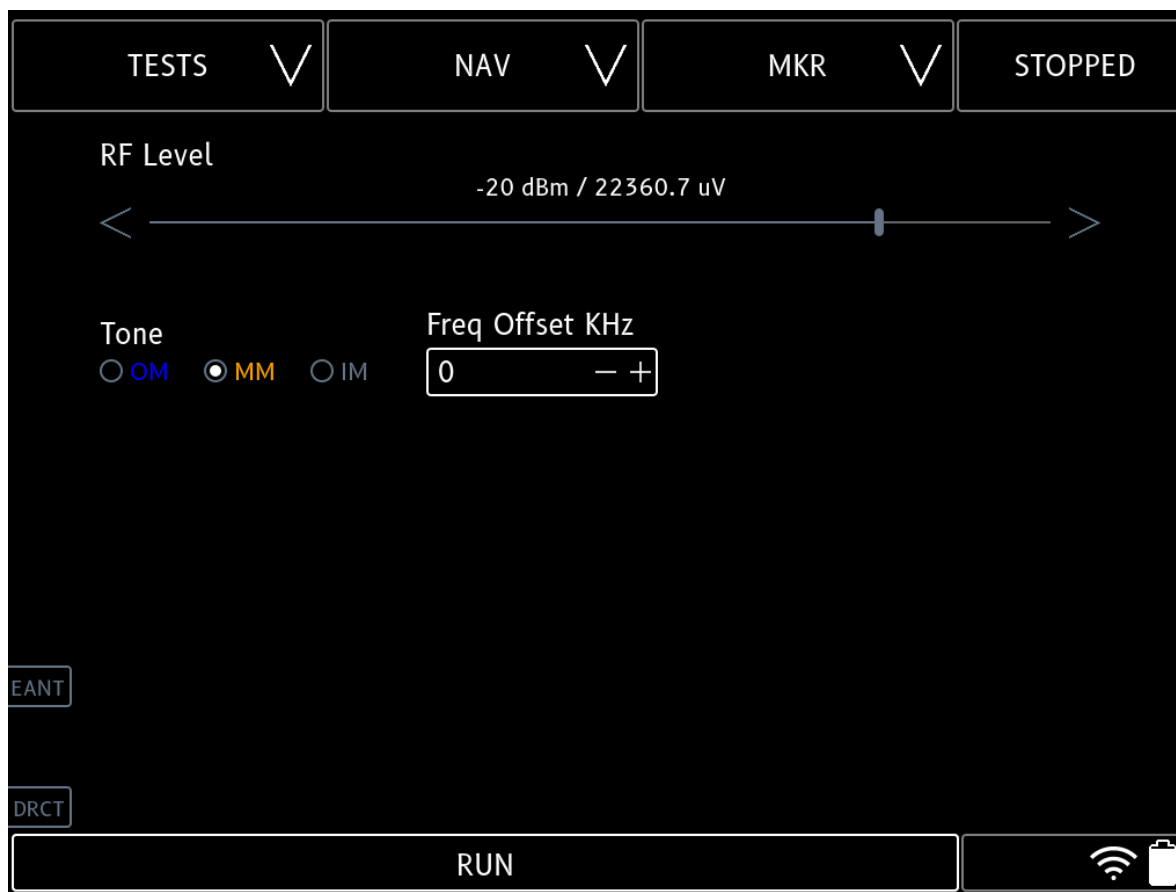

|                     |  |
|---------------------|--|
| RF Level (dBm / uV) | Set the RF level with the slider, < > decrement/increment arrows, or selecting level number and using keypad |
| Tone                | Choose from outer marker, middle marker, inner marker. Selection color matches Marker Annunciator color      |
| Freq Offset         | Generated frequency can be offset for selectivity testing  |
| EANT                | Select EANT for external antenna or no selection for the internal antenna                                    |
| RUN/CANCEL          | Selecting RUN will output the signal continuously until CANCEL is selected                                   |

## VHF Com Generate Test



|                     |  |
|---------------------|--|
| Frequency (MHz)     | Select the desired frequency or 8.33 KHz channel by using the slider, < > decrement/increment arrows, or selecting frequency/channel number and using keypad |
| RF Level (dBm / uV) | Set the RF level with the slider, < > decrement/increment arrows, or selecting level number and using keypad   |
| Tone                | On or off  |
| Tone Freq           | Modulation tones from 300 Hz to 12 KHz. 8/12 KHz used for Carrier Squelch testing  |
| Mod Level           | Modulation Index 30% - 90%   |
| Freq Offset         | Generated frequency can be offset for selectivity testing  |
| EANT/DRCT           | Select EANT for the external antenna, DRCT for a direct connection, or no selection for the internal antenna   |
| RUN/CANCEL          | Selecting RUN will output the signal continuously until CANCEL is selected   |

## VHF Com Receive Test



|                         |  |
|-------------------------|--|
| Frequency (MHz)         | Select the desired frequency or 8.33 KHz channel by using the slider, < > decrement/increment arrows, or selecting frequency/channel number and using keypad |
| EANT/DRCT               | Select EANT for the external antenna, DRCT for a direct connection, or no selection for the internal antenna   |
| RUN/CANCEL              | Selecting RUN will receive the signal continuously until CANCEL is selected  |
| Frequency Result        | Measured frequency with a resolution of 100 Hz   |
| Average Power Result    | Measured Average Power in dBm and Watts. Only displayed when Direct port is selected   |
| Peak Power Result       | Measured Peak Power in dBm and Watts. Only displayed when Direct port is selected  |
| RSSI Result             | A relative measure of received power when External or Internal port is selected  |
| Modulation Index Result | Measured Modulation percentage. Only accurate with single tone modulation  |

## VHF Receive Audio

A USB headset can be used to listen to transmitter modulation. Insert USB plug in T-RX™ USB receptacle before starting test.

## ELT 121.5 Testing

An ELT with 121.5 MHz output can be tested with the VHF Com Receive Test.

Test Setup:

- Select 121.5 MHz.

- Use Direct port

- Use Peak Power for ELT power

- Use USB headset for ELT modulation

## FM Com Generate Test

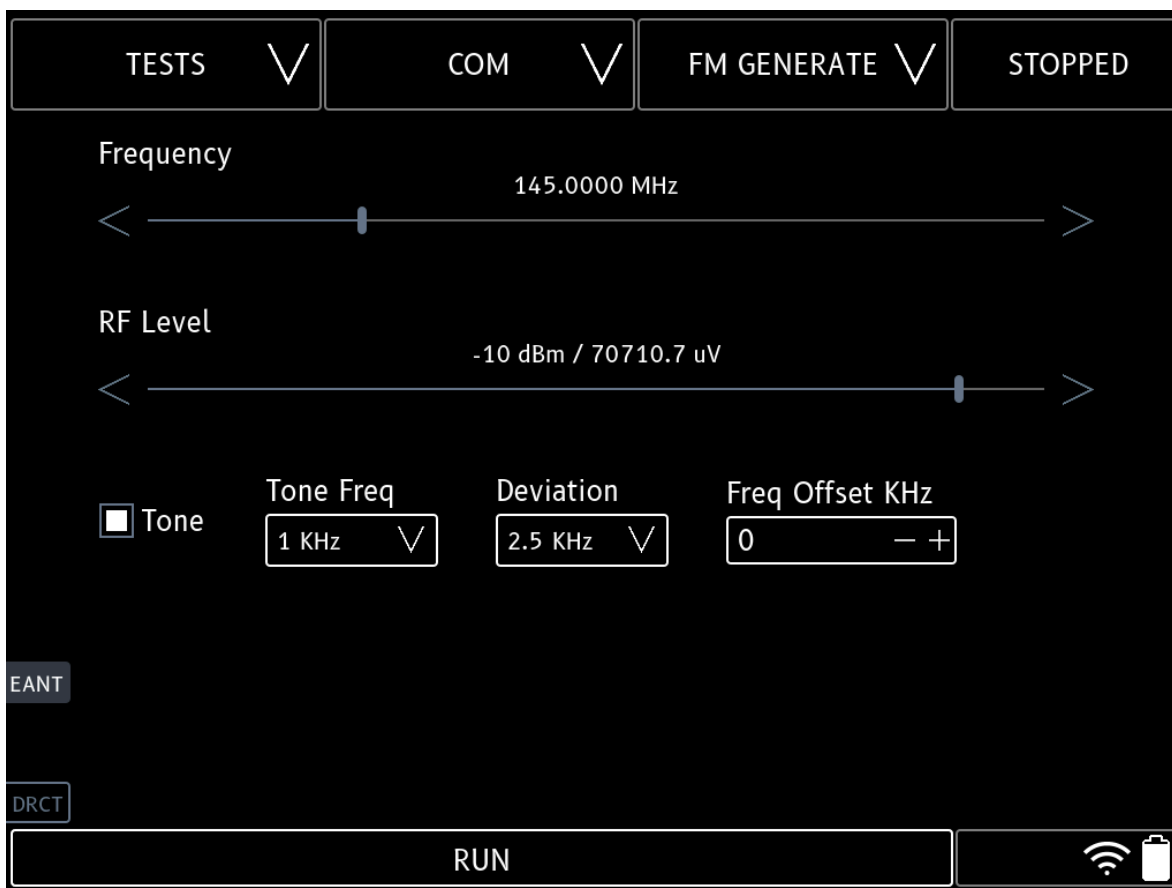

|                     |  |
|---------------------|--|
| Frequency (MHz)     | Select the desired frequency by using the slider, < > decrement/increment arrows, or selecting frequency/channel number and using keypad |
| RF Level (dBm / uV) | Set the RF level with the slider, < > decrement/increment arrows, or selecting level number and using keypad                             |
| Tone                | On or off  |
| Tone Freq           | Modulation tones from 300 Hz to 12 KHz.  |
| Deviation           | Modulation Deviation 2.5/5.0 KHz (Narrowband/Wideband)   |
| Freq Offset         | Generated frequency can be offset for selectivity testing  |
| EANT/DRCT           | Select EANT for the external antenna, DRCT for a direct connection, or no selection for the internal antenna                             |
| RUN/CANCEL          | Selecting RUN will output the signal continuously until CANCEL is selected   |

## FM Com Receive Test

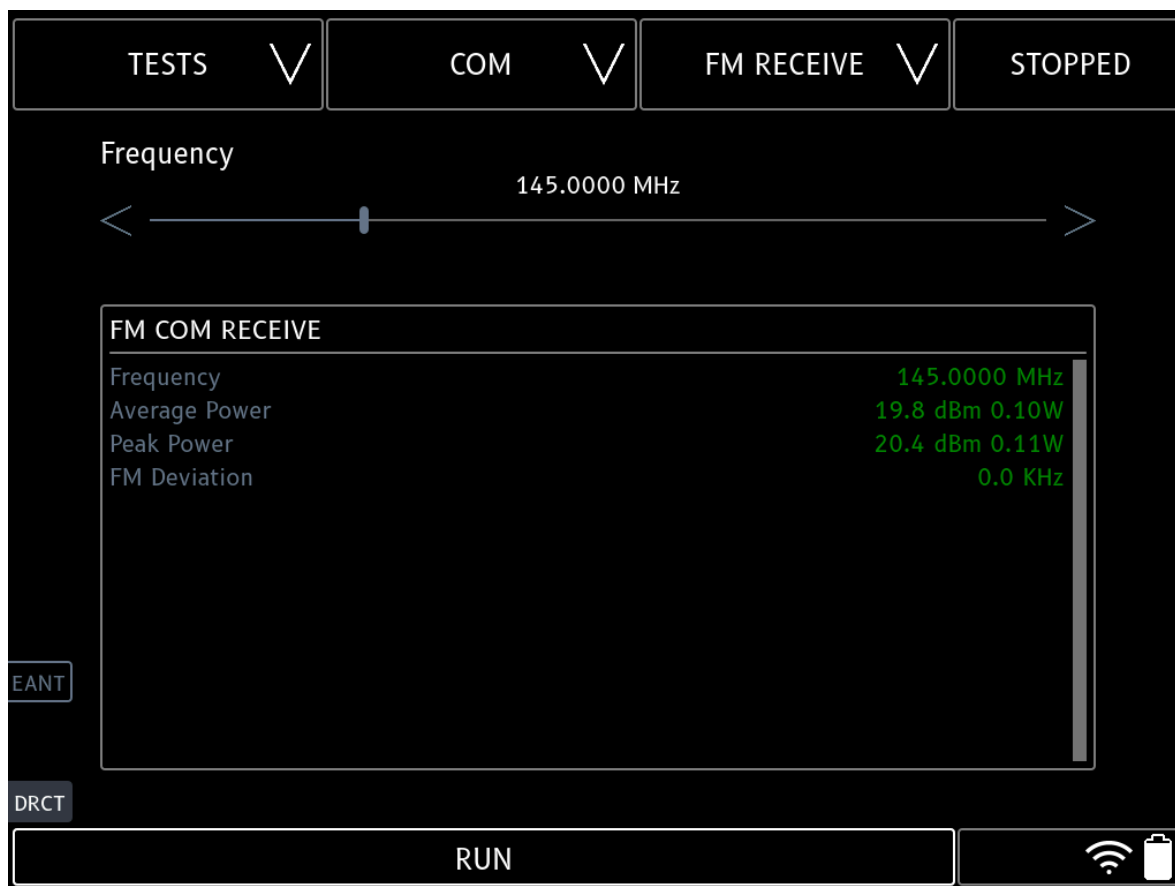

|                      |  |
|----------------------|--|
| Frequency (MHz)      | Select the desired frequency by using the slider, < > decrement/increment arrows, or selecting frequency/channel number and using keypad |
| EANT/DRCT            | Select EANT for the external antenna, DRCT for a direct connection, or no selection for the internal antenna                             |
| RUN/CANCEL           | Selecting RUN will receive the signal continuously until CANCEL is selected  |
| Frequency Result     | Measured frequency with a resolution of 100 Hz   |
| Average Power Result | Measured Average Power in dBm and Watts. Only displayed when Direct port is selected   |
| Peak Power Result    | Measured Peak Power in dBm and Watts. Only displayed when Direct port is selected  |
| RSSI Result          | A relative measure of received power when External or Internal port is selected  |
| FM Deviation Result  | Measured Modulation deviation in KHz. Only accurate with single tone modulation  |

## FM Receive Audio

A USB headset can be used to listen to transmitter modulation. Insert USB plug in T-RX™ USB receptacle before starting test.

## UHF Com Generate Test

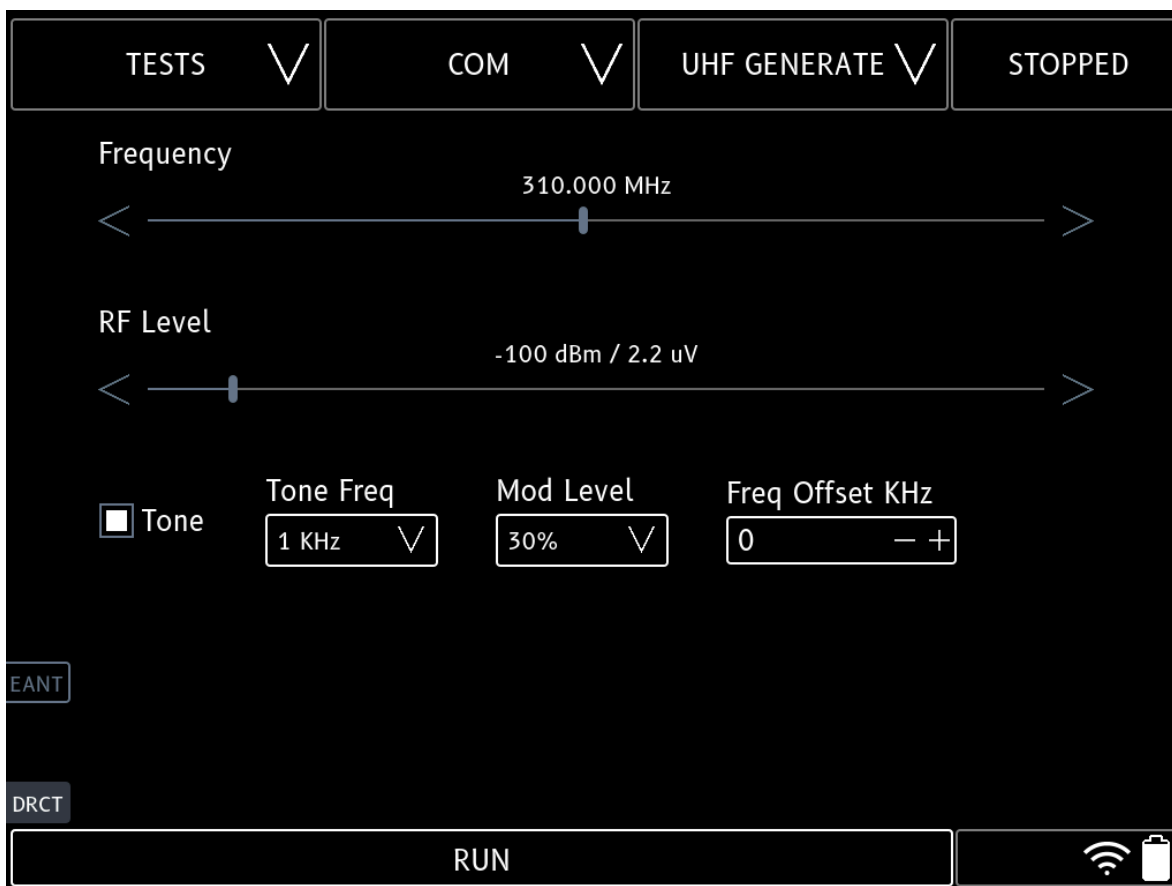

|                     |  |
|---------------------|--|
| Frequency (MHz)     | Select the desired frequency by using the slider, < > decrement/increment arrows, or selecting frequency/channel number and using keypad |
| RF Level (dBm / uV) | Set the RF level with the slider, < > decrement/increment arrows, or selecting level number and using keypad                             |
| Tone                | On or off  |
| Tone Freq           | Modulation tones from 300 Hz to 12 KHz. 8/12 KHz used for Carrier Squelch testing  |
| Mod Level           | 30% - 90%  |
| Freq Offset         | Generated frequency can be offset for selectivity testing  |
| EANT/DRCT           | Select EANT for the external antenna, DRCT for a direct connection, or no selection for the internal antenna                             |
| RUN/CANCEL          | Selecting RUN will output the signal continuously until CANCEL is selected   |

## UHF Com Receive Test

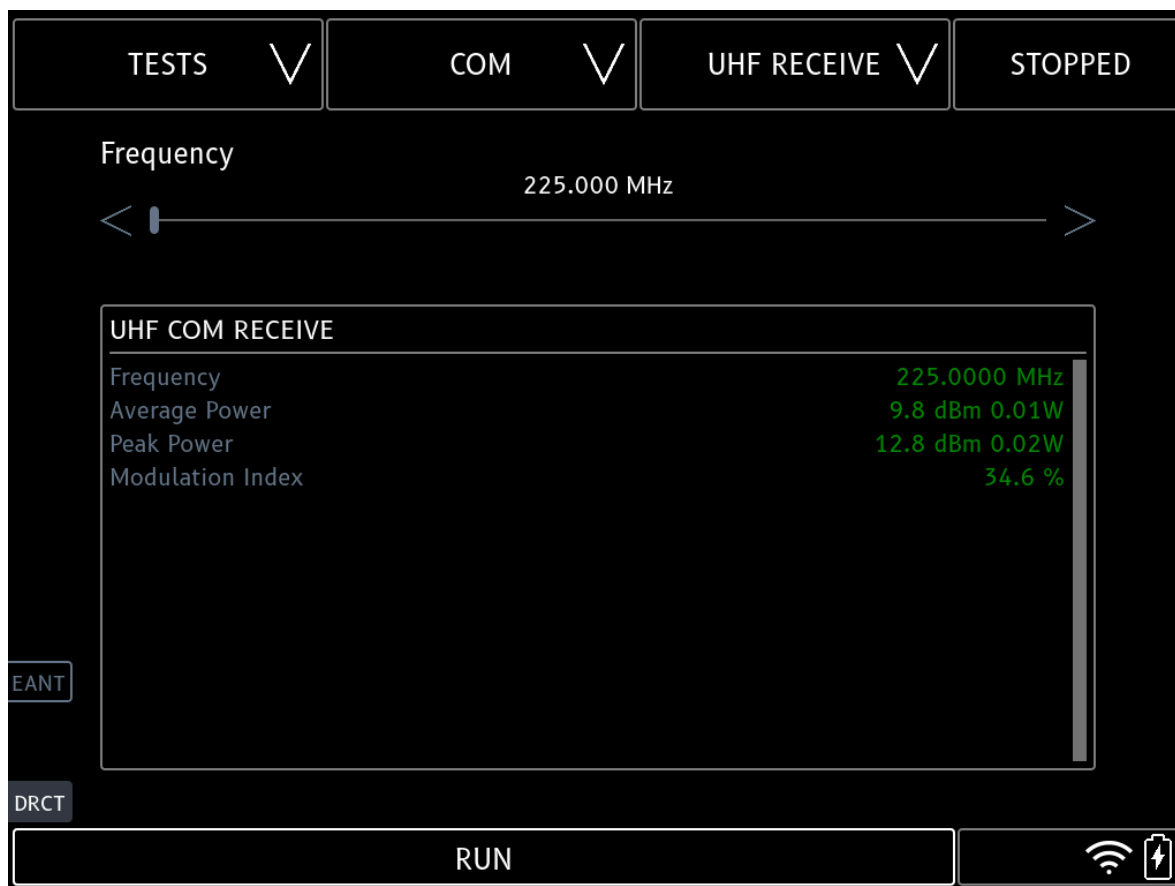

|                         |  |
|-------------------------|--|
| Frequency (MHz)         | Select the desired frequency by using the slider, < > decrement/increment arrows, or selecting frequency/channel number and using keypad |
| EANT/DRCT               | Select EANT for the external antenna, DRCT for a direct connection, or no selection for the internal antenna                             |
| RUN/CANCEL              | Selecting RUN will receive the signal continuously until CANCEL is selected  |
| Frequency Result        | Measured frequency with a resolution of 100 Hz   |
| Average Power Result    | Measured Average Power in dBm and Watts. Only displayed when Direct port is selected   |
| Peak Power Result       | Measured Peak Power in dBm and Watts. Only displayed when Direct port is selected  |
| RSSI Result             | A relative measure of received power when External or Internal port is selected  |
| Modulation Index Result | Measured Modulation percentage. Only accurate with single tone modulation  |

## UHF Receive Audio

A USB headset can be used to listen to transmitter modulation. Insert USB plug in T-RX™ USB receptacle before starting test.

## ELT 243 Testing

An ELT with 243 MHz output can be tested with the UHF Com Receive Test.

Test Setup:

Select 243 MHz.

Use Direct port

Use Peak Power for ELT power

Use USB headset for ELT modulation

## HF Com Generate Test



|                     |  |
|---------------------|--|
| 1020 Hz Tone        | On or off  |
| Frequency (MHz)     | Select the desired frequency by using the slider, < > decrement/increment arrows, or selecting frequency number and using keypad |
| RF Level (dBm / uV) | Set the RF level with the slider, < > decrement/increment arrows, or selecting level number and using keypad                     |
| Mode                | Upper Sideband (USB) or Amplitude Modulation (AM)  |
| EANT/DRCT           | Select EANT for the external antenna, DRCT for a direct connection, or no selection for the internal antenna                     |
| RUN/CANCEL          | Selecting RUN will output the signal continuously until CANCEL is selected   |

## HF Com Receive Test

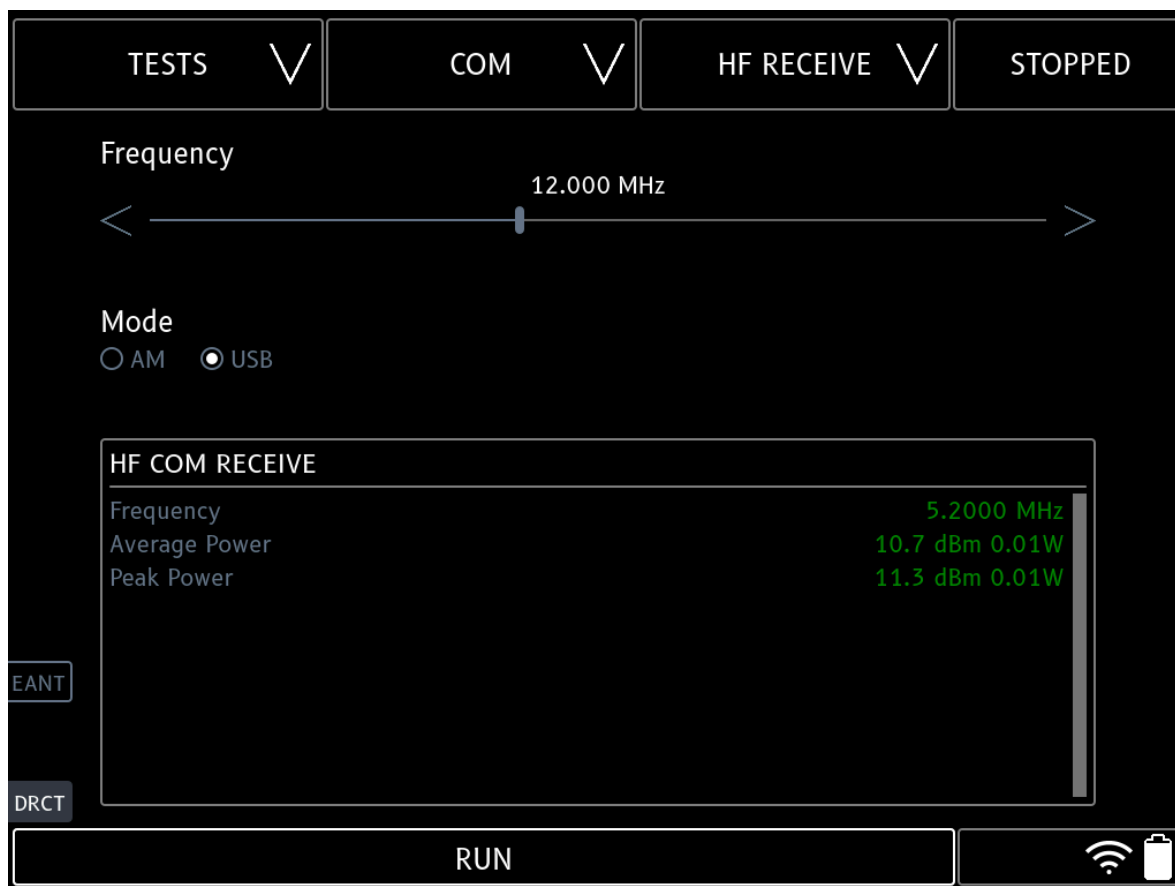

|                      |  |
|----------------------|--|
| Frequency (MHz)      | Select the desired frequency by using the slider, < > decrement/increment arrows, or selecting frequency number and using keypad |
| Mode                 | Upper Sideband (USB) or Amplitude Modulation (AM)  |
| EANT/DRCT            | Select EANT for the external antenna, DRCT for a direct connection, or no selection for the internal antenna                     |
| RUN/CANCEL           | Selecting RUN will receive the signal continuously until CANCEL is selected  |
| Frequency Result     | Measured frequency with a resolution of 100 Hz   |
| Average Power Result | Measured Average Power in dBm and Watts. Only displayed when Direct port is selected   |
| Peak Power Result    | Measured Peak Power in dBm and Watts. Only displayed when Direct port is selected  |
| RSSI Result          | A relative measure of received power when External or Internal port is selected  |

## HF Receive Audio

A USB headset can be used to listen to transmitter modulation. Insert USB plug in T-RX™ USB receptacle before starting test.

## SELCAL Test

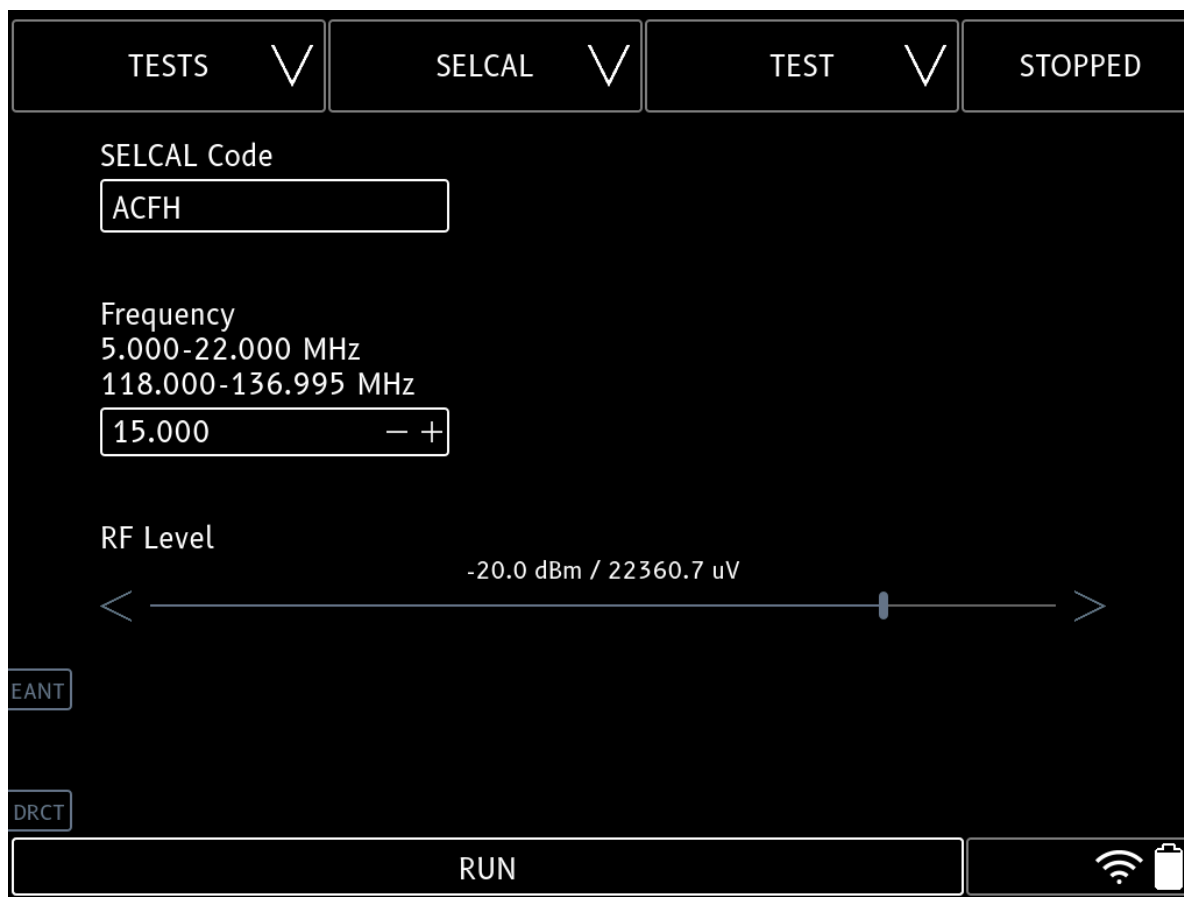

|                     |  |
|---------------------|--|
| SELCAL Code         | Enter a 16 or 32 Tone SELCAL Code  |
| Frequency (MHz)     | Enter the desired frequency  |
| RF Level (dBm / uV) | Set the RF level with the slider, < > decrement/increment arrows, or selecting level number and using keypad |
| EANT/DRCT           | Select EANT for the external antenna, DRCT for a direct connection, or no selection for the internal antenna |
| RUN/CANCEL          | Selecting RUN will output the SELCAL code sequence then stop   |

## ELT 406 Test

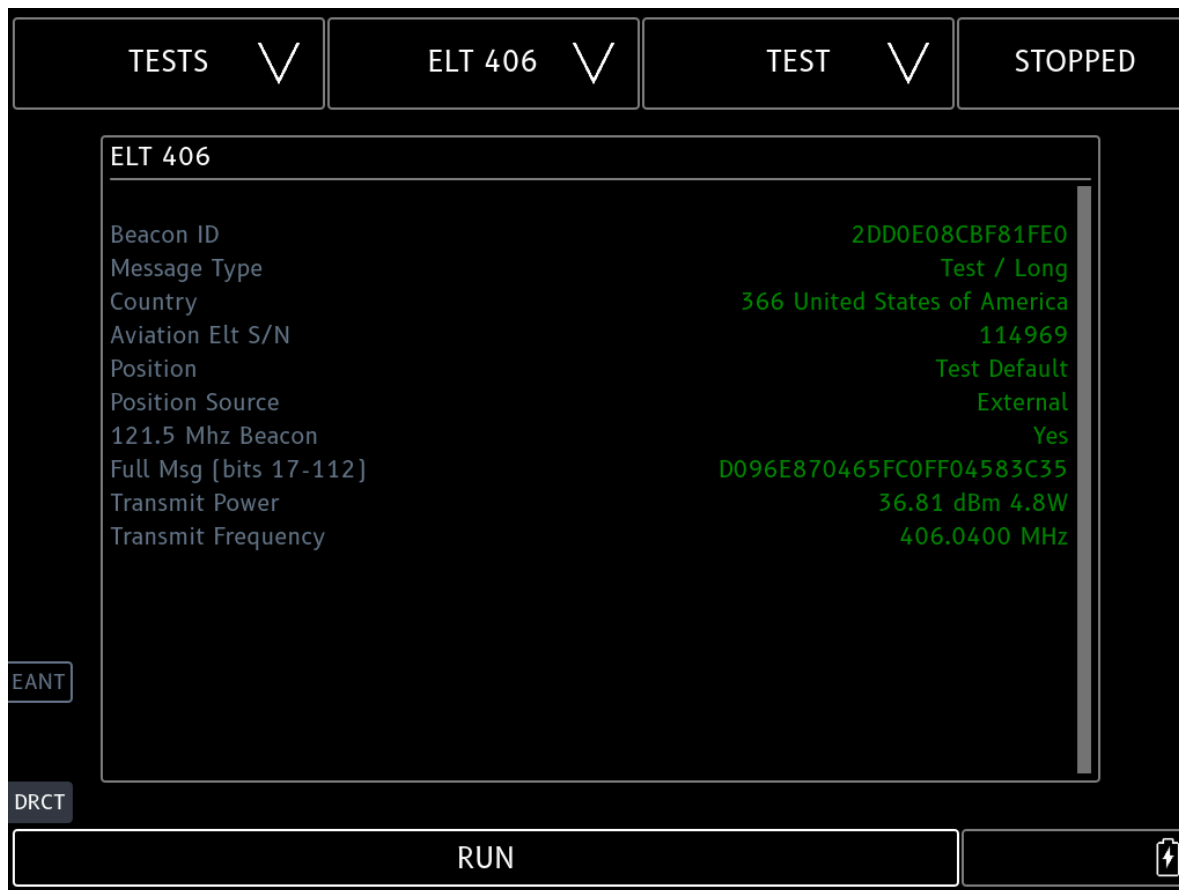

|   |  |
|---|--|
| EANT/DRCT   | Select EANT for an external antenna, DRCT for a direct connection, or no selection for the internal antenna  |
| RUN/CANCEL  | Selecting RUN will run the test until a 406 burst is decoded or CANCEL is selected. If Continuous Mode is enabled in Test Config the result will be displayed and test will continue running |
| Note: Transmit Power is displayed only for DRCT connection. |  |

**WARNING:** Over the Air testing should be limited to Self Test Mode only. Any non-Self Test mode should connect the ELT to the Direct Port (DRCT) of the T-RX™ using a low loss coax cable.

## ELT(DT) 406 Test

| Parameter                 | Value                          |
|---------------------------|--------------------------------|
| Beacon ID                 | 2DD25030ECBFDF                 |
| Message Type              | Normal / Long                  |
| Country                   | 366 United States of America   |
| ELT(DT) Location Protocol |                                |
| Aircraft ICAO Address     | A061D9 [50060731] USA N12345   |
| Means of Activation       | Automatic External             |
| Altitude Above Sea Level  | ≤1400m [1312ft]                |
| Position                  | S44° 59' 56" W74° 59' 56"      |
| Location Data Age         | >2 sec <60 sec                 |
| Full Msg [bits 25-144]    | 96E92818766B54B4278E2080201EBA |
| Transmit Power            | 36.81 dBm 4.8W                 |
| Transmit Frequency        | 406.0400 MHz                   |

ELT(DT) (Distress Tracking) mode is decoded automatically. Means of Activation, MSL Altitude, Cancellation, and Location Data Age is decoded.

If Continuous Mode is enabled, the test will continue to run and decode each burst.

**WARNING:** Over the Air testing should be limited to Self Test Mode only. Any non-Self Test mode should connect the ELT to the Direct Port (DRCT) of the T-RX™ using a low loss coax cable.

## ELT 406 Test Config



|                                  |  |
|----------------------------------|--|
| <p><b>External Loss (dB)</b></p> | <p>Applies to DRCT or EANT selections only. External loss refers to the loss of the coax connection when using the DRCT connection, or of the external antenna when using the EANT selection. Set the external loss by pressing &lt; or &gt;, or manually sliding to the required external loss level. See External Antenna section for more information</p>                     |
| <p><b>Distance (ft)</b></p>      | <p>Applies to EANT or internal antenna selections only. Distance refers to the distance in feet from the antenna under test to the T-RX™ when using the EANT or internal antenna selections. Set the distance by pressing &lt; or &gt;, or manually sliding to the required distance</p> <p>NOTE: Over-the-air ELT reception is most reliable at distances of 10 ft or more.</p> |
| <p><b>Continuous Mode</b></p>    | <p>Select to continue running the test after a beacon burst is decoded. Primarily for ELT(DT) testing</p>  |

## DME Test

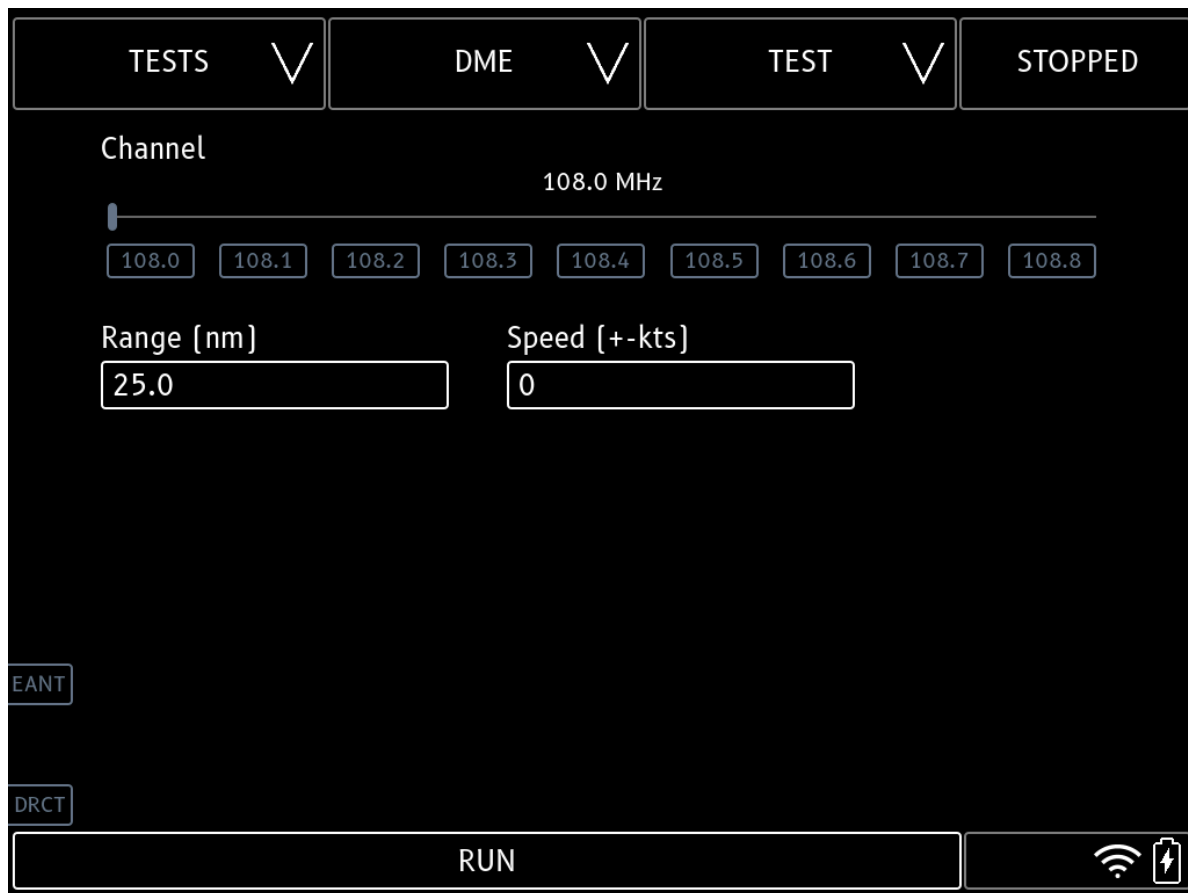

|           |   |
|-----------|---|
| EANT/DRCT | Select EANT for an external antenna, DRCT for a direct connection, or no selection for the internal antenna |
| Channel   | Paired VOR/ILS frequency of DME   |
| Range     | Initial distance from DME ground station  |
| Speed     | Velocity to/from DME ground station   |

## DME Test Config



|                                  |  |
|----------------------------------|--|
| <p><b>External Loss (dB)</b></p> | <p>Applies to DRCT or EANT selections only. External loss refers to the loss of the coax connection and optional coupler to a DME when using the DRCT connection, or of the external antenna when using the EANT selection. Set the external loss by pressing &lt; or &gt;, or manually sliding to the required external loss level. See External Antenna section for more information</p> |
| <p><b>Distance (ft)</b></p>      | <p>Applies to EANT or internal antenna selections only. Distance refers to the distance in feet from the DME antenna under test to the T-RX™ when using the EANT or internal antenna selections. Set the distance by pressing &lt; or &gt;, or manually sliding to the required distance</p>   |

## TCAS Test

TESTS ▾
TCAS ▾
TEST ▾
STOPPED

Target Distance [nm]

Target Speed [kts]

Target Altitude [ft]

Target Vert Rate [+ft/min]

EANT

DRCT

RUN

|                  |   |
|------------------|---|
| EANT/DRCT        | Select EANT for an external antenna, DRCT for a direct connection, or no selection for the internal antenna |
| Target Distance  | Distance of TCAS target   |
| Target Speed     | Velocity of TCAS target (negative velocity will move target toward aircraft)                                |
| Target Altitude  | Pressure altitude of TCAS target  |
| Target Vert Rate | Vertical Rate of TCAS target  |

### TCAS Test Config



|                                  |   |
|----------------------------------|---|
| <p><b>External Loss (dB)</b></p> | <p>Applies to DRCT or EANT selections only. External loss refers to the loss of the coax connection and optional coupler to a TCAS when using the DRCT connection, or of the external antenna when using the EANT selection. Set the external loss by pressing &lt; or &gt;, or manually sliding to the required external loss level. See External Antenna section for more information</p> |
| <p><b>Distance (ft)</b></p>      | <p>Applies to EANT or internal antenna selections only. Distance refers to the distance in feet from the TCAS antenna under test to the T-RX™ when using the EANT or internal antenna selections. Set the distance by pressing &lt; or &gt;, or manually sliding to the required distance</p>   |

## Transponder Mode A/C/S Test

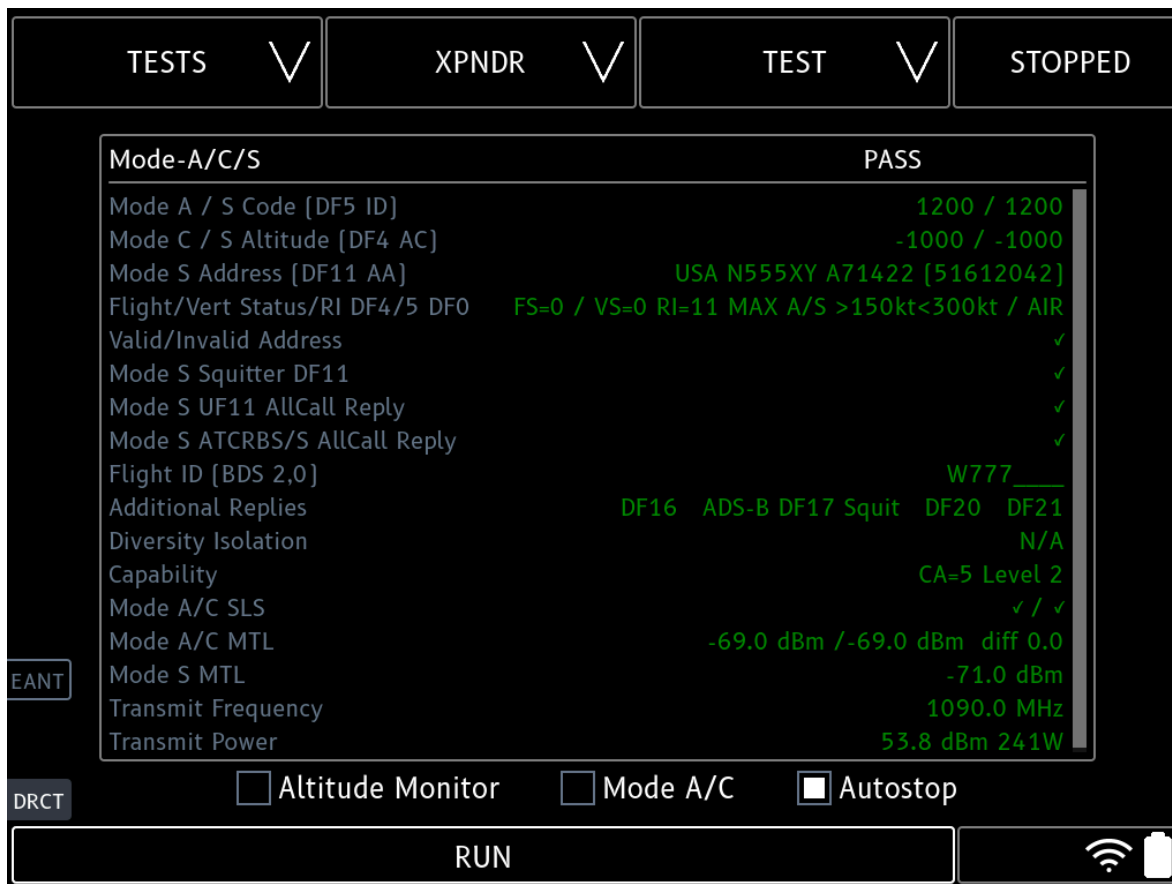

|                  |  |
|------------------|--|
| EANT/DRCT        | EANT for an external antenna, DRCT for a direct connection, no selection for internal antenna  |
| RUN/CANCEL       | Selecting RUN will run the test continuously until CANCEL is selected. MODE-S will be automatically detected   |
| Altitude Monitor | Altitude Monitor selected will only display altitude during a test for a higher update rate. Intended for Altitude Correspondence testing. Also shows Mode C altitude Gray code bits |
| Mode A/C         | Select for Mode A/C transponder. Mode-S modes will not be interrogated   |
| Autostop         | Select to stop the test once all parameters are valid  |
| PASS/FAIL        | Indication of overall test status  |

**NOTE: A Transponder antenna coupler should only be attached to the DIRECT antenna port**

**NOTE: Simultaneous use of GPS Generator Test and XPNDR Test is not recommended due to T-RX™ resources required by both tests.**

## Transponder Test Config

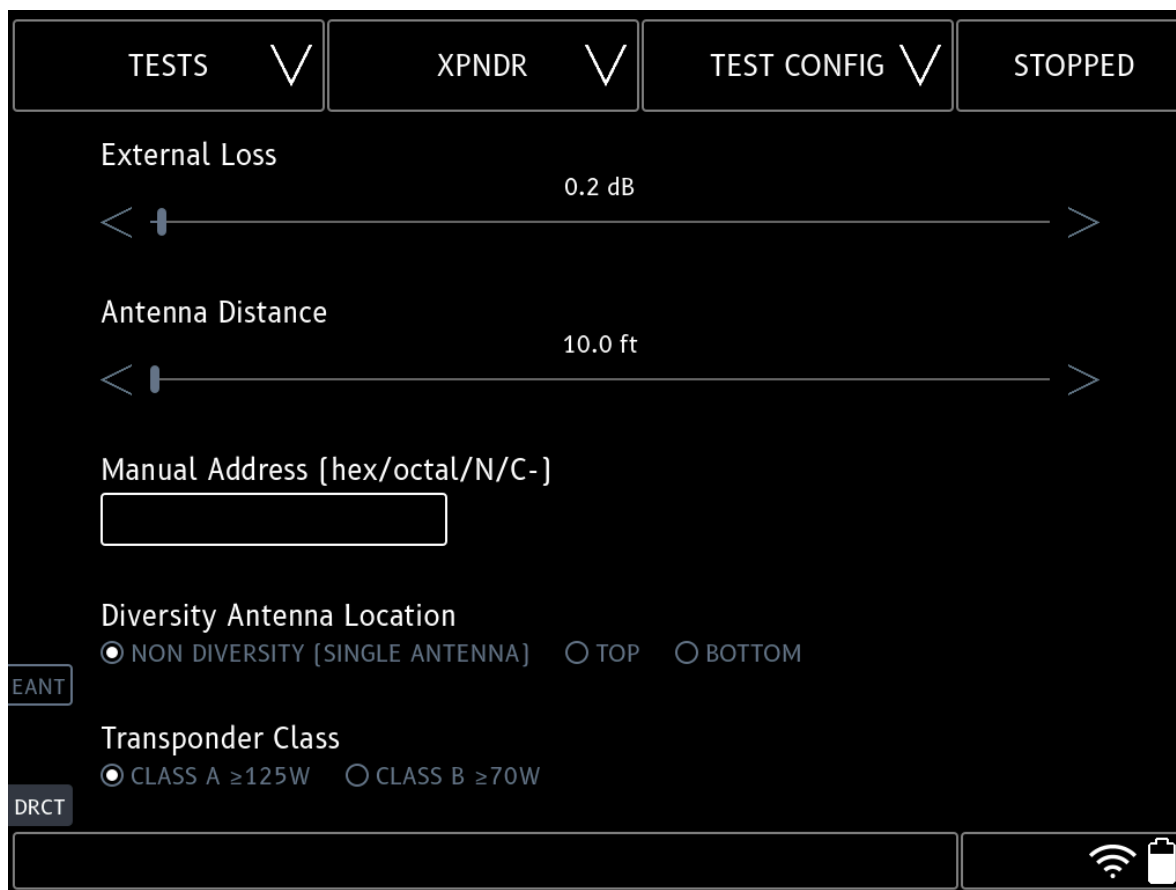

|                            |   |
|----------------------------|---|
| External Loss (dB)         | Applies to DRCT or EANT selections only. External loss refers to the loss of the coax connection and optional coupler to a transponder when using the DRCT connection, or of the external antenna when using the EANT selection. Set the external loss by pressing < or >, or manually sliding to the required external loss level. See External Antenna section for more information |
| Distance (ft)              | Applies to EANT or internal antenna selections only. Distance refers to the distance in feet from the transponder antenna under test to the T-RX™ when using the EANT or internal antenna selections. Set the distance by pressing < or >, or manually sliding to the required distance   |
| Manual Address             | Restrict Mode-S replies to a Hex address, Octal address, or USA/Canada tail number. Useful when over-the-air tests are performed when multiple powered on aircraft are in the direct vicinity   |
| Diversity Antenna Location | Select from NON-DIVERSITY (Single Antenna), TOP, or BOTTOM  |
| Transponder Class          | Controls minimum power for successful test  |

## Transponder Mode A/C/S Test Item Descriptions

|                                      |   |
|--------------------------------------|---|
| <b>Mode A/S Code</b>                 | Mode A ATCRBS / Mode S DF5 Squawk code. IDENT and ALERT if active. Appendix F(g) for Mode S   |
| <b>Mode C/S Altitude</b>             | Mode C altitude (100 ft resolution) / Mode S DF4 altitude (100 or 25 ft resolution). Appendix F(g) for Mode S   |
| <b>Mode S Address</b>                | Mode S DF11 AA ICAO address with Country / registration decoding (decoding USA and Canada only) / Hex / Octal   |
| <b>Flight/Vert Status</b>            | FS value / VS value / RI value with RI Max Airspeed decoding / Mode S AIR or GND state  |
| <b>Valid/Invalid Address</b>         | ✓ If Mode S transponder only replies to its assigned address, otherwise X. Appendix F(f)  |
| <b>Mode S Squitter DF11</b>          | ✓ If Mode S DF11 correct squitter is present approximately once per second, otherwise X. Appendix F(j)  |
| <b>Mode S UF11 AllCall Reply</b>     | ✓ If Mode S replies to Mode S only UF11 All Call, otherwise X. Appendix F(h)  |
| <b>Mode S ATCRBS/S AllCall Reply</b> | ✓ If Mode S replies to ATCRBS/Mode S All Call, otherwise X. Appendix F(h)   |
| <b>Flight ID</b>                     | Mode S Flight ID (BDS 2,0)  |
| <b>Additional Replies</b>            | Presence of ADS-B DF17 squitter, and DF16 DF24, DF20, DF21 Mode S replies if capable. Appendix F(g)   |
| <b>Diversity Isolation</b>           | ✓ If Mode S Diversity Isolation is $\geq 20$ dB, otherwise X. Only applicable to a Mode S Diversity transponder and also requires the non-tested antenna to be shielded. The test should be performed on the top and bottom antenna separately. Appendix F(e) |
| <b>Transmit Frequency</b>            | Green if the transponder transmit frequency is $1090 \pm 1$ for Mode-S replies, $\pm 3$ MHz for ATCRBS only replies, otherwise red (note 1). Appendix F(a)  |
| <b>Mode A/C SLS</b>                  | ✓ If Mode A transponder replies are $\leq 1\%$ when P2 pulse is equal to P1 Pulse, and replies are $\geq 90\%$ when P2 pulse is 9 dB less than P1 pulse, otherwise X. Appendix F(b)   |
| <b>Mode A/C MTL</b>                  | MTL of Modes A and C and difference between MTLs. Green if MTL is -66dBm to -80dBm and MTL difference between Mode A and C receiver is not greater than 1dB, otherwise red. Appendix F(c) with an additional 3dB allowance for portable test equipment        |

|                       |  |
|-----------------------|--|
| <b>Mode S MTL</b>     | MTL of Mode S transponder. <b>Green</b> if MTL is -67dBm to -81dBm, otherwise <b>red</b> . Appendix F(c) with an additional 3dB allowance for portable test equipment  |
| <b>Transmit Power</b> | Transmit Peak Power in dBm and Watts. <b>Green</b> if power is $\geq 51$ dBm (21 dBW, 125 W) or $\geq 48.5$ dBm (18.5 dBW, 70W) and $\leq 57$ dBm (27 dBW, 500 W) (note 2). Appendix F(d)  |
| <b>Note 1</b>         | Class 1A/2A/3A/4 Mode S transponders have an Appendix F limit of $\pm 1$ MHz. Class 1B/2B/3B/4 Mode S transponders have an optional Appendix F(a) limit of $\pm 1$ MHz. All ATCRBS only transponders have an Appendix F limit of $\pm 3$ MHz |
| <b>Note 2</b>         | Select Class A or B in TEST CONFIG menu. Class A transponders have a minimum power of 51 dBm (21 dBW, 125W) , Class B transponders have a minimum power of 48.5 dBm (18.5 dBW, 70 W) in Appendix F(d)  |

## Altitude Monitor Test

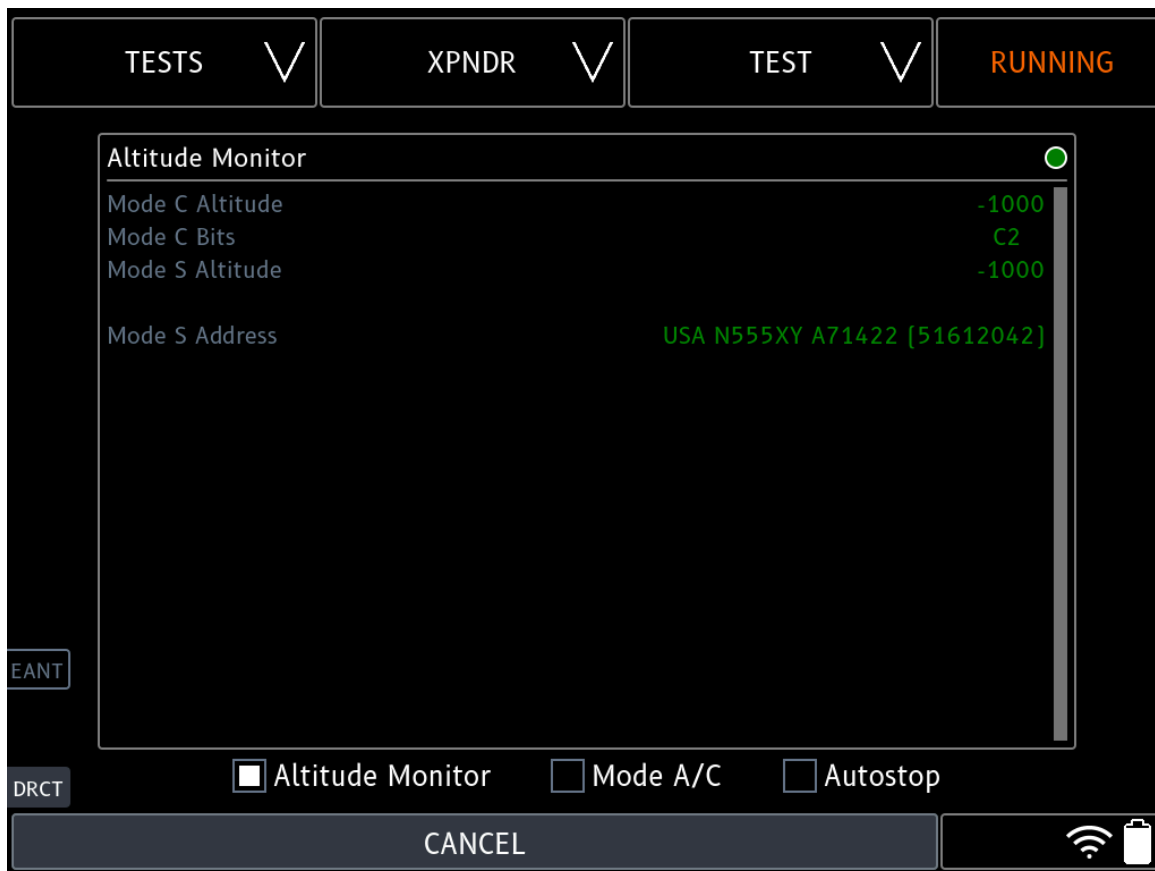

**NOTE:** Altitude Monitor will only display altitude during a test for a higher update rate. Intended for Altitude Correspondence testing. To enable select the Altitude Monitor box on the XPNDR Test Config page. Deselect Autostop.

## ADS-B OUT 1090ES Test

Airborne Mode

TESTS ▾
ADS-B OUT 1090 ▾
TEST ▾
RUNNING

|                                      |  |
|--------------------------------------|--|
| <b>1090ES DF17</b>                   | <b>PASS</b> <span style="color: green;">●</span> |
| Mode S Address                       | USA N555XY A71422 [51612042]                     |
| Flight ID [BDS 0,8 Type 4]           | W777___  |
| Latitude/Longitude [BDS 0,5 Type 11] | 40° 38.948' / -74° 37.969'                       |
| Pressure Altitude                    | 2000 ft  |
| Geometric Altitude                   | 200 ft   |
| Groundspeed [BDS 0,9 Type 19]        | W 0 / S 0 kts                                    |
| Mode A Code                          | 1200   |
| Emergency/Priority Status / State    | No Emergency [0] / Airborne                      |
| Emitter Category                     | Light < 15.5K lbs [A1]                           |
| TCASII/ACAS Equipped/Operational     | No [0]   |
| ADS-B IN                             | 1090ES   |
| NACp                                 | < 10m [10] ✓                                     |
| NACv                                 | < 3 m/s [2] ✓                                    |
| NIC                                  | 9 ✓  |
| SDA                                  | DAL C [2] ✓                                      |
| SIL/SIL SUP                          | ≤1x10 <sup>-7</sup> [3]/hour [0] ✓               |
| MOPS Version [BDS 6,5 Type 31]       | v2 DO-260B/ED-102A DO-242B ✓                     |

EANT
DRCT
 Autostop

CANCEL

|                                     |                         |
|-------------------------------------|-------------------------|
| TIME                                | Synchronized UTC No [0] |
| GVA                                 | ≤45m [2]                |
| Vertical Rate                       | +0 ft/min               |
| Baro Setting [BDS 6,2 Type 29]      | 29.93 inHg              |
| Selected Altitude [BDS 6,2 Type 29] | 2496 ft Src: MCP/FCU    |
| Selected Heading [BDS 6,2 Type 29]  | 30.2°                   |
| MCP/FCU Modes                       | ---                     |
| Antenna                             | Single                  |

Autostop

CANCEL

### Surface Mode

|            |   |
|------------|---|
| EANT/DRCT  | EANT for an external antenna, DRCT for a direct connection, no selection for internal antenna |
| RUN/CANCEL | Selecting RUN will run the test continuously until CANCEL is selected.                        |
| PASS/FAIL  | Indication of overall test status   |

**NOTE: A Transponder antenna coupler should only be attached to the DIRECT antenna port**

### ADS-B OUT 1090 Test Config

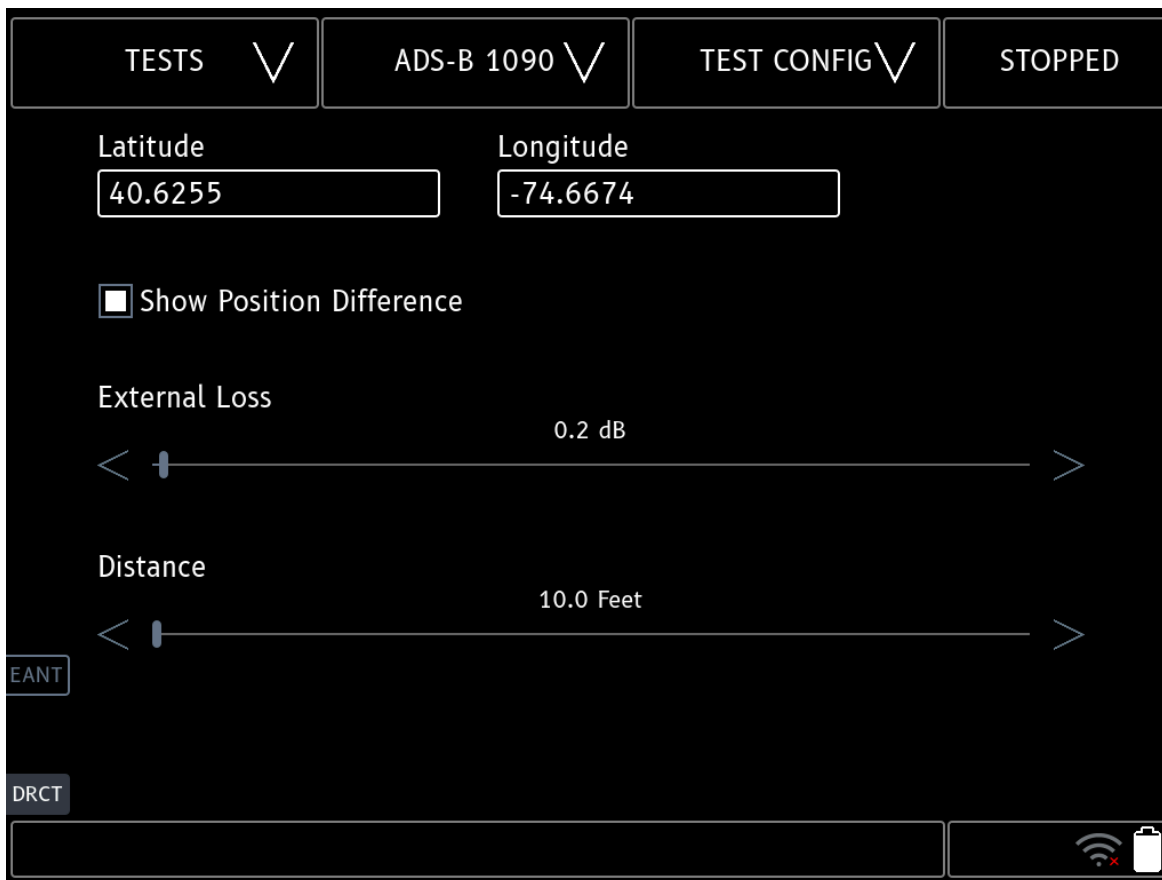

|                                 |  |
|---------------------------------|--|
| <b>Latitude</b>                 | The latitude where the test is being performed, in whole degrees (Positive latitude is N, negative is S). Latitude does not need to be exact (unless Show Position Difference is selected), it indicates the N or S hemisphere for surface position ambiguity resolution. If the configured Latitude is in the correct hemisphere then the surface position will be decoded correctly                                |
| <b>Longitude</b>                | The longitude where the test is being performed, in whole degrees (Positive longitude is E, negative is W). Longitude does not need to be exact (unless Show Position Difference is selected), it indicates the E/W quadrants (< 90 E, ≥ 90 E, < 90 W, ≥ 90 W) for Surface Position ambiguity resolution. If the configured Longitude is in the correct quadrant then the surface position will be decoded correctly |
| <b>Show Position Difference</b> | If selected, the Position Difference field will be shown in the test page. Use exact decimal degrees for latitude and longitude fields   |
| <b>External Loss (dB)</b>       | Applies to DRCT or EANT selections only. External loss refers to the loss of the coax connection and optional coupler to a transponder when using the DRCT connection, or of the external antenna and coax when using the EANT selection. Set the external loss by pressing < or >, or manually sliding to the required external loss level  |

|                      |   |
|----------------------|---|
| <b>Distance (ft)</b> | Applies to EANT or internal antenna selections only. Distance refers to the distance in feet from the transponder antenna under test to the T-RX™ when using the EANT or internal antenna selections. Set the distance by pressing < or >, or manually sliding to the required distance |
|----------------------|---|

## ADS-B 978 UAT Test

The screenshot displays the following test results:

| Parameter                      | Value                           |
|--------------------------------|---------------------------------|
| Mode S Address                 | CFGLL C01102 [60010402]         |
| Flight ID                      | CFGLL__                         |
| Length/Width Upper Bound [Gnd] | 15m/23m                         |
| Latitude/Longitude             | 40° 37.529' / -74° 40.098'      |
| Pressure Altitude              | 550 ft                          |
| Geometric Altitude             | 0 ft                            |
| Direction/Groundspeed          | 289.7° Trk T / 9 kts            |
| Mode A Status/Code             | 1200                            |
| State                          | Surface                         |
| Emitter Category               | Light < 15.5K lbs [1]           |
| TCAS / ADS-B IN                | UAT 1090ES                      |
| NACp                           | < 30m [9] ✓                     |
| NACv                           | <10 m/s [1] ✓                   |
| NIC                            | 8 ✓                             |
| SDA                            | DAL C [2] ✓                     |
| SIL                            | ≤1x10 <sup>-7</sup> /hour [3] ✓ |
| MOPS Version                   | v2 DO-282B ✓                    |
| Transmit Power/Frequency       | 43.8 dBm 24W / 977.2 MHz        |

|   |  |
|---|--|
| EANT/DRCT   | Select EANT for an external antenna, DRCT for a direct connection, or no selection for the internal antenna  |
| RUN/CANCEL  | Selecting RUN will run the test continuously until CANCEL is selected. MODE-S will be automatically detected |
| <b>NOTE: A Transponder antenna coupler should only be attached to the DIRECT antenna port</b> |  |

### ADS-B 978 Test Config



|                                  |  |
|----------------------------------|--|
| <p><b>External Loss (dB)</b></p> | <p>Applies to DRCT or EANT selections only. External loss refers to the loss of the coax connection and optional coupler to a transponder when using the DRCT connection, or of the external antenna and coax when using the EANT selection. Set the external loss by pressing &lt; or &gt;, or manually sliding to the required external loss level</p> |
| <p><b>Distance (ft)</b></p>      | <p>Applies to EANT or internal antenna selections only. Distance refers to the distance in feet from the transponder antenna under test to the T-RX™ when using the EANT or internal antenna selections. Set the distance by pressing &lt; or &gt;, or manually sliding to the required distance</p>   |

## ADS-B 1090ES / ADS-B 978 UAT Test Item Descriptions

AC 20-165B required elements shown as error if missing or below requirements

|   |   |
|---|---|
| <b>Mode S Address</b>                             | DF17 ICAO address with country and registration decoding (decoding USA and Canada only) / Hex / Octal   |
| <b>Flight ID</b>                                  | DF17 Flight ID. Error if missing  |
| <b>Length / Width Upper Bound (Gnd)</b>           | Reported when in the ground state with raw value. Error if undefined  |
| <b>Latitude / Longitude</b>                       | Positive latitude is N, negative is S. Positive longitude is E, negative is W. 1090ES Surface (Gnd) position requires current position set in the config page to resolve N-S hemisphere and E-W quadrant ambiguity<br><br>Note: 1090ES position is decoded using the Global CPR algorithm which fully utilizes all even/odd data sent in the ADS-B messages |
| <b>Pressure / GNSS Altitude</b>                   | Type is Pressure or GNSS (HAE) as reported by ADS-B transmitter, or "—" if unavailable. Only reported in Air mode   |
| <b>Geometric Altitude</b>                         | Reported if altitude type is pressure and GNSS altitude available. Only reported in Air mode  |
| <b>Groundspeed</b><br><br>-or-<br><b>Airspeed</b> | E/W and N/S if GNSS velocity over ground available<br><br>Airspeed in knots if groundspeed is not available   |
| <b>Heading / Track</b>                            | Heading/Track Mag/True if groundspeed is not available  |
| <b>Mode A Code</b>                                | Mode A squawk. IDENT, Emerg Alert, Temp Alert if active. Allowed to be missing if Mode A code is set to 1000  |
| <b>Emergency / Priority Status</b>                | Emergency/Priority Status type and code   |
| <b>State</b>                                      | Airborne or Surface   |
| <b>Emitter Category</b>                           | Category and raw value as programmed in the ADS-B transmitter. Error if missing   |

|  |  |
|--|--|
| <b>TCAS II /<br/>ACAS<br/>Equipped /<br/>Operational</b> | TCAS II or ACAS equipment installed and operational and raw value. It will also report if an RA is in progress |
| <b>ADS-B IN</b>  | UAT and/or 1090ES IN capability reported   |
| <b>NACp</b>  | Navigation Accuracy Category - Position<br>Error if below 8  |
| <b>NACv</b>  | Navigation Accuracy Category - Velocity<br>Error if 0  |
| <b>NIC</b>   | Navigation Integrity Category<br>Error if below 7  |
| <b>SDA</b>   | System Design Assurance<br>Error if below 2  |
| <b>SIL/SIL SUP</b>                                       | Source Integrity Level and Supplement with raw values<br>SIL Error if below 3                                  |
| <b>MOPS Version</b>                                      | MOPS Version number and corresponding RTCA / EUROCAE standards<br>Error if below 2                             |
| <b>TIME</b>  | ADS-B transmissions synchronized to UTC and raw value  |
| <b>NICbaro</b>   | Indicates pressure altitude crosscheck status and raw value  |
| <b>Vertical Rate</b>                                     | Vertical Rate in ft/min  |
| <b>GVA</b>   | Geometric Vertical Accuracy and raw value  |
| <b>Baro Setting</b>                                      | Optional baro pressure setting   |
| <b>Selected<br/>Altitude</b>                             | Optional selected altitude   |
| <b>Selected<br/>Heading</b>                              | Optional selected heading  |
| <b>MCP/FCU<br/>Modes</b>                                 | Optional Mode Control Panel/Flight Control Unit/FMS modes  |
| <b>Antenna</b>   | Single or Dual   |

## ADS-B IN 1090 Test

TESTS ▾
ADS-B IN 1090 ▾
TEST ▾
STOPPED

Target Distance [nm]

Target Altitude [ft]

Target Bearing [deg]

Target Speed [kts]

Target Vert Rate [+/-ft/min]

Ownship Address [hex/octal]

Target Type  
 AIR    GROUND

EANT
DRCT

RUN

|                 |  |
|-----------------|--|
| Target Distance | Initial distance of target from position set in Config page. If Speed is set, target distance will decrease                              |
| Target Speed    | Speed encoded in target ADS-B transmission   |
| Target Altitude | Initial altitude of target. If Vert Rate is set, target altitude will increase or decrease   |
| Target Bearing  | True Bearing of target from position set in Config page  |
| Ownship Address | ICAO Address of the aircraft being tested, in Hex or Octal. This sets the Service Address for TIS-B and ADS-R service (the "Tower" icon) |
| Target Type     | Airborne or Surface target type  |

### ADS-B IN 1090 Test Config

TESTS ▾
ADS-B IN 1090 ▾
TEST CONFIG ▾
STOPPED

Latitude Degrees

Longitude Degrees

Target Address [hex/octal]

Latitude Minutes

Longitude Minutes

External Loss

0.5 dB

< ————— >

Distance

10.0 Feet

< ————— >

Target Type

LIGHT  
  HEAVY  
  SURF VEHICLE

Mode

ADS-B  
  TIS-B  
  ADS-R

DRCT
EANT

|                    |   |
|--------------------|---|
| Latitude/Longitude | Lat/Lon in decimal degrees or whole degrees and decimal minutes.<br>Example: 40.5 degrees and 0 minutes is equivalent to 40 degrees and 30 minutes  |
| Target Address     | ICAO Address of target  |
| External Loss (dB) | Applies to DRCT or EANT selections only. External loss refers to the loss of the coax connection and optional coupler to a transponder when using the DRCT connection, or of the external antenna and coax when using the EANT selection. Set the external loss by pressing < or >, or manually sliding to the required external loss level |
| Distance (ft)      | Applies to EANT or internal antenna selections only. Distance refers to the distance in feet from the transponder antenna under test to the T-RX™ when using the EANT or internal antenna selections. Set the distance by pressing < or >, or manually sliding to the required distance   |
| Target Type        | Class of target   |
| Mode               | ADS-B, TIS-B, or ADS-R Target Type  |

## MODE-S GICB Test

TESTS ▾
MODE-S GICB ▾
TEST ▾
RUNNING

**ELS/EHS Registers** ●

Mode S Address N1234 A061BB [50060673] Level ≥ 2 Datalink Capable

Register 10h Datalink Capability Report [ELS Required]

Continuation Flag: N Overlay: Y Level 5: N Specific Services: Y  
 TCAS [ELS Required if installed]: N Flight ID [ELS Required]: Y  
 Squitter: Y Surv ID: Y GICB Changed: Y UELM: None DELM: None  
 Subnetwork Version: [5] DO-181E / ED-73E Subnetwork Addr: 00

Register 17h Common GICB Capability Reports Available [ELS Required] ✓

Register 05h Extended Squitter Airborne Position ✓

Register 06h Extended Squitter Surface Position ✓

Register 07h Extended Squitter Status ✓

Register 08h Extended Squitter Identification and Category ✓

Register 09h Extended Squitter Airborne Velocity Information ✓

Register 0Ah Extended Squitter Event-Driven Information ✓

Register 20h Aircraft identification [ELS Required] ✓

Register 21h Aircraft registration number ✓

Register 40h Selected vertical intention [EHS Required] ✓

Register 50h Track and turn report [EHS Required] ✓

Register 60h Heading and speed report [EHS Required] ✓

EANT
DRCT
CANCEL

Register 60h Heading and speed report [EHS Required] ✓

Register 20h Aircraft Identification/Flight ID [ELS Required] DCM123\_\_

Register 40h Selected Vertical Intention [EHS Required]

MCP/FCU Selected Altitude 22000 ft

Baro Setting 1013.2 mb 29.92 in/Hg

Register 50h Track and Turn Report [EHS Required]

Roll Angle 0.5° R

True Track Angle -89.6°

Ground Speed 176.0 kts

True Air Speed 156.0 kts

Register 60h Heading and Speed Report [EHS Required]

Magnetic Heading 207.1°

Indicated Air Speed 150.0 kts

EANT
DRCT
CANCEL

|   |   |
|---|---|
| EANT/DRCT   | Select EANT for an external antenna, DRCT for a direct connection, or no selection for the internal antenna |
| RUN/CANCEL  | Selecting RUN will run the test continuously until CANCEL is selected.                                      |
| <b>NOTE: A Transponder antenna coupler should only be attached to the DIRECT antenna port</b> |   |

### MODE-S GICB Test Config

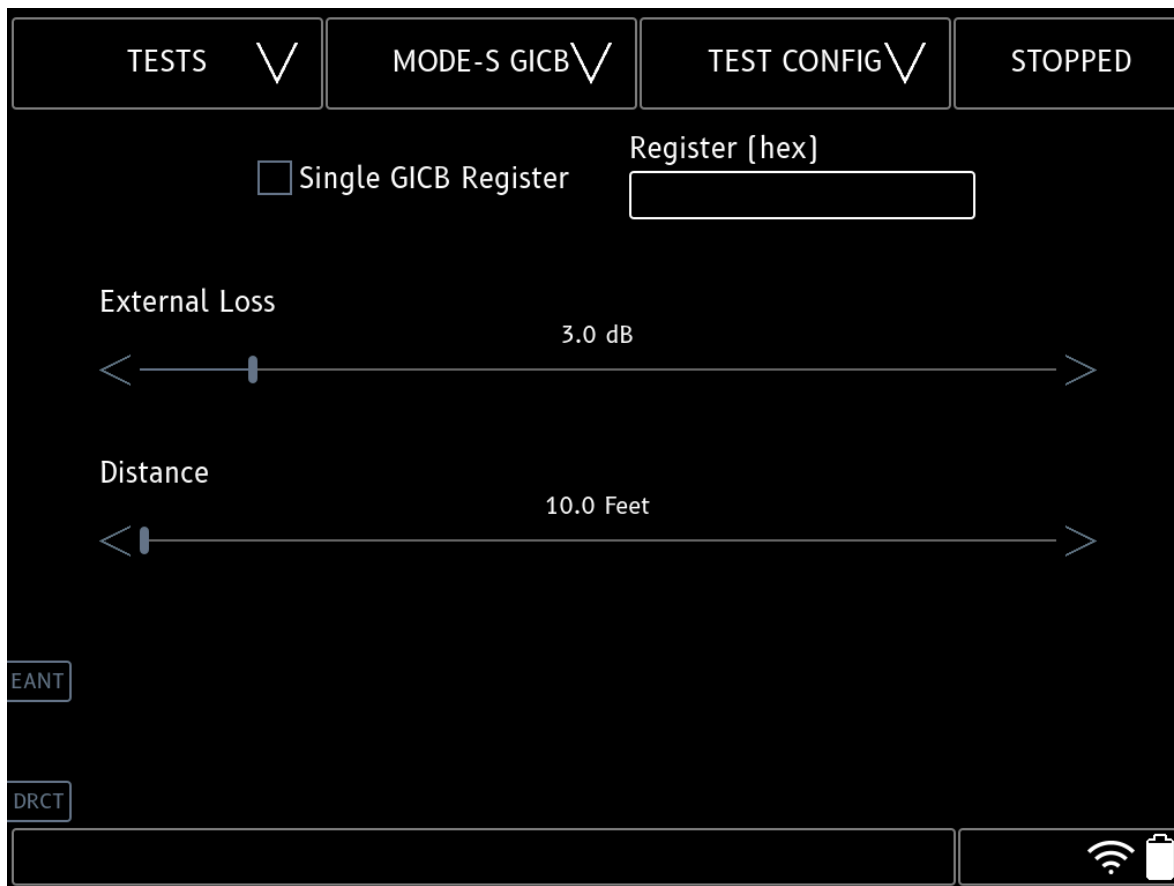

|                      |   |
|----------------------|---|
| Single GICB Register | Select to interrogate any single GICB Register  |
| Register             | Enter Hex value of single register to display. If not selected, all standard ELS/EHS registers displayed.   |
| External Loss (dB)   | Applies to DRCT or EANT selections only. External loss refers to the loss of the coax connection and optional coupler to a transponder when using the DRCT connection, or of the external antenna and coax when using the EANT selection. Set the external loss by pressing < or >, or manually sliding to the required external loss level |
| Distance (ft)        | Applies to EANT or internal antenna selections only. Distance refers to the distance in feet from the transponder antenna under test to the T-RX™ when using the EANT or internal antenna selections. Set the distance by pressing < or >, or manually sliding to the required distance   |

## ANTENNA/COAX Test

Antennas, Coax, and Antenna Systems can be analyzed for Distance-to-Fault, VSWR, Return Loss, and Cable Loss.

VSWR measurements can optionally be compensated for expected coax loss, given coax type and expected length.

Cable Loss measurements will show expected loss in the selected frequency band given coax type and expected length.

Note: Active antennas such as GPS and XM/SXM cannot be tested. Nav measurements performed through a VOR/LOC splitter and/or Glideslope splitter will not be accurate due to splitter loss of +3.0 dB.

### VSWR

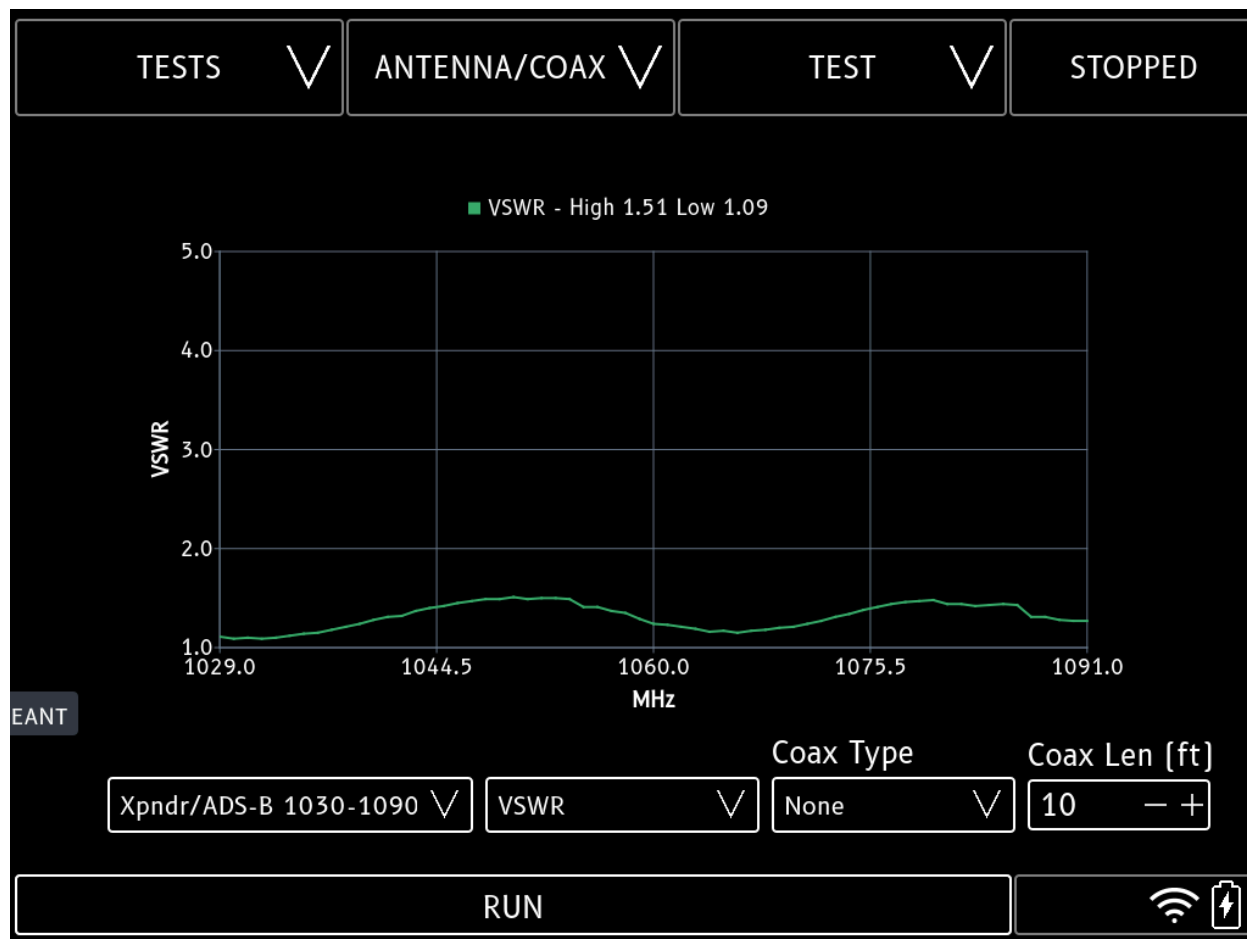

Transponder/ADS-B VSWR without coax loss compensation.

### VSWR with Coax Loss Compensation

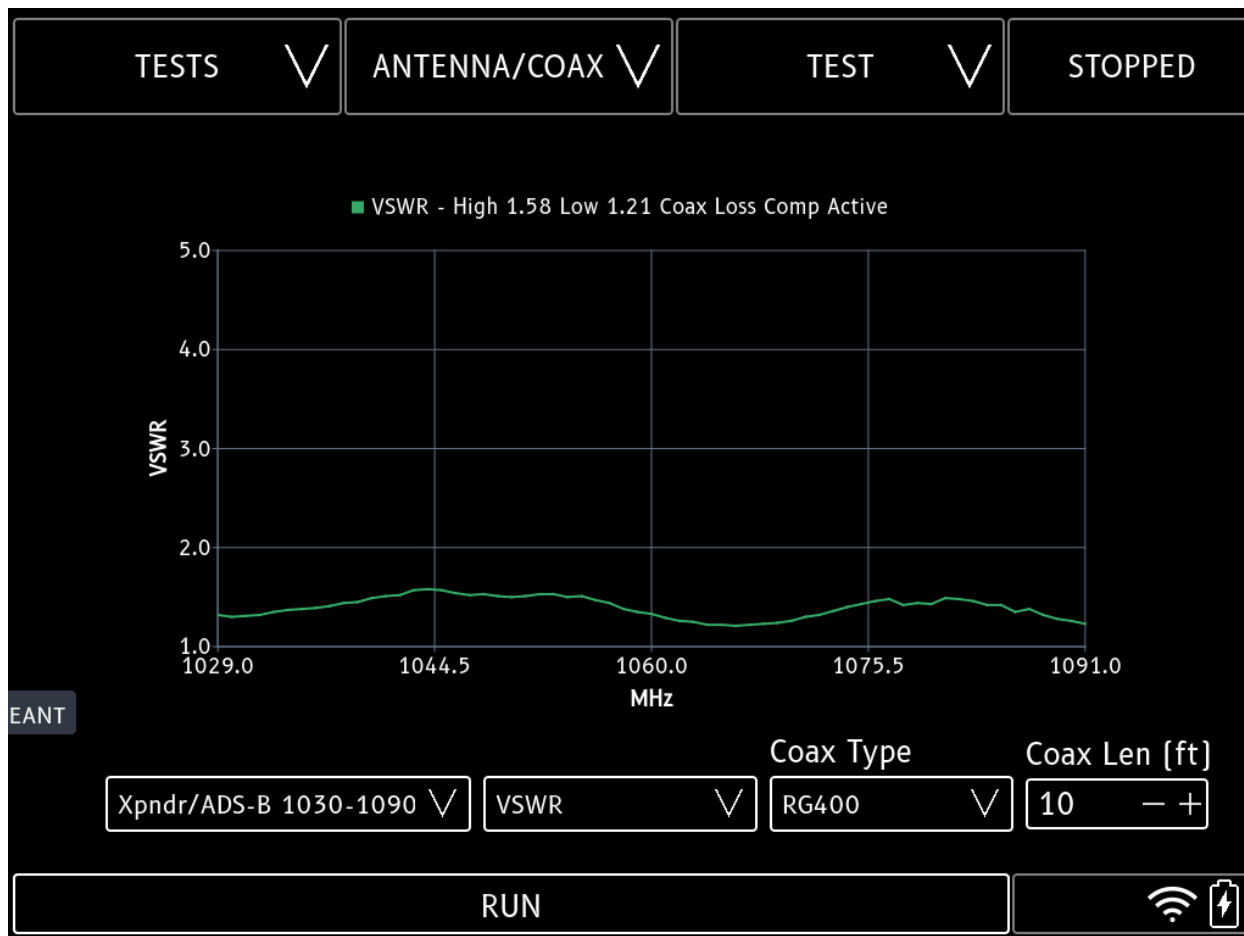

Coax loss can mask unacceptable VSWR. By selecting a Coax Type and Length, the measured VSWR will be compensated for the coax loss.

Estimate length or use the Peak Distance determined in a Distance to Fault test. Length selected should include any test cable.

If loss compensation is undesired, select Coax Type None.

## Distance to Fault with Connected Antenna

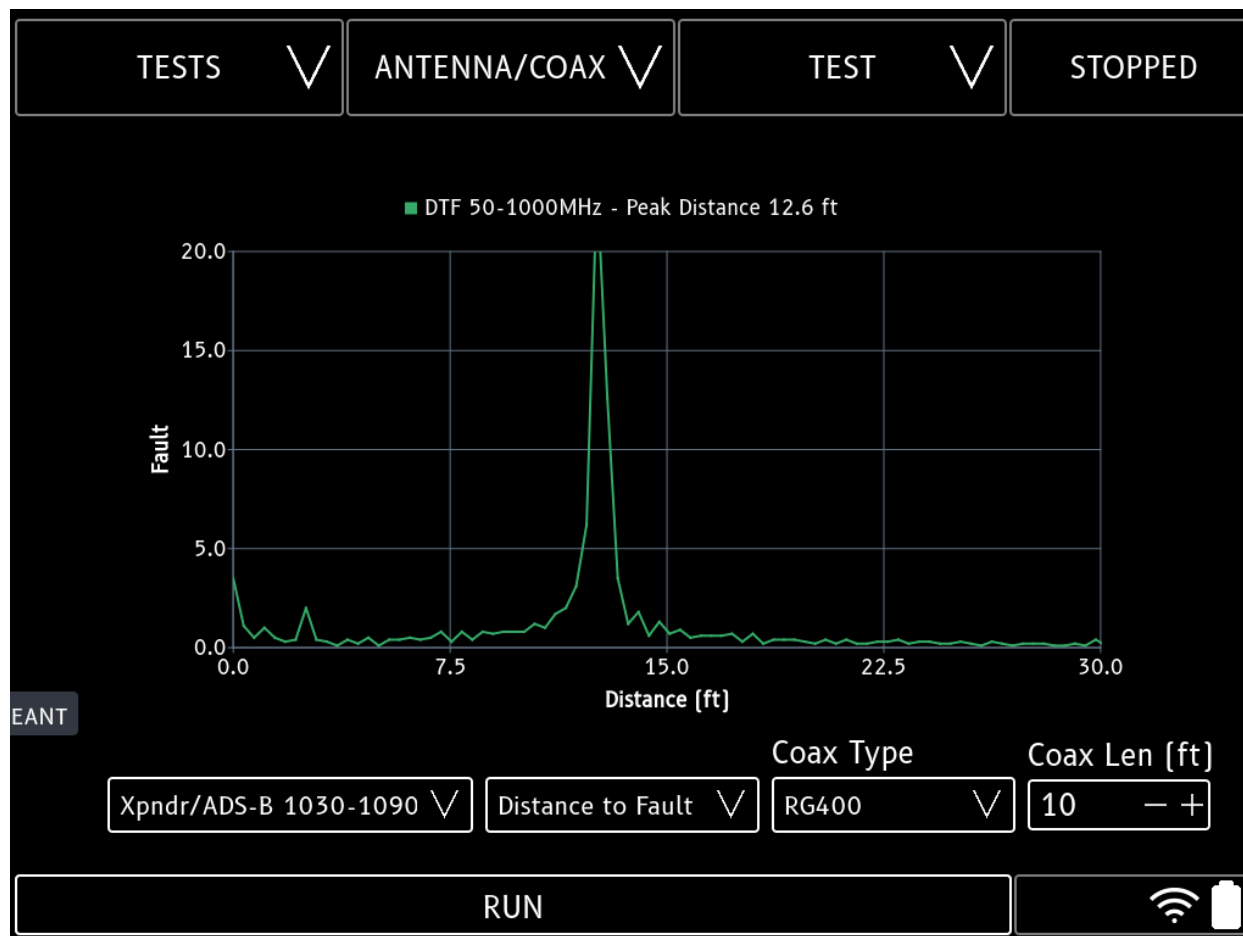

A coax with connected antenna can be tested using the Distance to Fault mode. Discontinuities in the coax, such as connector breaks and coax damage will show as sharp spikes in the display. An antenna will show as a very large spike (this is expected due to the wide frequency sweep of the DTF mode).

Normal coax connection discontinuities will generally be less than a fault value of 4.0. In the above example, a 4 ft test cable was used, and the connection from the test cable to transponder rack connection can be seen at the 4 ft distance.

Distance values will be calculated using the velocity of propagation (VP) for the selected Coax Type. If Coax Type is None, a VP of 0.7 is used (coax VP typically ranges from 0.66 - 0.88). Coax Length is not used in Distance to Fault measurement.

Distance scale can be selected in the mode menu, either Distance to Fault 30' or Distance to Fault 75'.

### Distance to Fault with Connected Load

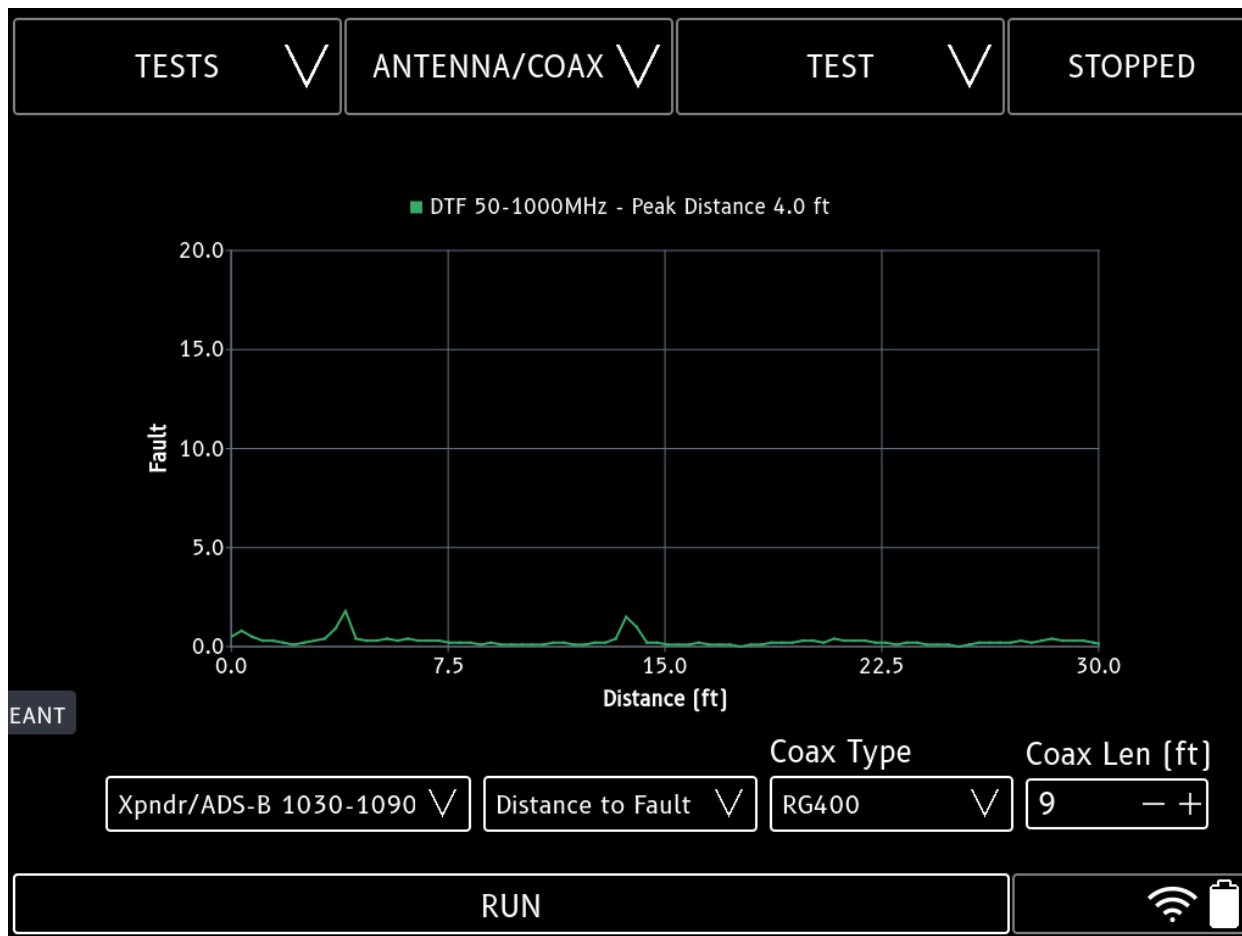

A coax disconnected at the far end will look similar to a connected antenna (although a disconnected coax at the antenna will also have a very poor VSWR). A 50 ohm load can be connected at the far end of the coax, thereby ensuring that the integrity of the far end connection can be tested.

### Distance to Fault with Unacceptable Coax Connection

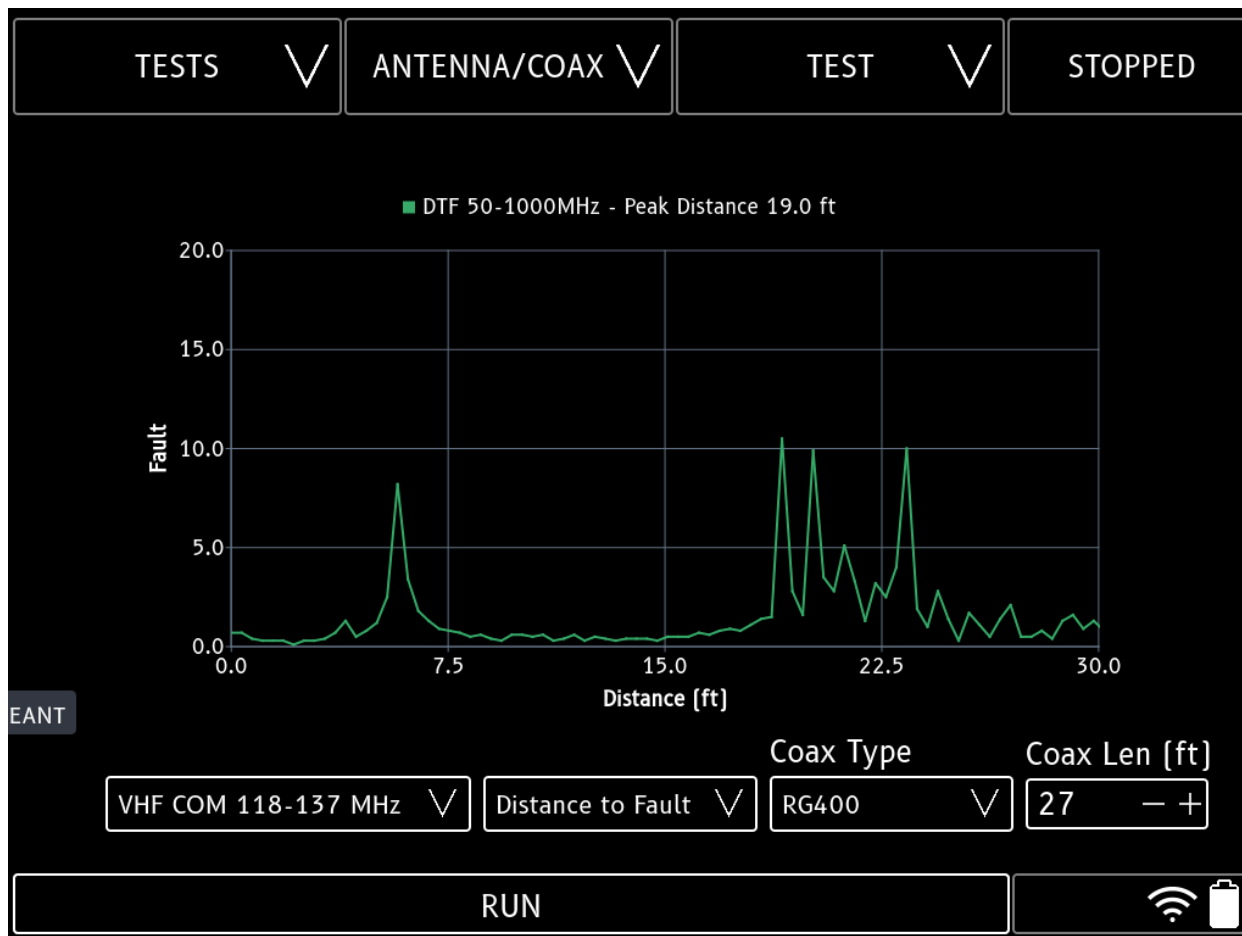

In this example, the test cable connection can be seen at 4 ft, and another connection after the com rack at ~6 ft. This discontinuity is unacceptable and should be investigated.

### Cable Loss

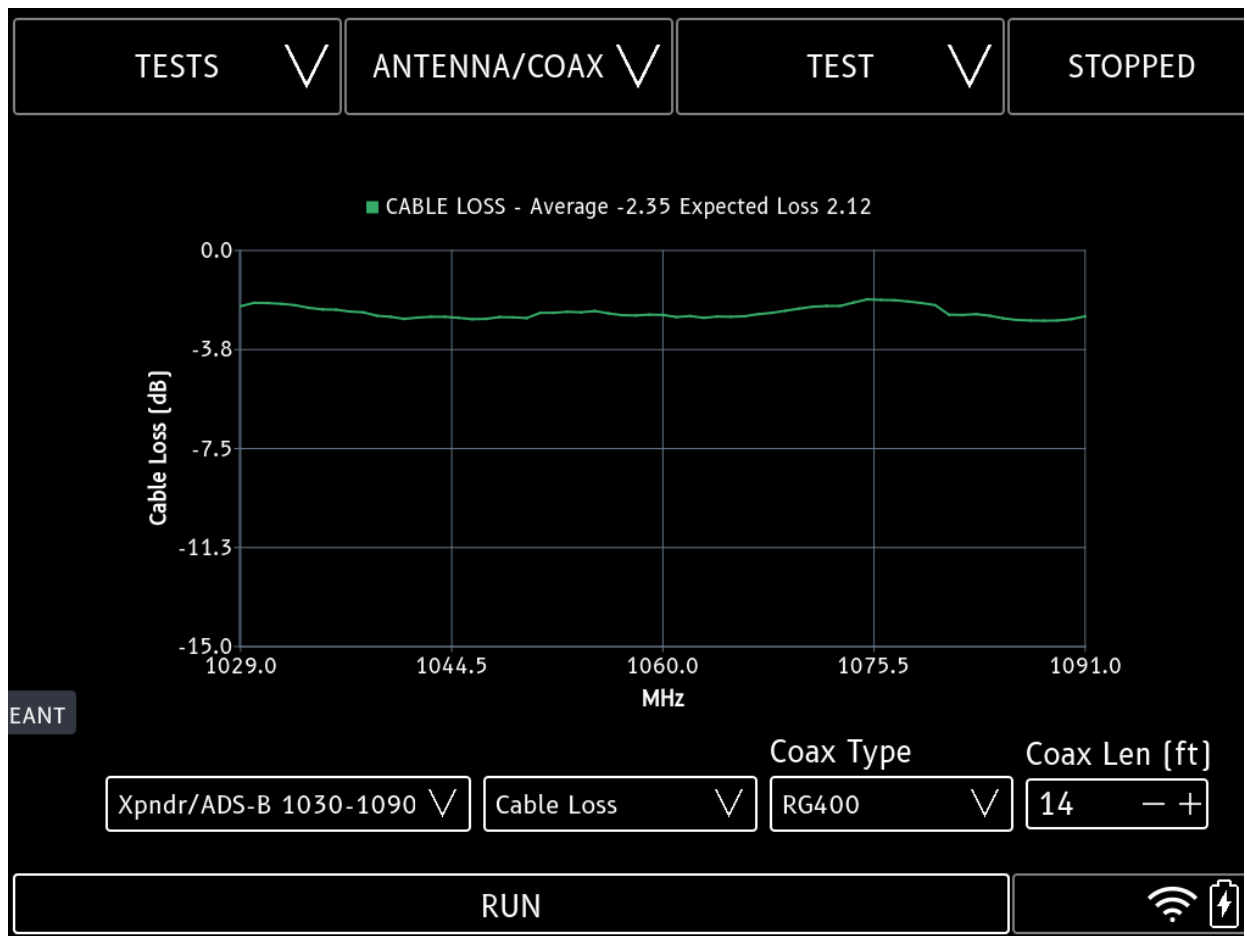

Cable loss can be measured with the far end of the coax left open. If Coax Type and Length is selected, the expected loss is also shown.

Estimate coax length or use the Peak Distance determined in a Distance to Fault test. Length selected should include any test cable.

### Cable Loss with Defective Coax

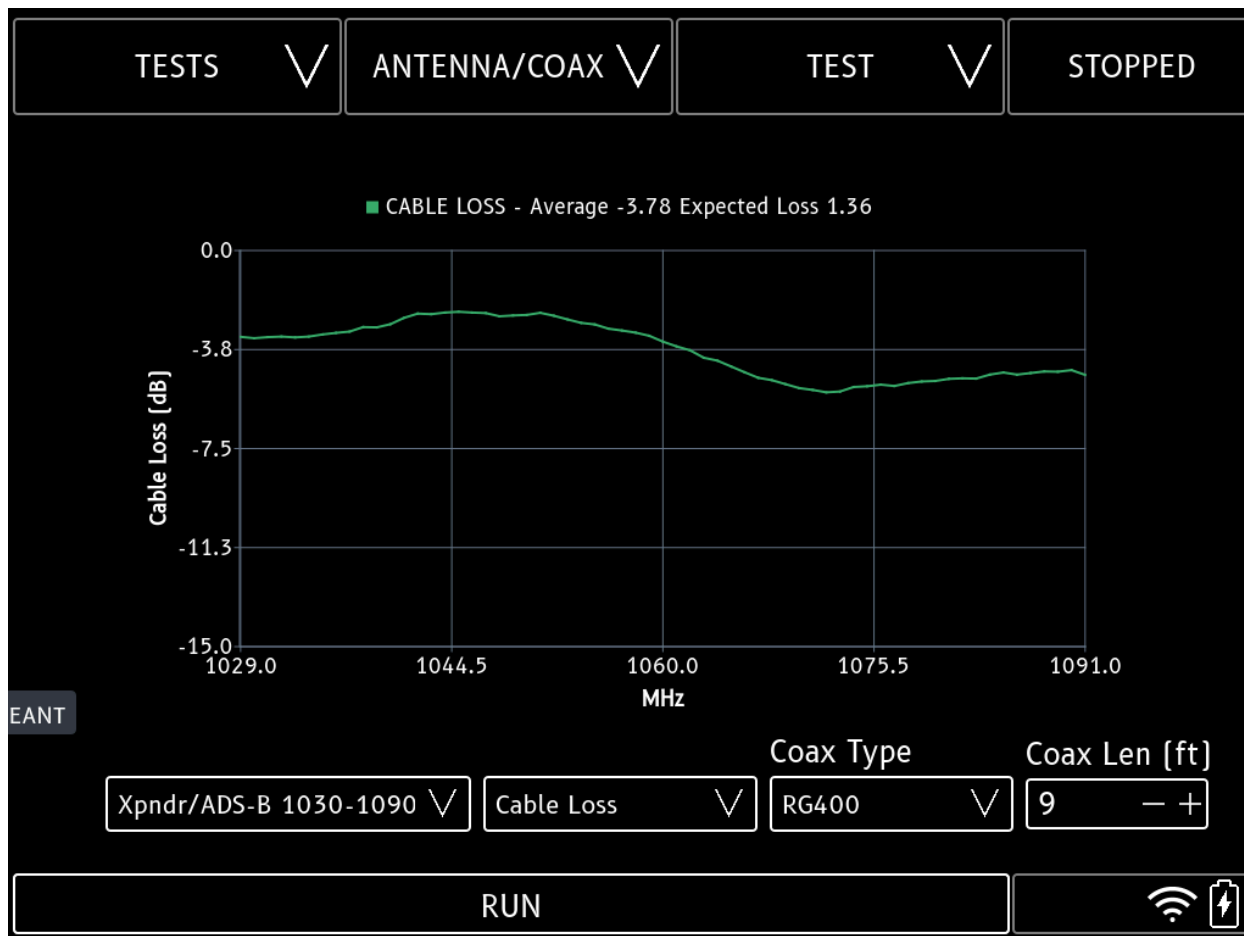

In this example the cable loss is unacceptable.

## Return Loss

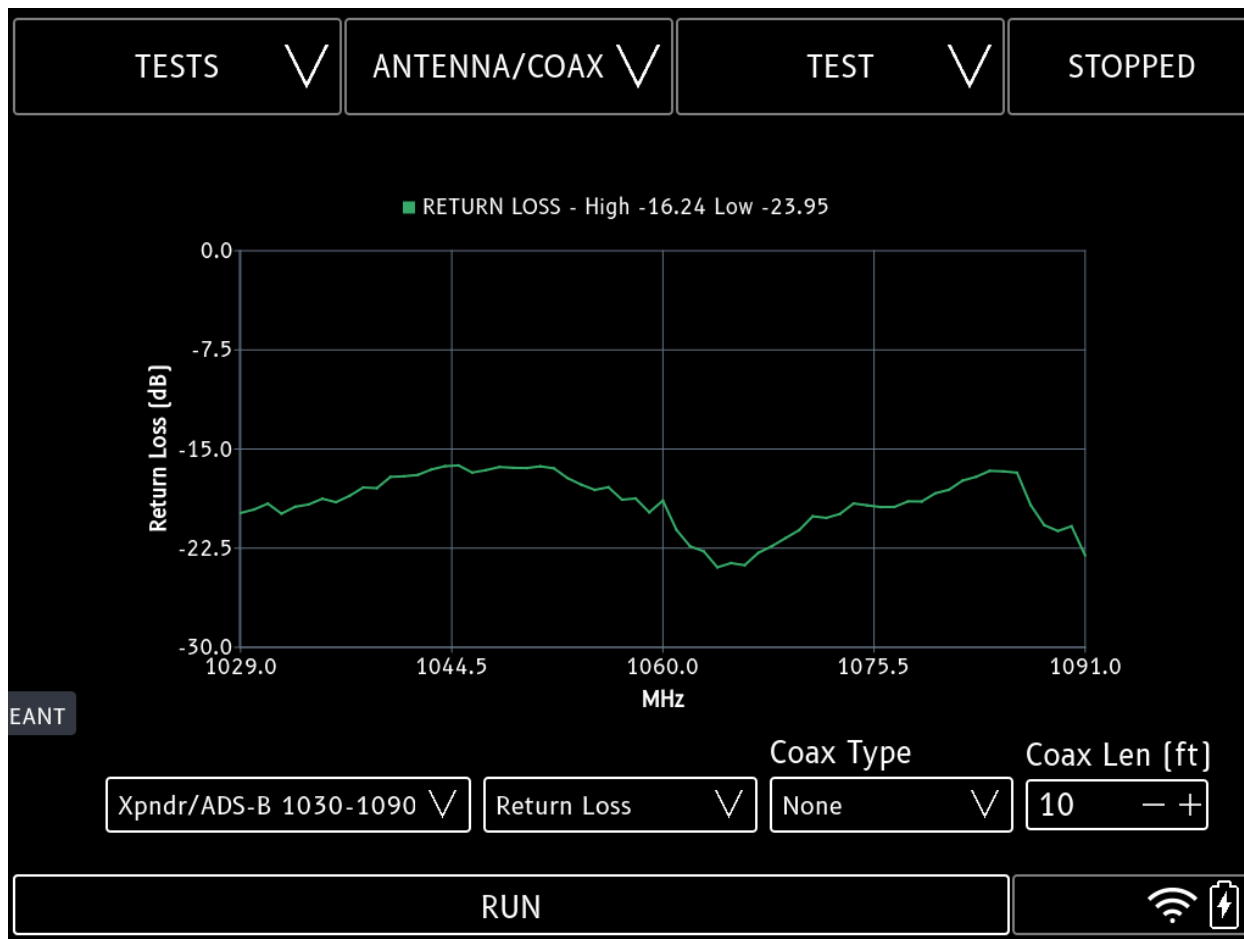

Return Loss is the direct measurement of reflected RF displayed in dB. Return Loss is inversely related to VSWR. Coax Type is not considered in the Return Loss display.

## ANTENNA/COAX Test Controls

|                       |  |
|-----------------------|--|
| <b>EANT</b>           | All Antenna/Coax testing is performed using the External TNC connection  |
| <b>Frequency Band</b> | Band selection based on system type and frequency range. 74 MHz - 1213 MHz.  |
| <b>Test Mode</b>      | Return Loss, VSWR, Cable Loss, Distance to Fault 30', Distance to Fault 75'  |
| <b>Coax Type</b>      | Over 50 different Coax Types can be selected. Coax Type is used for accurate Distance-to-Fault measurements, VSWR Coax Compensation, and Cable Loss expected loss. |
| <b>Coax Len (ft)</b>  | Length of Coax tested. Estimate length or use the Peak Distance determined in a Distance to Fault test. Length selected should include any test cable.             |

Note: Antenna/Coax testing requires internal hardware support. Contact T-RX support at [t-rx\\_support@ccxtechnologies.com](mailto:t-rx_support@ccxtechnologies.com) or [calibration@ccxtechnologies.com](mailto:calibration@ccxtechnologies.com) for upgrade details if message "Internal Hardware Incompatible with Antenna/Coax Test" appears.

## ARINC 429 Test

### RX Filtered

This page represents a live view of specific decoded labels.

The screenshot shows a control interface for an ARINC 429 test. At the top, there are four buttons: 'TESTS', 'ARINC 429', 'RX FILTERED', and 'STOPPED'. Below these are five label selection buttons labeled 'Label 1' through 'Label 5', each with a dropdown menu showing a selected value (247, 150, 136, 111, and 112 respectively). The main display area contains a table of decoded data for these labels. At the bottom, there is a 'RUN' button and status icons for Wi-Fi and battery.

| Time                    | Label | Parameter                     | Value         | SDI | SSM              |
|-------------------------|-------|-------------------------------|---------------|-----|------------------|
| 2021-08-17 10:35:43.848 | 247   | Horizontal Figure of Merit    | 0.000 NM      | 0   | normal operation |
| 2021-08-17 10:35:43.848 | 150   | Universal Time Constant [...] | 6:23:49       | 0   | normal operation |
| 2021-08-17 10:35:43.848 | 136   | Vertical Figure of Merit      | 3699.000 Feet | 0   | normal operation |
| 2021-08-17 10:35:43.848 | 111   | GNSS Longitude                | -76.237 Deg   | 0   | normal operation |
| 2021-08-17 10:35:43.848 | 112   | GNSS Ground Speed             | 427.250 Knots | 0   | normal operation |

|                    |  |
|--------------------|--|
| Label 1 to Label 5 | Select a label to view incoming data.                                      |
| RUN/CANCEL         | Pressing RUN will receive the signal continuously until CANCEL is pressed. |
| < >                | Press the arrow keys to view next or previous values.                      |

## RX All

This page represents a view of all decoded labels.

| Time                    | Label | Parameter                    | Value           | SDI | SSM              |
|-------------------------|-------|------------------------------|-----------------|-----|------------------|
| 2021-08-16 15:07:18.796 | 247   | Horizontal Figure of Merit   | 0.000 NM        | 0   | normal operation |
| 2021-08-16 15:07:18.796 | 174   | East/West Velocity           | 38.000 Knots    | 0   | normal operation |
| 2021-08-16 15:07:18.796 | 165   | Vertical Velocity            | -1.000 Feet/Min | 0   | normal operation |
| 2021-08-16 15:07:18.796 | 150   | Universal Time Constant [... | 6:23:49         | 0   | normal operation |
| 2021-08-16 15:07:18.796 | 136   | Vertical Figure of Merit     | 3699.000 Feet   | 0   | normal operation |
| 2021-08-16 15:07:18.796 | 125   | Universal Time Coordinate... | 623.800 Hr:Min  | 0   | normal operation |
| 2021-08-16 15:07:18.796 | 121   | GNSS Longitude Fine          | 0.000 Degrees   | 0   | normal operation |
| 2021-08-16 15:07:18.796 | 112   | GNSS Ground Speed            | 427.250 Knots   | 0   | normal operation |
| 2021-08-16 15:07:18.796 | 111   | GNSS Longitude               | -76.237 Deg     | 0   | normal operation |
| 2021-08-16 15:07:18.796 | 110   | GNSS Latitude                | 44.978 Deg      | 3   | normal operation |

| Label            | Parameter                  | Value           | Encoding |
|------------------|----------------------------|-----------------|----------|
| 247              | Horizontal Figure of Merit | 0.000 NM        | bnr      |
| Minimum Interval | Maximum Interval           | Discrete States |          |
| 200.0            | 200.0                      |                 |          |

|                   |   |
|-------------------|---|
| <b>REFRESH</b>    | Press REFRESH and observe that the Main Table has been populated with the most recent decoded data.   |
| < >               | Press the arrow keys to view the next or previous pages of the Main Table.  |
| <b>RUN/CANCEL</b> | Pressing RUN will receive the signal continuously until CANCEL is pressed.  |
| <b>MAIN TABLE</b> | The Main Table populates with Time, Label, Parameter, Value, SDI (Source/Destination Identifiers), and SSM (Sign Status Matrix) data according to the ARINC 429 protocol. |
| <b>SUB TABLE</b>  | Select a given row in the Main Table, and the Sub Table will be populated with more information about the selected row.   |

## RX Raw

This page represents a view of the raw ARINC 429 data.

| Time                    | Label | Raw Data |
|-------------------------|-------|----------|
| 2021-08-16 15:07:18.796 | 247   | 610200e5 |
| 2021-08-16 15:07:18.796 | 174   | 6026003e |
| 2021-08-16 15:07:18.796 | 165   | 7ffe0ae  |
| 2021-08-16 15:07:18.796 | 150   | 632f8816 |
| 2021-08-16 15:07:18.796 | 136   | 61ce607a |
| 2021-08-16 15:07:18.796 | 125   | 188e0aa  |
| 2021-08-16 15:07:18.796 | 121   | 68ac008a |
| 2021-08-16 15:07:18.796 | 112   | 61ab4052 |
| 2021-08-16 15:07:18.796 | 111   | 79393092 |
| 2021-08-16 15:07:18.796 | 110   | 63ff8312 |

75 total entries

| Label | SDI | Binary Data Field        | Hex Data Field | SSM |
|-------|-----|--------------------------|----------------|-----|
| 247   | 0   | 011000010000001000000000 | 610200         | 3   |

|                   |   |
|-------------------|---|
| <b>REFRESH</b>    | Press REFRESH and observe that the Main Table has been populated with the most recent raw data.   |
| < >               | Press the arrow keys to view the next or previous pages of the Main Table.  |
| <b>RUN/CANCEL</b> | Pressing RUN will receive the signal continuously until CANCEL is pressed.  |
| <b>MAIN TABLE</b> | The Main Table populates with Time, Label, and Raw Data according to the ARINC 429 configured protocol.   |
| <b>SUB TABLE</b>  | Select a given row in the Main Table, and the Sub Table will be populated with the selected row's Label, SDI, Binary Data Field, Hex Data Field, and SSM. |

## TX AHRS DIR

TESTS ▾
ARINC 429 ▾
TX AHRS DIR ▾
STOPPED

Enabled    Label 314    True Heading     Deg/180

SDI  0  1  2  3    SSM  FAILURE  NO DATA  TEST  NORMAL

Enabled    Label 320    Magnetic Heading     Deg/180

SDI  0  1  2  3    SSM  FAILURE  NO DATA  TEST  NORMAL

Enabled    Label 324    Pitch Angle     Deg/180

SDI  0  1  2  3    SSM  FAILURE  NO DATA  TEST  NORMAL

Enabled    Label 325    Roll Angle     Deg/180

SDI  0  1  2  3    SSM  FAILURE  NO DATA  TEST  NORMAL

RUN

|                   |   |
|-------------------|---|
| <b>Enabled</b>    | Enable or disable the ARINC 429 label transmission                          |
| <b>SDI</b>        | Source/Destination Identifier value   |
| <b>SSM</b>        | Sign Status Matrix value  |
| <b>RUN/CANCEL</b> | Pressing RUN will transmit the signal continuously until CANCEL is pressed. |

## TX AHRS ACCEL

TESTS ▾
ARINC 429 ▾
TX AHRS ACCEL ▾
STOPPED

Enabled    Label 332    Body Lateral Acceleration     g

SDI  0  1  2  3    SSM  FAILURE  NO DATA  TEST  NORMAL

Enabled    Label 333    Body Normal Acceleration     g

SDI  0  1  2  3    SSM  FAILURE  NO DATA  TEST  NORMAL

Enabled    Label 340    Inertial Yaw Rate     deg/sec

SDI  0  1  2  3    SSM  FAILURE  NO DATA  TEST  NORMAL

Enabled    Label 365    Inertial Vertical Velocity [EFI]     ft/min

SDI  0  1  2  3    SSM  FAILURE  NO DATA  TEST  NORMAL

RUN

|            |   |
|------------|---|
| Enabled    | Enable or disable the ARINC 429 label transmission                          |
| SDI        | Source/Destination Identifier value   |
| SSM        | Sign Status Matrix value  |
| RUN/CANCEL | Pressing RUN will transmit the signal continuously until CANCEL is pressed. |

## TX ADC/RADALT

TESTS 
ARINC 429 
TX ADC/RADALT 
STOPPED

Enabled

Label 102

Selected Altitude

Ft

SDI  0  1  2  3
SSM  FAILURE  NO DATA  TEST  NORMAL

Enabled

Label 235

Baro Correction

ins Hg

SDI  0  1  2  3
SSM  NO DATA  TEST  NORMAL

Enabled

Label 203

Pressure Altitude

Ft

SDI  0  1  2  3
SSM  FAILURE  NO DATA  TEST  NORMAL

Enabled

Label 204

Baro Corrected Altitude

Ft

SDI  0  1  2  3
SSM  FAILURE  NO DATA  TEST  NORMAL

Enabled

Label 206

Computed Airspeed

Kts

SDI  0  1  2  3
SSM  FAILURE  NO DATA  TEST  NORMAL

Enabled

Label 164

Radio Height

Ft

SDI  0  1  2  3
SSM  FAILURE  NO DATA  TEST  NORMAL

RUN

|                   |   |
|-------------------|---|
| <b>Enabled</b>    | Enable or disable the ARINC 429 label transmission                          |
| <b>SDI</b>        | Source/Destination Identifier value   |
| <b>SSM</b>        | Sign Status Matrix value  |
| <b>RUN/CANCEL</b> | Pressing RUN will transmit the signal continuously until CANCEL is pressed. |

## Test Config

TESTS ▾
ARINC 429 ▾
TEST CONFIG ▾
STOPPED

RX1 Enabled

RX2 Enabled

TX1 Enabled

RX1 Data Speed [Kbps]

12.5    100

RX2 Data Speed [Kbps]

12.5    100

TX1 Data Speed [Kbps]

12.5    100

RX1 Equipment

00B - Global Positionir ▾

RX2 Equipment

None ▾

TX1 Transmit Rate [ms]

500

CLEAR ALL TABLE

CLEAR RAW TABLE

|                        |  |
|------------------------|--|
| RX1 or RX2 Enabled     | Enable or disable the ARINC 429 receiver.                                    |
| Data Speed [kHz]       | Select 12.5 for the low speed data rate or 100 for the high speed data rate. |
| Equipment              | Select the Equipment ID for decoding the ARINC 429 messages on channel one.  |
| CLEAR ALL TABLE        | Press to clear all data in the ALL table.                                    |
| CLEAR RAW TABLE        | Press to clear all data in the RAW table.                                    |
| TX1 Enabled            | Enable or disable the ARINC 429 transmitter.                                 |
| TX1 Transmit Rate (ms) | Label repetition rate.   |

## GPS Generator

TESTS ▾
GPS GENERATOR ▾
TEST ▾
STOPPED

Latitude °  
 - +

Latitude '  
 - +

Longitude °  
 - +

Longitude '  
 - +

Track °  
 - +

Groundspeed kts  
 - +

Vert Track °  
 - +

Altitude MSL ft  
 - +

GPS/SBAS Satellites

|  |                              |
|--|------------------------------|
| GPS PRN 2  | Azimuth 167.9 Elevation 39.1 |
| GPS PRN 5  | Azimuth 98.6 Elevation 17.8  |
| GPS PRN 10   | Azimuth 296.0 Elevation 26.9 |
| GPS PRN 13   | Azimuth 49.1 Elevation 22.9  |
| GPS PRN 15   | Azimuth 50.8 Elevation 52.4  |
| SBAS PRN 135[48] WAAS  | Azimuth 241.7 Elevation 20.9 |
| Lat 40.6260° Lon -74.6700° [40° 37.56' -74° 40.20'] / UTC: 2022/11/14 13:59:57 |                              |
| Gndspeed 0kts / Track 300° / MSL Alt 100ft / GPS Alt [HAE] -11ft               |                              |

CANCEL

|                        |  |
|------------------------|--|
| <b>Latitude°</b>       | Starting Latitude in whole or decimal degrees. N is positive, S is negative.   |
| <b>Latitude'</b>       | Starting Latitude decimal minutes. Leave at 0 if decimal degrees are used.   |
| <b>Longitude°</b>      | Starting Longitude in whole or decimal degrees. E is positive, W is negative. Initial starting value, will not change with speed or track changes. |
| <b>Longitude'</b>      | Starting Longitude decimal minutes. Leave at 0 if decimal degrees are used.  |
| <b>Track°</b>          | Track in degrees. Magnetic Track if magnetic variation is configured.  |
| <b>Groundspeed kts</b> | Groundspeed in knots.  |
| <b>Vert Track°</b>     | Vertical Track in degrees. Positive climbing, negative descending.   |
| <b>Altitude MSL ft</b> | WGS84 MSL altitude. Converted to GPS HAE.  |

### GPS Test Config

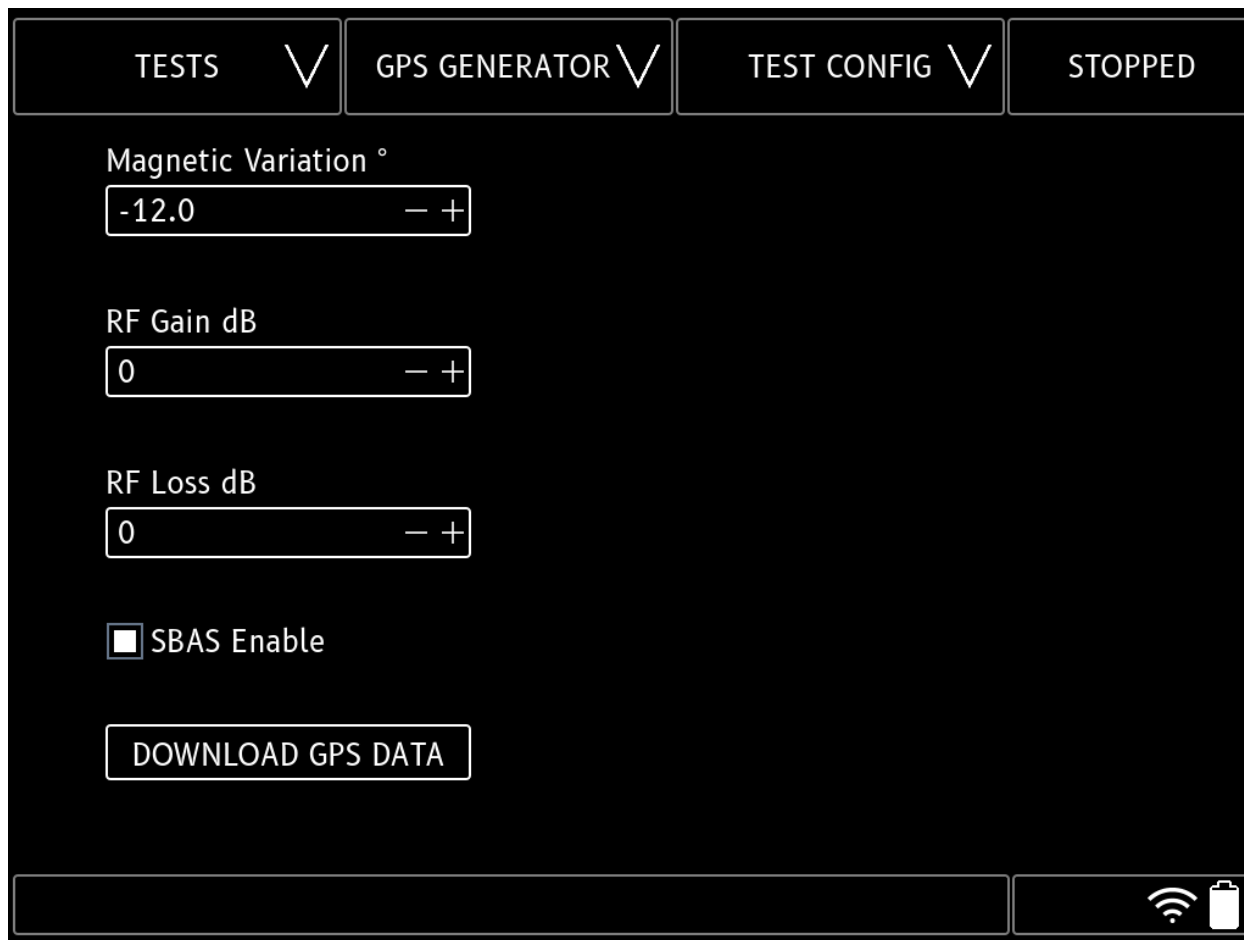

|                            |   |
|----------------------------|---|
| <b>Magnetic Variation°</b> | Magnetic Variation of configured position. W is negative, E positive. Set to 0 if True Track is required.   |
| <b>RF Gain dB</b>          | 0 dB gain is nominal. Range +-10 dB.  |
| <b>RF Loss dB</b>          | Coax loss for direct connection to a receiver, or combined loss of coax and antenna coupler. (CCX GPS antenna coupler+coax: 12 dB).   |
| <b>SBAS Enable</b>         | SBAS Satellite can be enabled or disabled.  |
| <b>Download GPS Data</b>   | Select to download current GPS Almanac and Ephemeris. Requires active Ethernet or WiFi connection. Data will be persistent and active connection is not required for GPS Generator use. |

## GPS/SBAS Satellite Displayed Data

|                     |   |
|---------------------|---|
| <b>GPS PRN</b>      | PRN of generated GPS satellite 1-32 with elevation and azimuth  |
| <b>SBAS PRN</b>     | SBAS Satellite PRN, NMEA Number ( ) and system name (WAAS, EGNOS, MSAS. or GAGAN) with elevation and azimuth                            |
| <b>Lat / Lon</b>    | Latitude/Longitude of generated position in decimal degrees and degrees / decimal minutes   |
| <b>Date/Time</b>    | UTC date and time of generated position. Will always be several hours earlier than actual time due to use of downloaded Ephemeris data. |
| <b>Groundspeed</b>  | Groundspeed of generated position. Speed changes integrated at 8 kts/sec.   |
| <b>Track</b>        | Track of generated position. Track changes integrated at 180°/min   |
| <b>MSL Altitude</b> | MSL altitude derived from WGS84 model of GPS HAE  |
| <b>HAE Altitude</b> | GPS Height Above Ellipsoid (HAE)  |

## GPS Generator Usage

The GPS Generator is connected to the T-RX™ USB port using the supplied USB Type A to Type B cable. The GPS Generator TNC output port should be connected to a GPS antenna coupler or directly to a GPS receiver. The GPS Generator RF output port is DC blocking and safe to connect to DC bias supplying GPS receivers.

Before use, download the latest Ephemeris and Almanac files by selecting **DOWNLOAD GPS DATA** in the GPS TEST CONFIG page. An internet connection is needed to download the files (active internet connection is not needed for the GPS Test).

The connected cable loss or combined GPS Coupler+Cable Loss should be entered in the GPS TEST CONFIG PAGE in the RF Loss field. RF Gain can be left at 0 for a nominal RF signal level.

Select **RUN** from the GPS TEST page. The generated data will populate the GPS/SBAS Satellites text area.

Once a GPS lock is achieved, other tests may be run (such as ADS-B OUT) simultaneously with GPS Generator. The satellite icon in the lower right of the display will indicate if the test is running.

## GPS Generator Notes

Simultaneous use of GPS Generator Test and XPNDR Test is not recommended due to T-RX resources required by both tests.

GPS Generator is not intended or approved for open air transmission. Only intended for a direct connection to a GPS receiver or a GPS antenna coupler

If GPS satellite RF levels are too low, RF Gain can be adjusted up for appropriate signal levels. Too much gain (or incorrectly set coupler loss) will cause cross-correlation of the GPS satellites. This will usually be seen as very high GPS signal levels and a rapid appearance and disappearance of satellite PRNs. Lower the gain until satellites are stable.

GPS Receiver may take up to 25 minutes to produce a lock with live satellites if almanac is reloaded by GPS receiver.

GPS Generator UTC time will be several hours older than actual UTC due to use of downloaded Ephemeris.

GPS Generator is compatible with any GPS antenna coupler. GPS antenna coupler loss must be entered in GPS TEST CONFIG page.

GPS receivers will not switch from live to generated signals or vice versa without a power cycle. If GPS generator is restarted GPS receiver should be power cycled.

It is important that the GPS antenna coupler does not allow reception of any live GPS satellites while in use. Some gps antenna couplers tested do not have enough isolation to be used out of doors due to spurious reception of live GPS satellites. The CCX Technologies antenna coupler is recommended for maximum isolation.

SBAS system selection will be automatic based on service area of initial position. Starting positions outside of a SBAS service area will automatically deselect the SBAS satellite and use 6 GPS satellites. SBAS may also be manually deselected in the GPS TEST CONFIG page.

Some GPS receivers will report an antenna failure if a direct connection is made from the GPS Generator and the receiver. A Bias-Tee connected load of approximately 200 ohms will simulate an active antenna and prevent failure reporting. An acceptable Bias-Tee and load is InStock Wireless GPS220 splitter and TT0601 termination.



**WARNING:** Spurious ADS-B targets may be generated if GPS receiver being tested is connected to an ADS-B OUT system and generated GPS position is above ground elevation. Ensure ADS-B OUT systems do not send spurious data over the air by turning off ADS-B OUT system or using an L-Band coupler to block ADS-B data from being broadcast. Alternatively, ensure generated GPS altitude is at ground level for the generated position.

## Test Reports

TESTS ▾
XPNDR ▾
TEST INFO ▾
STOPPED

**Aircraft**

**Work Order**

**Technician**

**Time Zone**

**Test Report**

**Recipient Email Address**

|                      |   |
|----------------------|---|
| <b>Aircraft</b>      | Enter aircraft registration or other identifying information                  |
| <b>Work Order</b>    | Enter the work order number   |
| <b>Technician</b>    | Enter the technician's name or initials                                       |
| <b>Time Zone</b>     | Time Zone used in report time stamp   |
| <b>Test Report</b>   | Select Report to view or send via email                                       |
| <b>Email Address</b> | Enter email address of report recipient                                       |
| <b>View Report</b>   | View the selected report on screen  |
| <b>Send Report</b>   | Report will be emailed to the recipient. Requires Ethernet or WiFi connection |

View Report

TESTS ▾
XPNDR ▾
TEST INFO ▾
STOPPED

- 1 +

+

-

◀ ▶

⬆ ⬇





### T-RX TEST REPORT

**TEST: XPNDR MODE-A/C/S**

Aircraft: N123XX  
 Work Order: A0001  
 Technician: TZ  
 Date: 2021-09-23 13:27:43 GMT-0400 (EDT)

|                               |                            |
|-------------------------------|----------------------------|
| Mode A / S Code               | 1200 / 1200                |
| Mode C / S Altitude           | -1000 / -1000              |
| Mode S Address                | N555XY A71422 (51612042)   |
| Flight Status                 | AIR                        |
| Valid/Invalid Address         | ✓                          |
| Mode S Squitter DF11          | ✓                          |
| Mode S UF11 AllCall Reply     | ✓                          |
| Mode S ATCRBS/S AllCall Reply | ✓                          |
| Flight ID                     | W777                       |
| Additional Replies            | ADS-B DF17 Squit DF20 DF21 |
| Diversity Isolation           | N/A                        |
| Transmit Frequency            | 1090.0 MHz                 |
| Mode A/C SLS                  | ✓                          |
| Mode A/C MTL                  | -71.0 dBm                  |
| Mode S MTL                    | -73.0 dBm                  |
| Transmit Power                | 53.7 dBm 237W              |

Sample Test Report



## T-RX TEST REPORT

**TEST: XPNDR MODE-A/C/S**

**PASS**

Aircraft:  
Work Order:  
Technician: TM  
Date: 2025-03-11 10:51:29 GMT-0400 (EDT)

|                                 |  |
|---------------------------------|--|
| Mode A / S Code (DF5 ID)        | 1200 / 1200                                  |
| Mode C / S Altitude (DF4 AC)    | -1000 / -1000                                |
| Mode S Address (DF11 AA)        | USA N555XY A71422 (51612042)                 |
| Flight/Vert Status/RI DF4/5 DF0 | FS=0 / VS=0 RI=11 MAX A/S >150kt<300kt / AIR |
| Valid/Invalid Address           | ✓  |
| Mode S Squitter DF11            | ✓  |
| Mode S UF11 AllCall Reply       | ✓  |
| Mode S ATRBS/S AllCall Reply    | ✓  |
| Flight ID (BDS 2,0)             | W777__                                       |
| Additional Replies              | DF16 ADS-B DF17 Squit DF20 DF21              |
| Diversity Isolation             | N/A  |
| Capability                      | CA=7 Level 2                                 |
| Mode A/C SLS                    | ✓ / ✓  |
| Mode A/C MTL                    | -70.0 dBm / -70.0 dBm diff 0.0               |
| Mode S MTL                      | -73.0 dBm                                    |
| Transmit Frequency              | 1090.0 MHz                                   |
| Transmit Power                  | 53.6 dBm 230W                                |

## T-RX Hardware Specifications

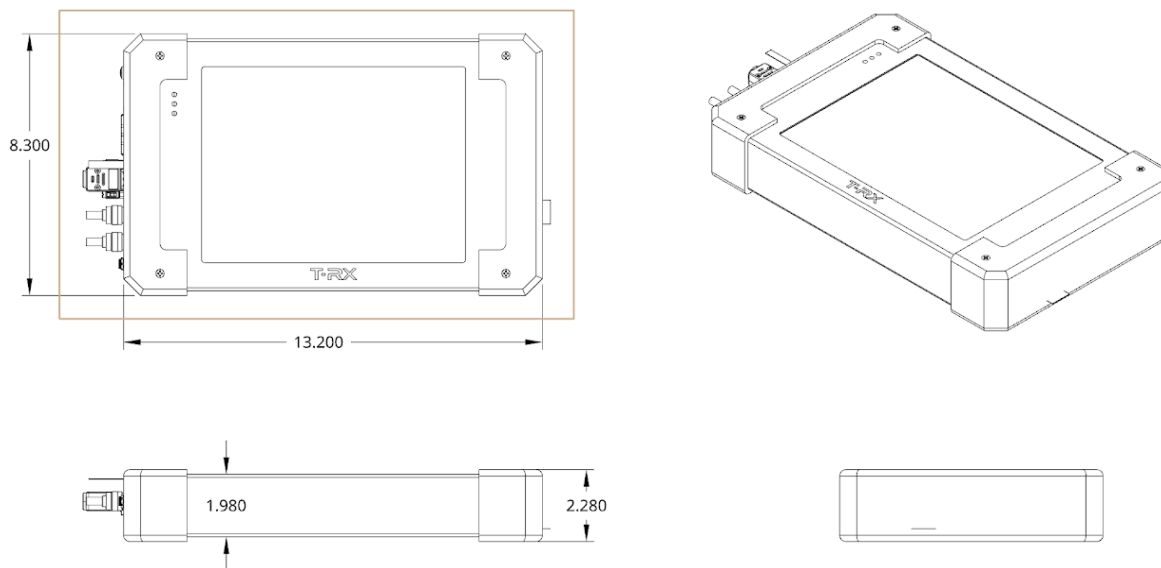

|                        |  |
|------------------------|--|
| <b>Weight</b>          | 5.07 lbs (2.3 kg)                              |
| <b>Length</b>          | 13.2 inches (33.5 cm)                          |
| <b>Width</b>           | 8.3 inches (21.1 cm)                           |
| <b>Height</b>          | 2.0 inches (5.1 cm)                            |
| <b>Case</b>            | Aluminum                                       |
| <b>Screen Size</b>     | 10.4 inches (26.4 cm)                          |
| <b>Battery Type</b>    | Li-ion smart battery                           |
| <b>Battery Voltage</b> | ≡ 15VDC  |
| <b>Charging Input</b>  | ≡ 24VDC @ 2.5A                                 |
| <b>AC Charger</b>      | ≡ 24VDC Output / 100-240 VAC<br>50-60 Hz Input |
| <b>Operating Temp</b>  | -20C <-> +50C                                  |

## T-RX RF Specifications

Frequency Range and Signal Modulation:

- HF Com 5-22 MHz, 1020 Hz USB/AM, 1 KHz spacing
- VHF Com 118.000 - 136.995, 1020 Hz AM, 8.33 KHz spacing (0.005 channels)
- Marker Beacon 75 MHz, AM Outer/Middle/Inner
- VOR 108.00 - 117.95 MHz, 30/9960 Hz AM/FM, 1020 Hz AM, 50 KHz spacing
- Localizer 108.10 - 111.95 90/150 Hz AM, 1020 Hz AM, 50 KHz spacing
- Glideslope 329.15 - 335.00 MHz 90/150 Hz AM, 50 KHz spacing
- UAT ADS-B 978 MHz
- ATCRBS/Mode-S/1090 ADS-B 1030/1090 MHz
- GPS Generator 1575.42 MHz, GPS L1 C/A code and SBAS. RF output DC blocking for direct connection to GPS receivers or antenna couplers
- Antenna/Coax testing CW 74 MHz - 1213 MHz in selected bands, 50 MHz - 1000 MHz  
Distance to Fault

Frequency Stability +/- 1 ppm

VOR/LOC/GS Output level: 0.0 <-> -107.0 dBm +/- 3 dB (Max signal ~-2.0 dBm)

ILS Output level: 0.0 <-> -48.0 dBm (Uncalibrated)

VHF COM Output level: 0.0 <-> -110.0 dBm +/- 3 dB (Max signal ~-2.0 dBm)

HF COM Output level: 0.0 <-> -110.0 dBm +/- 4 dB

(HF COM Max signal ~-2.0 dBm, decreases linearly below 20 MHz)

AM Modulation accuracy: 1%

Marker Modulation accuracy: 1%

VOR AM Modulation accuracy: 1%

VOR FM Modulation accuracy +/- 25 Hz peak deviation

VOR/LOC/GS Tone Frequency accuracy 0.002%

VOR Bearing accuracy +/- 0.1 degree

Localizer DDM accuracy: +/- 0.0015 DDM

Glideslope DDM accuracy: +/- 0.003 DDM

ATCRBS/Mode-S MTL accuracy +/- 2 dB

ATCRBS/Mode-S TX Power accuracy: +/- 2 dB

VSWR accuracy: 20% @2.0 VSWR

Return Loss accuracy: 1.0 dB

Cable Loss accuracy: 0.5 dB

Distance to Fault accuracy: +/- 1 ft

EANT (External Antenna) port input power: < 0 dBm (1 mW)

DRCT (Direct) port input power: < 44 dBm (25W) CW RF / < 59 dBm (800W) Pulse RF

## Regulatory Compliance

T-RX™ fully complies with the following regulatory testing requirements:

Transponder testing: FAR 43 Appendix F / FAR 43 Appendix E(c) (transponder portion) / CAR 571 Appendix F / EASA 2011-15R2

ELT Testing: FAR 91.207(d)(4) / CAR 571 Appendix G

## GPS Module Hardware Specifications

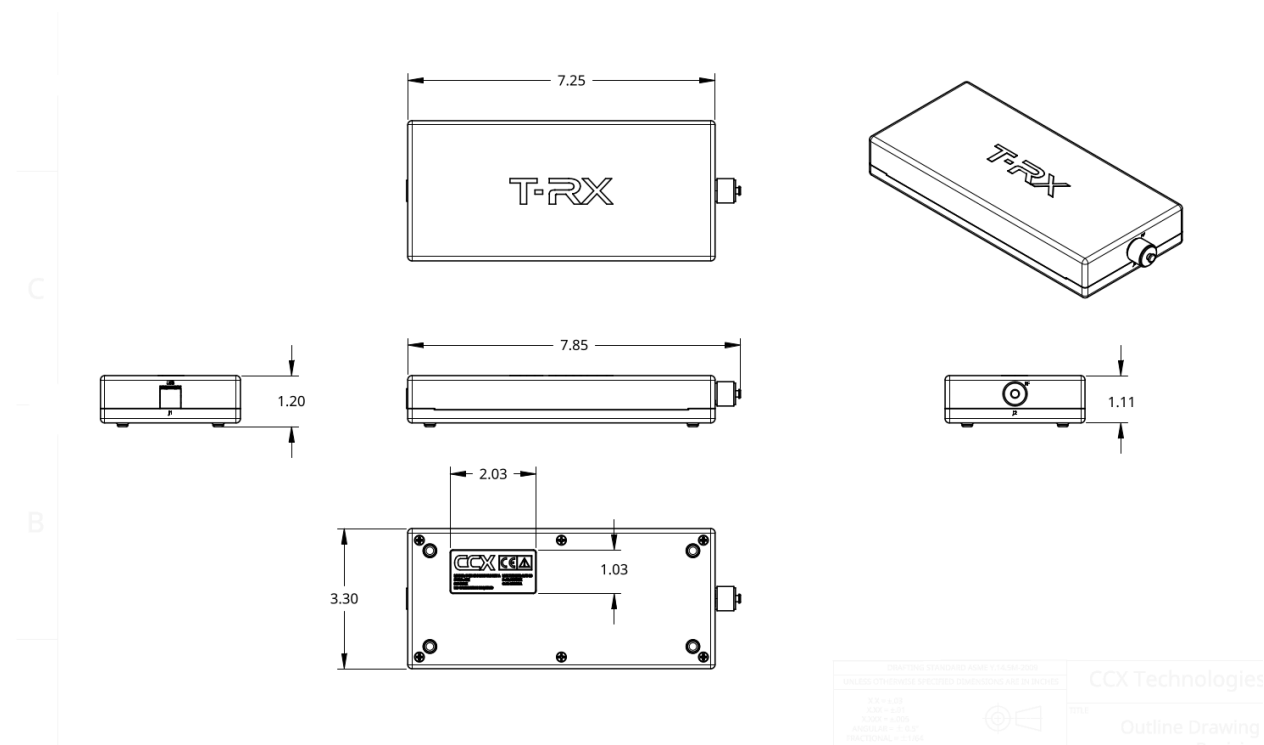

|               |                       |
|---------------|-----------------------|
| <b>Weight</b> | 1.50 lbs (0.68 kg)    |
| <b>Length</b> | 7.8 inches (19.81 cm) |
| <b>Width</b>  | 3.3 inches (8.38 cm)  |
| <b>Height</b> | 1.2 inches (3.05 cm)  |
| <b>Case</b>   | Aluminum              |

## GPS Module RF Specifications

GPS Generator Output Level -135 dBm <-> -105 dBm, Loss compensation 0-50 dB

## Troubleshooting

**Problem:** T-RX™ will not power on.

**Suggested Action:** Does the battery have sufficient charge? Plug-in the provided AC adapter. Try powering your T-RX™. If the unit powers, keep the T-RX™ connected to external power until the battery is fully charged. If the T-RX™ does not stay powered after charging is complete, the battery may need to be replaced.

**Problem:** The touch screen indicates I am pressing on a different section of the screen other than where I touch.

**Suggested Action:** Perform a screen calibration per the section above titled, *How to calibrate the T-RX™ touchscreen*.

## How do I connect to Remote Support?

Ensure your T-RX is connected to a network with Internet access. Select CONFIGURE/ABOUT/SUPPORT. Select "Enable Remote Support". The circle labelled Remote Support Active automatically turns green if it's connected with CCX TRX Cloud.

Follow these steps for registering with CCX TRX Cloud:

1. Put the T-RX IP address in the browser as a URL to go to the T-RX Web GUI
2. Login to the T-RX Web GUI using credentials:
  - a. user: admin
  - b. password: admin
3. Then navigate to SystemX -> Register with Server -> New Request. Set the Key Manager Server Address to the IP of the server (trx.ccx.cloud) and save it.
4. Click "Submit for Approval".
5. Contact CCX Technologies at [trx\\_support@ccxtechnologies.com](mailto:trx_support@ccxtechnologies.com) to get approval for registering with the server. Once approval is confirmed by a CCX technician, select "Register with Server (requires approval)".
6. A CCX Technologies technician will now be able to assist you by accessing your T-RX remotely.

The screenshot displays the 'Register with Server' interface in the CCX Technologies web GUI. The top navigation bar includes the CCX logo and the user's role as 'SystemX Admin'. The left sidebar provides a 'MAIN MENU' with various system management options. The central content area is titled 'Register with Server' and is divided into three panels:

- Status:** Shows the current state of the registration request. It includes a green checkmark and the text 'Submitted for Approval' and 'Approved', indicating that the request has been successfully processed by the Key Manager Server.
- Configuration:** Contains several input fields for setting up the registration:
  - Request Name:** Client-1
  - Key Manager Server Address:** trx.ccx.cloud
  - Site Identification or Tail Number:** (Empty field)
  - ICAO Code:** (Empty field)
  - Contact Name:** (Empty field)
  - Contact Email:** (Empty field)
  - Contact Phone Number:** (Empty field)
- Utilities:** Provides actions for the registration request, including a 'Submit for Approval' button, a 'Register with Server (requires approval)' button, and a 'Delete' button.

## License Code Activation Process

A T-RX™ with License Group 'Radio', 'Pulse', or 'Radio Pulse Plus' will not need license activation unless an additional test (such as GPS) is added.

1. Power unit on and wait for unit initialization to complete (~1min)
2. Press the "SETTINGS" menu and select the option "ABOUT"

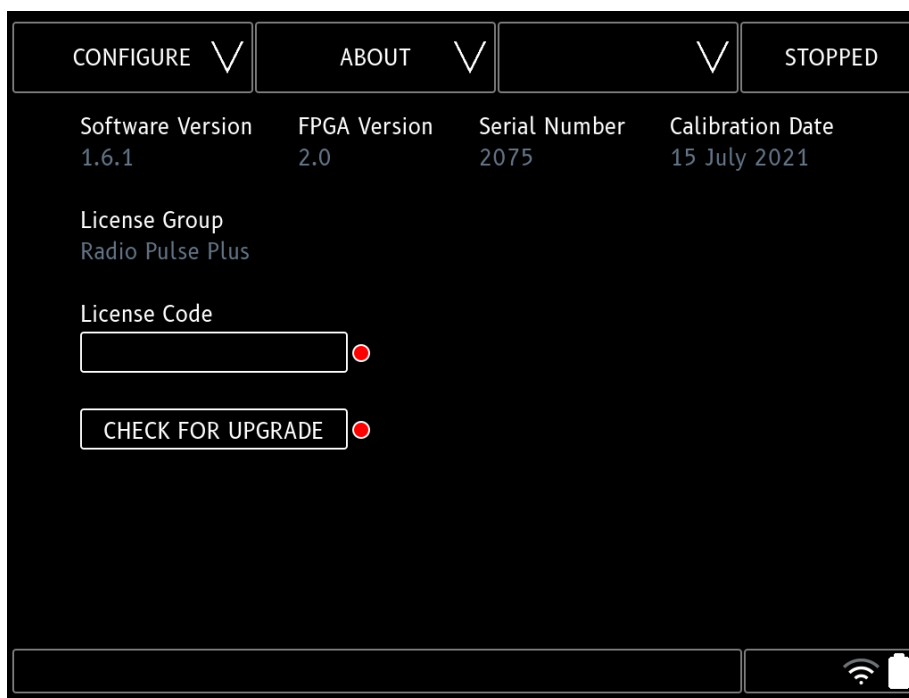

Fig. 1: T-RX "ABOUT" screen

3. Press the "License Code" field box
4. Enter the LICENSE CODE as received from CCX Technologies using the alphanumeric keyboard
5. Press the verify button after the license code has been entered in full
6. If the license code is valid, the license code indicator will change from red to green. If the license code is invalid, the license code indicator will remain red
7. Restart the unit using the power button or software restart and wait for the unit to initialize

8. The desired license will be shown in the License Group.

**NOTE:** Individual licenses such as GPS will not be shown in the License Group, but will be shown in the Test menu.

## FAQ

**Q.** Will my T-RX™ battery be damaged if the external charger remains connected once the battery has fully charged?

**A.** No. The Li-ion smart battery will not be damaged. It is safe to leave the charger connected.

**Q.** Can I upgrade my T-RX™ software in the field?

**A.** Yes. T-RX™ software upgrades can be performed in the field. Contact CCX Technologies at [t-rx\\_support@ccxtechnologies.com](mailto:t-rx_support@ccxtechnologies.com) for information on the latest software.

**Q.** Can I upgrade my T-RX™ Radio or T-RX™ Pulse?

**A.** Yes! Add-ons can be purchased and added to your T-RX™ in order to support your specific needs.

**Q.** Is calibration required for my T-RX™?

**A.** The T-RX™ ships fully calibrated but should be calibrated annually. Contact CCX Technologies to inquire about our annual calibration service.

## Contact Us

Should you need any further assistance, contact us either by email or phone.

Refer to your warranty certificate to find the expiry date of the warranty.

Refer to the calibration certificate, the on screen calibration date during boot up, or the About/System page to determine calibration date.

Tech Support: [t-rx\\_support@ccxtechnologies.com](mailto:t-rx_support@ccxtechnologies.com)

Calibration: [calibration@ccxtechnologies.com](mailto:calibration@ccxtechnologies.com)

Phone: +1 (613) 695-9434