

**OB-30 OXYGEN BOOSTER
INSTALLATION, OPERATION
& MAINTENANCE MANUAL**



INTERFACE DEVICES, INC. 230 Depot Road, Milford, CT 06460
Ph: (203) 878-4648, Fax: (203) 882-0885, E-mail: info@interfacedevices.com

www.interfacedevices.com

**IMPORTANT! FILE THIS MANUAL IN A SAFE PLACE FOR FUTURE SERVICE & PARTS NEEDS
ALWAYS REFERENCE THE SERIAL NUMBER FOR SERVICE & PARTS REQUESTS**

Safety instructions specifically pertaining to this unit appear throughout this manual:

Warning: denotes practices, which if not carefully followed, could result in property damage, **SERIOUS** personal injury and /or **DEATH**

**IN ADDITION TO READING THIS MANUAL, IT SHOULD BE MANDATORY FOR ALL
USERS TO VIEW THE OB-30 TRAINING VIDEO AT:**

OB30training.com

OB-30 Serial Number: _____

This manual covers specifications and information for models dating from 2005 and the latest design model from 2013. Please take note of the items pertinent to the model vintage being used.

Save the original packaging in which the OB-30 was received to be used for returning the unit for recertification.

Note “oxygen” & the chemical symbol “O₂” are used interchangeably throughout this manual.

INTERFACE DEVICES, INC.
OB-30 OXYGEN BOOSTER

STATEMENT OF WARRANTY

INTERFACE DEVICES, INC. (hereafter, the factory) warrants its products to be free from defects in material and workmanship under normal use and service for a period of one (1) year from date of shipment from the factory. Any defect discovered after the warranty period has expired will be deemed to be outside the above coverage. No goods claimed to be under warranty shall be accepted for return unless authorized by the factory beforehand.

Upon discovery of a defect (other than freight damage) or a shortage of an item received in the original factory container, the purchaser shall, within (10) calendar days, deliver notice of the defect or shortage. Damaged freight claims must be placed with the freight carrier and will not be honored by the factory. If, after due investigation of a claim of defect or for shortages is found valid, the factory, at its sole discretion, may discharge its entire obligations to the purchaser by either repair or replacement of the defective product or component and for shortages by furnishing a replacement of the missing quantity (FOB, factory).

This express warranty supersedes and is in lieu of all other remedies and warranties, including the implied warranties of merchantability and fitness for a particular purpose, and liability for negligence.

IN NO EVENT SHALL THE FACTORY BE LIABLE TO THE CUSTOMER OR ANY OTHER PERSON OR ORGANIZATION FOR ANY INDIRECT, INCIDENTAL, CONSEQUENTIAL, SPECIAL, OR EXEMPLARY LOSSES, EXPENSES, OR DAMAGES ARISING OUT OF OR RELATED TO ITS PRODUCTS, INCLUDING WITHOUT LIMITATION, ANY DAMAGES FOR DIMINUTION OF MARKET VALUE, LOSS OF USE, LOSS OF PROFITS OR OTHER FINANCIAL OR ECONOMIC LOSS, OR FOR ANY INTERRUPTION IN CUSTOMER'S BUSINESS OCCASIONED BY ITS INABILITY TO USE THE PRODUCTS FOR ANY REASON WHATSOEVER, EVEN IF THE CUSTOMER HAS BEEN ADVISED OF THE POSSIBILITY OF SUCH DAMAGES OR LOSSES. THE FACTORY SHALL NOT BE LIABLE FOR ANY DAMAGES CLAIMED BY THE CUSTOMER OR ANY OTHER PERSON OR ENTITY WHETHER BASED ON CONTRACT OR IN TORT.

****WARNING****

There is an inherent risk associated with pressurized oxygen systems. Failure to follow the manual's instructions or other safety procedures increases the risk of an ignition source being introduced into the oxygen flow stream that could result in a fire, explosion, property damage, serious personal injury or death. In addition to following the OB-30 manual instructions, remember to take appropriate safety measures with all components in the oxygen system. In no event shall Interface Devices, Inc. be held liable for any property damage, injury or death in the event the OB-30 booster is NOT installed, operated or maintained in strict accordance with this manual and other published oxygen service guidelines.

INTERFACE DEVICES, INC.
OB-30 OXYGEN BOOSTER

Table of Contents

1.0	General Description.....	4
2.0	Specifications / Features	6
2.1	High Pressure Oxygen Booster	
	Component Description.....	6
	Non-Booster Component Pictures.....	7
3.0	Preparation for use.....	8
3.1	Safety Instructions.....	8
3.2	General Safety Instructions.....	8
3.3	Installation	10
4.0	Operation	11
4.1	Preparation for Operation.....	11
4.2	Charging The Aircraft Oxygen System.....	11
4.3	Disconnecting from Aircraft.....	12
5.0	Maintenance.....	12
5.1	Precautions & Procedures	13
5.2	Preventative Maintenance Schedule.....	13
5.3	Spool Lubrication Guideline	14
5.4	Storage	14
5.5	Recertification.....	15
6.0	Oxygen System Specification Information	16
7.0	Trouble Shooting.....	17
8.0	Table 1 – Temperature Correction.....	18
	Drawings	19-28
	Appendix A (Coalescing Filter)	29
	Appendix B (Excess Flow Valve).....	36

INTERFACE DEVICES, INC.
OB-30 OXYGEN BOOSTER

1.0 General Description

- 80 psi drive pressure produces 2,200 psi oxygen pressure
- Shop air or nitrogen powered for use in and around the hanger



Designed for Safety:

- Oxygen wetted components are principally brass – one of the best materials for oxygen service surpassing materials such as stainless steel for ignition resistance in a pure oxygen environment
- All oxygen wetted parts have been cleaned per Spec. ARP 1176
- Other materials are optimized for oxygen service including a Monel™ shaft for 2013 models and in 2005 model recertified units

Features:

- No inlet valve. Air regulator or lubricator required
- A coalescing drive filter is supplied and should be installed as near as possible to the drive inlet
- Dual 10 micron filters are included for the oxygen in and oxygen out ports
- Integral cut-in and cut-out pressure switches. Pump will not run if oxygen inlet pressure is below 250 psi or oxygen outlet pressure is above 2,400 psi
- Polymeric seals and bearings for long life and high efficiency
- Sparkless operation
- To preclude drive supply from contaminating oxygen, twin rod seals are supplied with a vent to atmosphere that minimizes the likelihood of drive media/oxygen migration
- Integral air regulator with pump on/off air toggle switch
- May be nitrogen-powered for remote operation
- Excessive flow shut-off valve is supplied loose to mitigate risk/damage in the unlikely event of an ignition incident or opening of the oxygen bottle too quickly. This valve is supplied with newer models, available for retrofit for older models or units returned for recertification

INTERFACE DEVICES, INC.
OB-30 OXYGEN BOOSTER

**** Warning ****

To Avoid Serious Injury, Property Damage or Death

1. **Never** operate the OB-30 unattended
2. **Always** have a properly rated and charged fire extinguisher close at hand
3. **Routinely check the drive filter and replace the element in accordance with recommended maintenance practices. (See paragraph 3.2.4 and Appendix A).**
4. **Do not** use on **LOW PRESSURE** aircraft systems.
This is an **UNREGULATED OXYGEN SOURCE** equal to supply bottle pressure.
The use of a supply bottle pressure regulator is required with this unit.
5. **Do not** use to boost air or any gas other than oxygen.
6. **Do not** exceed 2,200 PSIG inlet pressure.
7. All components used in the oxygen system shall be clean, dry and free of all contamination per specification SAE ARP1176.
8. Servicing and/or maintenance of oxygen systems shall be done by trained and qualified personnel using approved procedures.
9. All components in conjunction with the OB-30 booster shall comply with NFPA – 53 “Recommended Practice on Materials, Equipment, and Systems Used in Oxygen-Enriched Atmospheres” - 2011 Edition and SAE Spec. ARP 1532, “Aircraft Oxygen System Lines, Fabrication, Test and Installation.”

INTERFACE DEVICES, INC.
OB-30 OXYGEN BOOSTER

2.0 Specifications / Features

Dimensions: 14" long (2005)/15" long (2013), 9.4" high and 8.9" wide.

Weight: 42 lbs (2005)/ 45 lbs (2013) complete.

Input & output hoses required: stainless steel/Teflon® -4 JIC rated to 3,000 psi.

Booster output rating = 2,200 psig.

Oxygen booster ratio: 30:1.

2.1 Component Description (Refer to Fig. 1a. for component location.)

1. Air or nitrogen inlet port (1/2 NPT).
2. Air regulator & gauge.
3. Booster On/Off air toggle switch.
4. Oxygen out port -4 JIC fitting 2,200 psig max.
5. Oxygen in port -4 JIC fitting 2,200 psig max.
6. Oxygen in (supercharge) pressure gauge.
7. Oxygen out pressure gauge.
8. Cut in/cut out pressure switches (factory preset).
9. Air vent filter.
10. Coalescing inlet filter, shipped loose. See Appendix A.
11. Excessive flow shut off valve, shipped loose. See Appendix B. Not included with 2005 models but available for models returned for recertification or as a retrofit.
12. Drive pressure relief valve.

Figure 1a.

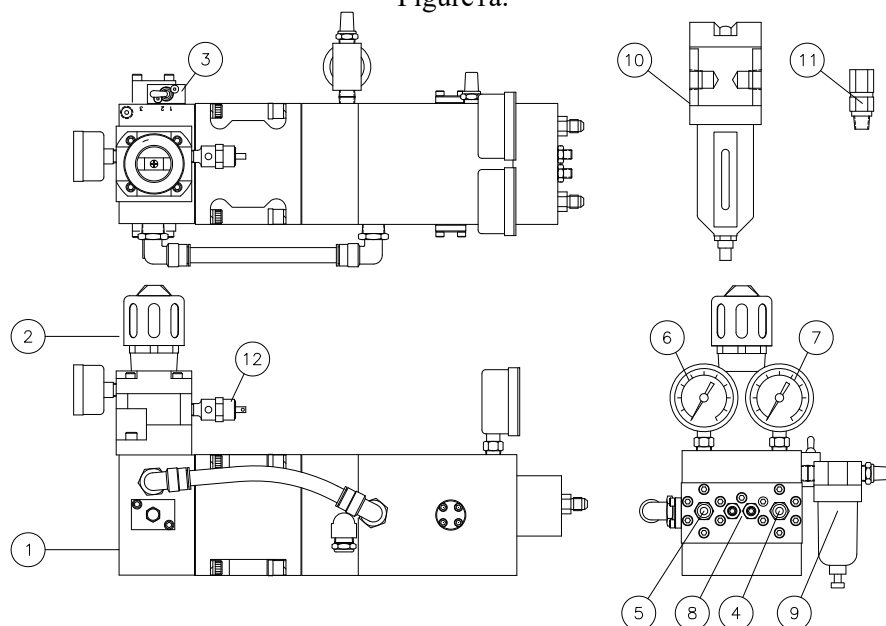

INTERFACE DEVICES, INC.
OB-30 OXYGEN BOOSTER

Coalescing Inlet Filter



ID/Date Label for Coalescing Filter.
To be Applied Prior to Installation

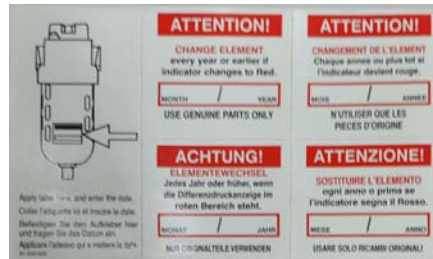

Excessive Flow Valve (Included with 2013 Models.
Factory Recommended for Retrofit on 2005 Models)



INTERFACE DEVICES, INC.
OB-30 OXYGEN BOOSTER

3.0 The OB-30 Preparation for Use

**** Warning ****

It is mandatory that this instruction manual be read, understood and followed by all persons operating this high-pressure oxygen booster.

3.1 Safety Instructions

- 3.1.1 Information presented in this manual and on various labels, tags and plates on the unit plus other system components pertains to equipment design, installation, operation, maintenance and troubleshooting which must be read, understood and followed for safe and effective use of this equipment. Also, refer to the OB-30 Training Video at <http://OB30training.com>.
- 3.1.2 The operation, maintenance, and trouble shooting of the OB-30 oxygen booster require practices and procedures that ensure personal operator safety and the safety of others. Therefore, this equipment is to be operated and maintained only by qualified persons in accordance with this manual and all applicable local codes.
- 3.1.3 Any air compressor used to drive the booster must only supply clean, dry and filtered air. The OB-30 comes with a coalescing filter that reduces the risk of water or compressor oil being introduced to the booster, but a separate filter and dryer should be installed at the exit of the compressor.

Safety instructions specifically pertaining to this unit appear throughout this manual highlighted by the signal word ****Warning**** to denote a potential hazard.

Warning: denotes practices, which if not carefully followed, could result in property damage, **SERIOUS** personal injury and /or **DEATH**

- 3.1.4 Read through this entire manual prior to oxygen booster operation. All personnel using the OB-30 booster must understand and follow this manual and be fully trained in handling pure oxygen under pressure. Users are encouraged to call Interface Devices, Inc. to discuss any operating or testing requirements. All operators of the OB-30 must be familiar with high-pressure oxygen service per the NFPA-53 publication: "Oxygen System Recommended Practices and Materials" and SAE Specification ARP 1532

3.2 General Safety Precautions

INTERFACE DEVICES, INC.
OB-30 OXYGEN BOOSTER

- 3.2.1 Gasses under pressure are a potential hazard in the form of stored energy. Accidents can occur when this energy is improperly handled. Be sure that all equipment used is compatible and designed to control the pressures encountered.
- 3.2.2 Oxygen flowing at a high velocity in a system can propel particles with such force that the impact friction can raise the particles temperature to a possible ignition point. It is therefore imperative that the components in the oxygen system be cleaned per SAE ARP1176 or equivalent specification at all times and instructions for initializing oxygen flow be closely followed. An excessive oxygen flow valve is available that will stop the flow of oxygen when above safe conditions. In the event the valve stops the O₂ flow, depressurize the entire system to reset the valve and begin safe operation with less flow.

**** Warning ****

High oxygen concentrations can accelerate the combustion of flammable materials up to and including explosion. Familiarity with the excessive flow valve mounted to the bottle for proper operation and maintenance is imperative.

- 3.2.3 Oxygen is a gas that promotes combustion; especially at high pressures. It is chemically stable, and non-flammable but will, combined with other elements support combustion especially at elevated pressures.

**** Warning ****

High oxygen concentrations can accelerate the combustion of most materials including most metals up to and including explosion or serious fire.

It is important to understand that combustion of materials such as oil can occur in oxygen rich atmospheres resulting in ignition of materials including metals such as stainless steel.

- 3.2.4 The coalescing inlet filter and the vent filter need to be inspected prior to each use. The coalescing filter element must be changed when the red indicator on the filter is on, contaminants are suspected to be present or at least once per year, whichever occurs first. The vent filter must be changed annually or immediately if contamination is present or even if the filter is thought to have been compromised.
- 3.2.5 The use of oxygen approved lubrication in an oxygen system should be kept to a minimum. The OB-30 requires regular lubrication of the air spool with Christo-Lube MCG-111 certified for oxygen environments. An air line lubricator is **not** to be used. No lubricant shall be applied in any area that will come into direct contact with oxygen during normal use.

**** Warning ****

Hydrocarbon based lubricants cannot be used. Only lubricants compatible with high pressure oxygen systems shall be used. Only oxygen approved lubricants such as Christo-Lube MCG-111 can be used

INTERFACE DEVICES, INC.
OB-30 OXYGEN BOOSTER

3.3 Installation

- 3.3.1 Although the oxygen booster is inspected prior to shipping, it could be damaged during shipping. Therefore, it should be carefully unpacked and placed on a clean level surface for inspection.
- 3.3.2 The OB-30 booster is shipped with special, high strength packaging. This packaging needs to be saved for future use such as when returned for recertification.
- 3.3.3 The bottom of the booster is furnished with three ¼-20 by ½” deep tapped holes for mounting to a bracket or cart.
- 3.3.4 Customer installed parts (oxygen components must be in accordance with NFPA-53).
- a. Two stainless steel/PTFE -4 hoses rated to 3,000 psi working pressure
 - b. Aircraft pressurization attachment fitting
 - c. Coalescing inlet air filter rated to 125 psi at 40 SCFM (shipped loose)
 - d. 2013 models include an excessive flow valve (shipped loose)
 - e. 2005 models should be retrofitted with an excess flow valve cleaned and approved for oxygen service from the factory or other source
 - f. Oxygen shut-off valve (mounted away from the booster)
- 3.3.5 Install the coalescing filter as near as possible to the booster inlet.
- 3.3.6 Install the excessive flow valve immediately after the regulator on the oxygen bottle.
- 3.3.7 Remove protective caps from “O₂ IN” and “O₂ OUT” fittings.
- 3.3.8 With oxygen supply regulator closed, connect both -4 hoses to the oxygen in and out fittings on the booster.

**** Warning ****

The customer supplied oxygen supply must be complete with shutoff valves, pressure gauges, pressure regulators and Stratoflex® -4 hose. All components must be rated for 3,000 psi working pressure, cleaned for oxygen service and conform to NFPA-53 guidelines

- 3.3.9 Attach aircraft pressurization fitting to the far end of the -4 hose coming from the oxygen out hose.
- 3.3.10 Check all components for integrity and contamination. If all is well and thoroughly checked to be in compliance, the OB-30 is ready for use.

**** Warning ****

Always inspect unit before use. Damaged, contaminated or oily equipment must never be used.

INTERFACE DEVICES, INC.
OB-30 OXYGEN BOOSTER

4.0 Operation

4.1 Preparation for Operation

- 4.1.1 Be sure all valves and controls are in the closed or “failsafe” position.
- 4.1.2 Decrease item 2 (figure 1a, page 6) inlet pressure regulator to minimum pressure setting.
- 4.1.3 Inspect all connections for contaminants before installation and tightening. Inspect and replace any suspect components. Be sure all oxygen components are clean per SAE specifications and comply with NFPA-53 publication: “Oxygen System Recommended Practices and Materials” and SAE Specification ARP 1532.
- 4.1.4 Connect the output of the gas supply bottle to the gas inlet connection of the oxygen booster (See figure 1a, page 6).
- 4.1.5 Decrease the gas supply bottle or shop supply air/gas regulator to the minimum pressure setting.
- 4.1.6 Connect the O₂ fill line loosely to the aircraft and purge line by SLOWLY cracking open gas supply bottle shutoff valve and adjusting the supply bottle pressure to a low flow setting.

**** Warning ****

Be sure fill line is secured prior to purging the unit. This will prevent the hose from whipping about if too much O₂ is allowed to flow through the unit.

- 4.1.7 Tighten the O₂ fill line connection at the aircraft.
- 4.1.8 The OB-30 booster is ready to charge an aircraft O₂ System.

4.2 Charging the Aircraft Oxygen System

- 4.2.1 After the oxygen booster has been properly connected, **slowly** open the O₂ supply bottle shut on/off valve. Adjust the gas supply bottle pressure regulator to the required aircraft O₂ system pressure. Wait until the bottle pressure and the aircraft system pressure are equal. If the flow of oxygen ceases, the flow valve has probably been triggered. Depressurize the system to reset the valve and reopen the oxygen supply at a lower flow.
- 4.2.2 **Note: If the bottle pressure is lower than the required aircraft oxygen system pressure, be careful not to over adjust the supply bottle pressure regulator once the maximum**

INTERFACE DEVICES, INC.
OB-30 OXYGEN BOOSTER

supply bottle pressure has been achieved. Increasing the oxygen pressure regulator beyond this point will not increase output, and may damage the regulator spring.

- 4.2.3 Adjust the booster's air pressure regulator to attain a pressure slightly lower than the final required O₂ pressure (divide this oxygen pressure by 30 to find the initially required regulated air pressure setting). Example: 2,200 psi final pressure minus 100 psi equals 2,100 psi, divided by 30 equals 70 psi regulated air pressure.

Note: If the ambient temperature at the time of oxygen system recharging is above or below 70 degrees Fahrenheit, refer to Table 1 to determine the correct final pressure.

- 4.2.4 Turn on the booster's "pump run" toggle switch to "on" to further pressurize aircraft oxygen system. Note: Because the oxygen booster pump operates at a theoretical ratio, actual boosted oxygen pressures may vary slightly due to different physical conditions. The oxygen outlet pressure gauge will show the aircraft system pressure developed by the oxygen booster. When the set pressure that has been achieved (i.e.: booster stops pumping), increase the pressure of the air regulator to obtain the required final aircraft system pressure. Turn off the booster's air toggle switch when the booster has stopped running.

4.3 Disconnecting the Oxygen Booster from the Aircraft

- 4.3.1 Close the oxygen bottle shut off valve.
- 4.3.2 Decrease both the air inlet pressure regulator and the oxygen supply bottle pressure regulator to their respective minimum settings.
- 4.3.3 Disconnect booster's air (or nitrogen) supply line.
- 4.3.4 Slowly loosen, bleed down, and disconnect oxygen hose at the aircraft. Disconnect the O₂ supply hose from the bottle
- 4.3.5 Cap both all exposed hose connections to prevent contamination.

5.0 Maintenance

**** Warning ****

Maintenance must be undertaken by qualified personnel only.

The operation, maintenance and troubleshooting of the oxygen booster system requires practices and procedures which ensure personal operator safety and the safety of others. Therefore, this equipment is to be operated and maintained only by qualified persons in accordance with this manual and all applicable codes.

INTERFACE DEVICES, INC.
OB-30 OXYGEN BOOSTER

5.1 Precautions and Procedures

- 5.1.1 All maintenance performed on the OB-30 oxygen booster shall be conducted in accordance with all applicable codes governing the handling, operation, installation and trouble shooting for high-pressure O₂ operation. Maintenance is to only be done by qualified persons.
- 5.1.2 All personnel must be familiar with the warnings associated with high-pressure O₂ systems as outlined in sections 3.1 and 3.2 of this manual prior to performing any maintenance on this unit.
- 5.1.3 The oxygen pressure gauges on this unit are supplied for reference purposes. Calibrated and certified gauges should be used for determining final pressure to the aircraft, which are available from the factory at time of purchase or upon request during recertification.

5.2 Preventative Maintenance Schedule

Item	Usage Task	Action Required
General	Inspect all components prior to every use for contaminants or damaged/suspect components	Return the booster for recertification if the booster or other components have been suspected to have been compromised or after 1500 hours of operation or after 2 years, whichever comes first
Reciprocating Circuit (See paragraph 5.3.1 below for instructions)	Ensure the drive section and reciprocation circuit are clean and lubricated with oxygen approved Christo-Lube MCG-111	Lubricate the spool section every 6 months using <u>ONLY</u> lubricant approved for oxygen service such as Christo-Lube MCG-111
Vent Filter	Inspect prior to every use to ensure cleanliness	Replace the vent filter annually or immediately if it appears to be contaminated
Coalescing Drive Filter	Inspect prior to every use to ensure cleanliness. Verify the filter indicator is green and not red	Replace the filter element annually, when the filter indicator turns red or immediately if it appears to be contaminated
Other System Components	Inspect prior to every use to check for contaminants and ensure cleanliness	Replace any component that may have been compromised in any way. Consult the manufacturer of the component for additional instructions
The exterior of the OB-30 is dirty or contaminated in any way	Do not use the booster	Return for factory recertification

INTERFACE DEVICES, INC.
OB-30 OXYGEN BOOSTER

5.3 Spool Lubrication Guideline

- 5.3.1 Provided the booster is not due for recertification, this section offers tips on lubricating the spool. If the booster is beyond the two-year time frame for required certification or compromised in any way the booster must be returned for service and recertification. As part of this process, the factory will tend to spool section lubrication.

To lubricate the spool section of the booster, refer to drawing number P33-1003 or P33-1004 in this manual. Remove the 2 cap screws securing item 9, Retainer Cap and item 15, Spool Cap. Extract item 6, Spool by pushing it from the Retainer Cap end using your pinkie finger or a blunt, soft small diameter tool. CAREFULLY remove the Bushings, O-rings and all Cages and Tee Seals, items 4 and 5, one at a time. You may need a pick type tool, which should be made from a soft material such as brass.

Clean all the extracted parts with a parts cleanser approved for pure oxygen wetted components and wipe clean. Apply Christo-Lube MCG-111 synthetic oxygen approved lubricant to the spool, cages and tee seals. Snugly install the retainer cap and then, one part at a time, put the assembly back in the spool cavity including O-rings, Bushings, Tee Seals and Cages. Ensure the Spool is free to move. Install the Spool Cap and tighten the cap screws on both the Spool Cap and Retainer Cap.

Note: Oxygen compatible synthetic Christo Lube MCG-111 is available from the factory in 2 oz. tubes.

5.4 Storage

- 5.4.1 Store the unit away from any aircraft in a clean, dry and secure area when not in use. Be sure all hoses are capped and the unit is covered with a lint free covering for the duration of unit storage to ensure complete O₂ system cleanliness for future aircraft system recharging

INTERFACE DEVICES, INC.
OB-30 OXYGEN BOOSTER

5.5 Recertification

- 5.5.1 The OB-30 must be inspected prior to each use. If, after conducting the OB-30 inspection, it is believed it may have been compromised with suspect components or sub-optimal operational or maintenance practices it **must** be returned for a complete inspection, cleaning and recertification. Recertification is also required for any OB-30 that has been in service for 1500 hours or two years since its last factory certification, whichever occurs first. OB-30 boosters being returned for recertification can only be sent to:

Interface Devices, Inc.
230 Depot Rd.
Milford, CT 06460 USA

The OB-30 is heavy for its size, so purpose built packaging is used to ship the booster. **BE SURE TO SAVE THE ORIGINAL BOX/PACKAGING** as this was designed specifically to transport the OB-30 booster for return to IDI when recertification is required. Contact IDI prior to returning the booster to obtain a Return Merchandise Authorization (RMA). Be sure to have the OB-30 serial number. The company, contact name, phone number & e-mail address **MUST** be included with the booster being returned.



INTERFACE DEVICES, INC.
OB-30 OXYGEN BOOSTER

6.0 Oxygen System Specification Information

For more information about the specifics of the OB-30 booster, contact:

Interface Devices, Inc.
230 Depot Rd.
Milford, CT 06460 USA
Tel+1 203-878-4648

OB-30 Training Presentation: <http://ob30training.com>

For more information concerning specific SAE Aircraft Oxygen Equipment Specification, contact:

Society of Automotive Engineers
400 Commonwealth Drive
Warrendale , PA 15096-0001 USA
Tel: +1 724 776 4841

For more information concerning specific Oxygen System Recommended Practices and Materials contact:

National Fire Protection Association
1 Batterymarch Park
Quincy, MA 02169-7471 USA
Tel: +1 617 770-3000

INTERFACE DEVICES, INC.
OB-30 OXYGEN BOOSTER

7.0 Trouble Shooting

**** Warning ****

Troubleshooting can only be undertaken by qualified personnel trained in servicing oxygen equipment only.

Troubleshooting Chart

Symptom	Probable Cause	Remedy
Pump will not cycle (Only regulated oxygen Pressure at out put.)	No air supply to pump Pump regulator set too low Four way air reciprocating valve spool stuck at mid position	Look for and fix Increase setting Disconnect/ reconnect air supply (resets air spool to end position) If spool still sticks, manually push spool to far end with probe through hole in “spool stop cap”. If stuck or requires excessive force, disassemble air valve assembly. Inspect for contamination or mechanical bind. Repair or replace, lubricate seals with Christo-Lube MCG-111 lubricant or other oxygen approved lubricant. Refer to the OB-30 Exploded Assembly Drawing in this manual
Pump makes one cycle then stops	Faulty “2 way air valve” (Broken, leaks or contaminated)	Repair or replace
Pump cycles constantly when dead headed (discharge of the unit is plugged preventing output flow of oxygen)	External leak at pump or downstream high-pressure circuit Contaminated or stuck open check valve cartridge Internal leak in pump	Look for and correct Clean or replace Check all dynamic and static seals and gaskets
No O ₂ flow to booster from the bottle	Excessive flow valve has closed (where applicable)	Reset valve by depressurizing the entire system per manufacturer’s instructions.

For further assistance, call Interface Devices, Inc. at 203-878-4648.

INTERFACE DEVICES, INC.
OB-30 OXYGEN BOOSTER

8.0 Table 1

Temperature/Pressure Correction

At Temperature Degrees F	Fill to Working Pressure x Figure Below
110°	1.1000
105°	1.0875
100°	1.0750
95°	1.0625
90°	1.0500
85°	1.0375
80°	1.0250
75°	1.0125
70°	1.0000
65°	0.9875
60°	0.9750
55°	0.9625
50°	0.9500
45°	0.9375
40°	0.9250

Example: Ambient Temp. = 90° F, Working pressure is 1800 PSIG

$$\text{Charge Pressure} = 1800 \text{ PSIG} * 1.0500 = 1890 \text{ PSIG}$$

REV	DESCRIPTION	BY	DATE
A	ADDED EXCESS FLOW VALVE	WNI	3/14/13

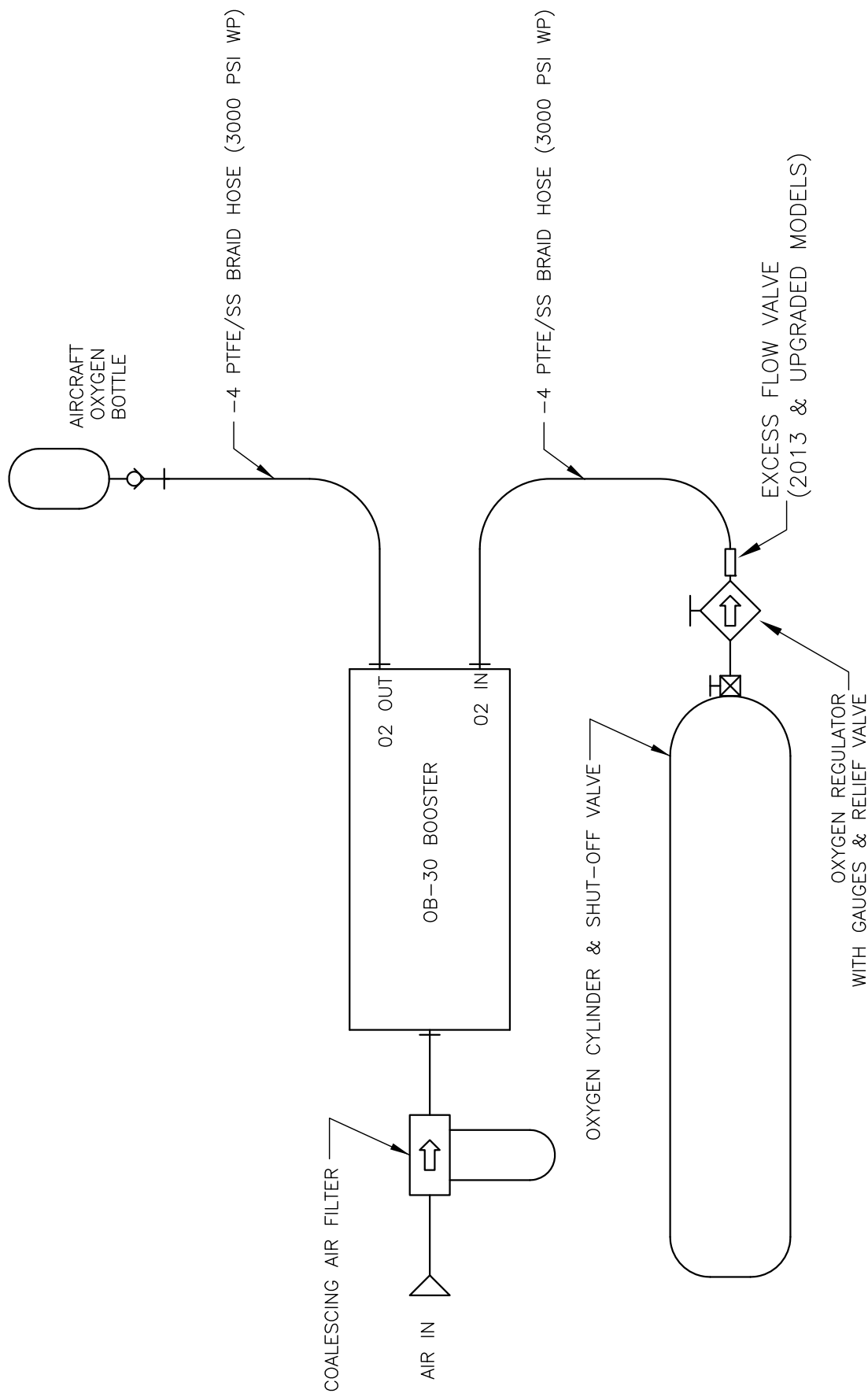

		INTERFACE DEVICES, INC. 230 DEPOT ROAD MILFORD, CT 06460	
SCALE: N/A	TITLE: BLOCK DIAGRAM, PNEUMATIC & OXYGEN SETUP		
DWN BY: TWH	REF:		
DATE: 3/31/05	DWG NO: BD-OB30		
SH: 1 OF: 1	REV: A		

REV	DESCRIPTION	BY	DATE
A	ADDED OPTIONAL COALESCING FILTER	WNI	9/29/06
B	FILTER RATING WAS 5u	WNI	2/21/07

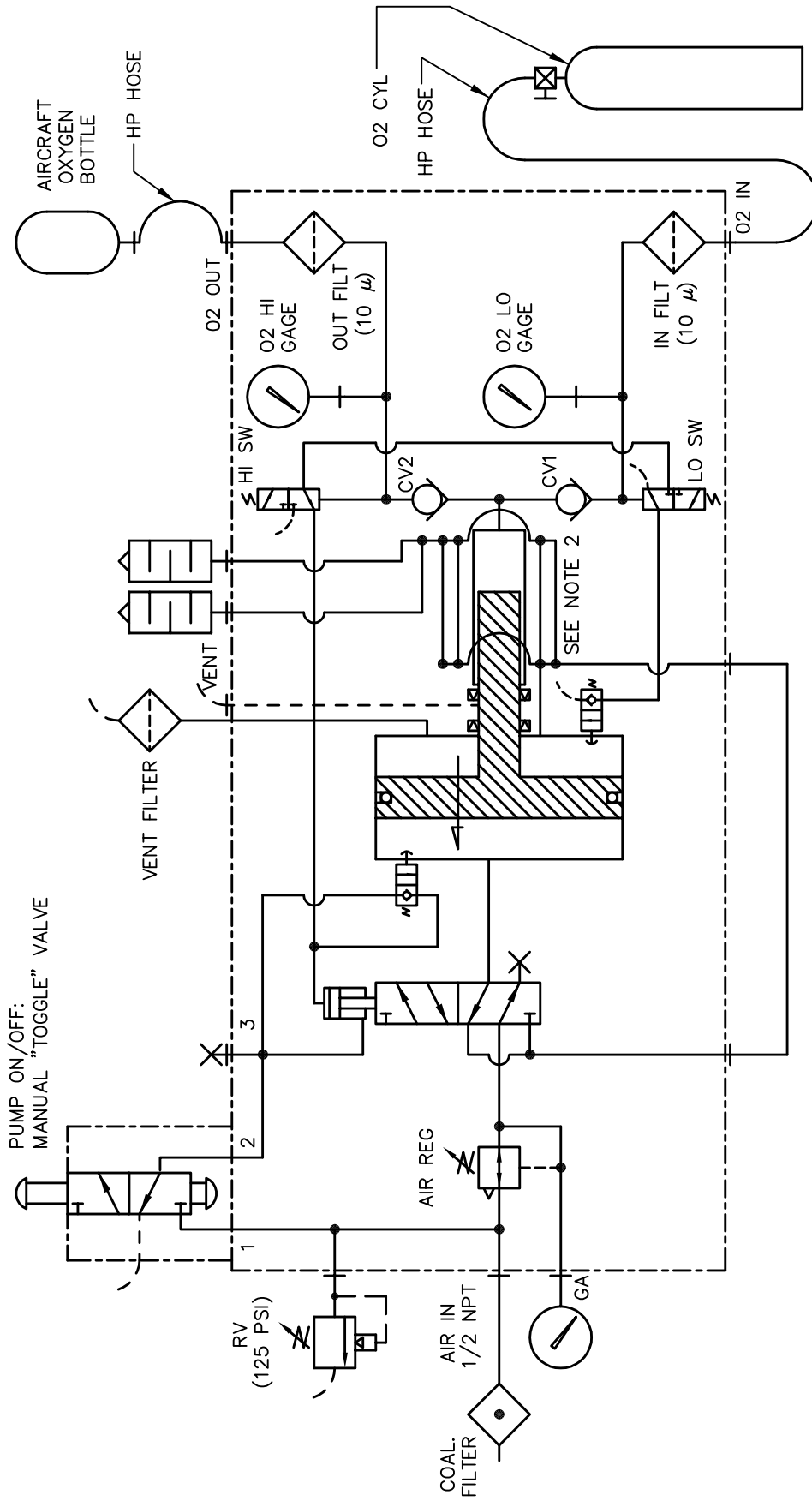

		INTERFACE DEVICES, INC. 230 DEPOT ROAD MILFORD, CT 06460
SCALE: FULL	TITLE: PNEUMATIC SCHEMATIC, 33:1 SA O2 BOOSTER	
DWN BY: TWH	REF:	
DATE: 3/14/01	DWG NO: P33-4002	
SHT: 1 OF: 1	REV: B	

- NOTES:
- "LO SW" OPENS ABOVE 250 PSI OXYGEN-IN PRESSURE (PUMP ON)
 - "HI SW" CLOSES ABOVE 2200 PSI OXYGEN-OUT PRESSURE (PUMP OFF)
 - COLD EXHAUST AIR IS ROUTED AROUND HI PRESSURE OXYGEN BORE FOR COOLING
- SOME COMPONENTS SHOWN ON THIS SCHEMATIC ARE OPTIONAL AND SPECIFIED SEPARATELY

REV	DESCRIPTION	BY	DATE
A	PICTURE CHANGE; ADDED SHEET 2	WNI	8/9/12

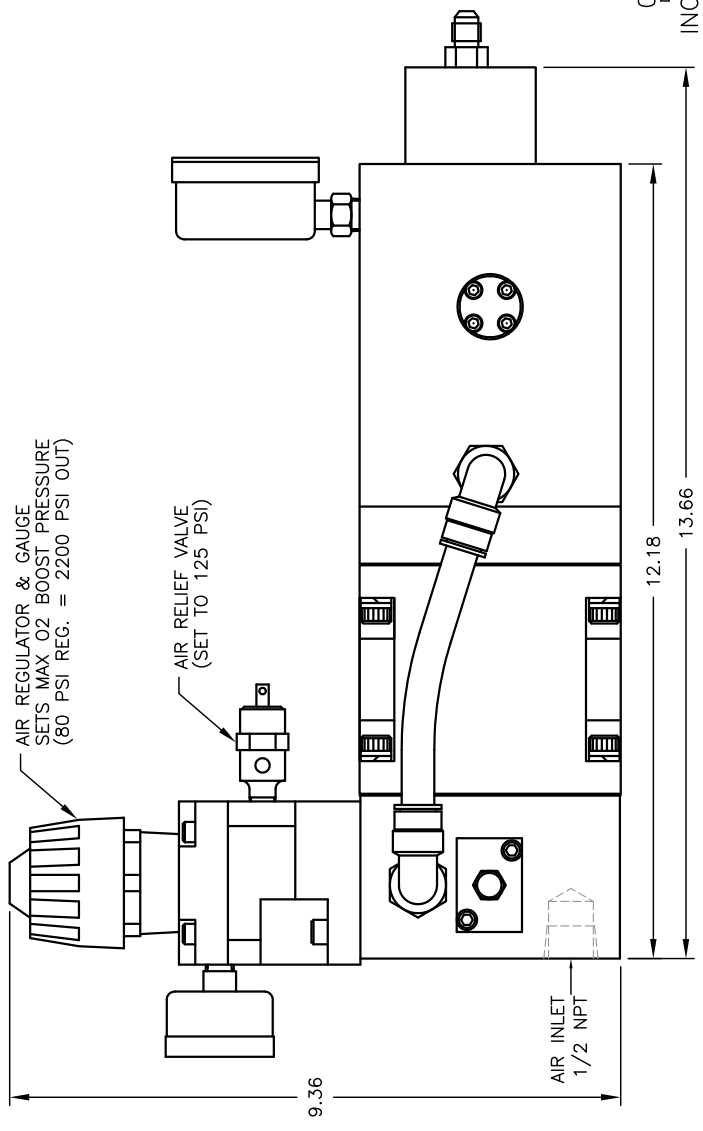
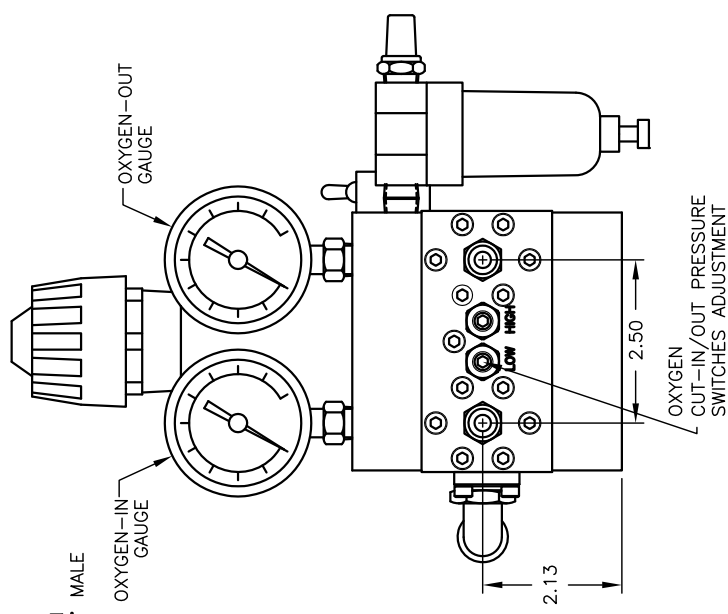
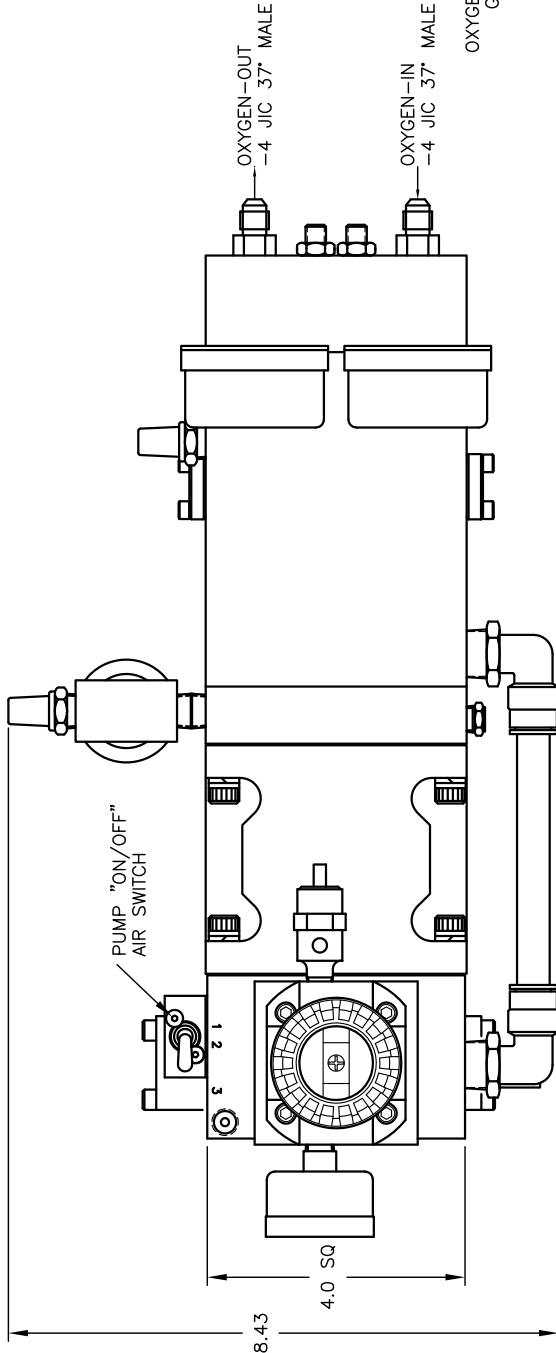

INTERFACE DEVICES, INC. 230 DEPOT ROAD MILFORD, CT 06460	
SCALE: HALF	TITLE: GENERAL ARRANGEMENT, OXYGEN BOOSTER
DWG BY: WNI	
DATE: 8/30/05	REF: 2005 Version
SHT. 1 OF 2	DWG NO: P33-0002
	REF: A



REV	DESCRIPTION	BY	DATE
A	PICTURE CHANGE; ADDED SHEET 2	WNI	8/8/12

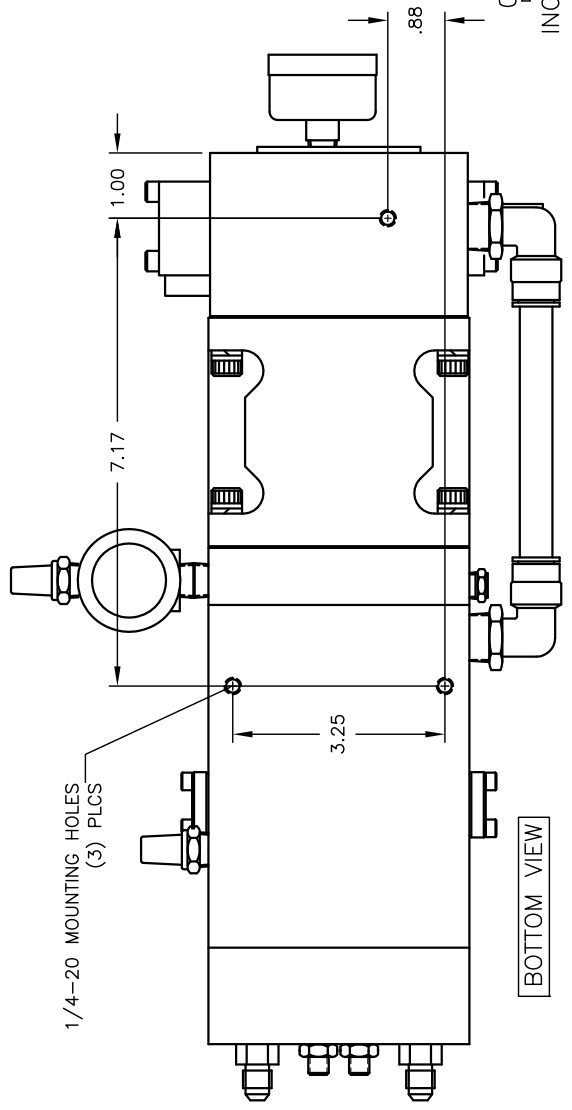
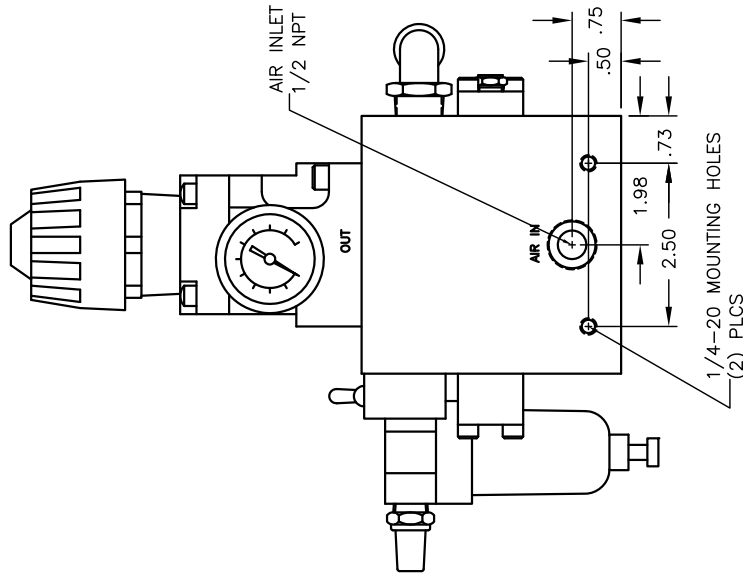
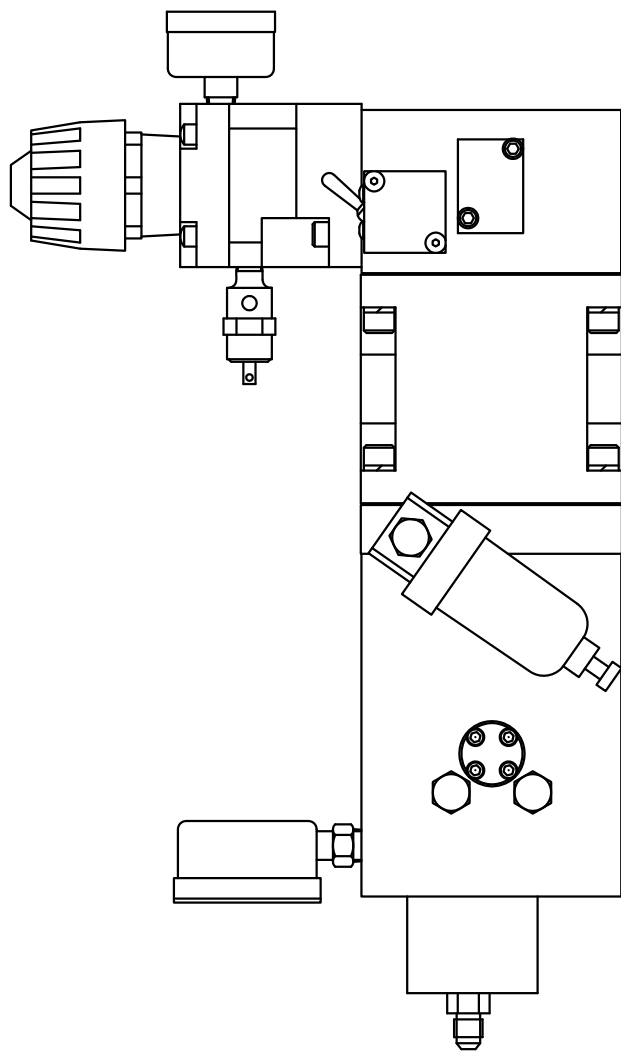

INTERFACE DEVICES, INC. 230 DEPOT ROAD MILFORD, CT 06460	
SCALE: HALF	TITLE: GENERAL ARRANGEMENT, OXYGEN BOOSTER
DWG BY: WNI	
DATE: 8/30/05	REF: 2005 Version
SHT. 2 OF 2	DWG NO: P-33-0002
	REF: A

REV	DESCRIPTION	BY	DATE
A	PICTURE CHANGE REGULATOR KNOB	WNI	9/19/19

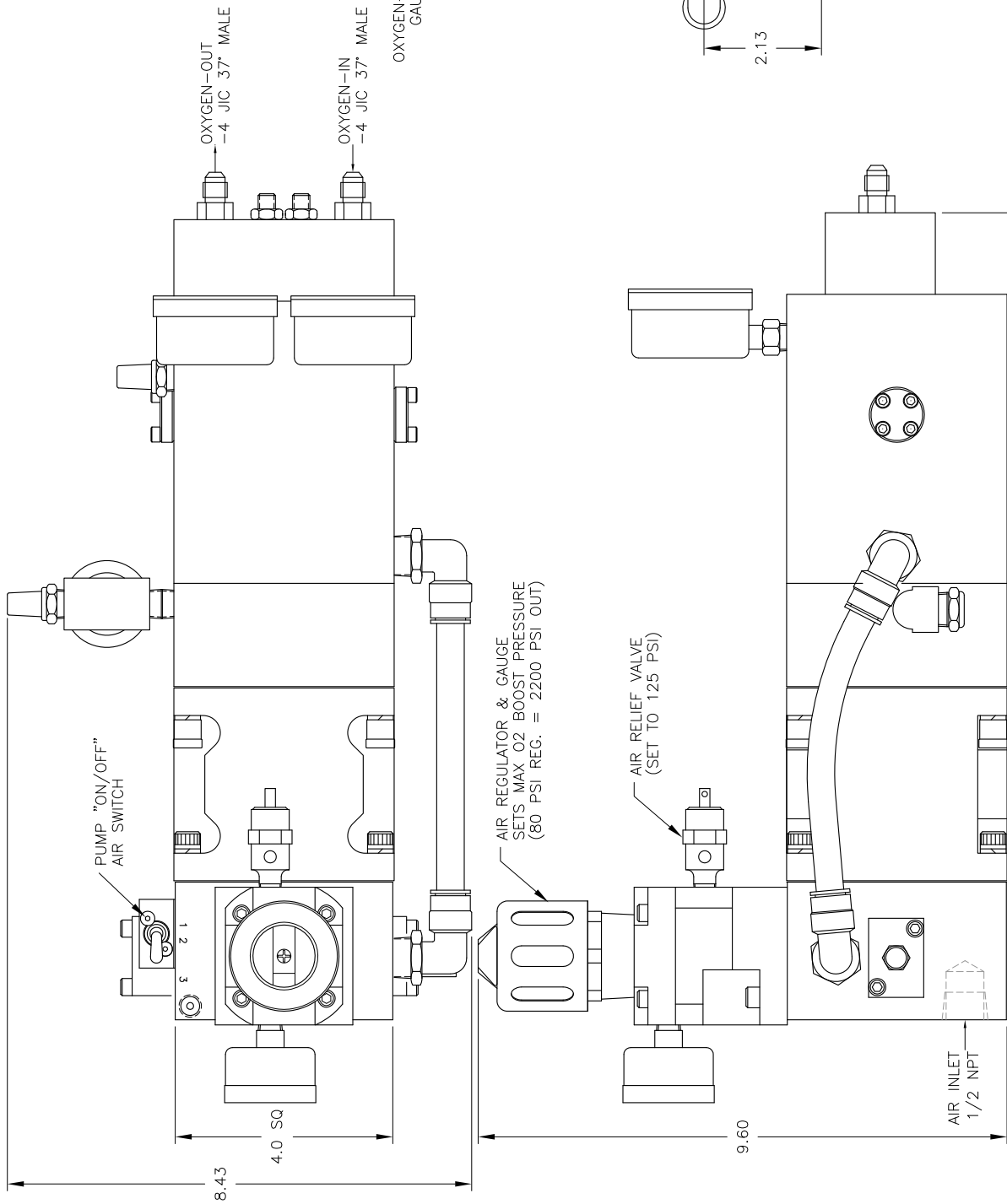

INTERFACE DEVICES, INC. 230 DEPOT ROAD MILFORD, CT 06460	
SCALE: HALF	TITLE: GENERAL ARRANGEMENT, OXYGEN BOOSTER
DWG BY: WNI	
DATE: 2/5/13	REF: 2013 Version
SHP: 1 OF: 2	DWG NO: P-33-0003
	REV: A

REV	DESCRIPTION	BY	DATE
A	PICTURE CHANGE REGULATOR KNOB	WNI	9/19/13

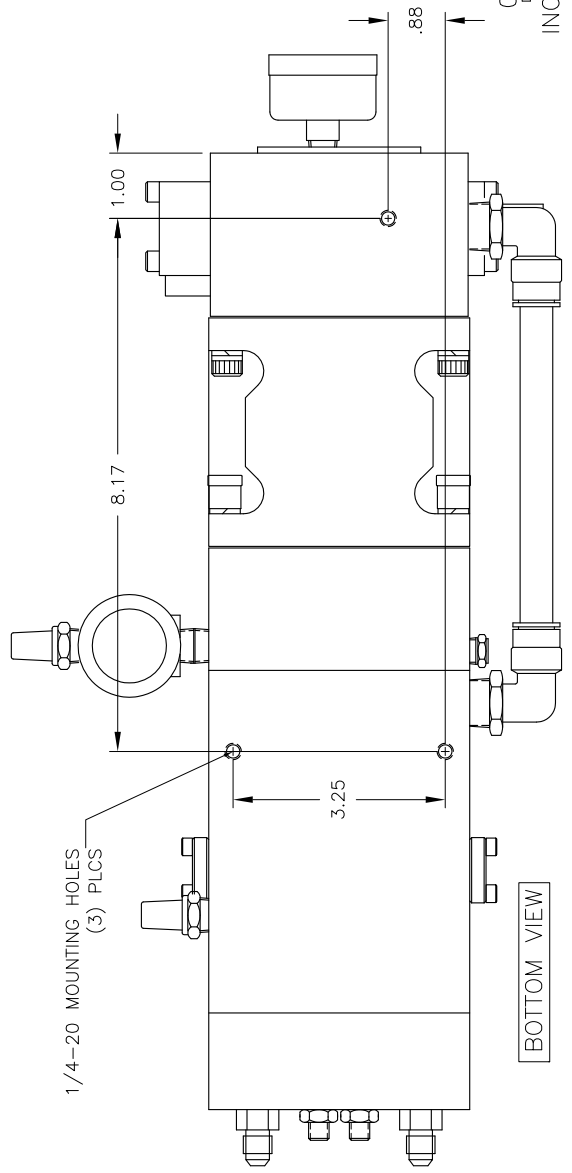
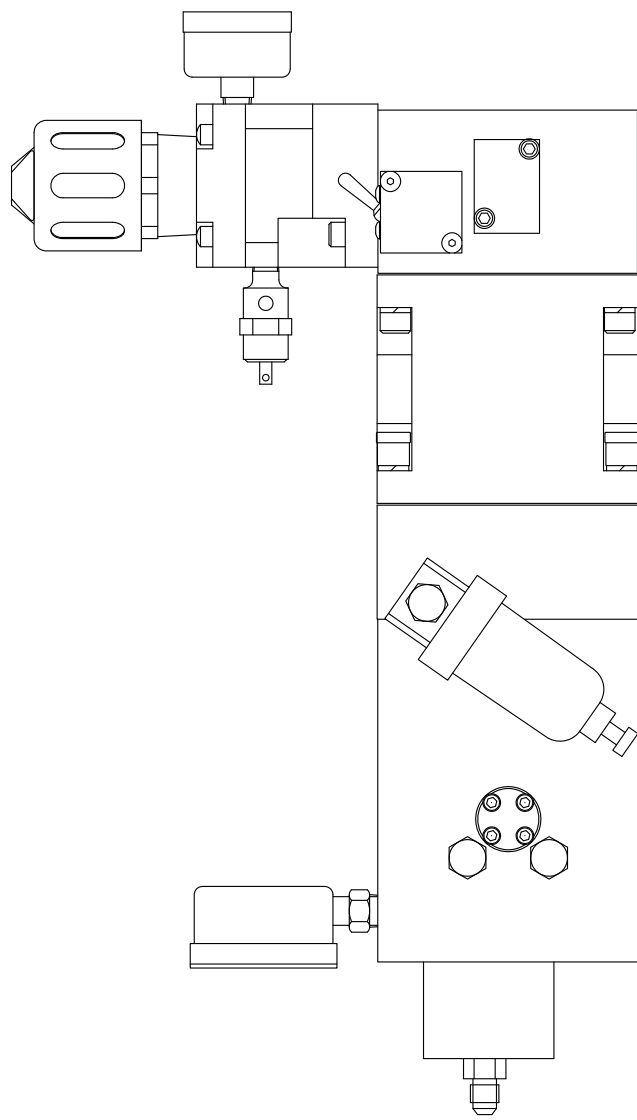
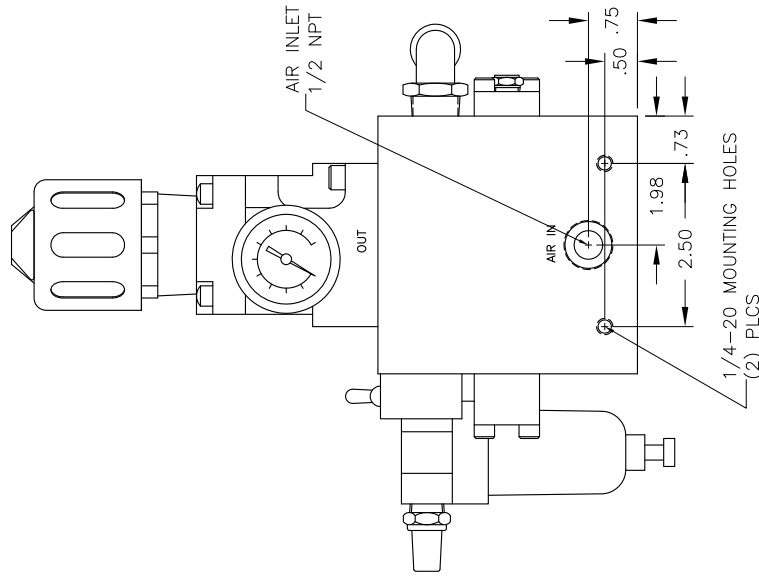

BOTTOM VIEW

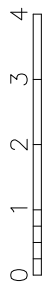

INCHES ON ORIGINAL DWG

INTERFACE DEVICES, INC. 230 DEPOT ROAD MILFORD, CT 06460	
SCALE: HALF	TITLE: GENERAL ARRANGEMENT, OXYGEN BOOSTER
DWG BY: WNI	
DATE: 2/5/13	REF: 2013 Version
SHT. 2 OF 2	DWG NO: P-33-0003
	REV: A

REV	DESCRIPTION	BY	DATE
A	28 WAS "WATERPROOF GREASE", PICTURE CHANGES; ADDED ITEM 93	WNI	10/11/05
B	ITEM 76 QTY WAS 2; ADDED ITEM 94	WNI	11/21/06
C	DELETED ITEM 91 (11633); ITEM 90 MAT. WAS VITON, NOW PTFE	WNI	12/31/09
D	DELETED 32 & 34. (INCLUDED WITH ITEM 31)	WNI	4/13/11
E	ADD CHART, ITM 26; DEL 42 & 77	WNI	11/12/12

- NOTES:
- 1 RECOMMENDED SPARES ITEM: SEAL KIT
 - 2 RECOMMENDED SPARES ITEM: OTHER
 - 3 LIGHTLY APPLY ITEM 28 "GREASE" TO ALL SEALS AND MATING PARTS AT ASSEMBLY
 - 4 WARNING: SOME COMPONENTS ARE ASSEMBLED IN A "CLEAN" ROOM. DISASSEMBLY BEYOND WHAT IS SHOWN ON THIS SHEET WILL CONTAMINATE THE PUMP AND VOID ALL WARRANTIES

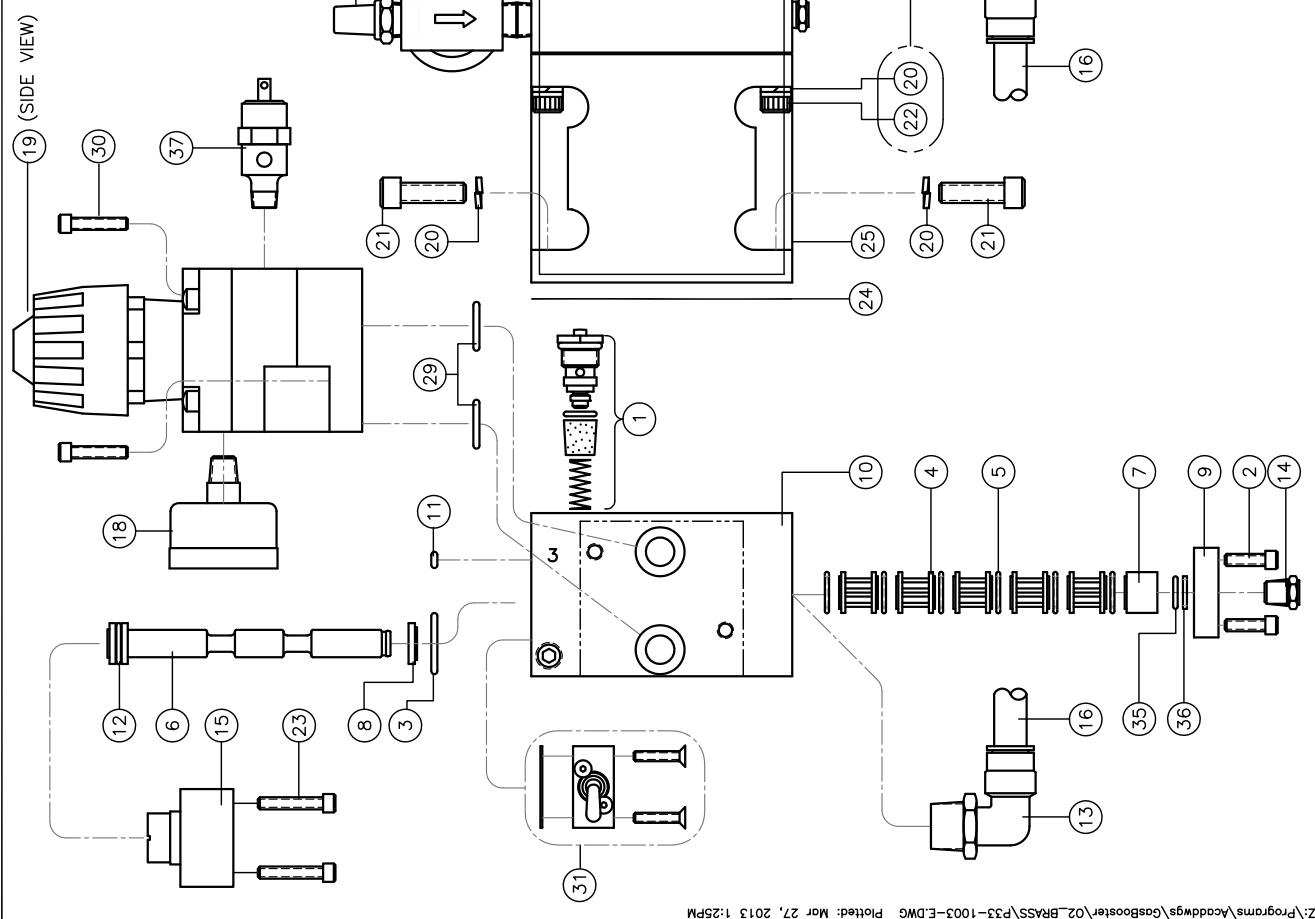

ITEM	QTY	PART NUMBER	DESCRIPTION
40			
39			
38			
37	1	11236 M04-1006	RELIEF VALVE, 1/8 NPT
36	1	11753	TEFLON BU RING, -012
35	1	SO-012P7	O-RING
34			
33			
32	1	10743 V04-1001	VALVE ASSY 3-W TOGGLE
30	2	1/4-20 x .88	SCREW, SOC HD CAP, SS
29	2	SO-016B7	O-RING
28	A/R	IMG311	CHRISTO-LUBE GREASE
27			
26	1	11561 P33-5001	WARNING LABEL
25	1	10111 P12-5202	BODY, AIR CYLINDER
24	1	10334 P00-5205	GASKET, AIR BODY
23	2	10-24 x 1.00 SS	SCREW, SOC HD CAP, SS
22	4	5/16-18 x 2.00SS	SCREW, SOC HD CAP, SS
21	4	5/16-18 x 1.00	SCREW, SOC HD CAP, SS
20	8	12271	L WASHER, 5/16 HI C SS
19	1	10015 P12-1202	AIR REG ASSY
18	1	SEE CHART	AIR GAUGE (0-160 PSI)
17	3	10429	MUFFLER, 1/4 NPT
16	5"	12019	TUBING, NYLON Ø.50 00, GRN
15	1	10298 P00-5207	PILOT CAP
14	1	10264	BREATHER, 1/8 NPT
13	2	12016	MALE ELBOW, 6520-08-08
12	1	SO-111B7	O-RING
11	1	SO-006B7	O-RING
10	1	10004 P12-5201	AIR CAP HOUSING
9	1	10299 P00-5208	SPOOL CAP
8	1	10271 P00-5212	BUSHING, SHORT
7	1	10269 P00-5210	BUSHING, LONG
6	1	10942 P33-5201	AIR SPOOL
5	6	10629	TEE SEAL
4	5	10273 P00-5209	CAGE
3	1	SO-019B7	O-RING
2	2	10-24 x .62 SS	SCREW, SOC HD CAP, SS
1	1	10017 V04-1005	2-WAY AIR VLV ASSY

INTERFACE DEVICES, INC.
 230 DEPOT ROAD
 MILFORD, CT 06460

SCALE: 1/2	TITLE: O2 BOOSTER,
DWN BY: WNI	BILL OF MATERIALS
DATE: 8/15/05	REF: 2005 Version
SHT. 1 OF 2	DWG NO: P33-1003
	REV: E

ASSY P/N	GAUGE	ITEM 18	ITEM 61
11631	STD	10342	10348
12054	CALIB	11997	11995

REV	DESCRIPTION	BY	DATE
A	28 WAS "WATERPROOF GREASE", PICTURE CHANGES; ADDED ITEM 93	WNI	10/11/05
B	ITEM 76 QTY WAS 2; ADDED ITEM 94	WNI	11/21/06
C	DELETED ITEM 91 (11633); ITEM 90 MATL. WAS VITON, NOW PIPE	WNI	12/31/09
D	DELETED 32 & 34. (INCLUDED WITH ITEM 31)	WNI	4/13/11
E	ADD CHART, ITM. 26; DEL. 42 & 77	WNI	11/12/12

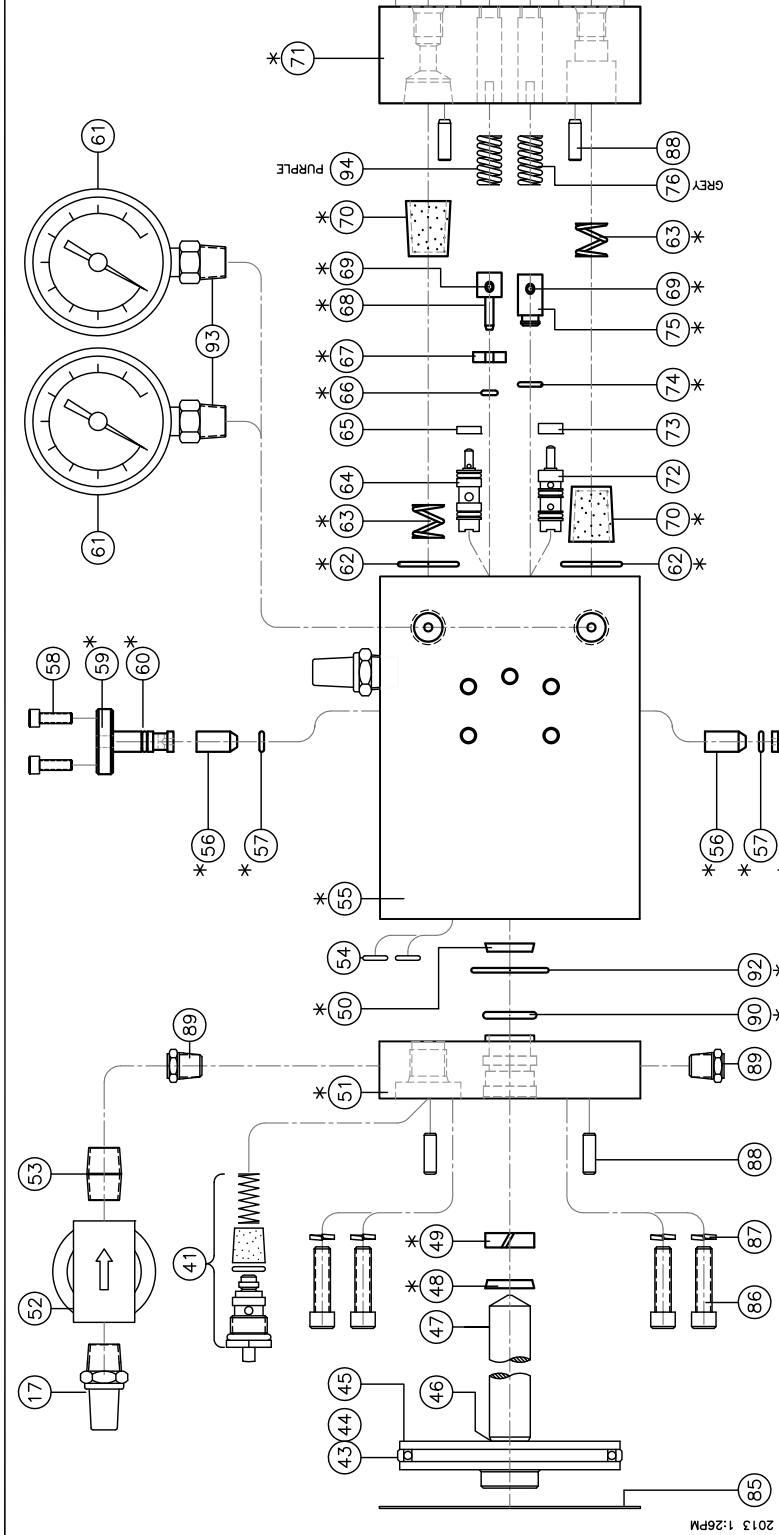

NOTES
 1 PARTS MARKED "*" TO BE CLEANED PER ARP 1176 CATEGORY 1B-200A
 2 WARNING: COMPONENTS SHOWN ON THIS SHEET ARE ASSEMBLED IN A "CLEAN" ROOM. DISASSEMBLY BY UNAUTHORIZED INDIVIDUALS WILL CONTAMINATE THE PUMP AND VOID ALL WARRANTIES

ASSY P/N	GAUGE	ITEM 18	ITEM 61
11631	STD	10342	10348
12054	CALIB	11997	11995

ITEM	QTY	PART NUMBER	DESCRIPTION
55	1	11626 P33-5611	BODY
54	2	SO-011B7	O-RING, BUNA
53	1	12020	CLOSE NIPPLE, BR, 1/4 NPT
52	1	11629 M04-1019	AIR FILTER
51	1	11624 P33-5402	RATIO PLATE
*50	1	11634 M03-1008	VARISEAL (SLANT COIL)
*49	1	11637 M03-1031	ROD BEARING
*48	1	10886 M03-1008	VARISEAL (CANTILEVER)
47	1	11625 P33-5502	PISTON ROD
46	1	SO-902B7	O-RING
45	1	11167 P09-9201	AIR PISTON -2 SAE
44	1	10377	GLYDE RING
43	1	SO-233B7	O-RING
42	1	11635 V04-1010	2-WAY AIR VLV ASSY
ITEM	QTY	PART NUMBER	DESCRIPTION
INTERFACE DEVICES, INC. 230 DEPOT ROAD MILFORD, CT 06460			
SCALE: 1/2 TITLE: O2 BOOSTER, BILL OF MATERIALS			
DWN BY: WNI			
DATE: 8/15/05 REF: 2005 Version			
SHF: 2 OF: 2 DWG NO: P33-1003			
REV: E			

ITEM	QTY	PART NUMBER	DESCRIPTION
70	2	11592 M04-1018	FILTER, 10m
*69	2	12017	SPRING PIN, .009 x .88 SS
*68	1	10488 P33-5606	HI PISTON
*67	1	10609 P33-5610	RETAINER
*66	1	SO-006V7	O-RING, VITON
65	1	10608 P33-5607	RETAINER (.109")
64	1	10451	VALVE, 3-W, NC
*63	2	11630 M01-1001	SPRING, BRASS
*62	4	SO-019V7	O-RING, VITON
*61	2	SFE CHART	GAUGE, 1/4NPT, BRASS, 3K
*60	2	SO-008V7	O-RING, VITON
*59	2	11628 P33-5613	PLUG, CV RETAINER
58	8	8-36 NF x .75	SCREW, SOC HD CAP, SS
*57	4	SO-008V7	O-RING, VITON
*56	2	11632 M04-1002	CHK VALVE (2201D-18-5)
ITEM	QTY	PART NUMBER	DESCRIPTION

ITEM	QTY	PART NUMBER	DESCRIPTION
85	1	10334 P00-5205	GASKET, AIR BODY
*84	2	12022	METAL CAP, ASC-4
*83	2	12018 P33-5614	SEAL .0045 x .06 DISK
*82	2	11975	ST THD CONN, 4F50X-SS
*81	2	SO-904V9	O-RING, VITON
80	2	5/16-24	HEX JAM NUT, SS
79	2	5/16-24 x 1.00	SET SCR, SS
78	13	10-32 x 1.50	SCREW, SOC HD CAP, SS
77	1	11736 M01-1002	SPRING, MW (GREY)
*76	1	10529 P33-5608	LO PISTON
*75	1	SO-010V7	O-RING, VITON
74	1	10610 P33-5609	RETAINER
73	1	10610 P33-5609	RETAINER
72	1	10693	VALVE, 3-W, NO
*71	1	11627 P33-5612	MANIFOLD
ITEM	QTY	PART NUMBER	DESCRIPTION

ITEM	QTY	PART NUMBER	DESCRIPTION
94	1	11737 M01-1002	SPRING, MW (PURPLE)
93	A/R	MIL-T-27730A	TEFLON TAPE
92	1	SO-023V7	O-RING, VITON
*90	1	SO-114PTFE	O-RING, TEFLON®
89	2	10264	BREATHER, 1/8 NPT
88	4	11772	DOWEL PIN, .018 X .62 SS
87	4	12270	LWASHER 1/4 HI COL, SS
86	4	1/4-28 x 1.00	SHCS, SS
ITEM	QTY	PART NUMBER	DESCRIPTION

REV	DESCRIPTION	BY	DATE
A	ITEM 41 WAS 11635 V04-1010	WNI	9/17/14
B	ITEM 19 WAS 10015 P12-1202	WNI	9/17/18

NOTES:

- 1 RECOMMENDED SPARES ITEM: SEAL KIT
- 2 RECOMMENDED SPARES ITEM: OTHER
- 3 LIGHTLY APPLY ITEM 28 "GREASE" TO ALL SEALS AND MATING PARTS AT ASSEMBLY
- 4 WARNING: SOME COMPONENTS ARE ASSEMBLED IN A "CLEAN" ROOM. DISASSEMBLY BEYOND WHAT IS SHOWN ON THIS SHEET WILL CONTAMINATE THE PUMP AND VOID ALL WARRANTIES

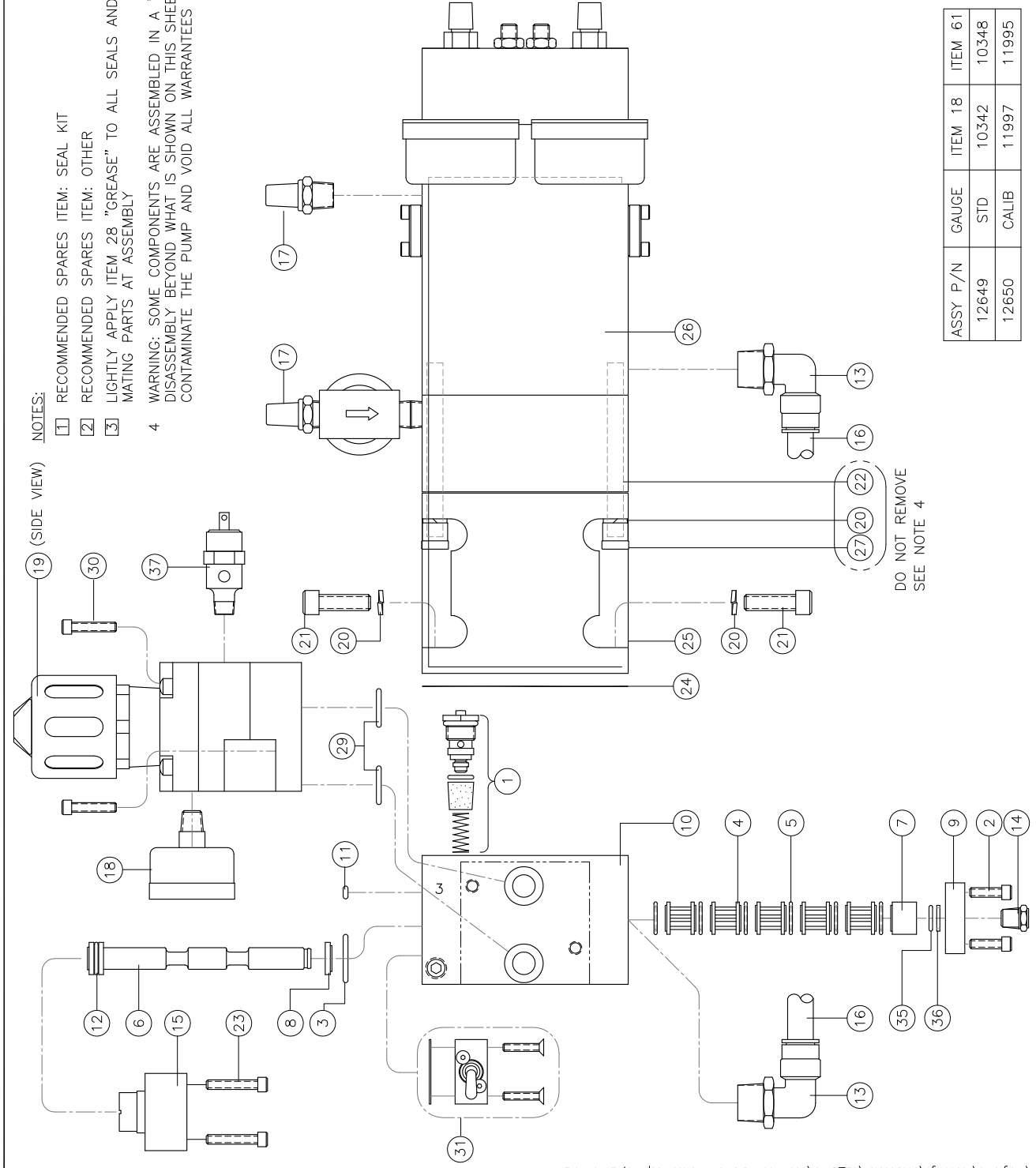

ITEM	QTY	PART NUMBER	DESCRIPTION
40			
39			
38			
37	1	11236 M04-1006	RELIEF VALVE, 1/8 NPT
36	1	11753	TEFLON BU RING, -012
35	1	SO-012P7	O-RING
34			
33			
32	1	10743 V04-1001	VALVE ASSY, 3-W, TOGGLE
30	2	1/4-20 x .88	SCREW, SOC HD CAP, SS
29	2	SO-016B7	O-RING
28	A/R/MCG111		CHRISTO-LUBE GREASE
27	4	12039	ALLEN NUT, 5/16-18
26	1	11561 P33-5001	WARNING LABEL
25	1	10111 P12-5202	BODY, AIR CYLINDER
24	1	10334 P00-5205	GASKET, AIR BODY
23	2	10-24 x 1.00 SS	SCREW, SOC HD CAP, SS
22	4	10751 P33-5404	STUD, 5/16-18
21	4	5/16-18 x 1.00	SCREW, SOC HD CAP, SS
20	8	12271	L WASHER, 5/16 HI C SS
19	1	12286 P12-1206	AIR REG ASSY
18	1	SEE CHART	AIR GAUGE (0-160 PSI)
17	3	10429	MUFFLER, 1/4 NPT
16	5	12019	TUBING, NYLON Ø.50 OD, GRN
15	1	10298 P00-5207	PILOT CAP
14	1	10264	BREATHER, 1/8 NPT
13	2	12016	MALE ELBOW, 6520-08-08
12	1	SO-111B7	O-RING
11	1	SO-006B7	O-RING
10	1	10004 P12-5201	AIR CAP HOUSING
9	1	10299 P00-5208	SPOOL CAP
8	1	10271 P00-5212	BUSHING, SHORT
7	1	10269 P00-5210	BUSHING, LONG
6	1	10942 P33-5201	AIR SPOOL
5	6	10629	TEE SEAL
4	5	10273 P00-5209	CAGE
3	1	SO-019B7	O-RING
2	2	10-24 x .62 SS	SCREW, SOC HD CAP, SS
1	1	10017 V04-1005	2-WAY AIR VLV ASSY

DO NOT REMOVE
SEE NOTE 4

ASSY P/N	GAUGE	ITEM 18	ITEM 61
12649	STD	10342	10348
12650	CALIB	11997	11995

SCALE: 1/2	TITLE: O2 BOOSTER,
DWN BY: WNI	BILL OF MATERIALS
DATE: 2/1/13	REF: 2013 Version
SHF: 1 OF: 2	DWG NO: P33-1004
INTERFACE DEVICES, INC. 230 DEPOT ROAD MILFORD, CT 06460	

REV	DESCRIPTION	BY	DATE
A	ITEM 41 WAS 11635 V04-1010	WNI	9/17/14
B	ITEM 19 WAS 10015 P12-1202	WNI	9/17/18

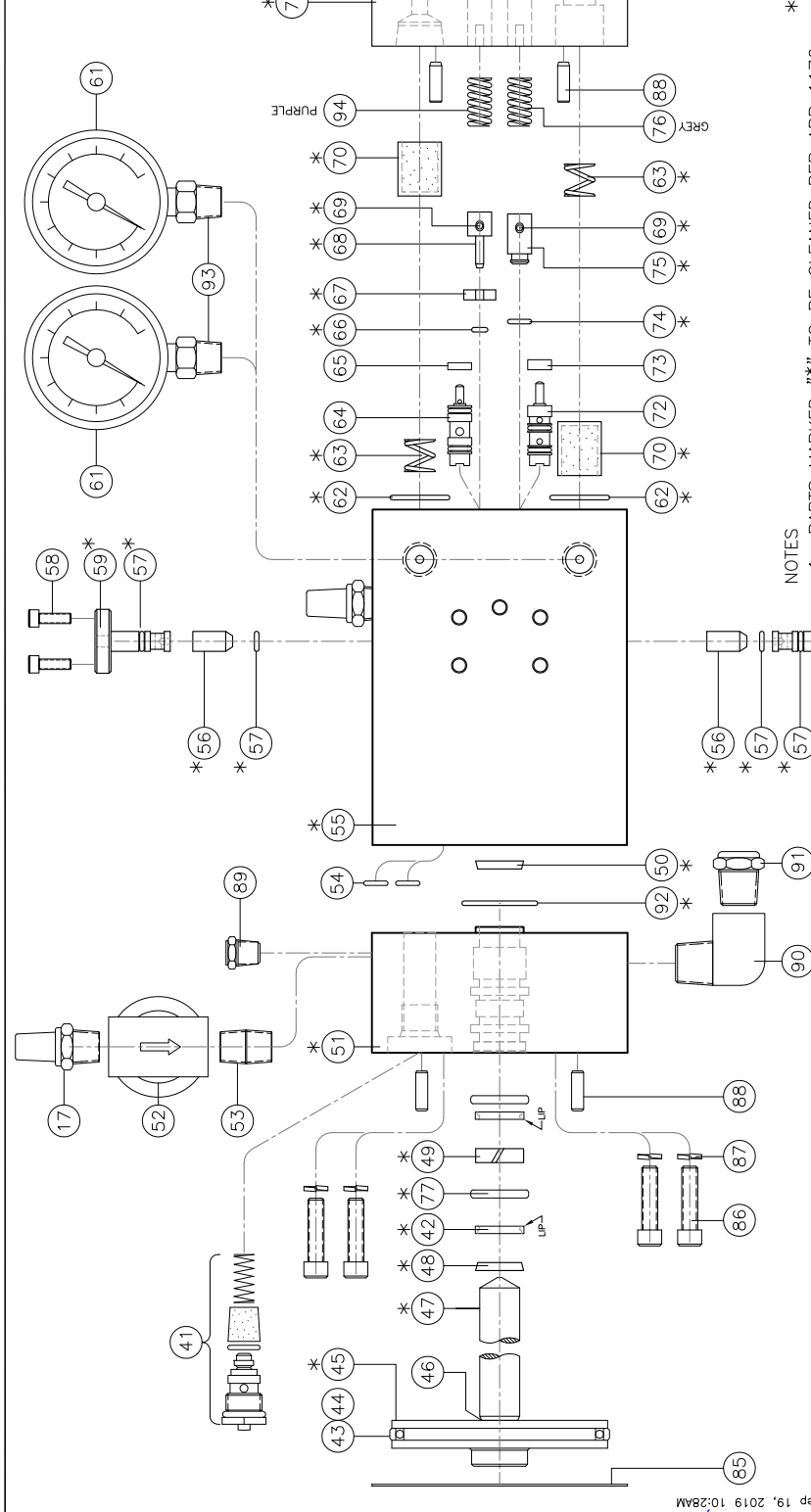

NOTES
 1 PARTS MARKED "*" TO BE CLEANED PER ARP 1176 CATEGORY 1B-200A
 2 WARNING: COMPONENTS SHOWN ON THIS SHEET ARE ASSEMBLED IN A "CLEAN" ROOM. DISASSEMBLY BY UNAUTHORIZED INDIVIDUALS WILL CONTAMINATE THE PUMP AND VOID ALL WARRANTIES

ASSY P/N	GAUGE	ITEM 18	ITEM 61
12649	STD	10342	10348
12650	CALIB	11997	11995

ITEM QTY	PART NUMBER	DESCRIPTION
94	1 11737 M01-1002	SPRING, MW (PURPLE)
93	A/R MIL-1-27730A	TEFLON TAPE
92	1 SO-023V7	O-RING, VITON
91	1 10265 M04-1021	BREATHER, 3/8 NPT
90	1 12089	STREET EL, 3/8 NPT, BRASS
89	2 10264	BREATHER, 1/8 NPT
88	4 11772	DOWEL PIN, Ø18 X .62, SS
87	4 12270	L'WASHER, 1/4 HI COL, SS
86	4 1/4-28 x 1.00	SHCS, SS

ITEM QTY	PART NUMBER	DESCRIPTION
85	1 10334 P00-5205	GASKET, AIR BODY
84	2 12022	METAL CAP, ASC-4
83	2 12018 P33-5614	SEAL, Ø0.45 x .06 DISK
82	2 12245	ST THD CONN, 4F50X-B
81	2 SO-004V9	O-RING, VITON
80	2 5/16-24	HEX JAM NUT, SS
79	2 5/16-24 x 1.00	SET SCR, SS
78	13 10-32 x 1.50	SCREW, SOC HD CAP, SS
77	2 SO-116V7	O-RING, VITON
76	1 11736 M01-1002	SPRING, MW (GREY)
75	1 10529 P33-5608	LO PISTON
74	1 SO-010V7	O-RING, VITON
73	1 10610 P33-5609	RETAINER
72	1 10693	VALVE, 3-W, NO
71	1 11627 P33-5612	MANIFOLD

ITEM QTY	PART NUMBER	DESCRIPTION
70	2 11592 M04-1018	FILTER, 10m
69	2 12017	SPRING PIN, Ø.09 x .88 SS
68	1 10488 P33-5606	HI PISTON
67	1 10609 P33-5610	RETAINER
66	1 SO-006V7	O-RING, VITON
65	1 10608 P33-5607	RETAINER (.109")
64	1 10451	VALVE, 3-W, NC
63	2 11630 M01-1001	SPRING, BRASS
62	2 SO-019V7	O-RING, VITON
61	2 SEE CHART	GAUGE, 1/4NPT, BRASS, 3K
60		
59	2 11628 P33-5613	PLUG, CV RETAINER
58	8 8-36 NF x .75	SCREW, SOC HD CAP, SS
57	4 SO-008V7	O-RING, VITON
56	2 11632 M04-1002	CHK VALVE (220ID-18-5)

ITEM QTY	PART NUMBER	DESCRIPTION
55	1 11626 P33-5611	BODY
54	2 SO-011B7	O-RING, BUNA
53	1 12020	CLOSE NIPPLE, BR, 1/4 NPT
52	1 11629 M04-1019	AIR FILTER
51	1 12647 P33-5403	RATIO PLATE
50	1 11634 M03-1008	VARISEAL (SLANT COIL)
49	1 11637 M03-1031	ROD BEARING
48	1 10886 M03-1008	VARISEAL (CANTILEVER)
47	1 12648 P33-5503	PISTON ROD
46	1 SO-902B7	O-RING
45	1 11167 P09-5201	AIR PISTON -2 SAE
44	1 10377	GLYDE RING
43	1 SO-233B7	O-RING
42	2 12605 M03-1009	STEP SEAL, Ø.62 ID
41	1 10017 V04-1005	2-WAY AIR VLV ASSY

SCALE:	1/2	TITLE:	O2 BOOSTER,
DWG BY:	WNI	BILL OF MATERIALS	
DATE:	2/1/13	REF:	2013 Version
SHF:	2 OF 2	DWG NO:	P33-1004

Pneumatic Division
 Richland, Michigan 49083
 269-629-5000

Appendix A

Installation & Service Instructions
 84-010-000
Coalescing Filter Models
M18 and M28
ISSUED: September, 2007
Supersedes: September, 2006
 Doc. #84010000, EN# 070757, Rev. 5

⚠ WARNING

To avoid unpredictable system behavior that can cause personal injury and property damage:

- Disconnect electrical supply (when necessary) before installation, servicing, or conversion.
- Disconnect air supply and depressurize all air lines connected to this product before installation, servicing, or conversion.
- Operate within the manufacturer's specified pressure, temperature, and other conditions listed in these instructions.
- Medium must be moisture-free if ambient temperature is below freezing.
- Service according to procedures listed in these instructions.
- Installation, service, and conversion of these products must be performed by knowledgeable personnel who understand how pneumatic products are to be applied.
- After installation, servicing, or conversion, air and electrical supplies (when necessary) should be connected and the product tested for proper function and leakage. If audible leakage is present, or the product does not operate properly, do not put into use.
- Warnings and specifications on the product should not be covered by paint, etc. If masking is not possible, contact your local representative for replacement labels.

⚠ CAUTION

Polycarbonate bowls and sight domes, being transparent and tough, are ideal for use with Filters and Lubricators. They are suitable for use in normal industrial environments, but should not be located in areas where they could be subjected to direct sunlight, an impact blow, nor temperatures outside of the rated range. As with most plastics, some chemicals can cause damage. Polycarbonate bowls and sight domes should not be exposed to chlorinated hydro-carbons, ketones, esters and certain alcohols. They should not be used in air systems where compressors are lubricated with fire-resistant fluids such as phosphate ester and di-ester types.

Metal bowls are recommended where ambient and/or media conditions are not compatible with polycarbonate bowls. Metal bowls resist the action of most such solvents, but should not be used where strong acids or bases are present or in salt laden atmospheres. Consult the factory for specific recommendations where these conditions exist.

TO CLEAN POLYCARBONATE BOWLS USE MILD SOAP AND WATER ONLY! DO NOT use cleansing agents such as acetone, benzene, carbon tetrachloride, gasoline, toluene, etc., which are damaging to this plastic.

Bowl guards are recommended for added protection of polycarbonate bowls where chemical attack may occasionally occur.

⚠ WARNING

To avoid polycarbonate bowl rupture that can cause personal injury or property damage, do not exceed bowl pressure or temperature ratings. Polycarbonate bowls have a 150 PSIG pressure rating and a maximum temperature rating of 125°F.

Safety Guide

For more complete information on recommended application guidelines, see the Safety Guide section of Pneumatic Division catalogs or you can download the **Pneumatic Division Safety Guide** at: www.wilkersoncorp.com

INSTALLATION

1. Refer to WARNINGS and CAUTIONS prior to installation.
2. Install as close to the point of use as possible.

3. Unit must be installed with the flow in the direction of the flow arrow on the body cover and with bowl down.
4. Avoid using reducing bushings, couplings, etc., whenever possible to install this product. These devices restrict air flow and can affect performance.
5. Do not install this product in any application where the pressure drop across the unit will exceed 7 psig (0.5 bar). This will cause the Differential Pressure Indicator to shift to RED indicating element replacement is required.
6. Maximum pressure rating is 150 psig (10.3 bar) for plastic bowl/bowl guard assembly, and 250 psig (17.2 bar) for metal bowl with sight gauge. Temperature range is 32°F to 125°F (0°C to 52°C) for plastic bowl/bowl guard assembly, and 32°F to 150°F (0°C to 65.5°C) for metal bowl with sight gauge.
7. To install a drain line, use the following procedure:
 - a. On units with the MANUAL DRAIN, attach flexible tubing having an I.D. of 3/16" (4.8 mm) to drain stem.
 - b. On units with AUTOMATIC FLOAT DRAIN, install using a 3/8 or 10mm ID instant tube fitting or 3/8" ID flexible tubing.

NOTE: CONTAMINATES REMOVED FROM THE COMPRESSED AIR SYSTEM MUST BE DISPOSED OF IN ACCORDANCE WITH LOCAL, STATE AND FEDERAL STANDARDS.

MAINTENANCE

THIS UNIT MAY BE SERVICED WITHOUT REMOVING THE UNIT FROM THE COMPRESSED AIR LINE.

1. Filter element replacement:
 - a. Differential Pressure Indicator is RED indicating that the filter element requires servicing.
 - b. Depressurize unit.
 - c. Remove bowl/bowl guard assembly by pushing up on bowl assembly and turning counter clockwise. Clean inside of bowl using a clean cloth. Inspect plastic bowl for damage and replace if necessary.
 - d. Remove filter element by turning element clockwise.
 - e. Install a new filter element / O-ring seal and reassemble unit in reverse order.

⚠ WARNING

FAILURE OR IMPROPER SELECTION OR IMPROPER USE OF THE PRODUCTS AND/OR SYSTEMS DESCRIBED HEREIN OR RELATED ITEMS CAN CAUSE DEATH, PERSONAL INJURY AND PROPERTY DAMAGE.

This document and other information from The Company, its subsidiaries and authorized distributors provide product and/or system options for further investigation by users having technical expertise. It is important that you analyze all aspects of your application, including consequences of any failure and review the information concerning the product or systems in the current product catalog. Due to the variety of operating conditions and applications for these products or systems, the user, through its own analysis and testing, is solely responsible for making the final selection of the products and systems and assuring that all performance, safety and warning requirements of the application are met.

The products described herein, including without limitation, product features, specifications, designs, availability and pricing, are subject to change by The Company and its subsidiaries at any time without notice.

EXTRA COPIES OF THESE INSTRUCTIONS ARE AVAILABLE FOR INCLUSION IN EQUIPMENT / MAINTENANCE MANUALS THAT UTILIZE THESE PRODUCTS. CONTACT YOUR LOCAL REPRESENTATIVE.

NOTE: DO NOT TOUCH THE EXTERIOR FOAM COVER OF THE ELEMENT. USE THE PLASTIC BAG THE ELEMENT IS SHIPPED IN TO HOLD THE ELEMENT AND INSTALL INTO THE BODY.

2. Liquid level in the bowl must be kept below the level indicator line as marked. It is recommended practice to drain a unit equipped with the manual drain at least once during an eight (8) hour period. **To do so, rotate the drain knob to the left one or two turns.***
3. **Before returning unit to service, insure that all seals have been reinstalled or replaced and bowl is locked into position with drain properly secured.**
4. If the Differential Pressure Indicator no longer functions, it must be replaced.
***NOTE: In the event that the drain knob is over-rotated it may become disengaged from the drain stem. In such a case, pull down on both the knob and the stem while rotating to the right to re-engage.**

DRAINS

Manual Drain	GRP-96-685
Automatic Mechanical Drain (Nitrile)	GRP-95-973
Automatic Mechanical Drain (Fluorocarbon)	GRP-95-981

ACCESSORIES

Joiner set	GPA-96-601
T-Bracket	GPA-96-602
T-Bracket with Joiner set	GPA-96-603
C-Bracket (18 Series)	GPA-96-604
C-Bracket (28 Series)	GPA-96-605
Differential Pressure Indicator	
Nitrile	DP8-01-000
Fluorocarbon	DP8-02-000

Pneumatic Division
 Richland, Michigan 49083
 269-629-5000

Instructions d'installation et Service
84-010-000 (French)

Le Filtre fusionnant Modèle
M18, M28

DISTRIBUE: Septembre, 2007
Supplantent: Septembre, 2006

Doc.# 84010000, EN# 070757, Rev. 5

⚠ AVERTISSEMENT

Afin d'éviter un fonctionnement imprévu du système pouvant occasionner des blessures aux personnes et des dommages matériels :

- Débrancher l'alimentation électrique (si nécessaire) avant toute installation, entretien ou conversion.
- Débrancher l'alimentation en air et dépressuriser toutes les canalisations d'air connectées à cet appareil avant installation, entretien ou conversion.
- Utiliser l'appareil conformément aux normes de pression, température, et autres conditions spécifiées par le fabricant dans ces instructions.
- Le médium doit être exempt d'humidité si la température descend en dessous de 0°C.
- L'entretien doit se faire conformément aux procédures décrites ici.
- L'installation, l'entretien, et la conversion de ces appareils doivent être effectués par des personnels qualifiés, au fait des techniques pneumatiques.
- Après installation, entretien, ou conversion, les alimentations en air et en électricité (si nécessaire) seront connectées et l'appareil testé pour vérifier son fonctionnement correct et l'absence de fuites. Si l'appareil présente une fuite audible ou ne fonctionne pas correctement, ne pas l'utiliser.
- Les inscriptions concernant les avertissements et spécifications sur l'appareil ne devront pas être recouvertes de peinture, etc. Si le masquage est impossible, contactez votre représentant local pour des étiquettes de remplacement.

⚠ ATTENTION

Les bols en polycarbonates et apercevoir des dômes, étant durs et transparents, sont idéaux pour l'utilisation dans les filtres et lubrificateurs. Ils conviennent aux environnements industriels normaux, mais ne devront pas être placés dans des endroits où ils pourraient être soumis à une exposition à la lumière directe du soleil, aux chocs, ou aux températures en-dehors de la plage normale d'utilisation. Ce plastique est, comme tout autre, susceptible d'être endommagé par l'action de certains produits chimiques. Les bols en polycarbonate et apercevoir des dômes ne doivent pas être exposés aux hydrocarbures chlorés, cétones, éthers, et certains alcools. Ils ne doivent pas être utilisés dans des systèmes pneumatiques dont les compresseurs sont lubrifiés par des fluides résistant au feu, tels que les esters et diesters de phosphate.

Les bols métalliques sont recommandés quand les conditions ambiantes et/ou celles du médium sont incompatibles avec les bols en polycarbonates. Les bols métalliques sont résistants à la plupart de ces solvants mais ne doivent pas être utilisés en milieu fortement acide ou basique, ou dans une atmosphère salée. Si de telles conditions existent, contactez le fabricant pour des recommandations spécifiques.

NETTOYEZ LES BOLS EN POLYCARBONATE UNIQUEMENT A L'EAU ET AU SAVON DOUX ! NE PAS utiliser d'agents nettoyants tels que l'acétone, le benzène, le tétrachlorure de carbone, l'essence, le toluène, etc., qui endommageraient ce plastique.

De plus, il est recommandé d'équiper les bols en polycarbonates de carters de protection, là où une agression chimique est possible.

⚠ AVERTISSEMENT

Pour éviter le rupture de bol de polycarbonate qui peut causer la blessure personnels ou les dommages de propriété, ne pas dépasser la pression de bol ou les classements de température. Les bols de Polycarbonate ont une 150 pression de PSIG évaluant et une température maximum évaluant de 125°F.

Guide de sécurité

Pour obtenir de plus amples informations sur les directives à appliquer recommandées, prière de vous reporter à la section Guide de sécurité des catalogues de la Pneumatic Division ou de télécharger le Guide de sécurité de la Pneumatic Division sur le site: www.wilkersoncorp.com

3. Ce dispositif doit être monté de manière à ce que le débit soit orienté dans la direction de la flèche placée sur l'enveloppe du corps, le bol étant vers le bas.
4. Éviter dans toute la mesure du possible d'utiliser des bagues, raccords ou autres dispositifs de réduction pour installer ce produit. Ils diminuent le débit d'air et risquent d'affecter le fonctionnement.
5. Ne pas installer ce dispositif sur les systèmes où la différence de pression entre l'entrée et la sortie du dispositif est appelée à dépasser 0.55 bar (8 psig). Dans ce cas, l'indicateur de pression différentielle devient ROUGE, ce qui indique qu'il faut remplacer l'élément filtrant.
6. La pression maximale d'utilisation est de 10.3 bar (150 psig) pour bol/protège-bol en plastique, et 17.2 bar (250 psig) pour bol en métal avec jauge visuelle. La température d'utilisation se situe entre 0°C et 52°C (de 32°F à 125°F) pour bol/protège-bol en plastique, et 0°C et 65.5°C (de 32°F à 150°F) pour bol en métal avec jauge visuelle.
7. Pour mettre en place une conduite de vidange, procéder comme suit:
 - a. Sur les modèles à VIDANGE MANUELLE, raccorder un tuyau flexible de 4.8 mm (3/16") de diamètre intérieur au raccord de vidange.
 - b. Sur les modèles à VIDANGE AUTOMATIQUE À FLOTTEUR, installer utilisant un 3/8 ou 10 mm ID installation de tube immédiate ou 3/8" tuyaux de flexibile d'ID.

NOTE : LES CONTAMINANTS ÔTÉS DU SYSTÈME À AIR COMPRIMÉ DOIVENT ÊTRE MIS AU REBUT CONFORMÉMENT AUX RÈGLEMENTS LOCAUX, PROVINCIAUX ET FÉDÉRAUX.

ENTRETIEN

L'ENTRETIEN DE CE DISPOSITIF PEUT S'EFFECTUER SANS LE DÉMONTER DE LA CONDUITE D'AIR COMPRIMÉ.

1. Remplacement de l'élément filtrant:
 - a. Remplacer l'élément quand l'indicateur de pression différentielle est ROUGE.
 - b. Mettre le dispositif hors pression.
 - c. Ôter l'ensemble de bol/protège-bol en poussant l'ensemble vers le haut et en le tournant dans le sens horaire. Nettoyer l'intérieur du bol avec un chiffon sec et propre. Examiner le bol pour s'assurer qu'il n'est pas endommagé et le remplacer si nécessaire.

⚠ AVERTISSEMENT

LA DEFAILLANCE, LE CHOIX ERRONE OU L'USAGE NON CONFORME DES PRODUITS ET/OU SYSTEMES ICI DECRITS, OU PRODUITS Y AFFERANT, PEUVENT ENTRAINER LA MORT, DES BLESSURES AUX PERSONNES ET DES DOMMAGES MATERIELS.

Ce document et autres informations de « The Company », ses filiales et distributeurs autorisés offre des options complémentaires d'utilisation du produit et/ou système pour des utilisateurs ayant l'expertise technique requise. Il est important que vous analysiez tous les aspects de l'usage prévu, y compris les conséquences de toute défaillance, et que vous passiez en revue les informations concernant les produits et systèmes dans le catalogue actuel des produits. En raison de la diversité des conditions de fonctionnement et d'utilisation de ces produits ou systèmes, l'utilisateur, et lui seul, selon ses propres analyses et tests, porte la responsabilité du choix final des produits et systèmes. Il est aussi de sa responsabilité pleine et entière de s'assurer que les produits soient utilisés conformément aux normes de sécurité et avertissements d'usage.

Les produits décrits ici, y compris, mais non exclusivement, les caractéristiques des produits, spécifications, aspects, disponibilité et prix, sont susceptibles de modification à tout moment et sans préavis par « The Company » et ses filiales.

DES EXEMPLAIRES SUPPLEMENTAIRES DE CES INSTRUCTIONS SONT DISPONIBLES POUR ACCOMPAGNER LES APPAREILS/MANUELS D'ENTRETIEN CORRESPONDANT A CES PRODUITS. CONTACTEZ VOTRE REPRESENTANT LOCAL.

INSTALLATION

1. Lire l'avertissement ci-haut avant l'installation.
2. Installer le dispositif aussi près du point d'utilisation que possible.

- d. Démonter l'élément filtrant en le tournant dans le sens horaire.
- e. Installer un nouvel élément filtrant et un nouveau joint torique.
Remonter le dispositif en procédant en sens inverse.

NOTE : NE PAS TOUCHER À LA COUCHE EXTÉRIEURE EN MOUSSE DE L'ÉLÉMENT. SE SERVIR DU SAC EN PLASTIQUE DANS LEQUEL L'ÉLÉMENT EST

LIVRÉ POUR LE TENIR ET L'INSTALLER DANS LE CORPS.

- 2. Le niveau de liquide dans le bol doit être maintenu en-dessous du repère. Il est recommandé de vidanger les régulateurs à vidange manuelle au moins une fois toutes les huit (8) heures. Pour cela, tourner le bouchon de vidange vers la gauche d'un ou deux tours.*
- 3. **Avant de remettre le dispositif en service, vérifier que tous les joints ont bien été remis en place ou remplacés et que le bol est verrouillé en position avec le bouchon/écrou de vidange bien serré.**
- 4. **Si l'indicateur de pression différentielle ne fonctionne plus, il doit être remplacé.**

***NOTE: Au cas où l'on dévisse le bouchon de vidange jusqu'au point où il se sépare du tube de vidange, exercer une traction sur le bouchon et sur le tube de vidange simultanément en tournant le bouchon vers la droite pour le ré-engager.**

DISPOSITIFS DE VIDANGE

- Dispositif de vidange manuelle..... **GRP-96-685**
- Dispositif de vidange automatique
mécanique (nitrile)..... **GRP-95-973**
- Dispositif de vidange automatique
mécanique (fluorocarbone)..... **GRP-95-981**

ACCESSOIRES

- Jeu de montage..... **GPA-96-601**
- Support en T..... **GPA-96-602**
- Support en T avec jeu de montage..... **GPA-96-603**
- Support en C (série 18)..... **GPA-96-604**
- Support en C (série 28)..... **GPA-96-605**
- Indicateur de pression différentielle
Nitrile **DP8-01-000**
Fluorocarbone **DP8-02-000**

Pneumatic Division
 Richland, Michigan 49083
 269-629-5000

Las Instrucciones de la instalación y el Servicio 84-010-000 (Spanish)

El Filtro que se une Modela M18 y M28

PUBLICADO: Septiembre, 2006

Desbancan: Septiembre, 2006

Doc.# 84010000, EN# 070757, Rev. 5

⚠ ADVERTENCIA

Para evitar un comportamiento impredecible del sistema que pueda ocasionar lesiones personales y daños a la propiedad:

- Antes de instalar, reparar o convertir, desconecte el suministro eléctrico (cuando sea necesario).
- Antes de instalar, reparar o convertir, desconecte el suministro de aire y despresurice todas las líneas de aire que están conectadas a este producto.
- Haga funcionar dentro de la presión, temperatura y demás condiciones especificadas por el fabricante y que se incluyen en estas instrucciones.
- El medio debe estar libre de humedad si la temperatura ambiente se encuentra por debajo del punto de congelación.
- Repare de acuerdo con los procedimientos que se incluyen en estas instrucciones.
- La instalación, reparación y conversión de estos productos debe ser realizada por personal competente que entienda la manera en que se deben aplicar los productos neumáticos.
- Después de la instalación, reparación y conversión, se debe conectar los suministros eléctricos y de aire (cuando sea necesario), y el producto se debe poner a prueba para determinar que funciona correctamente y no tiene pérdidas. Si se detecta una pérdida audible, o si el producto no funciona correctamente, no lo ponga en funcionamiento.
- Las advertencias y especificaciones que aparecen en el producto no deben estar cubiertas por pintura, etc. Si no resulta posible colocarlo con cinta adhesiva, póngase en contacto con su representante local para obtener etiquetas de repuesto.

⚠ PRECAUCIÓN

Las tazas de policarbonato y cúpulas videntes, al ser transparentes y resistentes, son ideales para usar con Filtros y Lubricadores. Son aptas para usar en ambientes industriales normales, pero no se deben ubicar en zonas en donde queden expuestas a luz solar directa, un golpe de impacto, o una temperatura por fuera de su clasificación. Al igual que con la mayoría de los plásticos, ciertos productos químicos pueden ocasionar daños. No se debe exponer las tazas de policarbonato y cúpulas videntes a los hidrocarburos clorinados, las cetonas, los ésteres y ciertos alcoholes. No se los debe usar en sistemas de aire en donde se lubrica los compresores de aire usando fluidos resistentes al fuego tal como los tipos de éster fosfato y di-éster.

Se recomienda el uso de tazas de metal cuando las condiciones ambientales y del medio no son compatibles con las tazas de policarbonato. Las tazas de metal son resistentes a la acción de la mayoría de esos solventes, pero no deben usarse cuando existe la presencia de ácidos o bases fuertes, ni en atmósferas cargadas de sal. Consulte con la fábrica por recomendaciones específicas para cuando existen estas condiciones.

PARA LIMPIAR LAS TAZAS DE POLICARBONATO, UTILICE SOLAMENTE UN JABÓN SUAVE Y AGUA. NO use agentes de limpieza tales como la acetona, el benceno, el tetracloruro de carbono, la gasolina o el tolueno, etc., que pueden dañar este plástico.

Se recomienda los protectores de taza para dar una protección adicional a las tazas de policarbonato en aquellos casos en que pueda ocurrir un ataque químico.

⚠ ADVERTENCIA

Para evitar ruptura de tazón de polycarbonato que puede causar el daño personal de la herida o la propiedad, no excede la presión de tazón o calificaciones de temperatura. Los tazones de Polycarbonato tienen una 150 presión de PSIG que valora y una temperatura máxima que valora de 125°F.

Guía sobre la seguridad

Para obtener información más completa acerca de los lineamientos recomendados acerca del uso, vea la sección Guía sobre la seguridad en los catálogos de la división neumática o puede bajar la Guía sobre la Seguridad de la División Neumática (Pneumatic Division Safety Guide) en www.wilkinsoncorp.com

INSTALACION

1. Remítase a la ADVERTENCIA antes de proceder a la instalación.
2. Efectúe la instalación lo más cerca posible del punto de uso.

3. La unidad se debe instalar con el flujo en dirección de la flecha de flujo en la cubierta del cuerpo y con la taza hacia abajo.
4. Evite utilizar casquillos reductores, acopladores reductores, etc., siempre que sea posible al instalar este producto. Estos dispositivos restringen el flujo de aire y pueden afectar el rendimiento.
5. No instale este producto en ninguna aplicación donde la caída de presión de la unidad exceda de 0.55 barías (8 psig). Esto causará que el indicador de diferencia de presión cambie a RED (ROJO), lo cual indica que se requiere cambiar el elemento.
6. La clasificación de presión máxima es de 10.3 barías (150 psig) de las taza de plástico/ensamble del protector de la taza, y 17.2 barías (250 psig) de las taza de metal con indicador visual de nivel. El rango de temperatura es de 0°C a 52°C (32°F a 125°F) de las taza de plástico/ensamble del protector de la taza, y 0°C a 65.5°C (32°F a 150°F) de las taza de metal con indicador visual de nivel.
7. Para instalar un conducto de drenaje, siga el siguiente procedimiento:
 - a. En las unidades con DRENAJE MANUAL, acople un tubo flexible que tenga un diámetro interior de 4.8 mm (3/16") al vástago de drenaje.
 - b. En las unidades con DRENAJE DE FLOTACION AUTOMATICO, Instale utilizando un 3/8 o 10 Mm identificación quedar instantáneo de tubo o 3/8" tubería de flexible de identificación.

NOTA: SE DEBEN ELIMINAR LOS CONTAMINANTES DEL SISTEMA DE AIRE COMPRIMIDO DE CONFORMIDAD CON LAS NORMAS FEDERALES, ESTATALES Y LOCALES.

MANTENIMIENTO

SE PUEDE DAR SERVICIO A ESTA UNIDAD SIN RETIRARLA DEL CONDUCTO DE AIRE COMPRIMIDO.

1. Cambio del elemento del filtro:
 - a. El indicador de la diferencia de presión está en RED (ROJO), lo cual indica que el elemento del filtro requiere servicio.
 - b. Despresurice la unidad.
 - c. Retire la taza y el ensamble del protector de la taza tirando del ensamble de la taza hacia arriba y girando en el sentido de las manecillas del reloj. Limpie el interior de la taza utilizando un paño

⚠ ADVERTENCIA

EL FALLO O LA SELECCIÓN INCORRECTA O EL USO INCORRECTO DE LOS PRODUCTOS Y/O SISTEMAS AQUÍ DESCRITOS U OTROS ARTICULOS RELACIONADOS PUEDE RESULTAR EN MUERTE, LESIONES PERSONALES Y DAÑO A LA PROPIEDAD.

Este documento y demás información de la compañía, sus subsidiarias y distribuidores autorizados ofrecen opciones de productos y sistemas para mayor investigación por parte de los usuarios que cuentan con conocimientos técnicos. Es importante que analice todos los aspectos de su aplicación, incluyendo las consecuencias de cualquier fallo y que revise la información concerniente al producto o los sistemas que se encuentran en el catálogo actual de productos. Debido a la variedad de condiciones de funcionamiento y aplicaciones para estos productos o sistemas, el usuario, mediante su propio análisis y pruebas, es únicamente responsable por la selección final de los productos y sistemas, y por garantizar que se cumpla con todos los requisitos de funcionamiento, seguridad y advertencia de la aplicación.

Los productos aquí descritos, incluyendo pero sin limitarse, a las características del producto, las especificaciones, los diseños, la disponibilidad y los precios, están sujetos a cambios por parte de la compañía y de sus subsidiarias en cualquier momento sin aviso.

SE PUEDE OBTENER COPIAS ADICIONALES DE ESTAS INSTRUCCIONES PARA INCLUIR CON EL EQUIPO / LOS MANUALES DE MANTENIMIENTO QUE UTILIZAN ESTOS PRODUCTOS. COMUNIQUESE CON SU REPRESENTANTE LOCAL.

limpio y seco. Revise la taza de plástico por si hubiera daños y cámbiela si fuera necesario.

- d. Retire el elemento del filtro girando el elemento en el sentido de las manecillas del reloj.
- e. Instale un nuevo elemento del filtro/junta tórica y vuelva a armar la unidad en orden inverso.

NOTA: NO TOQUE LA CUBIERTA DE ESPUMA EXTERIOR DEL ELEMENTO. UTILICE LA BOLSA DE PLASTICO EN QUE SE ENVIA EL ELEMENTO PARA SUJETAR EL MISMO AL INSTALARLO EN EL INTERIOR DEL CUERPO.

2. El nivel de líquido en la taza se debe mantener por debajo de la línea indicadora del nivel según está marcada. Se recomienda drenar la unidad equipada con drenaje manual por lo menos una vez en un período de ocho (8) horas. **Para hacerlo, gire la perilla de drenaje hacia la izquierda una o dos vueltas.***
3. **Antes de regresar la unidad al servicio, asegúrese de que se hayan reinstalado o cambiado debidamente todas las juntas y que se haya fijado la taza en posición con el drenaje debidamente asegurado.**
4. **Si el indicador de la diferencia de presión ya no funciona, se lo debe cambiar.**

***NOTA: En caso de que se gire la perilla de drenaje en exceso, puede desengancharse de la espiga de drenaje. En tal caso, tire hacia abajo la perilla y la espiga mientras gira hacia la derecha para volver a enganchar.**

DRENAJES

- Drenaje manual GRP-96-685
- Drenaje mecánico automático (Nitrilo) GRP-95-973
- Drenaje mecánico automático (Fluorocarbono) GRP-95-981

ACCESORIOS

- Juego de ensamble GPA-96-601
- Ménsula en forma de T GPA-96-602
- Ménsula en forma de T con juego de ensamble GPA-96-603
- Ménsula en forma de C (Serie 18) GPA-96-604
- Ménsula en forma de C (Serie 28) GPA-96-605
- Indicador de diferencia de presión
 - Nitrilo DP8-01-000
 - Fluorocarbono DP8-02-000

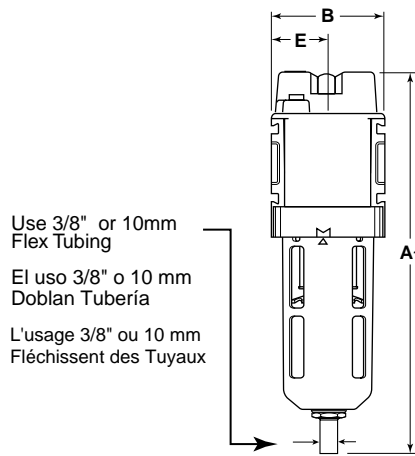

Use 3/8" or 10mm Flex Tubing
 El uso 3/8" o 10 mm Doblan Tubería
 L'usage 3/8" ou 10 mm Fléchissent des Tuyaux

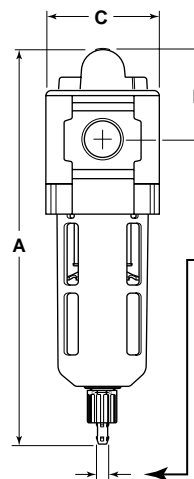

0.19" (4.7 mm) I.D. Tube Barb Fitting
 Raccord cannelé de 4.7 mm (0.19" dia. int.)
 Accesorio dentado de tubo con un diámetro interior de 0.19" (4.7 mm)

FRONT VIEW (Automatic Drain)
VUE DE FACE (Egout automatique)
VISTA DELANTERA (Desaguadero automático)

SIDE VIEW (Manual Drain)
VUE DE CÔTÉ (Egout manuel)
VISTA LATERAL (Desaguadero manual)

Models Modèles Modelos	A	A1	B	C	D	E
M18	8.2 (209)	7.97 (202)	2.36 (60)	2.26 (57)	1.9 (48)	1.2 (30)
M28	9.3 (213)	9.07 (230)	2.9 (73)	2.9 (73)	1.9 (48)	1.4 (37)

REPAIR KITS AND REPLACEMENT PARTS
TROUSSES DE RÉPARATION ET PIÈCES DE RECHANGE
JUEGOS DE REPARACION Y REPUESTOS

	Element Type C 0.01 micron	Element Type B 0.5 micron	Element Type D Activated Carbon	Bowl O-ring Nitrile	Plastic Bowl/ Bowl Guard with Manual Drain	Plastic Bowl/ Bowl Guard with Automatic Drain	Plastic Bowl/ Bowl Guard with No Drain	Metal Bowl/ Sight Gauge with Manual Drain	Metal Bowl/ Sight Gauge with Automatic Drain
	Élément Type C 0.01 micron	Élément de Type B 0.05 micron	Élément de Type D carbone activé	Joint torique de bol en nitrile	Bol en plastique/ protège-bol à vidange manuelle	Bol en plastique/ protège-bol à vidange automatique	Bol en plastique/ protège-bol sans vidange	Bol en métal à jauge visuelle à vidange manuelle	Bol en métal à jauge visuelle à vidange automatique
	Elemento Tipo C 0.01 micrones	Elemento Tipo B 5 micrones	Elemento Tipo D carbón activado	Junta tórica de la taza Nitrilo	Taza de plástico/ Protector de la taza con drenaje manual	Taza de plástico/ Protector de la taza con drenaje automático	Taza de plástico/ Protector de la taza sin drenaje	Taza de metal/ visual de nivel con drenaje manual	Taza de metal/ Indicador visual de nivel con drenaje automático
M18	MTP-96-646	MSP-96-647	MXP-69-650	GRP-96-640	GRP-96-634	GRP-96-635	GRP-96-638	GRP-96-636	GRP-96-637
M28	MTP-96-648	MSP-96-649	MXP-96-651	GRP-96-654	GRP-96-642	GRP-96-643	GRP-96-652	GRP-96-644	GRP-96-645

• **Coalescing Filter Models M18 and M28**

• **Filtre coalescent modèles M18 et M28**

• **Filtro coalescente Modelos M18 y M28**

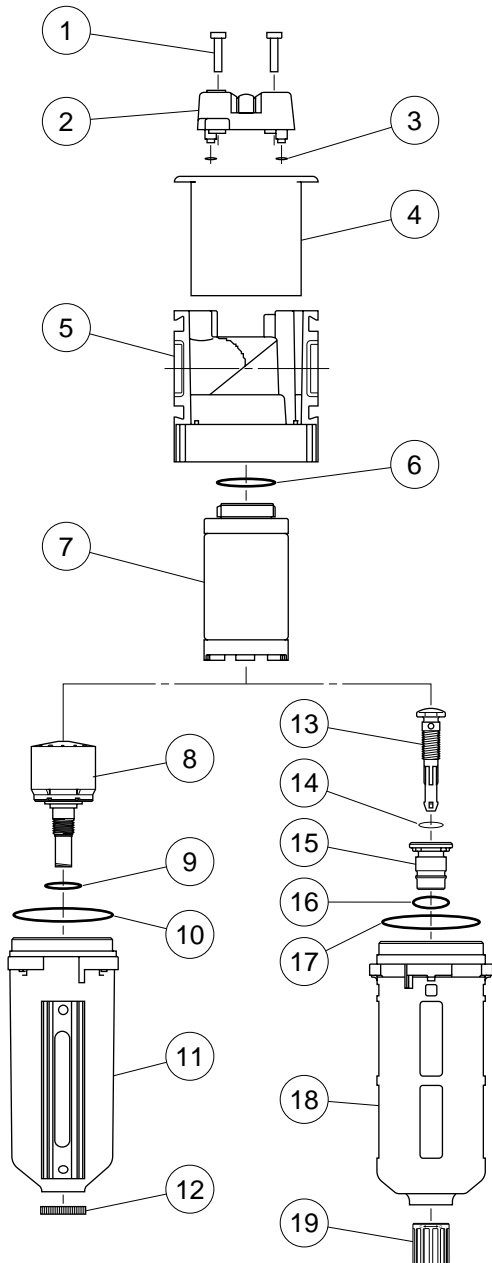

- ① SELF-TAPPING SCREWS
VIS AUTOTARAUEUSES
TORNILLOS AUTORROSCANTES
- ② DIFFERENTIAL PRESSURE INDICATOR
INDICATEUR DE PRESSION DIFFÉRENTIELLE
INDICADOR DE DIFERENCIA DE PRESION
- ③ DIFFERENTIAL PRESSURE INDICATOR O-RINGS
JOINTS TORIQUES D'INDICATEUR DE PRESSION DIFFÉRENTIELLE
JUNTAS TORICAS DEL INDICADOR DE DIFERENCIA DE PRESION
- ④ BODY COVER
ENVELOPPE DU CORPS
CUBIERTA DEL CUERPO
- ⑤ BODY
CORPS
CUERPO
- ⑥ ELEMENT O-RING
JOINT TORIQUE D'ÉLÉMENT
JUNTA TORICA DEL ELEMENTO
- ⑦ 0.5 MICRON ELEMENT
ÉLÉMENT DE 0.5 MICRON
ELEMENTO DE 5 MICRONES
- ⑧ AUTOMATIC FLOAT DRAIN
DISP. DE VIDANGE AUTOMATIQUE À FLOTTEUR
DRENAJE DE FLOTACION AUTOMATICO
- ⑨ DRAIN SEAT O-RING
JOINT TORIQUE DE SIÈGE DE VIDANGE
JUNTA TORICA DEL ASIENTO DE DRENAJE
- ⑩ BOWL O-RING
JOINT TORIQUE DE BOL
JUNTA TORICA DE LA TAZA
- ⑪ METAL BOWL with SIGHT GAUGE
BOL EN MÉTAL avec JAUGE VISUELLE
TAZA DE METAL con INDICADOR VISUAL DE NIVEL
- ⑫ AUTOMATIC DRAIN NUT
ÉCROU DE DISP. DE VIDANGE AUTOMATIQUE
TUERCA DE DRENAJE AUTOMATICO
- ⑬ DRAIN STEM
TIGE DE VIDANGE
VASTAGO DE DRENAJE
- ⑭ DRAIN STEM O-RING
JOINT TORIQUE DE TIGE DE VIDANGE
JUNTA TORICA DEL VASTAGO DE DRENAJE
- ⑮ DRAIN SEAT
SIÈGE DE VIDANGE
ASIENTO DE DRENAJE
- ⑯ AUTO DRAIN O-RING
JOINT TORIQUE DE DISP. DE VIDANGE
JUNTA TORICA DE DRENAJE AUTO-MATICO
- ⑰ BOWL O-RING
JOINT TORIQUE DE BOL
JUNTA TORICA DE LA TAZA
- ⑱ PLASTIC BOWL/
BOWL GUARD ASSEMBLY
ENSEMBLE DE BOL EN PLASTIQUE/PROTÈGE-BOL
TAZA DE PLASTICO/EN-SAMBLE DEL PROTECTOR DE LA TAZA
- ⑲ DRAIN KNOB
BOUCHON DE VIDANGE
PERILLA DE DRENAJE

XS Series Excess Flow Valve Service Instructions

Contents

- Component Identification 1
- Tool Requirements 2
- Installation 2
- Testing 2
- Kit Contents 3
- Maintenance 3
- Troubleshooting 6

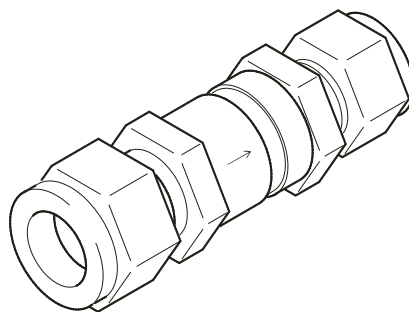

Valve is shown with Swagelok® tube fitting end connections. These instructions also apply to XS series valves with pipe ends and with VCR® and VCO® face-seal fitting end connections.

Component Identification

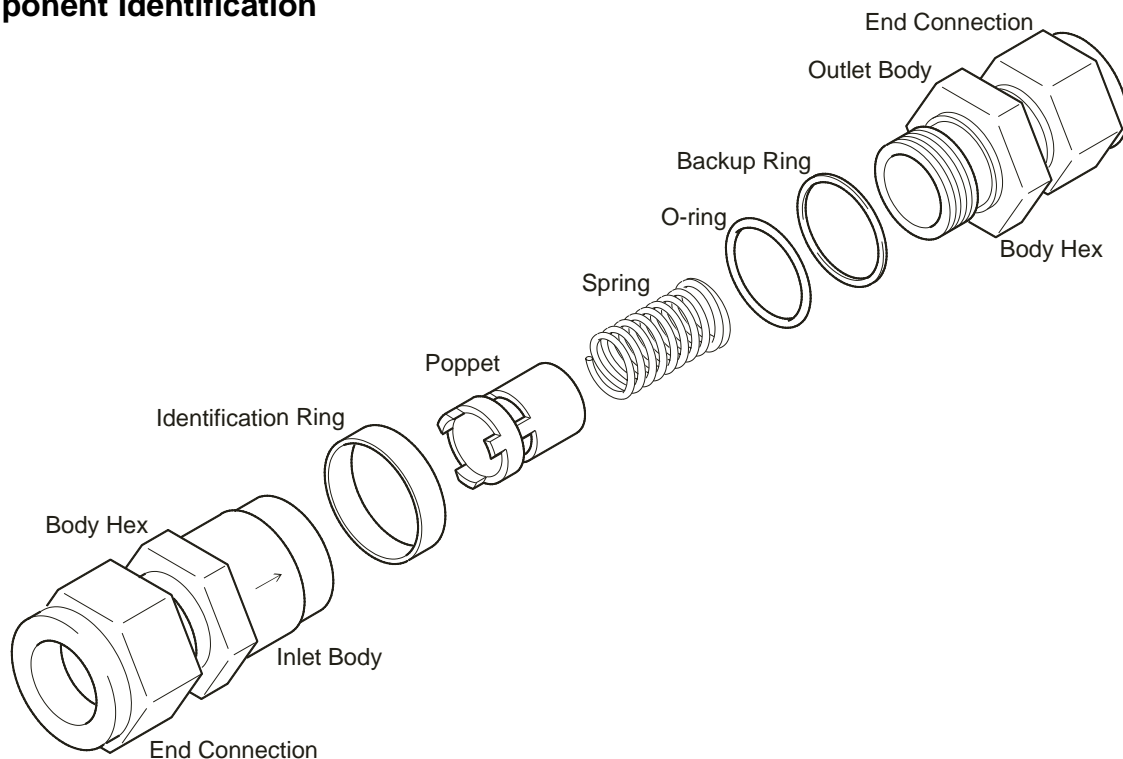

Definitions

Statements and symbols are used in this document to identify safety concerns. Read the definitions below before performing the service instructions.

Caution: Indicates a potentially hazardous situation. It may also be used to alert against unsafe practices.

Notice: Indicates a statement of company policy directly or indirectly related to the safety of personnel or protection of property.





This symbol indicates cautionary information.

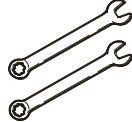

Tool Requirements

Tool size depends on the nominal end connection size and style. See the table below.

Nominal End Connection Size	Tool Size and Quantity		
	Wrenches		Socket
	For Body Hex Qty. (2)	For End Connection Qty. (1)	For Body Hex Qty. (1)
1/8 in.		 7/16 in.	
1/4 in.		9/16 in.	
6 mm		14 mm	
3/8 in.	1 in.	11/16 in.	1 in.
1/2 in.		7/8 in.	
1/2 in. FNPT	1 1/16 in.	1 1/16 in.	1 1/16 in.
1/2 in. BSP/ISO		1 1/16 in.	
8 mm	1 in.	16 mm	1 in.
12 mm		22 mm	

Other Tools

Torque wrench rated to 200 in-lb (22.6 N-m).

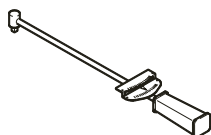

Caution:

Before servicing any installed valve you must:

- depressurize the system
- purge the valve.

Installation

1. Refer to the flow direction arrow on the excess flow valve and install the valve in the correct orientation.



The flow direction verification card included with the valve shows the proper flow direction.

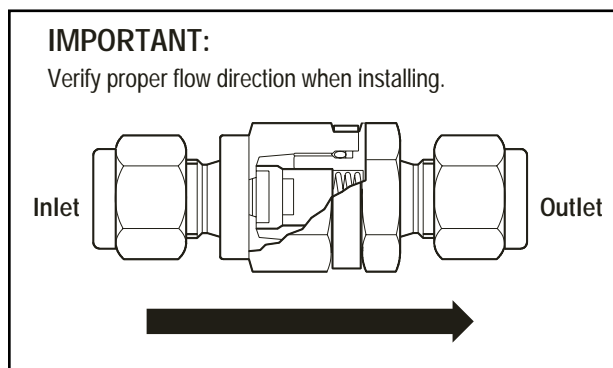

Flow Direction Verification Card

2. For valves with Swagelok tube fittings or VCO® or VCR® fittings, following the specific fitting assembly instructions.
3. For valves with pipe fittings or straight thread fittings, follow standard industry practices.

Testing

1. Operate at normal flow rate. Create maximum flow surges. Valve must remain open in both instances.
2. Vent system line to simulate a break. Valve must trip (close).
 - If valve trips closed, proceed to step 3.
 - If valve does not trip closed, replace the spring with one of the lower-flow springs. Repeat the Testing procedure.
3. Perform reset test by venting system to trip valve. Close upstream or downstream valve to allow the valve to reset. Valve must open and allow normal flow.
4. Test the valve to ensure there is no leakage to the atmosphere.

Spring Kit Contents

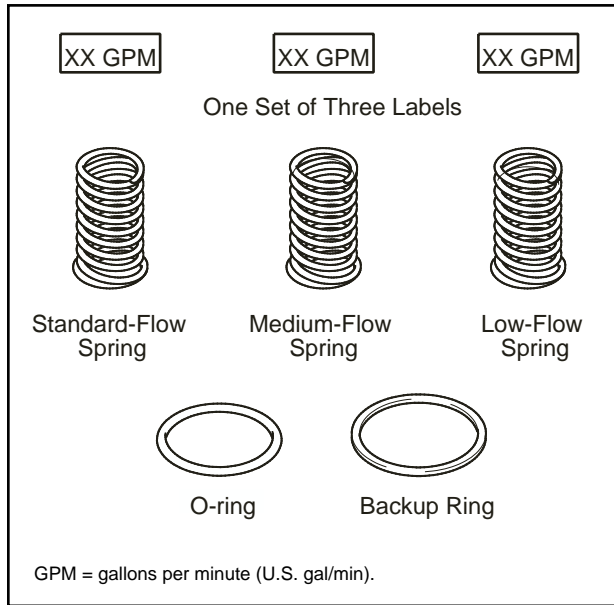

Maintenance

Disassembly

1. Remove the excess flow valve from the system.
2. Separate the inlet body from the outlet body.

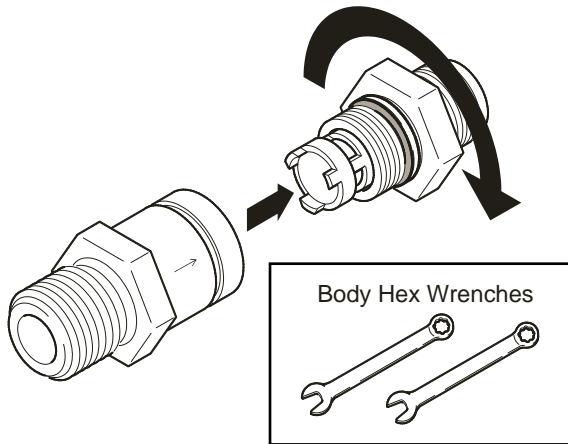

Outlet Body

3. Remove the poppet.

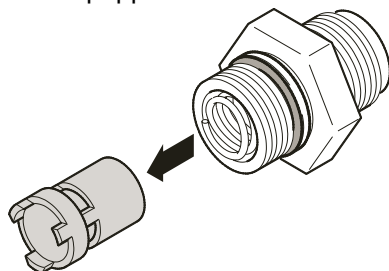

4. Remove the spring.

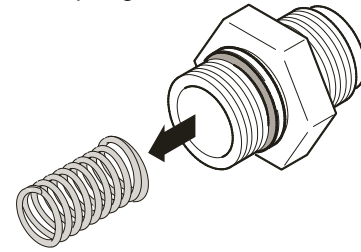

5. Remove the O-ring.

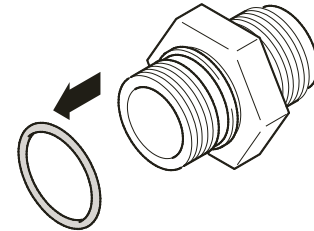

6. Remove the backup ring.

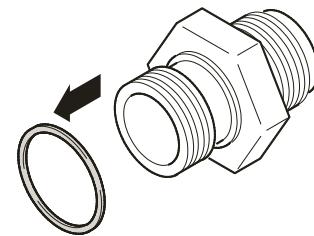

Inlet Body

7. Remove the identification ring.

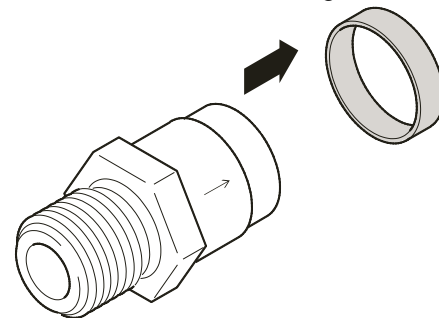

Reassembly

Outlet Body

1. Place the backup ring on the outlet body.

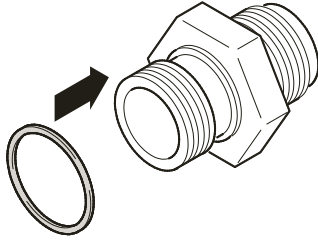

2. Lubricate the O-ring with a compatible lubricant.

3. Slide the O-ring over the threads against the backup ring.

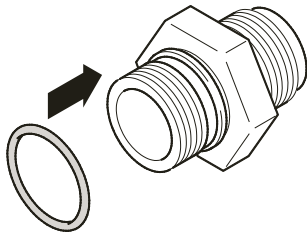

4. Select the preferred replacement spring from the table below.

Nominal End Connection Size	Spring		
	Nominal Flow, U.S. gal/min (L/min)		
	Standard Flow	Medium Flow	Low Flow
1/8 in. 1/4 in. 6 mm	XS4	XS4-3	XS4-1
	5 (18.9)	3 (11.3)	1 (3.7)
3/8 in. 8 mm	XS6	XS6-6	XS6-3
	9 (34.0)	6 ((22.7)	3 (11.3)
1/2 in. 12 mm	XS8	XS8-6	XS8-3
	13 (44.2)	6 (22.7)	3 (11.3)

5. Insert the spring, large end first, into the body.

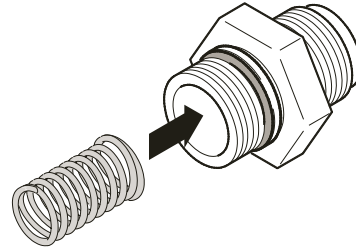

6. Insert the poppet over the spring.

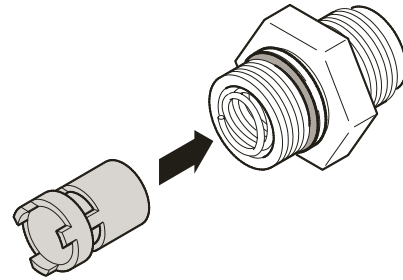

7. Lubricate the body threads with a system-compatible lubricant

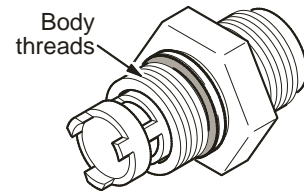

Inlet Body

8. Place the identification ring on the body.

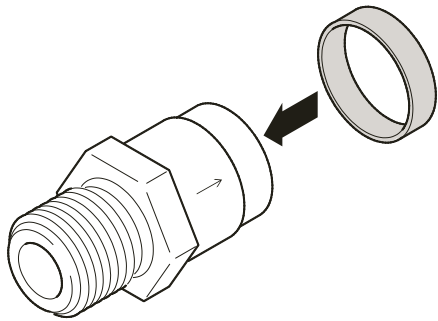

9. Select the trip point label that matches the replacement spring. Place the label on the identification ring.

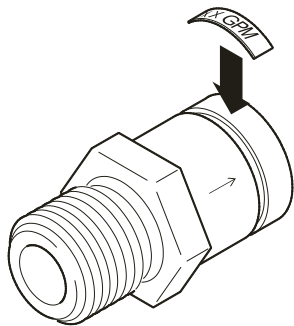

10. Thread the outlet and inlet bodies together.

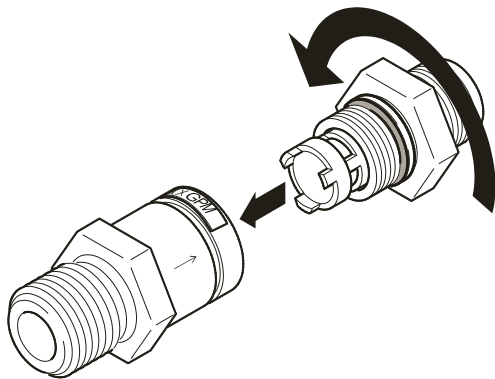

Notice:

Do not pinch the O-ring and backup ring between the outlet and the inlet bodies during assembly.

The O-ring must fit tightly into the inlet body.

11. Tighten the valve bodies.

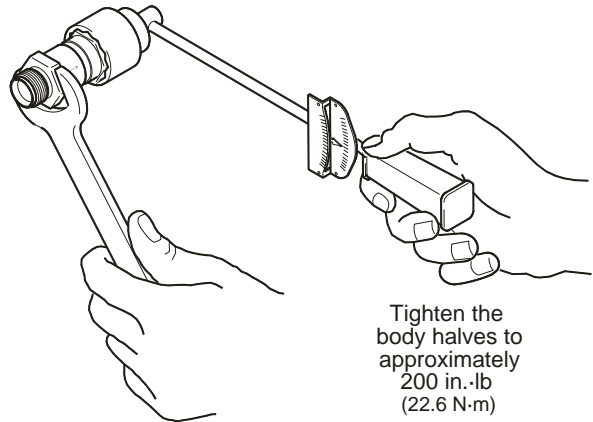

Tighten the body halves to approximately 200 in.-lb (22.6 N·m)

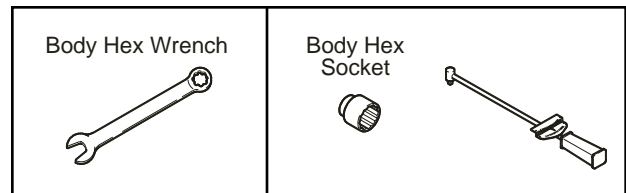

12. See **Installation** and **Testing** sections.

Troubleshooting

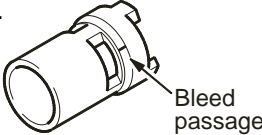
Symptom	Possible Causes	Corrective Action
Valve trips during normal operation	Flow surges higher than expected.	Evaluate a smaller valve. Evaluate a lower trip range spring option.
Valve trips at normal flow after being in service for some time.	Poppet openings are plugged.	Clean or replace poppet. Flush or blow down regularly. Clean on a regular preventive maintenance schedule.
Valve does not trip at high flow	Valve is too large.	Evaluate a smaller valve. Evaluate a lower trip range spring option.
	Low system pressure.	System pressure must be greater than trip pressure. Evaluate a lower trip range spring option.
	Poppet is stuck.	The parts are contaminated. Clean the parts thoroughly. Replace the damaged parts. Service regularly. The parts are corroded. Replace corroded parts. Select a compatible material.
Valve does not reset itself	Bleed passage on poppet is plugged. 	The parts are contaminated. Clean the parts thoroughly. Replace the damaged parts. Service regularly. The parts are corroded. Replace corroded parts. Select a compatible material.

Safe Product Selection

When selecting products, the total system design must be considered to ensure safe, trouble-free performance. Function, material compatibility, adequate ratings, proper installation, operation, and maintenance are the responsibilities of the system designer and user.

Caution: Do not mix or interchange parts with those of other manufacturers

VCR, VCO, Swagelok — TM Swagelok Co.
© 2000 Swagelok Company