

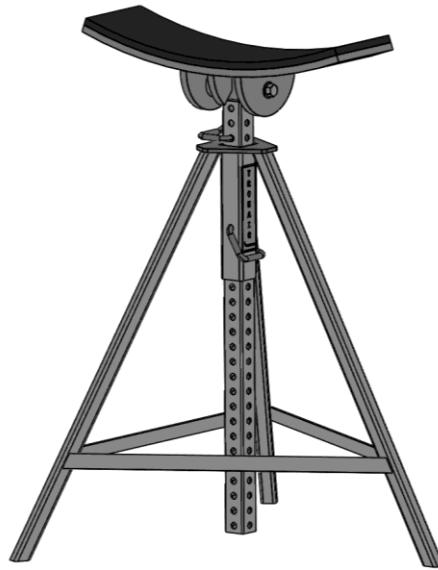

OPERATION & SERVICE MANUAL



**Model: 03-5851-0000
HondaJet Tailstand**



11/2015 – Rev. 01

REVISION
01

DATE
11/2015

TEXT AFFECTED
Original Release



TABLE OF CONTENTS

	<u>PAGE</u>
1.0 PRODUCT INFORMATION	1
1.1 DESCRIPTION.....	1
1.2 MODEL & SERIAL NUMBER.....	1
1.3 MANUFACTURER.....	1
1.4 FUNCTION.....	1
2.0 SAFETY INFORMATION.....	1
2.1 USAGE AND SAFETY INFORMATION.....	1
2.2 FUNCTIONAL SAFETY FEATURES.....	1
2.3 PERSONAL PROTECTION EQUIPMENT.....	1
2.4 SAFETY GUIDELINES.....	1
2.5 CONDITIONS FOR SAFE USE.....	1
2.6 ADDITIONAL SAFETY MEASURES.....	1
3.0 PREPARATION PRIOR TO FIRST USE	2
3.1 PRE-USE CHECKS.....	2
4.0 TRAINING.....	2
4.1 TRAINING REQUIREMENTS.....	2
4.2 TRAINING PROGRAM.....	2
4.3 OPERATOR TRAINING.....	2
5.0 OPERATION.....	2
5.1 OPERATING PARAMETERS.....	2
5.2 NUMERICAL VALUES.....	2
5.3 OPERATING INSTRUCTIONS.....	2
6.0 PACKAGING AND STORAGE.....	3
6.1 PACKAGING REQUIREMENTS.....	3
6.2 STRAPPING.....	3
6.3 LABELING OF PACKAGING.....	3
6.4 STORAGE ENVIRONMENT.....	3
6.5 STORAGE SPACE AND HANDLING FACILITIES.....	3
7.0 TRANSPORTATION.....	3
8.0 MAINTENANCE.....	3
8.1 GENERAL.....	3
8.2 MAINTENANCE SCHEDULE.....	3
8.3 JACK FUNCTION LOAD TEST.....	3
8.4 INSPECTION AND TEST PROCEDURES.....	3
9.0 PROVISION OF SPARES.....	4
9.1 SOURCE OF SPARE PARTS.....	4
9.2 RECOMMENDED SPARE PARTS LISTS.....	4
10.0 IN-SERVICE SUPPORT.....	4
11.0 GUARANTEES/LIMITATION OF LIABILITY.....	4
12.0 APPENDICES.....	4

This product can not be modified without the written approval of Tronair, Inc. Any modifications done without written approval voids all warranties and releases Tronair, Inc., its suppliers, distributors, employees, or financial institutions from any liability from consequences that may occur. Only Tronair OEM replacement parts shall be used.

1.0 PRODUCT INFORMATION

1.1 DESCRIPTION

Tailstand, 1,500 lbs (680 kg) capacity, CE compliant

1.2 MODEL & SERIAL NUMBER

Reference nameplate on unit

1.3 MANUFACTURER

TRONAIR, Inc.
1 Air Cargo Pkwy East
Swanton, Ohio 43558 USA

Telephone: (419) 866-6301 or 800-426-6301
Fax: (419) 867-0634
E-mail: sales@tronair.com
Website: www.tronair.com

1.4 FUNCTION

The device is intended to stabilize an aircraft by its fuselage during maintenance, whose maximum load does not exceed the rated capacity of the tailstand.

2.0 SAFETY INFORMATION

2.1 USAGE AND SAFETY INFORMATION

To insure safe operations please read the following statements and understand their meaning. Also refer to your equipment manufacturer's manual for other important safety information. This manual contains safety precautions which are explained below. Please read carefully.



WARNING! — Warning is used to indicate the presence of a hazard that **can cause severe personal injury, death, or substantial property damage** if the warning notice is ignored.

CAUTION! — Caution is used to indicate the presence of a hazard that **will or can cause minor personal injury or property damage** if the caution notice is ignored.

2.2 FUNCTIONAL SAFETY FEATURES

Cautions and Instruction Labels located on tailstand

2.3 PERSONAL PROTECTION EQUIPMENT



CAUTION!
Always wear safety glasses.

2.4 SAFETY GUIDELINES



CAUTION!

1. **DO NOT** place hands on top of tailstand while lowering tailstand adjusting tube. Pinch point exists between top of inner and outer tubes.
2. **DO NOT** place feet under tailstand while lowering tailstand adjusting tube. Pinch point exists between ground and adjusting tube.
3. **ALWAYS** install tailstand **AFTER** aircraft has been jacked to working position.
4. **Never** put hands between aircraft and tailstand saddle.
5. **ALWAYS** be sure tailstand adjusting tube pin is fully inserted and seated around tubing.
6. **NEVER** load tailstand by lowering jacks. **ALWAYS** lower tailstand and remove same **BEFORE** lowering aircraft.

2.5 CONDITIONS FOR SAFE USE

- Use in a clean dry environment on a hard level surface.
- Operate between -20° C and 50°C/-4° F and 122° F.

2.6 ADDITIONAL SAFETY MEASURES

This tailstand must be used in accordance with this Operation manual, and in accordance with the aircraft manufacturer's jacking and stabilizing procedures.

3.0 PREPARATION PRIOR TO FIRST USE**3.1 PRE-USE CHECKS**

1. Refer to the Illustrated Parts List identify and ensure that all parts are present.
2. Generally check over unit to assure the tightness of all nuts and bolts.

4.0 TRAINING**4.1 TRAINING REQUIREMENTS**

Training of operating personnel is the responsibility of the employer. This tailstand must be used in accordance with aircraft manufacturer's instructions.

This tailstand is intended to be used by a skilled and trained aircraft technician. The operator must be familiar with the jacking procedures for the aircraft to be raised, and the operation of the tailstand.

4.2 TRAINING PROGRAM

The employer provided operator training program should cover safety procedures concerning use of the unit in and around the intended aircraft at the intended aircraft servicing location.

4.3 OPERATOR TRAINING

The operator training should provide the required training for safe operation of the unit.

NOTE: Installation, Maintenance and Trouble Shooting are to be performed by a skilled and trained technician.

5.0 OPERATION**5.1 OPERATING PARAMETERS**

1. The user shall work in accordance with this Operator and Service
2. The employer of the operator shall provide all necessary training
3. Operate between -20° C and 50° C/-4° F and 122° F

5.2 NUMERICAL VALUES

- Rated Capacity: 1,500 lbs (680 kg)
- Minimum Closed Height: 34 ⁵/₈ in (87.95 cm)
- Maximum Height Obtainable: 55 in (139.7 cm)
- Weight: 30 lbs (13.6 kg)

5.3 OPERATING INSTRUCTIONS

The user should be familiar with the following statements prior to using the tailstand:

CAUTION!

1. **DO NOT** place hands on top of tailstand while lowering tailstand adjusting tube. Pinch point exists between top of inner and outer tubes.
2. **DO NOT** place feet under tailstand while lowering tailstand adjusting tube. Pinch point exists between ground and adjusting tube.
3. **ALWAYS** install tailstand **AFTER** aircraft has been jacked to working position.
4. **Never** put hands between aircraft and tailstand saddle.
5. **ALWAYS** be sure tailstand adjusting tube pin is fully inserted and seated around tubing.
6. **NEVER** load tailstand by lowering jacks. **ALWAYS** lower tailstand and remove same **BEFORE** lowering aircraft.

5.3.1 Rules For Operating

1. The user shall work in accordance with this Operator and Service Manual
2. The employer of the operator shall provide all necessary training
3. Operate between -20° C and 50°C/-4° F and 122° F

5.3.2 To Raise Aircraft

1. Jack aircraft to desired height.
2. Place tailstand on a hard, level surface.
3. Position tailstand at aircraft manufacturer's recommended location.
4. Raise tailstand saddle as close to aircraft as possible.
5. Install tailstand adjusting tube pin and seat around tubing.

5.3 Operating instructions continued on following page.



5.3 OPERATING INSTRUCTIONS *(continued)*

5.3.3 To Lower Aircraft

1. Clear all personnel from inside and under aircraft.
2. Remove tailstand adjusting tube pin and lower extension.
3. Relocate tailstand away from aircraft and secure.
4. Lower aircraft to the ground.

6.0 PACKAGING AND STORAGE

6.1 PACKAGING REQUIREMENTS

Tailstand is to be packaged as required to prevent damage to legs or saddle during shipment.

6.2 STRAPPING

Tailstand can be strapped down by suitable means to prevent unwanted movement during shipment.

6.3 LABELING OF PACKAGING

Packaging should be labeled **DO NOT DROP**.

6.4 STORAGE ENVIRONMENT

- Store tailstand between -20° C and +50° C/-4° F and 122° F
- Always store tailstand with extension all the way down
- Suitable for outdoor storage by using a full coverage waterproof tarp or canvas

6.5 STORAGE SPACE AND HANDLING FACILITIES

- Minimum Closed Height: 34 5/8 in (87.95 cm)
- Maximum Height Obtainable: 55 in (139.7 cm)
- Weight: 30 lbs (13.6 kg)
- Footprint: 32 5/16 in (82 cm) diameter

7.0 TRANSPORTATION

Lifting can be accomplished by crane and strap through top of tripod, or by fork truck under lower tripod support. Approximate weight 30 lbs (13.6 kg).

8.0 MAINTENANCE

8.1 GENERAL

- All maintenance and/or repair work should be done using good workmanship practices and proper tools
- Tailstand shall be maintained and repaired in accordance with the manufacturer's instructions. Such maintenance and repair shall be carried out by qualified persons
- No modifications shall be carried out as they may adversely affect the compliance of the tailstand with draft standard 2006/42/EC

8.2 MAINTENANCE SCHEDULE

Saddle.....Annually or as Needed

Cleaning.....Annually or as Needed

NOTE: Wipe with soft cloth only, do not pressure wash or spray water directly at saddle.

8.3 JACK FUNCTION LOAD TEST

NOTE: If function load testing is required:

- Take all necessary precautions to prevent injury.
- Do not exceed a test load equal to 110% of the tailstand rated capacity.

8.4 INSPECTION AND TEST PROCEDURES

Visually inspect all welds, saddle, pin, and pin holes in the base and adjusting tube for defects. If defects are found, remove tailstand from active service until repairs are made.



9.0 PROVISION OF SPARES

9.1 SOURCE OF SPARE PARTS

Spare parts may be obtained from the manufacturer:

TRONAIR, Inc.	Telephone: (419) 866-6301 or 800-426-6301
1 Air Cargo Pkwy East	Fax: (419) 867-0634
Swanton, Ohio 43558 USA	E-mail: sales@tronair.com
	Website: www.tronair.com

9.2 RECOMMENDED SPARE PARTS LISTS

Reference the following page(s) for Replacement Parts and Kits available.

Recommended Spares to be kept on hand:

G-1311-01 Pin, Leg Hook

10.0 IN-SERVICE SUPPORT

Contact Tronair, Inc. for technical services and information. See Section 1.3 – Manufacturer.

11.0 GUARANTEES/LIMITATION OF LIABILITY

Tronair products are warranted to be free of manufacturing or material defects for a period of one year after shipment to the original customer. This is solely limited to the repair or replacement of defective components. This warranty does not cover the following items:

- a) Parts required for normal maintenance
- b) Parts covered by a component manufacturers warranty
- c) Replacement parts have a 90-day warranty from date of shipment

If you have a problem that may require service, contact Tronair immediately. Do not attempt to repair or disassemble a product without first contacting Tronair, any action may affect warranty coverage. When you contact Tronair be prepared to provide the following information:

- a) Product Model Number
- b) Product Serial Number
- c) Description of the problem

If warranty coverage is approved, either replacement parts will be sent or the product will have to be returned to Tronair for repairs. If the product is to be returned, a Return Material Authorization (RMA) number will be issued for reference purposes on any shipping documents. Failure to obtain a RMA in advance of returning an item will result in a service fee. A decision on the extent of warranty coverage on returned products is reserved pending inspection at Tronair. Any shipments to Tronair must be shipped freight prepaid. Freight costs on shipments to customers will be paid by Tronair on any warranty claims only. Any unauthorized modification of the Tronair products or use of the Tronair products in violation of cautions and warnings in any manual (including updates) or safety bulletins published or delivered by Tronair will immediately void any warranty, express or implied.

The obligations of Tronair expressly stated herein are in lieu of all other warranties or conditions expressed or implied. **Any unauthorized modification of the Tronair products or use of the Tronair products in violations of cautions and warnings in any manual (including updates) or safety bulletins published or delivered by Tronair will immediately void any warranty, express or implied and Tronair disclaims any and all liability for injury (WITHOUT LIMITATION and including DEATH), loss or damage arising from or relating to such misuse.**

12.0 APPENDICES

APPENDIX I Declaration of Conformity

Parts List

When ordering replacement parts/kits, please specify model, serial number and color of your unit.

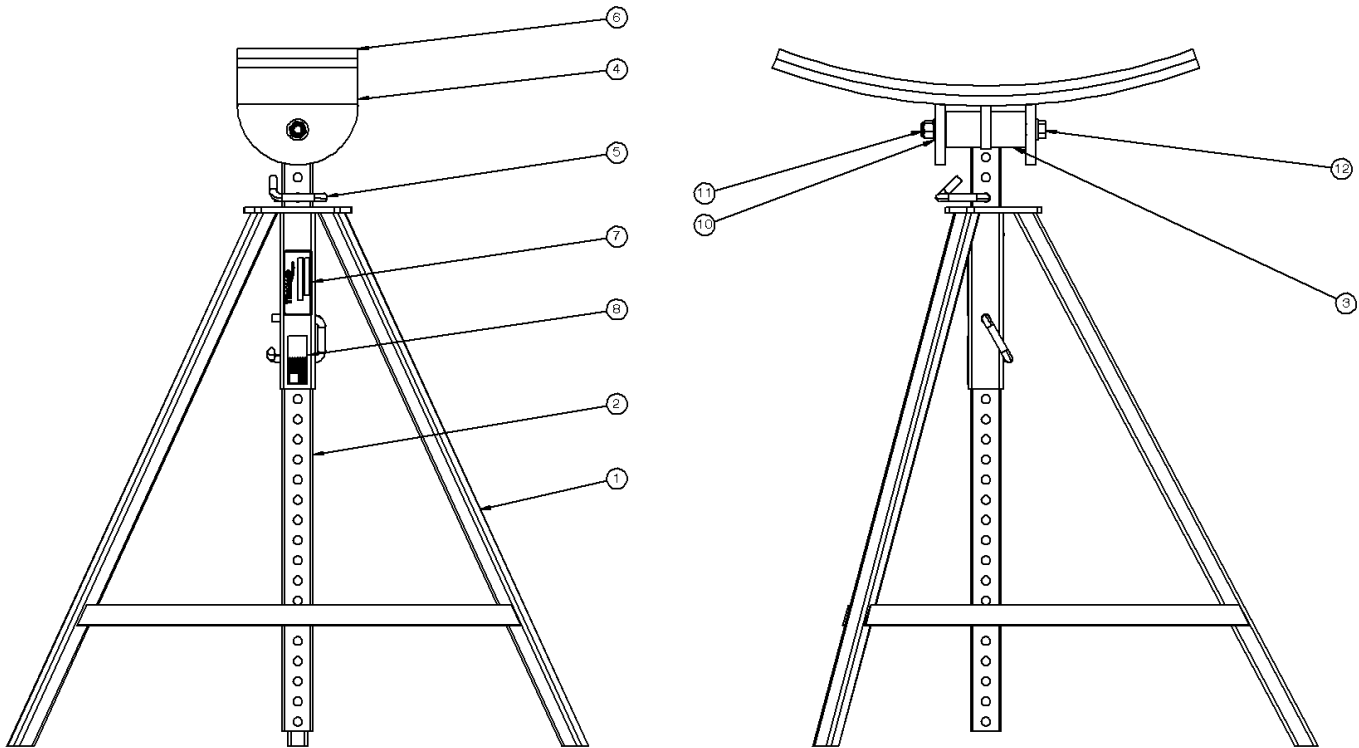

Item	Part Number	Description	Qty
1	Z-8956-01	Weldment, Tripod	1
2	TS-2615-01	Tube, Adjusting	1
3	Z-8955	Weldment, Swivel	1
4	Z-8953	Weldment, Saddle	1
5	G-1311-01	Pin, Leg Hook	1
6	H-1611-60-21.0	Pad, Neoprene	1
7	V-1003	Label, Serial Number	1
8	V-1001	Label, Made In USA	1
10	G-150-1090N	Flatwasher, 1/2 Narrow	2
11	G-1202-1090	Stopnut, 1/2 - 13 Elastic	1
12	G-1100-109060	Bolt, Hex Head Grade 5, 1/2 - 13 x 6 Long	1
Not Shown	V-1198	Label, Tronair	1



APPENDIX I

Declaration of Conformity



DECLARATION of CONFORMITY

The design, development and manufacture is in accordance with European Community guidelines

HONDAJET TAILSTAND
03-5851-0000

Relevant provisions complied with by the machinery:
2006/42/EC

Relevant standards complied with by the machinery:
EN ISO 12100-1

Identification of person empowered to sign on behalf of the Manufacturer:

A handwritten signature in black ink that reads "Patrick Finch". The signature is written in a cursive, flowing style. Below the signature is a solid horizontal line that spans the width of the signature.

Quality Assurance Representative