



OPERATION & SERVICE MANUAL



Model: 175S-2 (17500S-2)
Universal Wheel/Brake Changer

06/2024 – Rev. 04

For Spare Parts, Operations & Service Manuals or Service Needs
Scan the QR code or visit Tronair.com/aftermarket

The Tronair Group of Companies: Tronair | EBIS | Columbus Jack | Eagle | DAE | Malabar International

Malabar International

1 Air Cargo Pkwy East
Swanton, OH 43558

Phone: (419) 866-6301 | 800-426-6301

Web: www.malabar.com
Email: sales@malabar.com

REVISION	DATE	TEXT AFFECTED
01	10/2018	Original release
02	10/2022	Modified Parts List
03	11/2023	Modified Parts List
04	06/2024	Modified Parts List



TABLE OF CONTENTS

PAGE

1.0	PRODUCT INFORMATION	1
1.1	DESCRIPTION.....	1
1.2	MODEL & SERIAL NUMBER.....	1
1.3	MANUFACTURER.....	1
1.4	SPECIFICATIONS	1
2.0	SAFETY INFORMATION.....	1
2.1	USAGE AND SAFETY INFORMATION.....	1
3.0	PREPARATION PRIOR TO FIRST USE	1
4.0	TRAINING.....	2
4.1	TRAINING REQUIREMENTS	2
4.2	TRAINING PROGRAM	2
4.3	OPERATOR TRAINING.....	2
5.0	OPERATION.....	2
5.1	PRE OPERATION INSPECTION.....	2
5.2	OPERATING INSTRUCTIONS	2
6.0	MAINTENANCE.....	3
6.1	SERVICING	3
6.2	INSPECTION	3
6.3	REPAIR AND REPLACEMENT	3
7.0	PROVISION OF SPARES.....	4
7.1	SOURCE OF SPARE PARTS.....	4
7.2	RECOMMENDED SPARE PARTS LISTS	4
8.0	IN SERVICE SUPPORT.....	4
9.0	GUARANTEES/LIMITATION OF LIABILITY	4



This product can not be modified without the written approval of Tronair, Inc. Any modifications done without written approval voids all warranties and releases Tronair, Inc., its suppliers, distributors, employees, or financial institutions from any liability from consequences that may occur. Only Tronair OEM replacement parts shall be used.



CAUTION!

Aircraft manufacturer's specifications and instructions must be followed. In the event of contradiction between aircraft manufacturer's specifications and Malabar's, aircraft manufacturer's will prevail.

1.0 PRODUCT INFORMATION

1.1 DESCRIPTION

The Malabar Universal Wheel/Brake Changer Model 175S-2 is capable of changing aircraft tires and wheel assemblies from 32 to 56 in (81 to 142 cm) O.D. and widths to 22 in (56 cm). The Boom or Brake Cradle (BC300, BC400, BC500) is required for brake change operations. The Universal Wheel/Brake Changer consists of a Hydraulic Hand Pump, Hydraulic Cylinder, Foam Filled Swivel Lock Casters, Foam Filled Swivel Lock Caster with Brake, Towbar, Inner and Outer Frames, Boom, Flow Control Valve, Storage Box, Wheel Hold Down steel Chain and Tie Down Straps.

1.2 MODEL & SERIAL NUMBER

Reference nameplate on unit

1.3 MANUFACTURER

Tronair / Malabar International
1 Air Cargo Pkwy East
Swanton, Ohio 43558 USA

Telephone: (419) 866-6301 or 800-426-6301
E-mail: sales@malabar.com
Website: www.malabar.com
Website: www.tronair.com

1.4 SPECIFICATIONS

Wheel Changer Rated Capacity	700 lb (318 kg)
Boom Rated Capacity	500 lb (227 kg)
Total Lift.....	26 in (660 mm)
Estimate Weight.....	500 lb (227 kg)
Estimate Shipping Weight	620 lb (281 kg)
Ground Clearance	4 in (102 mm)
Proof Load (Wheel Changer)	900 lb (409 kg)
Proof Load (Boom)	750 lb (340 kg)
Standard Paint	Skydrol Resistant Yellow
Hand Pump Pop-off Valve Set at.....	3600 psig (253 kg/sq cm)
Reservoir Capacity	25 cu in (0.4 liter)
Hydraulic Fluid	MIL-PRF-5606 or equivalent
Maximum Towing Speed.....	5 mph (8 km/h)

2.0 SAFETY INFORMATION

2.1 USAGE AND SAFETY INFORMATION

To insure safe operations please read the following statements and understand their meaning. Also refer to your equipment manufacturer's manual for other important safety information. This manual contains safety precautions which are explained below. Please read carefully.



WARNING!

Warning is used to indicate the presence of a hazard that can cause **severe personal injury, death, and/or substantial property damage** if the Warning Notice is ignored.



CAUTION!

Caution is used to indicate the presence of a hazard, which will or can cause **minor personal injury or property damage** if the Caution Notice is ignored.

3.0 PREPARATION PRIOR TO FIRST USE

The Wheel/Brake Changer is shipped fully assembled. Hand pump reservoir is shipped with MIL-PRF- 5606 hydraulic fluid. Check hand pump reservoir fluid level at the fill port before operating the hand pump by removing the 1/4 NPT breather and 1/4 NPT 90° elbow located on top of the hand pump reservoir. The fluid level can be checked by dipping a clean stick (not included) through the fill port. The fluid level should be approximately 3 inches below the reservoir top and can only be checked with the inner frame in the full down position. The steel chain and tie-down straps are always required when transporting an aircraft wheel.

4.0 TRAINING

4.1 TRAINING REQUIREMENTS

The employer of the operator is responsible for providing a training program sufficient for the safe operation of the unit.

4.2 TRAINING PROGRAM

The employer provided operator training program should cover safety procedures concerning use of the unit in and around the intended aircraft at the intended aircraft servicing location.

4.3 OPERATOR TRAINING

The operator training should provide the required training for safe operation of the unit.

NOTE: Maintenance and Trouble Shooting are to be performed by a skilled and trained technician.

5.0 OPERATION

5.1 PRE OPERATION INSPECTION

Each time the wheel/brake changer is to be used, inspect the following:

1. Check the structure for rigidity. Make sure all bolts are tightened.
2. Check for oil leaks around the hand pump, hydraulic fittings, hydraulic hose and hydraulic cylinder.

5.2 OPERATING INSTRUCTIONS

1. FOR B757 WHEEL CHANGE OPERATIONS ONLY:
Extend two Wheel Backrest Arms (see figure 2, item 24) and switch two trailing casters (see figure 2, items 5 & 6) to narrow position (see figure 2, placard item 27).
2. FOR ALL AIRCRAFT EXCEPT B757 WHEEL CHANGE OPERATIONS: Retract Wheel Backrest Arms and switch two trailing casters to wide position.
3. The Boom can be used for brake change operations:
 - a. Place boom in socket located in the middle of the wheel backrest.
 - b. Fit sling in the Boom hook.
 - c. Approach brake assembly with Brake Changer and place brake assembly securely in sling.
 - d. Lift Boom to allow removal of brake assembly.
 - e. Pull Brake Changer to remove brake assembly from its installed position.
 - f. Lower Boom to the point of safe transport of the brake assembly.
 - g. Maneuver to brake assembly storage area and lower Boom until brake assembly can be safely removed.
 - h. To install the replacement brake assembly reverse above instructions.
 - i. The boom is to be stored in the boom storage socket during aircraft wheel change operations (see figure 2).

Alternatively, removal of brake assemblies can be accomplished using the optional Brake Cradles which can be mounted on the wheel rollers.

4. To raise the load:
 - a. Close release valve located at the side of the hand pump.
 - b. Operate the hand pump handle to raise the load to a desired position.
 - c. Do not raise a load greater than the rated capacity of 700 lb (317.5 kg) for the wheel changer or 500 lb (226.8 kg) for the boom.
 - d. Do not raise the inner frame more than 26 in (66 cm).
 - e. Keep the release valve closed when the inner frame is raised.
5. To lower the load:
 - a. Open the release valve located at the side of the hand pump to lower the load. The lowering speed is controlled by the flow control valve.
 - b. The flow control valve is connected between the hand pump and the hydraulic cylinder and is preset at the factory. The valve allows free flow in raising direction and restricted flow in lowering direction to control the rate of lowering. If adjustment is required, loosen the jam nut and turn the adjustment screw until desired lowering speed is achieved. Retighten the jam nut after adjustment.



CAUTION!

Always use steel chain and tie-down straps to securely tie down the aircraft wheel. To prevent damage to aircraft wheel hub, chain and straps should never contact wheel hub.

5.2 OPERATING INSTRUCTIONS *(continued)*

6. Procedure to tie down aircraft wheel (see figure 1):
 - a. Remove chain from storage box. Attach chain to one chain snap located on inner frame. Position chain above the final chain position. Pull chain slightly (while maintaining position) and connect chain to the opposite chain snap.
 - b. Remove tie-down straps (2 pieces) from storage box. Connect both straps to lower roller links and chain as shown. Straps should be placed at appropriate chain link to clear wheel hub.
 - c. Alternately tighten each tie-down strap until chain tightens. Chain should be located at final chain position. Chain and straps must not contact wheel hub after tightening.
7. Ground clearance for towing is 4 inches. Maximum towing speed is 5 mph. Do not tow with load on boom. When towing with a wheel & tire assembly, make sure the tire is at least 4 in (10 cm) and not more than 8 in (20 cm) above the ground.



Figure 1
Aircraft Wheel Tie Down in Transport Position



CAUTION!

Failure to lock swivel casters when towing will cause premature wearing of casters and unsafe towing conditions.

8. Unlock swivel casters during aircraft service, lock casters only when towing.
9. For aircraft service (installation or removal of wheel & brake) always remove the unit towbar and store at location provided on the outer frame (see figure 2). Towbar should be replaced for towing operations.
10. Ball lock pins must be engaged at all times.
11. The steel chain and tie-down straps should be stored in the storage box when not in use.

6.0 MAINTENANCE

6.1 SERVICING

Servicing the wheel/brake changer consists primarily of the following:

1. When in use, the hand pump reservoir should be kept at the proper level with hydraulic fluid MIL-PRF-5606 or approved equivalent.
2. Grease the swivel casters.
3. Casters are foam filled. Do not attempt to inflate.

6.2 INSPECTION

Each time the wheel/brake changer is to be used, inspect the following:

1. Check the structure for rigidity. Make sure all bolts are tightened.
2. Check for oil leaks around the hand pump, hydraulic fittings, hydraulic hose and hydraulic cylinder.

6.3 REPAIR AND REPLACEMENT

No definite time schedule can be established for the overhaul of the wheel/brake changer for replacement of the various moving parts. The number of times raised and the amount of load applied at each operation materially affect the life of the working parts. Do not overload the wheel/brake changer. Overloading is dangerous, will hasten the need for overhaul and may damage the wheel/brake changer. During overhaul, replace all parts that do not pass disassembly inspection requirements. To reorder parts, see figures 2 & 3 for parts breakdown.



7.0 PROVISION OF SPARES

7.1 SOURCE OF SPARE PARTS

Spare parts may be obtained from the manufacturer:

Tronair / Malabar International

1 Air Cargo Pkwy East
Swanton, Ohio 43558 USA

Telephone: (419) 866-6301 or 800-426-6301

E-mail: sales@malabar.com

Website: www.malabar.com

Website: www.tronair.com

For Spare Parts, Operations & Service Manuals or Service Needs:

Scan the QR code or visit Tronair.com/aftermarket

7.2 RECOMMENDED SPARE PARTS LISTS

Reference the following page(s) for Replacement Parts and Kits available.

8.0 IN SERVICE SUPPORT

Contact Malabar, Inc. for technical services and information.

See Section 1.3 – Manufacturer.

9.0 GUARANTEES/LIMITATION OF LIABILITY

- I. Seller warrants each new product of its manufacture to be free from defects in material or workmanship, under proper, reasonable, and normal use and service.
- II. The warranty period shall be as follows:
 - A. For Malabar equipment, with the exception of Tripod Jacks, the warranty period is one (1) year after date of shipment.
 - B. For Malabar Tripod Jacks, the warranty period is three (3) years after date of shipment.
- III. Where Buyer claims an alleged defect in material or workmanship and so advises Seller in writing within ten (10) days after discovery thereof, then and in such event, Buyer shall return said equipment, transportation prepaid, to the Seller, provided such return is timely and within the above-mentioned warranty period. This warranty and liability of the Seller is expressly limited solely to replacement or repair of defective parts or goods, and return at Buyer's expense to Buyer after finding by Seller the product was defective prior to original shipment or, at the option of Seller, to providing refund to Buyer of the purchase price for said product.
- IV. It is further expressly understood and agreed that:
 - A. THERE IS NO WARRANTY, REPRESENTATION OF ANY KIND, EXPRESS OR IMPLIED, (INCLUDING NO WARRANTY OF MERCHANTABILITY OR OF FITNESS) EXCEPT THAT THE MATERIAL SHALL BE OF THE QUALITY SPECIFIED IN APPLICABLE SPECIFICATIONS, AND NONE SHALL BE IMPLIED BY LAW. Except as otherwise provided herein, quality shall be in accordance with Seller's specifications. Final determination of the material for the use contemplated by Buyer is the sole responsibility of Buyer and Seller shall have no responsibility in connection with such suitability, and
 - B. Buyer's sole and exclusive remedy shall be repair or replacement of defective parts or goods by the Seller. Should the goods, in the judgment of Seller, preclude the remedying of the warranted defects by repair or replacement, the Buyer's sole and exclusive remedy shall be the refund of the purchase price, and
 - C. Seller shall not be liable for prospective profits or special, indirect or consequential damages, nor shall any recovery of any kind against Seller be greater in amount than the purchase price of the specific material sold and causing the alleged loss, damage or injury. Buyer assumes all risk and liability for loss, damage or injury to persons or property of Buyer or others arising out of use or possession of any product or part sold hereunder, and
 - D. Seller shall in no way be deemed or held to be obligated, liable or accountable upon or for any guarantees or warranties, express or implied, or created by statute or by operation of law or otherwise, in any manner of form beyond its express agreement above set forth, and
 - E. No warranty herein shall apply to any product which shall have been repaired or altered, unless such alteration or repair has been made by Seller or if, after return to and inspection by Seller, the product is found by Seller to have been subject to misuse, negligence or accident, and
 - F. No warranty of any nature is made by Seller as to any component forming a part of the product sold and Buyer shall receive only such warranties offered by such other manufacturer of such component, and
 - G. Seller does not assume nor does Seller authorize any other person to assume for it any other liability or make any warranty in connection with the sale of its products.

Parts List

When ordering replacement parts/kits, please specify model, serial number and color of your unit.

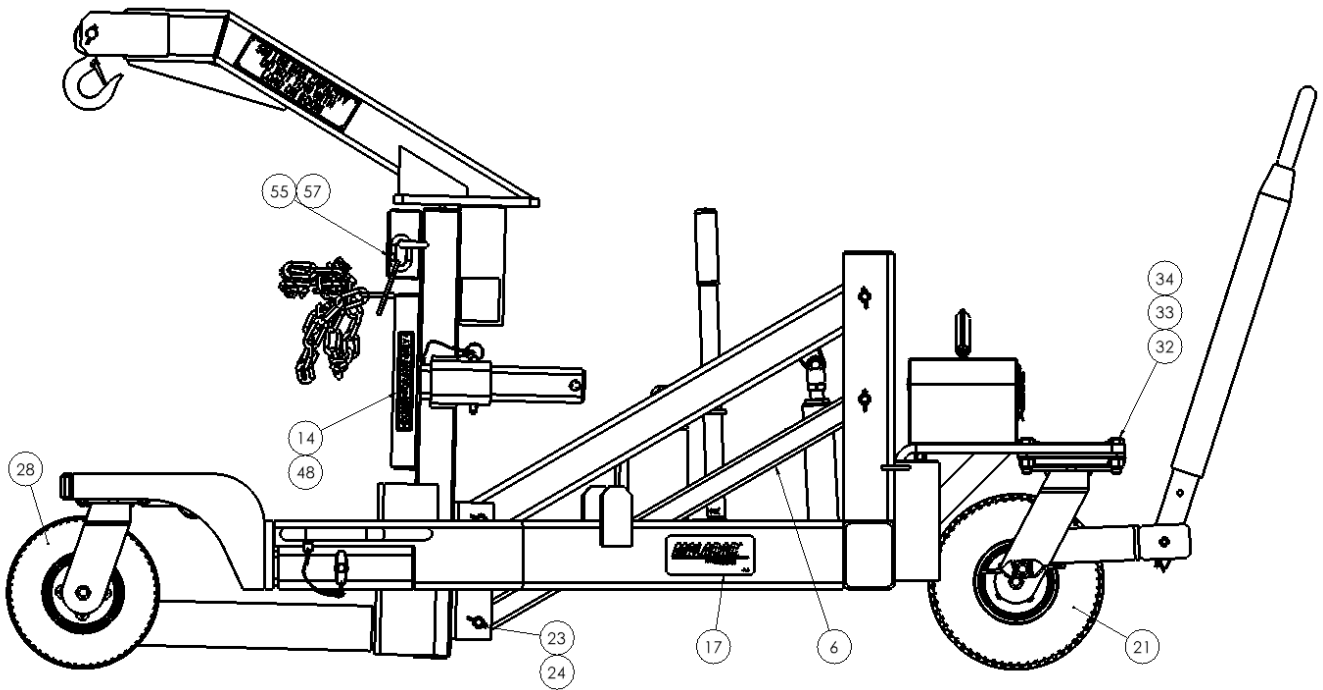
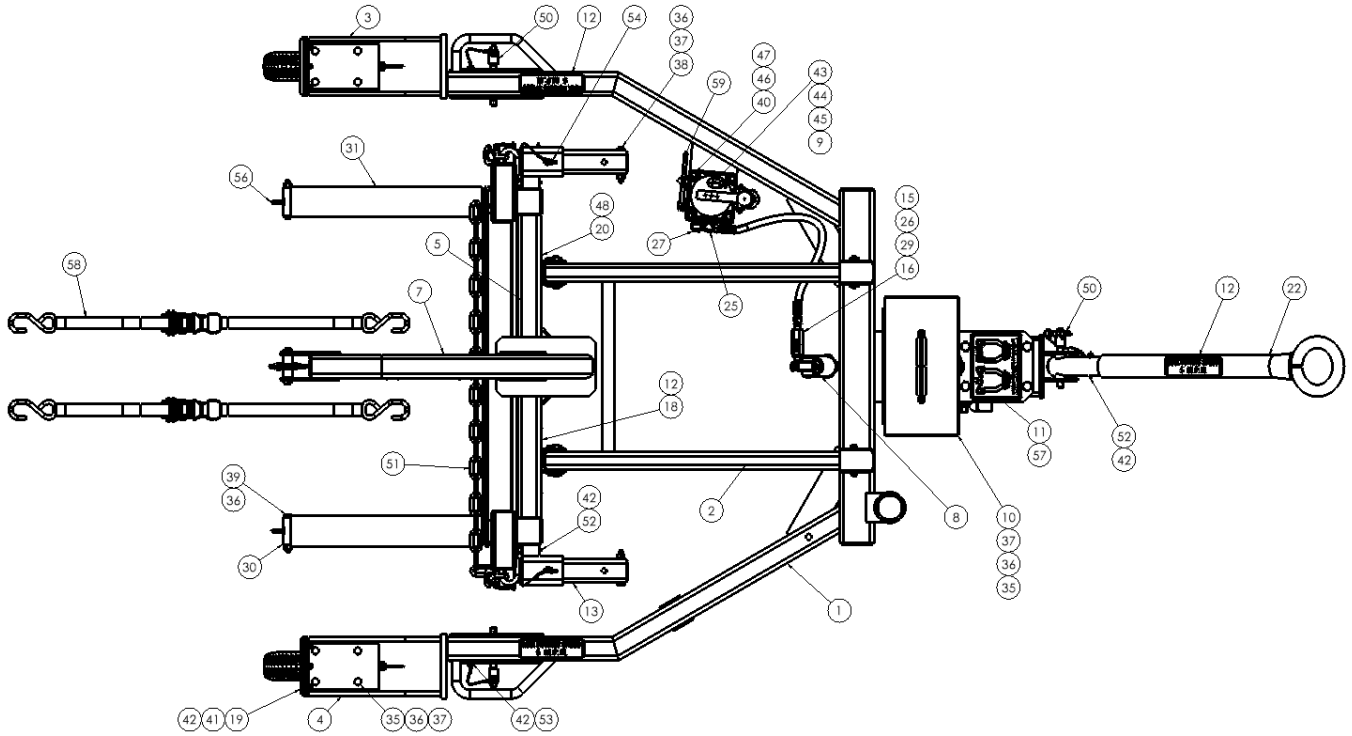

Parts List

When ordering replacement parts/kits, please specify model, serial number and color of your unit.

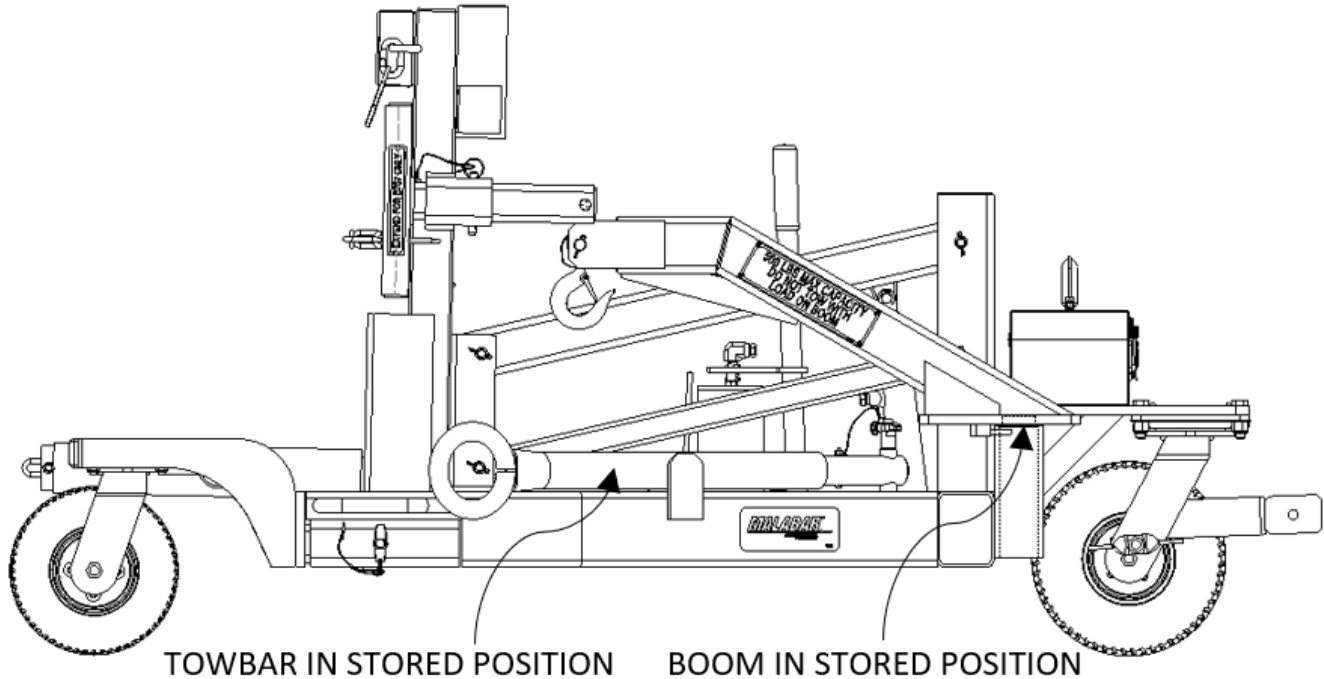

Item	Part Number	Description	Qty
1	17697	OUTER FRAME	1
2	17686	UPPER BEAM WELDMENT (WP)	1
3	17635	SWIVEL WHEEL PLATE WELDMENT, RIGHT	1
4	17636	SWIVEL WHEEL PLATE WELDMENT, LEFT	1
5	17681	INNER FRAME	1
6	17683	LOWER BEAM WELDMENT	2
7	17640	CRANE ASSEMBLY	1
8	426-021	HYDRAULIC CYLINDER	1
9	442-018	HAND PUMP	1
10	17753	STORAGE BOX	1
11	17625	PLACARD, WHEEL CHANGER	1
12	75940	STICKER, TOWING	3
13	177424	WHEEL BACKREST WELDMENT	2
14	17743	PLACARD, B757	2
15	712-022	ELBOW, 1/4 M NPT X 1/4 M NPT	1
16	422-054	FLOW CONTROL VALVE	1
17	55998	STICKER, MALABAR	2
18	17608	PLACARD	1
19	17756	BUMPER	2
20	55997-2	NAME PLATE	1
21	17752	MODIFIED FRONT CASTER	1
22	17631	TOW HANDLE	1
23	17691	PIN	8
24	372-023	COTTER PIN, 1/8 x 1" LG	16
25	723-047	TEE, 3/8 37° x 3/8 SAE x 3/8 37°	1

Item	Part Number	Description	Qty
25	723-047	TEE, 3/8 37° x 3/8 SAE x 3/8 37°	1
26	721-004	CONNECTOR, 3/8 37° x 1/4 MPT	1
27	717-032	CAP, 3/8 FEMALE 37°	1
28	492-137	FOAM FILLED SWIVEL LOCK CASTER	2
29	PF55557	HYDRAULIC HOSE	1
30	17507	RETAINING RING	2
31	17507A	WHEEL ROLLER ASSEMBLY	2
32	321-006	HHCS, 1/2-13 x 1-3/4 LG	4
33	362-005	FLAT WASHER, 1/2 SAE	4
34	G-1202-1090	STOPNUT, 1/2-13 ELASTIC	4
35	321-008	HHCS, 3/8-16 x 1-1/4 LG	12
36	355-001	HEX LOCKNUT, 3/8-16	16
37	362-003	FLAT WASHER, 3/8 SAE	18
38	321-223	HHCS, 3/8-16 X 2-3/4 LG	2
39	321-052	HHCS, 3/8-16 x 3" LG	2
40	321-095	HHCS, 1/4-28 X 2-1/2 LG	4
41	362-045	FLAT WASHER, #10	6
42	355-023	HEX LOCKNUT, 10-24	11
43	719-017	CONNECTOR, 1/4 M NPT X 1/4 F NPSM	1
44	712-008	ELBOW, 90°, 1/4 MPT x 1/4 FPT	1
45	483-005	BREATHER CAP, 1/4 MPT	1
46	362-001	FLAT WASHER, 1/4 SAE	4
47	355-007	LOCKNUT, 1/4-28	4
48	G-1352-08	RIVET, 1/8	12
49	MS21318-27	DRIVE SCREW #6 X 1/4"	4
50	370-029	QUICK RELEASE PIN	3
51	491-063-121.50	STRAIGHT LINK CHAIN (79 LINKS)	1
52	321-203	HHCS, #10-24 X 2" LG	3
53	321-199	HHCS, #10-24 X 1/2 LG	2
54	370-030	QUICK RELEASE PIN	2
55	491-064	CHAIN CONNECTOR	2
56	491-063	CHAIN, (1 LINK)	1
57	491-067	CHAIN SNAP	1
58	491-066	TIE DOWN STRAP, ONE PAIR	1
59	R-3392	ROUND, EXTENSION LEVER	1

Parts List

When ordering replacement parts/kits, please specify model, serial number and color of your unit.

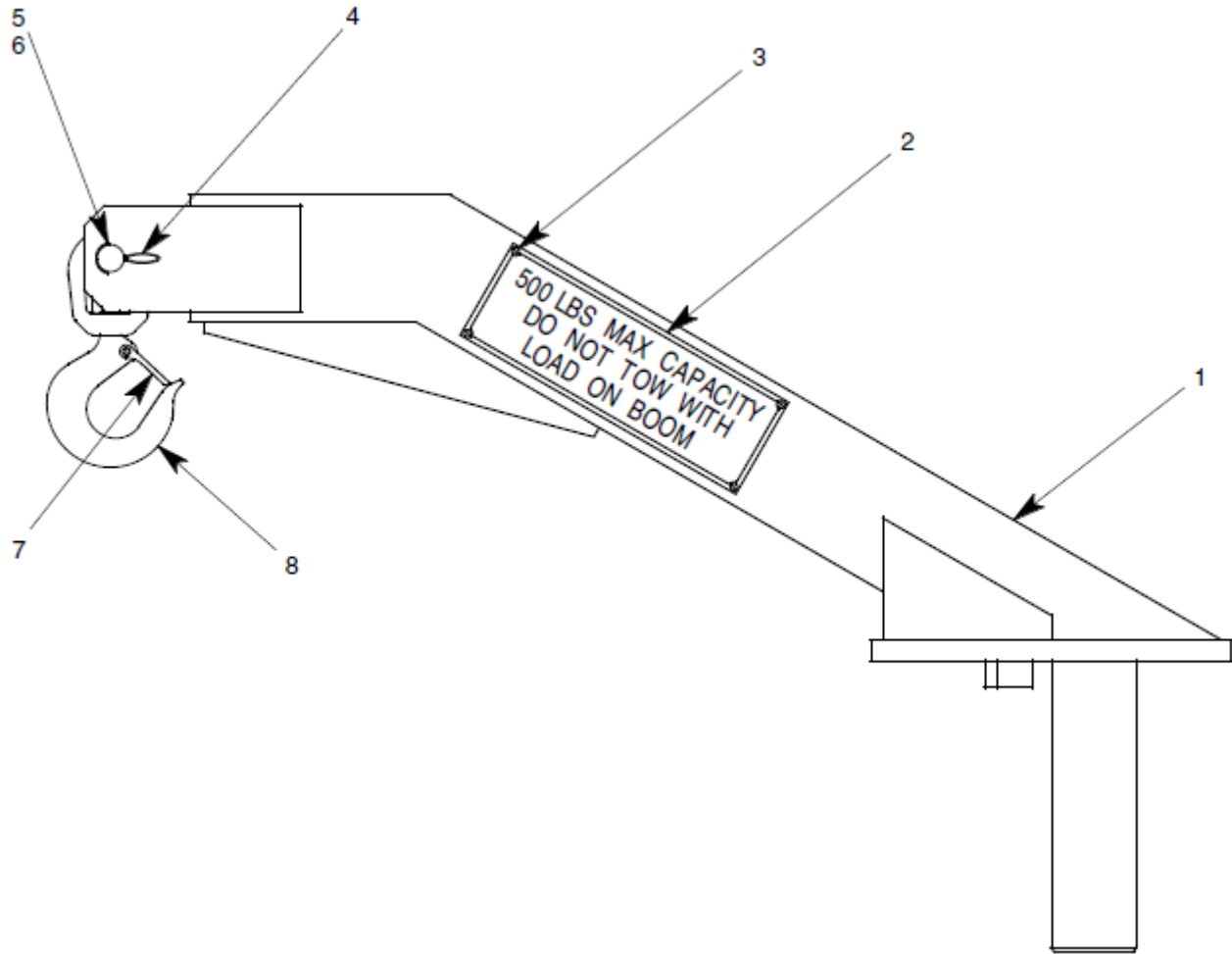

Item	Part Number	Description	Qty
	17640	Boom Assembly; consist of:	
1	17672	CRANE	1
2	17599	PLACARD	1
3	397-005	SELF TAPPING SCREW, #4	4
4	372-023	COTTER PIN, 1/8 x 1" LG	2
5	17556	PIN	1
6	17560	SPACER	1
7	491-058	LATCH	1
8	491-051	HOOK	1

OPTIONAL EQUIPMENT (MALABAR BRAKE CRADLES)

The Malabar Brake Cradle Models BC300, BC400 & BC500 or Models BC300P, BC400P & BC500P with saddle brake protection pads may be purchased separately for brake installation and removal.

