

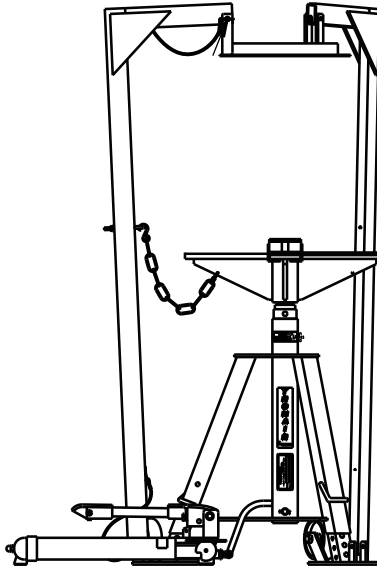

# OPERATION & SERVICE MANUAL



**Models: 14-6801-0120  
14-6801-0120SP  
Hydraulic Beadbreaker**



12/2021 – Rev. 03

REV	DATE	TEXT AFFECTED
OR	05/2001	Original release
01	04/2012	Modified Parts List
02	09/2017	Major revision
03	12/2021	Modified Parts List



**TABLE OF CONTENTS**

	<b><u>PAGE</u></b>
<b>1.0 PRODUCT INFORMATION .....</b>	<b>1</b>
1.1 DESCRIPTION.....	1
1.2 MODEL & SERIAL NUMBER.....	1
1.3 MANUFACTURER .....	1
1.4 TECHNICAL SPECIFICATIONS .....	1
<b>2.0 SAFETY INFORMATION .....</b>	<b>1</b>
2.1 USAGE AND SAFETY INFORMATION .....	1
<b>3.0 PREPARATION FOR USE .....</b>	<b>1</b>
<b>4.0 TRAINING .....</b>	<b>1</b>
4.1 TRAINING REQUIREMENTS .....	1
4.2 TRAINING PROGRAM .....	1
4.3 OPERATOR TRAINING .....	1
<b>5.0 OPERATION .....</b>	<b>2</b>
5.1 BOLTED/SPLIT WHEEL ASSEMBLIES .....	2
5.2 GOODYEAR WHEEL WITH DEMOUNTABLE FLANGE ( <i>Disassembly</i> ) .....	2
5.3 GOODYEAR WHEEL WITH DEMOUNTABLE FLANGE ( <i>Assembly</i> ) .....	3
<b>6.0 OPTIONAL TIRE RINGS .....</b>	<b>4</b>
<b>7.0 MAINTENANCE .....</b>	<b>4</b>
<b>8.0 PROVISION OF SPARES .....</b>	<b>4</b>
8.1 SOURCE OF SPARE PARTS.....	4
8.2 RECOMMENDED SPARE PARTS LISTS .....	4
<b>9.0 IN SERVICE SUPPORT .....</b>	<b>4</b>
<b>10.0 GUARANTEES/LIMITATION OF LIABILITY .....</b>	<b>5</b>
<b>11.0 APPENDICES .....</b>	<b>5</b>

This product can not be modified without the written approval of Tronair, Inc. Any modifications done without written approval voids all warranties and releases Tronair, Inc., its suppliers, distributors, employees, or financial institutions from any liability from consequences that may occur. Only Tronair OEM replacement parts shall be used.

## 1.0 PRODUCT INFORMATION

### 1.1 DESCRIPTION

The Tronair Hydraulic Beadbreaker 14-6801-0120 is an easy-to-use device for breaking the tire bead from rims. It is also a handy assembly tool that will reduce the tire side wall height while assembling the rim assembly.

This tire beadbreaker is especially suited for breaking down and building up the Goodyear forged aluminum wheel with de-mountable flange (split ring) currently used on the Sabre 65 and Grumman III aircraft.

### 1.2 MODEL & SERIAL NUMBER

Reference nameplate on unit

### 1.3 MANUFACTURER

**TRONAIR, Inc.**  
1 Air Cargo Pkwy East  
Swanton, Ohio 43558 USA

Telephone: (419) 866-6301 or 800-426-6301  
Fax: (419) 867-0634  
E-mail: sales@tronair.com  
Website: www.tronair.com

### 1.4 TECHNICAL SPECIFICATIONS

Construction .....All steel welded frame and members.  
Power Source.....2 ¼ ton hydraulic force; foot operated pump.  
Capacity .....Refer to section 6.0 Optional Tire Rings

## 2.0 SAFETY INFORMATION

### 2.1 USAGE AND SAFETY INFORMATION

To insure safe operations please read the following statements and understand their meaning. Also refer to your equipment manufacturer's manual for other important safety information. This manual contains safety precautions which are explained below. Please read carefully.



**WARNING!** — Warning is used to indicate the presence of a hazard that **can cause severe personal injury, death, or substantial property damage** if the warning notice is ignored.

**CAUTION!** — Caution is used to indicate the presence of a hazard that **will or can cause minor personal injury or property damage** if the caution notice is ignored.

## 3.0 PREPARATION FOR USE

1. Refer to the Illustrated Parts List in this manual.
2. The Hydraulic Beadbreaker is shipped fully assembled and ready to use. Remove all packaging material and discard.
3. Check reservoir fluid level; allow no more than one-eighth inch (1/8") down. **The type of hydraulic fluid is MIL-PRF-5606.**

## 4.0 TRAINING

### 4.1 TRAINING REQUIREMENTS

The employer of the operator is responsible for providing a training program sufficient for the safe operation of the unit.

### 4.2 TRAINING PROGRAM

The employer provided operator training program should cover safety procedures concerning use of the unit in and around the intended aircraft at the intended aircraft servicing location.

### 4.3 OPERATOR TRAINING

The operator training should provide the required training for safe operation of the unit.

**NOTE: Maintenance and Trouble Shooting are to be performed by a skilled and trained technician.**

**5.0 OPERATION****WARNING!**

- **ALWAYS** follow the wheel manufacturer's instructions and procedures relative to their respective products.
- **DO NOT** attempt to disassemble wheel until tire has been completely deflated; otherwise, serious injury to personnel or damage to equipment can result.
- **DO NOT** attempt to remove valve core until tire has been completely deflated. Valve cores will be ejected at high velocity if unscrewed before air pressure has been released.

**5.1 BOLTED/SPLIT WHEEL ASSEMBLIES**

1. To break the tire bead on this type of wheel assembly:
2. Deflate the tire and remove the valve core.
3. Select the proper tire ring.
4. Adjust the mechanical leg extensions so that the tire/wheel assembly is within approximately two inches (2") of the tire ring or at its maximum height.

**CAUTION!**

- **Do not go beyond the last hole in the extension tube.**
- **Extend mechanical leg extensions equally; wheel support must be level.**

5. Place tire/wheel assembly onto the wheel support and center.

**NOTE:** Depending on the wheel configuration, the movable support pads may be or may not be required. If not required, slide the three support pads to the middle of the wheel support so they are out of the way.

**CAUTION!**

**The wheel rim must rest solidly on either the wheel support proper or on the support pads.**

6. Using the beadbreaker hydraulics, lift the tire/wheel assembly. As the tire nears contact with the tire ring, center the tire ring around the wheel.

**CAUTION!**

**The tire ring and wheel must have at least one-fourth inch ( 1/4") clearance and must have come in contact with the wheel proper.**

7. Continue lifting tire/wheel assembly until the tire bead breaks loose from the wheel assembly.
8. Lower and remove the tire/wheel assembly. Flip tire/wheel assembly and repeat Steps 4.1.4 through 4.1.6.

**5.2 GOODYEAR WHEEL WITH DEMOUNTABLE FLANGE (Disassembly)**

To break the tire bead on this type of wheel assembly:

1. Deflate the tire and remove the valve core.
2. Select the proper tire ring.
3. Adjust the mechanical leg extensions so that the tire/wheel assembly is within approximately two (2) inches of the tire ring or at its maximum height.

**CAUTION!**

- **Do not go beyond the last hole in the extension tube.**
- **Extend mechanical leg extensions equally; wheel support must be level.**

4. Place tire/wheel assembly onto the wheel support and center.
5. Slide the support pads under the wheel rim.

**CAUTION!**

**The wheel rim must rest solidly on the support pads.**

6. Using the beadbreaker hydraulics, lift the tire/wheel assembly. As the tire nears contact with the tire ring, center the tire ring around the wheel.

**CAUTION!**

**The tire ring and wheel must have at least one-fourth inch (1/4") clearance and must never come in contact with the wheel proper.**

7. Continue lifting tire/wheel assembly until the tire bead has broken loose from the wheel demountable flange and the demountable flange has shifted downward exposing the wheel split ring and clip.
8. Remove the wheel split ring.
9. Lower the tire/wheel assembly by releasing the beadbreaker hydraulics.

**5.2 GOODYEAR WHEEL WITH DEMOUNTABLE FLANGE (Disassembly)(continued)**

10. Remove the wheel de-mountable flange if possible. If still tight on the wheel, carefully flip the tire/wheel assembly on the wheel support and re-center.

**NOTE: The support pads must now be relocated.**

**CAUTION!**

- The support pads must be located beneath the wheel rim.
- Ensure clearance between the rim O.D. and the de-mountable flange to pass without contacting the support pads.

11. Using the beadbreaker hydraulics, lift the tire/wheel assembly. As the tire nears contact with the tire ring, center the tire ring around the wheel.

**CAUTION!**

**The tire ring and wheel must have at least one-fourth inch (1/4") inch clearance and must never come in contact with the wheel proper.**

12. Continue lifting the tire/wheel assembly until both the tire bead has been broken loose from the wheel assembly and the de-mountable flange has been pushed off the O-ring; should be resting on the wheel support proper.
13. Lower the tire/wheel assembly and carefully remove the component parts.

**5.3 GOODYEAR WHEEL WITH DEMOUNTABLE FLANGE (Assembly)**

To install a tire on this wheel assembly:

1. Remove two (2) of the three (3) pins holding the tire ring in place and flip the ring out of the way.
2. Place the wheel on the wheel support and center.

**NOTE: The support pads are not required here and should be slid to the middle of the wheel support.**

**CAUTION**

**The wheel rim must rest solidly on the wheel support.**

3. Install tire onto wheel following manufacturer's instructions for alignment.
4. Re-install the tire ring.
5. Compress tire by lifting the wheel with the beadbreaker hydraulics. The tire ring must be centered on the tire.
6. Complete the installation of the beadbreaker ring, de-mountable flange, split ring, retaining clip and safety wire per manufacturer's instructions.
7. Lower the tire/wheel assembly and remove from the wheel support.



## 6.0 OPTIONAL TIRE RINGS

The following table is a listing of available tire rings for use on tires. To determine the ring size you require, add 0.55 inches to the wheel maximum O.D., then round this number to the next higher whole number.

SIZING (inches)	WITHOUT CHINES	WITH CHINES
6	Z-1063-06	Z-1064-06
7	Z-1063-07	Z-1064-07
8	Z-1063-08	Z-1064-08
9	Z-1063-09	Z-1064-09
10	Z-1063-10	Z-1064-10
11	Z-1063-11	Z-1064-11
12	Z-1063-12	Z-1064-12
13	Z-1063-13	Z-1064-13
14	Z-1063-14	Z-1064-14
15	Z-1063-15	Z-1064-15
16	Z-1063-16	Z-1064-16
17	Z-1063-17	Z-1064-17
18	Z-1063-18	Z-1064-18
19	Z-1063-19	Z-1064-19
20	Z-3072-20	Z-1064-20
21	Z-3072-21	--
22	Z-3072-22	-

*EXAMPLE: For a wheel O.D. of 11.62 inches, the calculation is as follows:*

- STEP 1.     11.62 inches     (Maximum wheel O.D.)  
               + 0.55            (Tronair standard size factor)  
               = 12.17
- STEP 2.     Rounding to next whole number gives 13.
- STEP 3.     A "sizing" number of 13 dictates a Z-106X-13 tire ring

## 7.0 MAINTENANCE

- Periodically perform a visual inspection of the beadbreaker assembly. Repair or replace suspect parts.
- Maintain the correct hydraulic oil level in the pump reservoir. Reference **3.0 Preparation for Use**, section **3.3**

## 8.0 PROVISION OF SPARES

### 8.1 SOURCE OF SPARE PARTS

Spare parts may be obtained from the manufacturer:

**TRONAIR**, Inc.

1 Air Cargo Pkwy East

Swanton, Ohio 43558 USA

Telephone: (419) 866-6301 or 800-426-6301

Fax: (419) 867-0634

E-mail: sales@tronair.com

Website: www.tronair.com

### 8.2 RECOMMENDED SPARE PARTS LISTS

Reference the following page(s) for Replacement Parts and Kits available.

## 9.0 IN SERVICE SUPPORT

Contact Tronair, Inc. for technical services and information. See Section 1.3 – Manufacturer.



## 10.0 GUARANTEES/LIMITATION OF LIABILITY

Tronair products are warranted to be free of manufacturing or material defects for a period of one year after shipment to the original customer. This is solely limited to the repair or replacement of defective components. This warranty does not cover the following items:

- a) Parts required for normal maintenance
- b) Parts covered by a component manufacturers warranty
- c) Replacement parts have a 90-day warranty from date of shipment

If you have a problem that may require service, contact Tronair immediately. Do not attempt to repair or disassemble a product without first contacting Tronair, any action may affect warranty coverage. When you contact Tronair be prepared to provide the following information:

- a) Product Model Number
- b) Product Serial Number
- c) Description of the problem

If warranty coverage is approved, either replacement parts will be sent or the product will have to be returned to Tronair for repairs. If the product is to be returned, a Return Material Authorization (RMA) number will be issued for reference purposes on any shipping documents. Failure to obtain a RMA in advance of returning an item will result in a service fee. A decision on the extent of warranty coverage on returned products is reserved pending inspection at Tronair. Any shipments to Tronair must be shipped freight prepaid. Freight costs on shipments to customers will be paid by Tronair on any warranty claims only. Any unauthorized modification of the Tronair products or use of the Tronair products in violation of cautions and warnings in any manual (including updates) or safety bulletins published or delivered by Tronair will immediately void any warranty, express or implied.

The obligations of Tronair expressly stated herein are in lieu of all other warranties or conditions expressed or implied. **Any unauthorized modification of the Tronair products or use of the Tronair products in violations of cautions and warnings in any manual (including updates) or safety bulletins published or delivered by Tronair will immediately void any warranty, express or implied and Tronair disclaims any and all liability for injury (WITHOUT LIMITATION and including DEATH), loss or damage arising from or relating to such misuse.**

## 11.0 APPENDICES

APPENDIX I Declaration of Conformity



This page left blank intentionally.

**Parts List Illustrations**

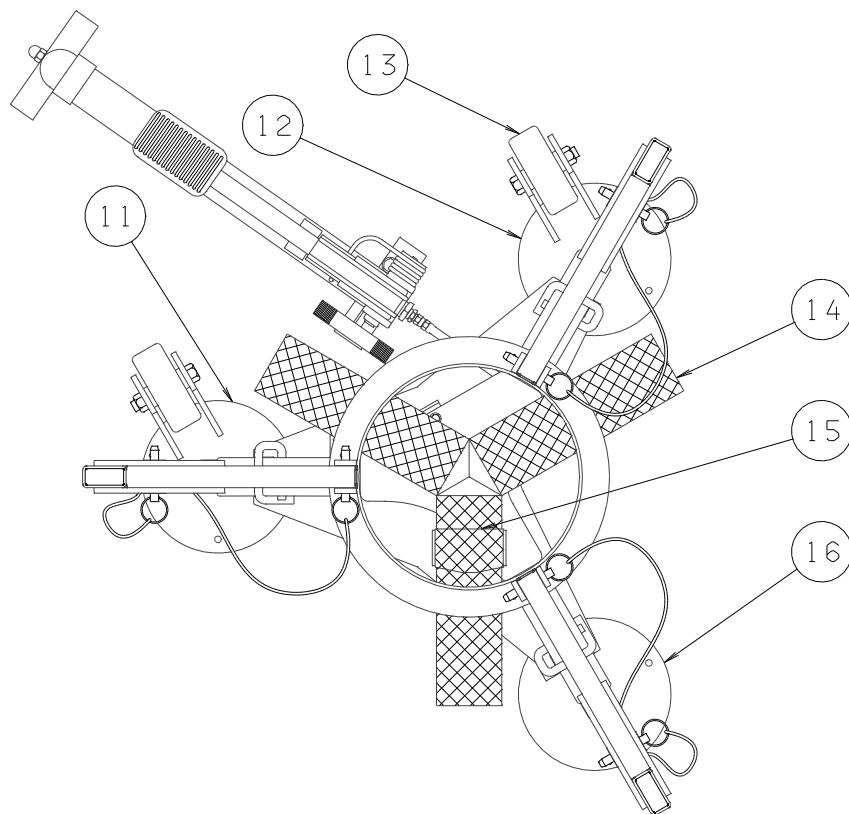
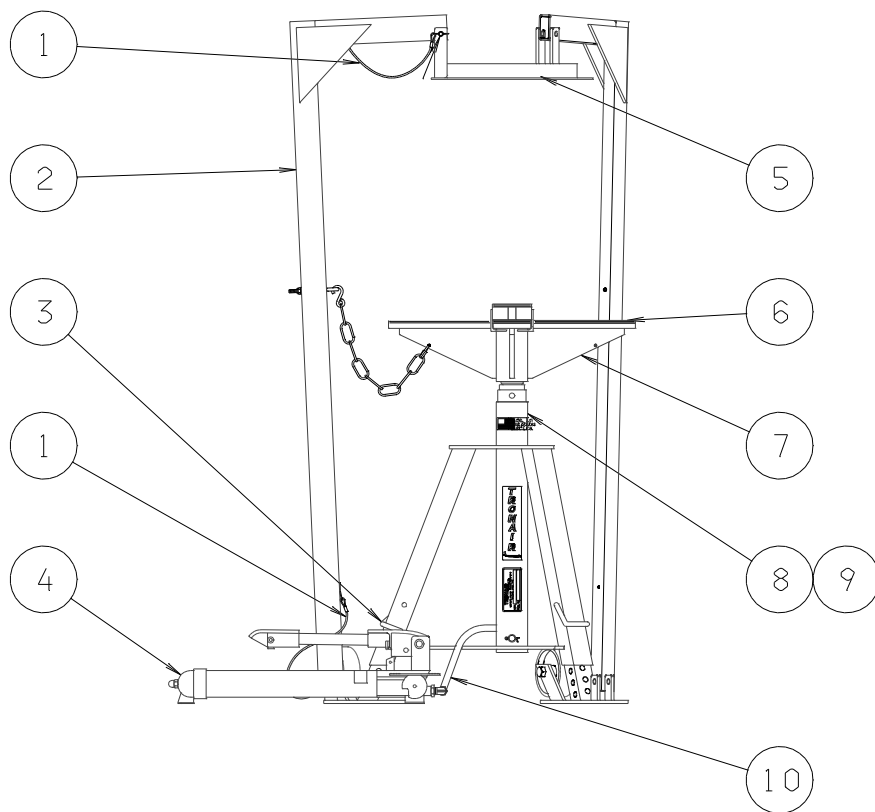



## Parts List

When ordering Replacement Parts/Kits, please specify Model, Color and Serial Number of your Unit.

Item	Part Number	Description	Qty
2	Z-1069-00	Weldment, Arm	3
3	G-1311-01	Pin, Lock	3
4	HC-2878	Pump, Foot	1
5	See 6.0 Optional Tire Rings	Weldment, Tire Ring	1
10	TF-1038-14*30.0	Assembly, Hose	1
11	Z-1136-02-00	Weldment, Leg Set	1
12	Z-1136-03-00	Weldment, Leg Set	1
14	H-1022	Pad, Neoprene	3
15	H-1023	Pad, Neoprene	3
16	Z-1136-01-00	Weldment, Leg Set	1
1	<b>K-2377</b>	<b>Kit, Replacement Pin; consists of:</b>	
	G-1307-0618	'C' Pin, 3/8" x 1.8" long	1
	G-1351-04	Rivet, 1/8" Open-End Steel	1
	H-1026*12.0	Assembly, Lanyard	1
6	<b>K-2378</b>	<b>Kit, Support Pad; consists of:</b>	
	Z-1073	Weldment, Support Pad	1
	H-1023	Padding, Neoprene	1
7	<b>K-2379</b>	<b>Kit, Wheel Support; consists of:</b>	
	Z-1066-00	Weldment, Support	1
	H-1022	Padding, Neoprene	1
8	<b>K-2572-02</b>	<b>Kit, Cylinder Replacement</b>	1
9	<b>K-4539</b>	<b>Kit, Cylinder Seal</b>	
13	<b>K-1165</b>	<b>Kit, Replacement Wheel; consists of:</b>	
	U-1002	Wheel	2
	G-1203-1095	Jamnut, 1/2-20 Elastic	2
	G-1100-109526	Bolt, 1/2-20 Hex Head, Grade '5'	2





## **APPENDIX I**

### **Declaration of Conformity**





## DECLARATION of CONFORMITY

The design, development and manufacture is in accordance with European Community guidelines

14-6801-0120

Relevant provisions complied with by the machinery:  
2006/42/EC

Identification of person empowered to sign on behalf of the Manufacturer:

A handwritten signature in black ink that reads "Patrick Finch". The signature is written in a cursive style and is positioned above a solid horizontal line.

Quality Assurance Representative