



Model: 8844B
(884400B-1, 884400B-2, 884400B-3)
Landing Gear Strut Service Unit

09/2023 – Rev. 04

For Spare Parts, Operations & Service Manuals or Service Needs
Scan the QR code or visit Tronair.com/aftermarket



REVISION	DATE	TEXT AFFECTED
01	06/2019	Original release
02	08/2020	Modified 7.2 Recommended Spare Parts List and Parts List
03	07/2023	Modified Parts List – Figure 2
04	09/2023	Modified 3.0 Preparation Prior to First use, 5.2 Operating Instructions, Control Panel



TABLE OF CONTENTS

PAGE

1.0	PRODUCT INFORMATION	1
1.1	DESCRIPTION.....	1
1.2	MODEL & SERIAL NUMBER.....	1
1.3	MANUFACTURER.....	1
1.4	SPECIFICATIONS	1
2.0	SAFETY INFORMATION.....	1
2.1	USAGE AND SAFETY INFORMATION	1
3.0	PREPARATION PRIOR TO FIRST USE	2
4.0	TRAINING.....	2
4.1	TRAINING REQUIREMENTS	2
4.2	TRAINING PROGRAM	2
4.3	OPERATOR TRAINING	2
5.0	OPERATION.....	3
5.1	PRE OPERATION INSPECTION.....	3
5.2	OPERATING INSTRUCTIONS	3
6.0	MAINTENANCE.....	4
6.1	SERVICING	4
6.2	DISASSEMBLY INSTRUCTIONS.....	4
6.3	REPAIR AND REPLACEMENT	4
7.0	PROVISION OF SPARES.....	5
7.1	SOURCE OF SPARE PARTS.....	5
7.2	RECOMMENDED SPARE PARTS LISTS	5
8.0	IN SERVICE SUPPORT.....	6
9.0	GUARANTEES/LIMITATION OF LIABILITY	6
10.0	APPENDICIES	6



This product can not be modified without the written approval of Tronair, Inc. Any modifications done without written approval voids all warranties and releases Tronair, Inc., its suppliers, distributors, employees, or financial institutions from any liability from consequences that may occur. Only Tronair OEM replacement parts shall be used.



CAUTION!

Aircraft manufacturer's specifications and instructions must be followed. In the event of contradiction between aircraft manufacturer's specifications and Malabar's, aircraft manufacturer's will prevail.

1.0 PRODUCT INFORMATION

1.1 DESCRIPTION

The Malabar Model 8844B is a nitrogen and hydraulic mobile unit designed primarily for servicing and maintaining aircraft landing gear struts. This unit will service all narrow and wide body aircraft and is equipped with four 24 inch diameter foam filled wheels, control panel assembly, dual chamber reservoir and frame assembly including an air operated hydraulic pump, two 25 foot service hoses and hose racks and the following optional equipment:

- Retractable service hose reels (2)

The unit is designed to handle 3000 psig maximum regulated nitrogen. The unit comes equipped with a 3" lunette eye for ease of towing.

1.2 MODEL & SERIAL NUMBER

Reference nameplate on unit

1.3 MANUFACTURER

Malabar International
1 Air Cargo Pkwy East
Swanton, Ohio 43558 USA

Telephone: (419) 866-6301 or 800-426-6301
E-mail: sales@malabar.com
Website: www.malabar.com

1.4 SPECIFICATIONS

Unit Weight without optional equipment (dry)	265 lbs (120 kg)
Shipping Weight without optional equipment (dry)	365 lbs (165.6 kg)
Hydraulic Fluid Weight	140 lbs (63.5 kg)
Hydraulic Fluid	MIL-PRF-5606 or equivalent
Hydraulic Bypass Relief Valve set at.....	3000 psig
Clean Reservoir Capacity.....	8.5 gal (32.2 l)
Waste Reservoir Capacity.....	7 gal (26.5 l)
Air Inlet.....	90-110 psig
Regulated Nitrogen Inlet.....	3000 psig maximum
Fluid Pump Air Consumption.....	56 scfm @ 100 psig
Fluid Pump Nitrogen Consumption	62 scfm @ 100 psig
Fluid Delivery Rate	2 gpm @ 1500 psig
Suction Fluid Filter.....	10 micron nominal
Return Fluid Filter.....	25 micron nominal
Vacuum Degassing System	20 in (50.8 cm) Hg
Maximum Towing Speed.....	20 mph (32.2 kph)
Optional: Retractable Service Hose Reels (2)	
Additional Weight	30 lbs (13.6 kg)
Hose.....	25 ft (7.6 m) high pressure hose per reel

2.0 SAFETY INFORMATION

2.1 USAGE AND SAFETY INFORMATION

To insure safe operations please read the following statements and understand their meaning. Also refer to your equipment manufacturer's manual for other important safety information. This manual contains safety precautions which are explained below. Please read carefully.



WARNING!

Warning is used to indicate the presence of a hazard that can cause **severe personal injury, death, and/or substantial property damage** if the Warning Notice is ignored.



CAUTION!

Caution is used to indicate the presence of a hazard, which will or can cause **minor personal injury or property damage** if the Caution Notice is ignored.

3.0 PREPARATION PRIOR TO FIRST USE

The unit is shipped fully assembled and ready to use. Before placing unit in operation, perform the following procedure:

1. Remove filler cap located on top of the reservoir.
2. Fill lower clean reservoir to arrow on "fill to here only" placard located next to lower liquid level gauge with MIL-PRF-5606 hydraulic fluid (approximately 8 gallons) or approved equivalent (refer to figure 1C, item 72). Replace filler cap



CAUTION!

DO NOT overfill reservoir

3. Fill pump lubricator with SAE #10 oil (refer to figure 1A, item 9).
4. Prime air operated hydraulic pump as follows:
 - a. Connect air supply to Air Inlet on side of control panel.
 - b. Set Main Valve on control panel to BYPASS / HYDRAULIC PUMP BYPASS TO RESERVOIR position.
 - c. Open hydraulic supply valve located between reservoir and suction filter.
 - d. Open ball valve in pump outlet bypass for PRIME PUMP operation.
 - e. Set Air Supply Valve on control panel to the TO RUN HYDRAULIC PUMP position. If the pump does not self-prime, perform the following procedure:
 - f. Remove the gauge on the pump suction filter.
 - g. Add hydraulic fluid into the port while running the pump.
 - h. Replace the gauge after the pump starts to prime.
 - i. Close ball valve in pump outlet bypass for NORMAL operation

4.0 TRAINING

4.1 TRAINING REQUIREMENTS

The employer of the operator is responsible for providing a training program sufficient for the safe operation of the unit.

4.2 TRAINING PROGRAM

The employer provided operator training program should cover safety procedures concerning use of the unit in and around the intended aircraft at the intended aircraft servicing location.

4.3 OPERATOR TRAINING

The operator training should provide the required training for safe operation of the unit.

NOTE: Maintenance and Trouble Shooting are to be performed by a skilled and trained technician.

5.0 OPERATION

5.1 PRE OPERATION INSPECTION

Each time the unit is to be used, inspect the following:

1. Check the frame structure for rigidity. Make sure all bolts are tightened.
2. Check system for any leaks. Fix or tighten as required.
3. Check reservoir for proper level. Ensure hydraulic fluid is not above arrow on "fill to here only" placard. Drain down if necessary.



CAUTION

DO NOT overfill reservoir (8 gallon capacity).

5.2 OPERATING INSTRUCTIONS

NOTE: The following procedures (steps 1 thru 4) should be used only as a guide. Contact your Aircraft Maintenance Department for the approved procedure. Malabar has separate service procedures for the following applications: Service Procedure (SP8844BDC-1, Appendix I) for Dual Chamber Struts and Service Procedure (SP8844BSC-2, Appendix I) for Single Chamber Struts

1. To remove hydraulic oil and nitrogen gas from landing gear strut(s):
 - a. Connect appropriate service hose(s) from service unit to the desired strut service valve(s).



CAUTION!

Air pump air relief valve must be installed at all times. If air relief valve is removed, it is possible to over pressurize the pneumatic system which could cause equipment failure and possible bodily injury.

- b. Connect air supply (90-110 psig) to the Air Inlet on side of control panel.
- c. Close Strut Control Valves.
- d. Set Main Valve to the STRUT TO WASTE TANK / STRUT SYSTEM HYDRAULIC FLUID TO RESERVOIR position.
- e. Slowly open strut service valve(s).
- f. Slowly open the Strut Control Valve that corresponds to the strut service valve that is to be deflated. Nitrogen and hydraulic fluid will be vented into the upper waste reservoir where they will be separated. Nitrogen will vent out of the reservoir via the Nitrogen exhaust silencer.
- g. Set Air Supply Valve to the TO RUN VACUUM PUMP position and pump down to 25" Hg. This will vent nitrogen out of the reservoir and evacuate residual hydraulic fluid from strut.
- h. Close Strut Control Valve.
- i. Set Main Valve to the BYPASS / HYDRAULIC PUMP BYPASS TO RESERVOIR position.
- j. Set Air Supply Valve to the OFF position.
2. To deliver high pressure hydraulic fluid to landing gear strut(s):
 - a. Close Strut Control Valves.
 - b. Set Main Valve to the FLUID TO STRUT / HYDRAULIC FLUID TO STRUT SYSTEM position.
 - c. Open the appropriate Strut Control Valve.
 - d. Set Air Supply Valve to the TO RUN HYDRAULIC PUMP position until desired amount of hydraulic oil has been delivered.
 - e. Set Air Supply Valve to OFF position.
 - f. Close Strut Control Valve.
 - g. Set Main Valve to the BYPASS / HYDRAULIC PUMP BYPASS TO RESERVOIR position.
3. To deliver high pressure nitrogen gas to landing gear strut(s):
 - a. Close Strut Control Valves.
 - b. Set Main Valve to the BYPASS / HYDRAULIC PUMP BYPASS TO RESERVOIR position.
 - c. Connect regulated nitrogen supply (3000 psig maximum) to the Nitrogen Inlet on side of control panel.



CAUTION!

Regulated nitrogen supply must not exceed 3000 psig. If regulated nitrogen supply exceeds 3000 psig, it is possible to over pressurize the pneumatic system which could cause equipment failure and possible bodily injury.

- d. Adjust nitrogen regulator to the fully counter-clockwise (off) position.
- e. Slowly open the nitrogen bottle valve.
- f. Open the appropriate Strut Control Valve.
- g. Press "PSI" (white) button to turn on digital Strut Control Pressure Gauge.
- h. Adjust nitrogen regulator clockwise to obtain appropriate nitrogen pressure.
- i. Close Strut Control Valve.
- j. Adjust nitrogen regulator to the fully counter-clockwise (off) position.
- k. Close nitrogen bottle valve.

5.2 OPERATING INSTRUCTIONS (*continued*)

- l. Set Main Valve to the STRUT TO WASTE TANK / STRUT SYSTEM HYDRAULIC FLUID TO RESERVOIR position. This will vent nitrogen pressure from the service unit.
- m. Set Main Valve to the BYPASS / HYDRAULIC PUMP BYPASS TO RESERVOIR position.
4. To vent hoses for storage:



CAUTION!

Check reservoir for proper level. Ensure hydraulic fluid is not above arrow on "fill to here only" placard. Drain down if necessary.

- a. Make sure strut service valves are closed.
- b. Set Main Valve to the STRUT TO WASTE TANK / STRUT SYSTEM HYDRAULIC FLUID TO RESERVOIR position.
- c. Open the appropriate Strut Control Valve(s). This will vent the corresponding hose(s).
- d. Disconnect the service hose(s) from the Strut. If service unit is equipped with retractable hose reels, retract service hose(s). Otherwise, re-coil service hose(s) onto hose rack(s) and fasten hose strap(s)
- e. Disconnect air supply hose to service unit. Disconnect regulated nitrogen supply hose to service unit. Set all Control Panel Valves to off or closed position.
- f. Set Main Valve to the BYPASS / HYDRAULIC PUMP BYPASS TO RESERVOIR position

6.0 MAINTENANCE

6.1 SERVICING

Servicing the unit consists primarily of the following:

1. Fill pump lubricator with SAE #10 oil.
2. Replace desiccant dryer silica gel when necessary (color changes from blue to pink).
3. Replace fluid filters every 13 - 52 weeks or sooner.
4. Tires are foam filled. Do not attempt to inflate tires

6.2 DISASSEMBLY INSTRUCTIONS

When necessary to disassemble the unit, carefully inspect the following:

1. Check for corrosion and wear.
2. Inspect condition of all hoses.
3. Check frame structure for damage.
4. Drain and clean out reservoir.

6.3 REPAIR AND REPLACEMENT

No definite time schedule can be established for the overhaul of the unit for replacement of the various moving parts. The number of times the unit is used materially affects the life of the working parts. Each time the unit is disassembled, carefully repair or replace the following:

1. Replace all defective parts and missing parts.
2. Clean metal parts with cleaning solvent and dry with compressed air.
3. Lubricate all threads and bearings.

7.0 PROVISION OF SPARES
7.1 SOURCE OF SPARE PARTS

Spare parts may be obtained from the manufacturer:

Malabar International

1 Air Cargo Pkwy East
 Swanton, Ohio 43558 USA

Telephone: (419) 866-6301 or 800-426-6301

E-mail: sales@malabar.com

Website: www.malabar.com

For Spare Parts, Operations & Service Manuals or Service Needs:
 Scan the QR code or visit Tronair.com/aftermarket

7.2 RECOMMENDED SPARE PARTS LISTS

Reference the following page(s) for Replacement Parts and Kits available.

The following spare parts are recommended and available upon request.

Part Number	Description	Qty
492-214	Foam filled mag style wheel	4
441-156	Seal kit, air pump	1
481-072	Suction filter assembly	1
481-143	Suction filter element	1
481-089	Return filter assembly	1
481-090	Return filter element	1
481-074	Desiccant dryer	1
WF174195	Desiccant dryer silica gel	4 oz
471-001	Lubricator	1
481-076	Silencer/mist eliminator	1
484-025	Liquid level gauge	2
482-072	Vacuum gauge	1
482-084	Pressure gauge	1
423-039	Bypass relief valve	1
490-021	Vacuum pump	1
424-053	Directional control valve	1
424-037	Manual 4-way valve	1
85416	Release valve	2
425-001	Air relief valve	1
423-040	Pressure relief valve	1
422-058	Check valve	2
422-056	Check valve	1
421-045	Check valve	1
422-059	Ball valve	1
424-005	Drain cock valve	2
424-033	Ball Valve	1
483-005	Breather	1
884440	Control panel placard	1
9-7035	Nameplate	1
75939	Sticker, towing	1
55998	Sticker, Malabar	1
884455	Placard, bleed	1
PF55561	Placard, fill	1
719-009	Safety chuck	2
837721-19	Service hose	2
* 499-039	Swivel joint	2
* 837721-24	Service hose	2
* 877685-11	Hose	2
424-033	Ball Valve	1

* Optional equipment - These parts required only when supplied with unit.



8.0 IN SERVICE SUPPORT

Contact Malabar, Inc. for technical services and information. See Section 1.3 – Manufacturer.

9.0 GUARANTEES/LIMITATION OF LIABILITY

- I. Seller warrants each new product of its manufacture to be free from defects in material or workmanship, under proper, reasonable, and normal use and service.
- II. The warranty period shall be as follows:
 - A. For Malabar equipment, with the exception of Tripod Jacks, the warranty period is one (1) year after date of shipment.
 - B. For Malabar Tripod Jacks, the warranty period is three (3) years after date of shipment.
- III. Where Buyer claims an alleged defect in material or workmanship and so advises Seller in writing within ten (10) days after discovery thereof, then and in such event, Buyer shall return said equipment, transportation prepaid, to the Seller, provided such return is timely and within the above-mentioned warranty period. This warranty and liability of the Seller is expressly limited solely to replacement or repair of defective parts or goods, and return at Buyer's expense to Buyer after finding by Seller the product was defective prior to original shipment or, at the option of Seller, to providing refund to Buyer of the purchase price for said product.
- IV. It is further expressly understood and agreed that:
 - A. THERE IS NO WARRANTY, REPRESENTATION OF CONDITION OF ANY KIND, EXPRESS OR IMPLIED, (INCLUDING NO WARRANTY OF MERCHANTABILITY OR OF FITNESS) EXCEPT THAT THE MATERIAL SHALL BE OF THE QUALITY SPECIFIED IN APPLICABLE SPECIFICATIONS, AND NONE SHALL BE IMPLIED BY LAW. Except as otherwise provided herein, quality shall be in accordance with Seller's specifications. Final determination of the material for the use contemplated by Buyer is the sole responsibility of Buyer and Seller shall have no responsibility in connection with such suitability, and
 - B. Buyer's sole and exclusive remedy shall be repair or replacement of defective parts or goods by the Seller. Should the goods, in the judgment of Seller, preclude the remedying of the warranted defects by repair or replacement, the Buyer's sole and exclusive remedy shall be the refund of the purchase price, and
 - C. Seller shall not be liable for prospective profits or special, indirect or consequential damages, nor shall any recovery of any kind against Seller be greater in amount than the purchase price of the specific material sold and causing the alleged loss, damage or injury. Buyer assumes all risk and liability for loss, damage or injury to persons or property of Buyer or others arising out of use or possession of any product or part sold hereunder, and
 - D. Seller shall in no way be deemed or held to be obligated, liable or accountable upon or for any guarantees or warranties, express or implied, or created by statute or by operation of law or otherwise, in any manner of form beyond its express agreement above set forth, and
 - E. No warranty herein shall apply to any product which shall have been repaired or altered, unless such alteration or repair has been made by Seller or if, after return to and inspection by Seller, the product is found by Seller to have been subject to misuse, negligence or accident, and
 - F. No warranty of any nature is made by Seller as to any component forming a part of the product sold and Buyer shall receive only such warranties offered by such other manufacturer of such component, and
 - G. Seller does not assume nor does Seller authorize any other person to assume for it any other liability or make any warranty in connection with the sale of its products.

10.0 APPENDICIES

- Appendix I Service Procedure SP8844BDC-1
- Appendix II Service Procedure SP8844BSC-2

Control Panel

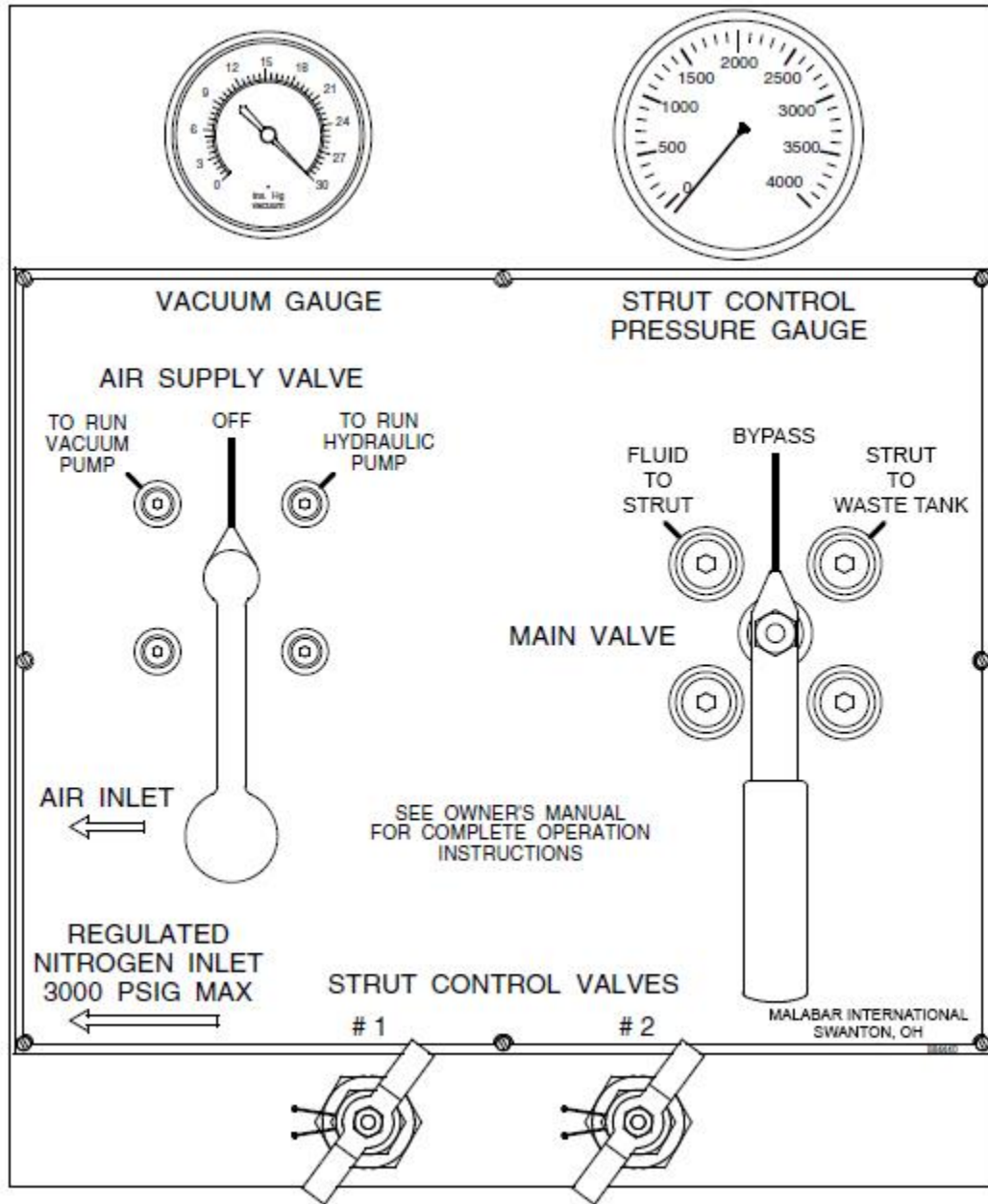

Pneumatic Diagram

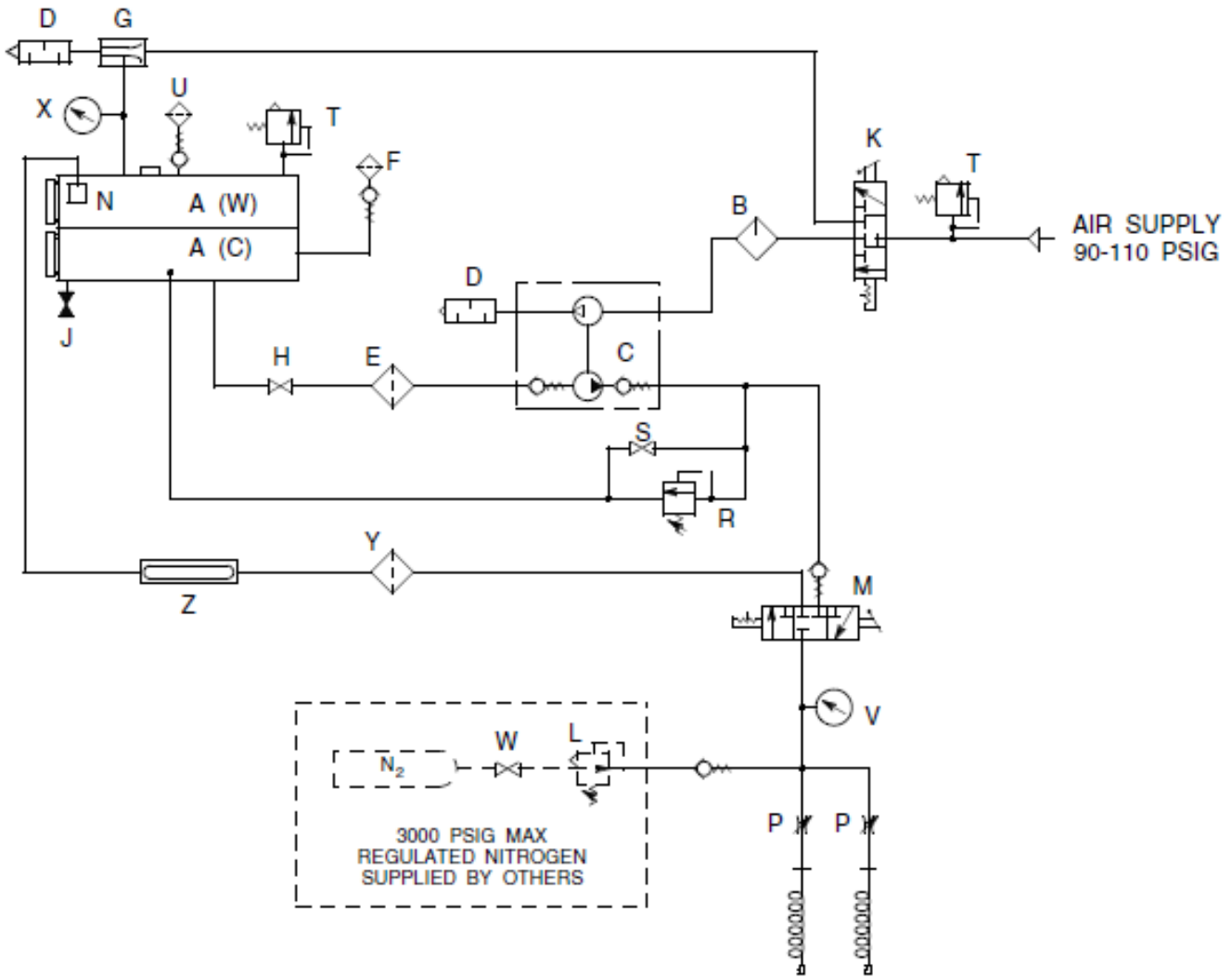

- | | |
|------------------------------------|---|
| A (W) - 7 GALLON WASTE RESERVOIR | M - MAIN VALVE |
| A (C) - 8.5 GALLON CLEAN RESERVOIR | N - NITROGEN DIFFUSER |
| B - AIR LUBRICATOR | P - STRUT CONTROL VALVE |
| C - AIR OPERATED PUMP | R - HYDRAULIC PRESSURE RELIEF VALVE |
| D - MUFFLER | S - BALL VALVE |
| E - PUMP SUCTION FILTER | T - PRESSURE RELIEF VALVE |
| F - DESSICANT AIR FILTER | U - EXHAUST SILENCER/FILTER |
| G - VACUUM PUMP | V - ANALOG STRUT CONTROL PRESSURE GAUGE |
| H - FILTER SERVICE SHUTOFF VALVE | W - NITROGEN SHUTOFF VALVE |
| J - DRAIN COCK VALVE | X - ANALOG VACUUM GAUGE |
| K - AIR SUPPLY VALVE | Y - RETURN FILTER |
| L - NITROGEN REGULATOR | Z - RETURN FLUID SIGHT (OPTIONAL) |

Parts List – Figure 1A

When ordering replacement parts/kits, please specify model, serial number and color of your unit.

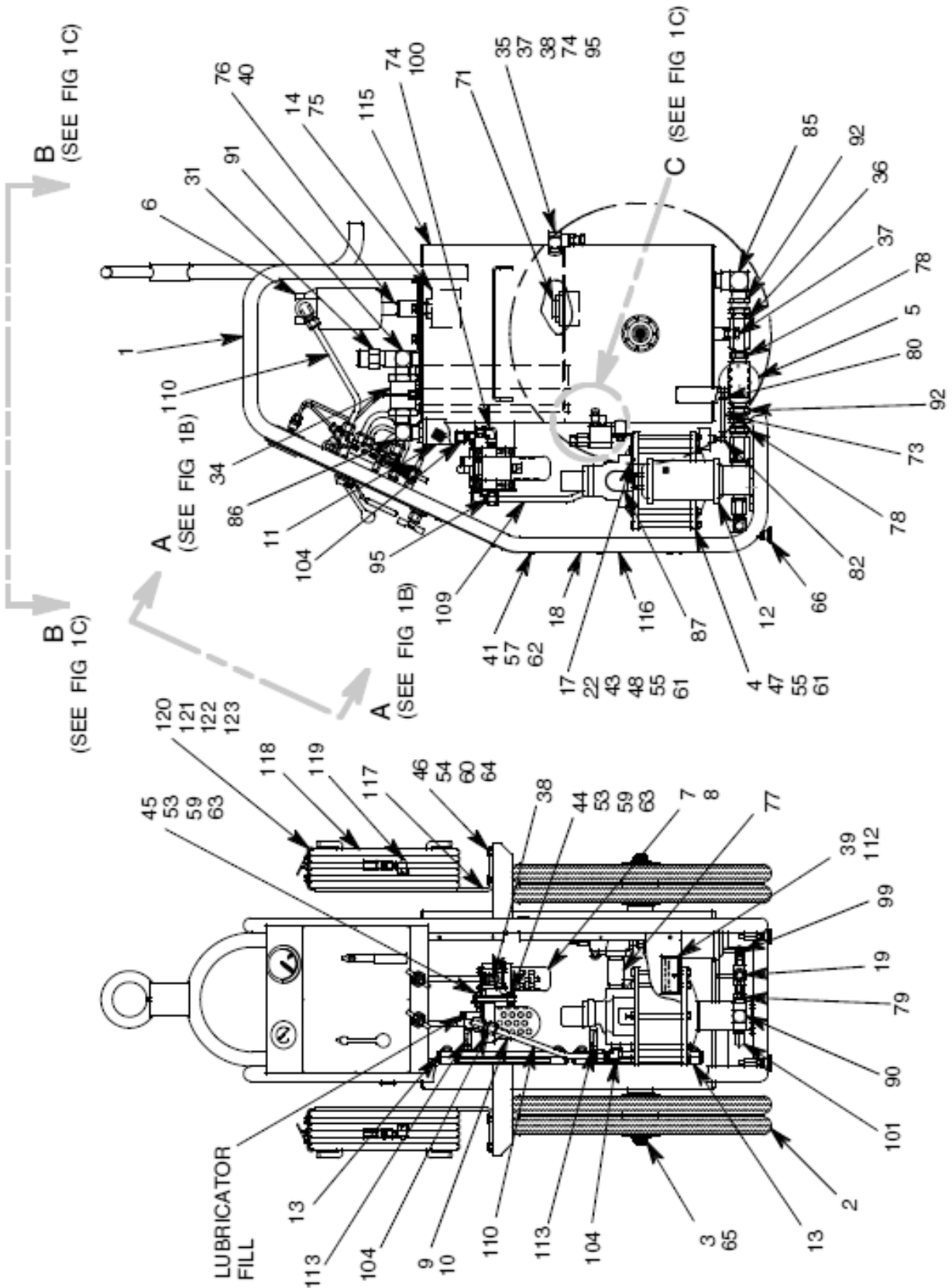

Parts List – Figure 1B

When ordering replacement parts/kits, please specify model, serial number and color of your unit.

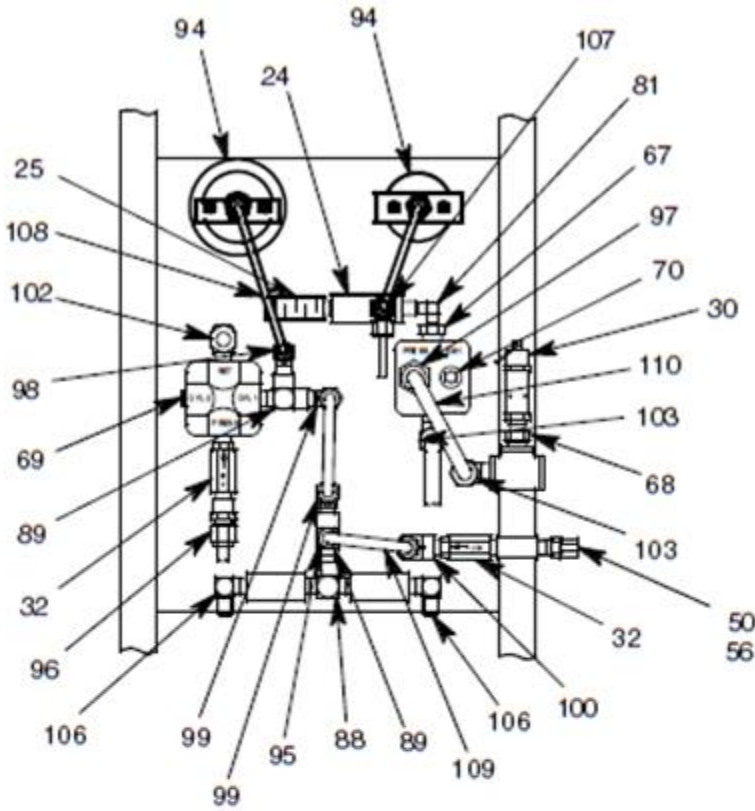

REAR VIEW

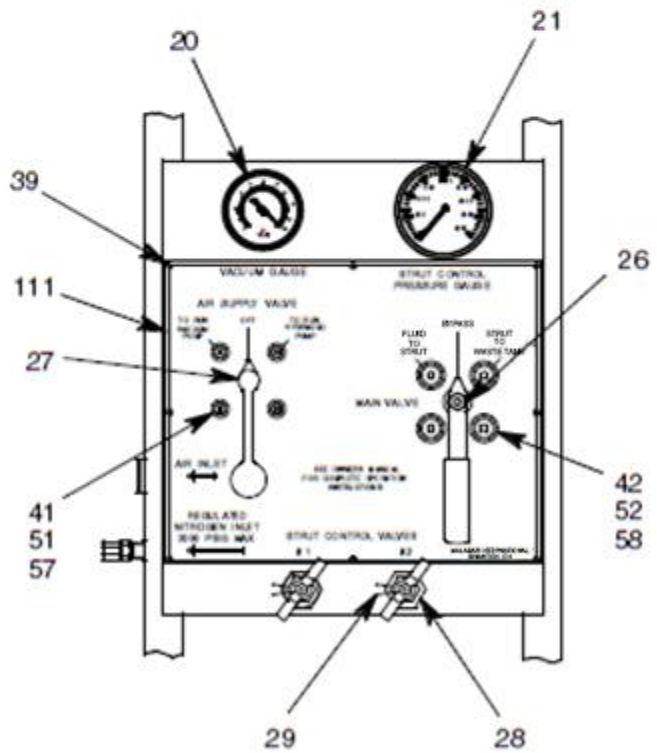

VIEW A-A
FRONT VIEW

Parts List – Figure 1A – 1C

When ordering replacement parts/kits, please specify model, serial number and color of your unit.

Item	Part Number	Description	Qty
1	884410A	RESERVOIR	1
2	492-214	WHEEL	4
3	492-116	THRUST WASHER	4
4	441-131	AIR PUMP	1
5	481-072	SUCTION SPIN-ON FILTER	1
6	481-089	RETURN SPIN-ON FILTER	1
7	481-074	DESSICANT DRYER, 1/4 FPT	1
8	481-087	DESSICANT MOUNTING BRKT	2
9	471-001	LUBRICATOR, 1/2 FPT	1
10	471-015	LUBRICATOR MTG BRKT	1
11	481-076	SILENCER / MIST ELIMINATOR	1
12	499-001	MUFFLER, 1" MPT	1
13	484-025	LIQUID LVL GAUGE, 1/4 MPT	2
14	499-029	RTN LINE DIFFUSER, 3/4 FPT	1
15	884456	RESERVOIR COVER	1
16	76347	RESERVOIR GASKET	1
17	884424A	PUMP MOUNT BRACKET	1
18	884435A	PANEL	1
19	424-033	BALL VALVE, 1/4 FPT	1
20	482-072	VACUUM GAUGE, 30 HG	1
21	482-084	PR GAUGE, 0-4000 PSIG	1
22	369-005	SPACER	1
23	423-039	BYPASS RELIEF VALVE	1
24	490-021	AIR OPERATED VAC PUMP	1
25	472-003	MUFFLER, 1/4 FPT	1
26	424-053	DIR CONTROL VALVE, 1/4	1
27	424-037	MANUAL 4-WAY VALVE	1
28	85416	RELEASE VALVE, 1/4 FPT	2
29	491-044	SAFETY LOCK WIRE, .025 DIA	AR
30	425-001	AIR RELIEF VALVE, 150 PSIG	1
31	423-052	PRESSURE RELIEF VALVE	1
32	422-058	CHECK VALVE, 1/4 MPT	2
33	422-056	CHECK VALVE, 1/4 FPT	1
34	421-045	CHECK VALVE, 1" FPT	1
35	712-003	ELBOW, STREET, 1/2 NPT	1
36	422-059	BALL VALVE, 1" FPT	1
37	424-005	DRAIN COCK, 1/2 MPT	2
38	483-005	BREATHER, 1/4 MPT	1
39	397-016	SELF TAPPING SCREW, #4	10
40	884475	FLUID SIGHT KIT	1
41	324-020	SBHCS, SS, 10-24 x 5/8 LG	14
42	324-021	SBHCS, SS, 3/8-16 x 1" LG	4

Parts List – Figure 1A – 1C

When ordering replacement parts/kits, please specify model, serial number and color of your unit.

Item	Part Number	Description	Qty
43	321-099	HHCS, 3/8-16 x 5 1/2 LG	1
44	321-096	HHCS, 1/4-20 x 1" LG	2
45	321-129	HHCS, 1/4-20 x 1 1/4 LG	2
46	321-083	HHCS, 5/16-18 x 1" LG	8
47	321-206	HHCS, 3/8-24 x 3/4 LG	2
48	321-011	HHCS, 3/8-16 x 1" LG	1
49	321-008	HHCS, 3/8-16 x 1 1/4 LG	6
50	721-138	CONN., SST, 1/4 37° x 1/4 MPT	1
51	362-045	FLAT WASHER, SS, #10	4
52	362-049	FLAT WASHER, SS, 3/8	4
53	362-001	FLAT WASHER, SAE, 1/4	8
54	362-002	FLAT WASHER, SAE, 5/16	8
55	362-003	FLAT WASHER, SAE, 3/8	9
56	717-030	CAP, 1/4 37°	1
57	364-005	SPLIT LOCKWASHER, #10	14
58	364-009	SPLIT LOCKWASHER, 3/8	4
59	363-001	SPLIT LOCKWASHER, 1/4	4
60	363-002	SPLIT LOCKWASHER, 5/16	8
61	363-003	SPLIT LOCKWASHER, 3/8	9
62	355-023	HEX LOCKNUT, 10-24	10
63	351-001	HEX NUT, 1/4-20	4
64	351-012	HEX NUT, 5/16-18	8
65	355-031	HEX LOCKNUT, 3/4-10	2
66	390-049	LEVELING FOOT	2
67	714-032	BUSHING, 3/8 MPT x 1/8 FPT	1
68	714-009	BUSHING, 3/8 MPT x 1/4 FPT	1
69	717-006	PLUG, 1/4 MPT	2
70	717-007	PLUG, 3/8 MPT	1
71	717-037	PLUG, 2" MPT	1
72	717-068	HEX PLUG, 1-1/4 SAE O-RING	1
73	711-107	NIPPLE, 1/8 MPT x 3 1/2 LG	1
74	711-003	HEX NIPPLE, 1/4 MPT	1
75	711-086	NIPPLE, CLOSE, 3/4 MPT	1
76	711-108	NIPPLE, BRASS, 3/4 MPT	1
77	711-016	NIPPLE, 1" MPT x 4" LG	1
78	711-087	HEX NIPPLE, 1" MPT	2
79	711-079	HEX NIPPLE, 1/2 x 1/4 MPT	1
80	712-060	ELBOW, STREET, 1/8 NPT	1
81	712-089	ELBOW, 1/8 MPT	1
82	712-052	ELBOW, 1/8 FPT	1
83	712-022	ELBOW, 1/4 MPT	1
84	712-027	ELBOW, STREET, 3/4 NPT	1

Parts List – Figure 1A – 1C

When ordering replacement parts/kits, please specify model, serial number and color of your unit.

Item	Part Number	Description	Qty
85	712-081	ELBOW, STREET, 1" NPT	1
86	712-080	ELBOW, 1" MPT	1
87	712-015	ELBOW, 1" FPT	1
88	713-043	TEE, BRANCH, 1/4 NPT	2
89	713-048	TEE, STREET, 1/4 NPT	3
90	713-021	TEE, BRANCH, 1/2 NPT	1
91	713-049	TEE, STREET, 1" NPT	1
92	719-003	SWIVEL ADAPTER, 1" NPT	2
93	721-012	CONNECTOR, 1/4 T x 1/4 MPT	1
94	721-070	CONNECTOR, 1/4 T x 1/4 FPT	2
95	721-009	CONNECTOR, 3/8 T x 1/4 MPT	3
96	721-008	CONNECTOR, 3/8 T x 1/4 FPT	1
97	721-025	CONNECTOR, 1/2 T x 3/8 MPT	1
98	722-021	ELBOW, 1/4 T x 1/4 MPT	1
99	722-014	ELBOW, 3/8 T x 1/4 MPT	5
100	722-016	ELBOW, 3/8 T x 1/4 FPT	2
101	722-015	ELBOW, 3/8 T x 1/2 MPT	1
102	722-041	ELBOW, 1/2 T x 1/4 MPT	1
103	722-012	ELBOW, 1/2 T x 3/8 MPT	2
104	722-013	ELBOW, 1/2 T x 1/2 MPT	3
105	722-074	ELBOW, 1/2 T x 3/4 MPT	1
106	722-005	ELBOW, 3/8 37° x 1/4 MPT	2
107	713-017	TEE, RUN, 1/4 T x 1/8 MPT	1
108	732-003	TUBE, 1/4 O.D. x .035 WALL	AR
109	732-010	TUBE, 3/8 O.D. x .065 WALL	AR
110	732-001	TUBE, 1/2 O.D. x .049 WALL	AR
111	884440	CONTROL PANEL PLACARD	11
112	884455	BLEED PLACARD	1
113	PF55561	FILL PLACARD	2
114	9-7035	NAMEPLATE	1
115	75939	STICKER, TOWING	1
116	55998	STICKER, MALABAR	1
117	884445	HOSE STAND	2
118	837721-19	DELIVERY HOSE, 27' LG	2
119	719-009	SAFETY CHUCK	2
120	837724	HOSE STRAP	2
121	321-036	HHCS, 1/4-20 x 3/4 LG	2
122	363-001	SPLIT LOCKWASHER, 1/4	2
123	351-001	HEX NUT, 1/4-20	2
124	884442A	HOSE REEL ASSEMBLY	2
125	877685-11	HOSE	2

Parts List – Figure 2

When ordering replacement parts/kits, please specify model, serial number and color of your unit.

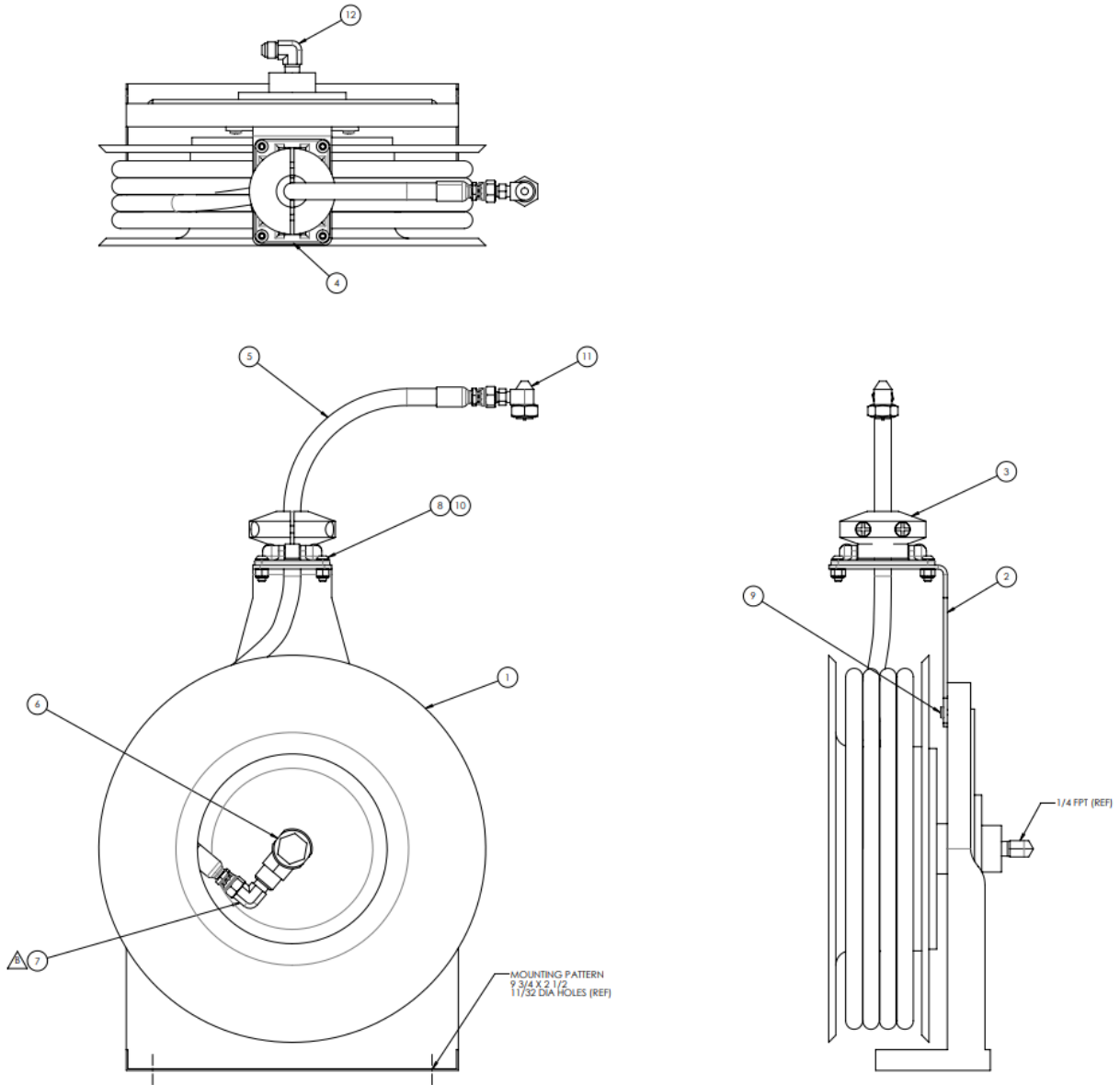

Parts List – Figure 2

When ordering replacement parts/kits, please specify model, serial number and color of your unit.

Item	Part Number	Description	Qty
	884442A	Hose Reel Assembly; consist of:	
1	499-056	HOSE REEL	1
2	884443A	HOSE REEL BRACKET	1
3	499-038	HOSE BUMPER	1
4	499-055	ROLLER HOSE GUIDE	1
5	837721-24	HOSE ASSEMBLY, 1/4 I.D.	1
6	499-039	SWIVEL JOINT, 4000 PSI	1
7	N-2005-04-S	ELBOW, MALE	1
8	326-011	BHSCS, 1/4-20 x 3/4 LG	4
9	341-009	RHMS, 10-32 x 1/2 LG	2
10	353-001	HEX LOCKNUT, 1/4-20	4
11	719-009	SAFETY CHUCK	1
12	722-005	ELBOW, 3/8 37° x 1/4 MPT	1

Parts List – Figure 3

When ordering replacement parts/kits, please specify model, serial number and color of your unit.

FROM FILTER OUTLET ELBOW

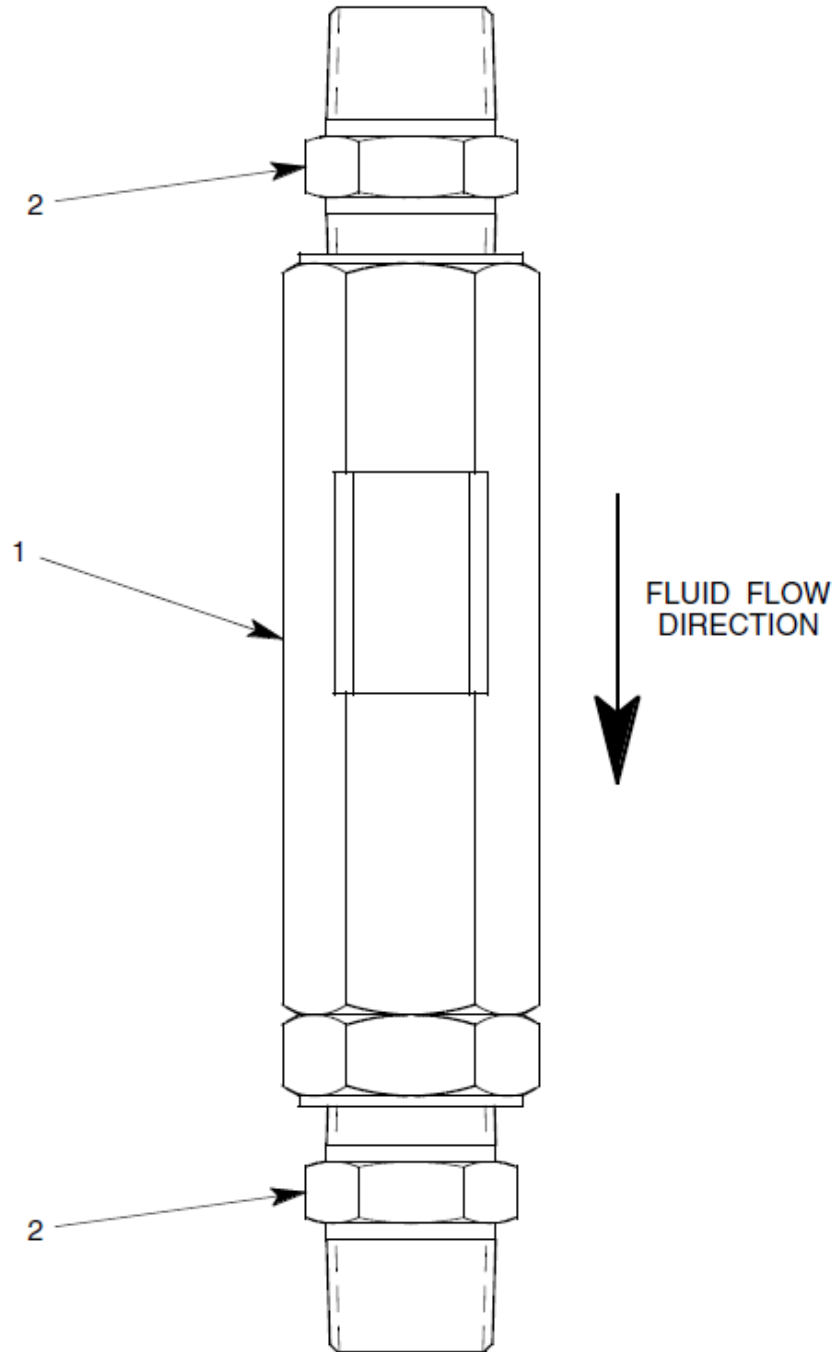

TO RESERVOIR

Item	Part Number	Description	Qty
	884475	Fluid Sight Assembly; consist of:	
1	484-027	FLUID SIGHT	1
2	711-036	NIPPLE, 3/4 MPT	2



APPENDIX I

Service Procedure SP8844BDC-1

SERVICE PROCEDURE SP8844BDC-1 DUAL CHAMBER STRUTS

Reference: 8844B Landing Gear Strut Service Unit



CAUTION!

Aircraft manufacturer's specifications and instructions must be followed. In the event of contradiction between aircraft manufacturer's specifications and Malabar's, aircraft manufacturer's specifications will prevail.

OBJECTIVE:

To properly service the Landing Gear Strut Chambers with hydraulic fluid MIL-PRF-5606 (or approved equivalent) and nitrogen.

GENERAL SERVICE DATA:

The Malabar Model 8844B utilizes the weight of the aircraft during the Strut Service Procedure. All aircraft jacks, stands, docks or other ground equipment must be clear of the aircraft. The procedures include deflating and inflating the aircraft struts which will lower and raise the aircraft structure.

DOCUMENT APPROVAL:

This document must be approved prior to its use for aircraft servicing. The following space is provided to record authorization.

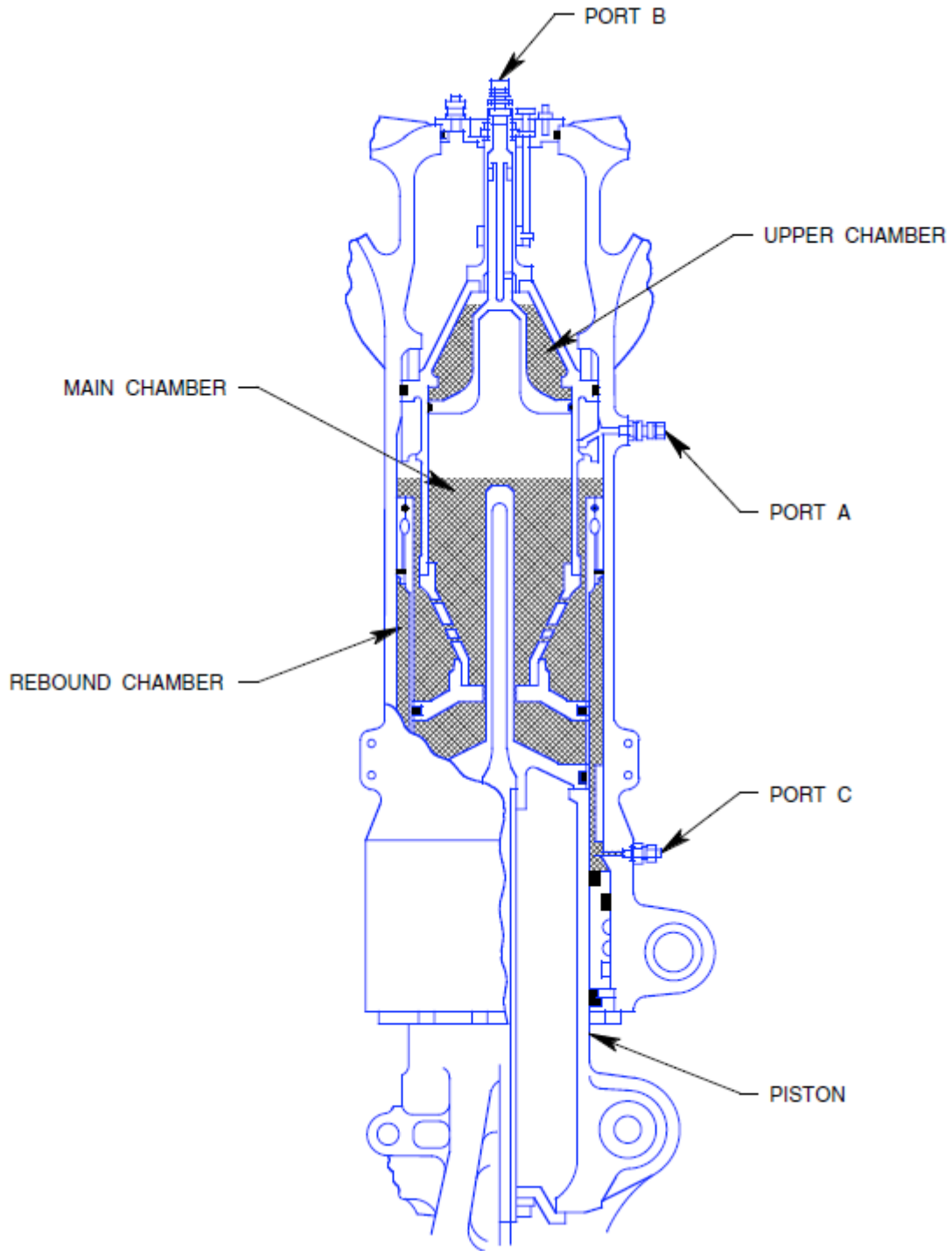

Figure 1 – Dual Chamber Main Landing Gear Shock Strut

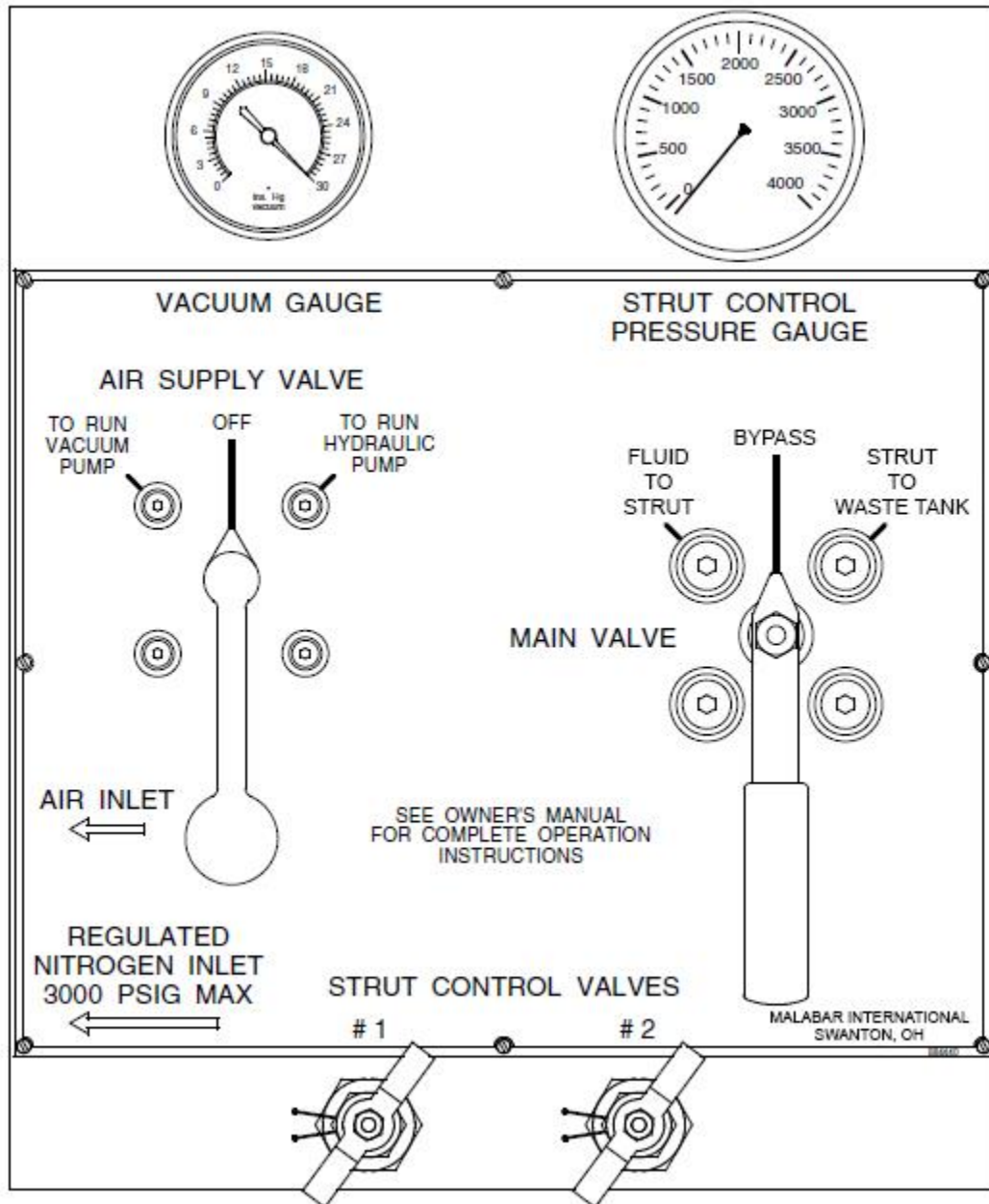

Figure 2 – Control Panel Illustration

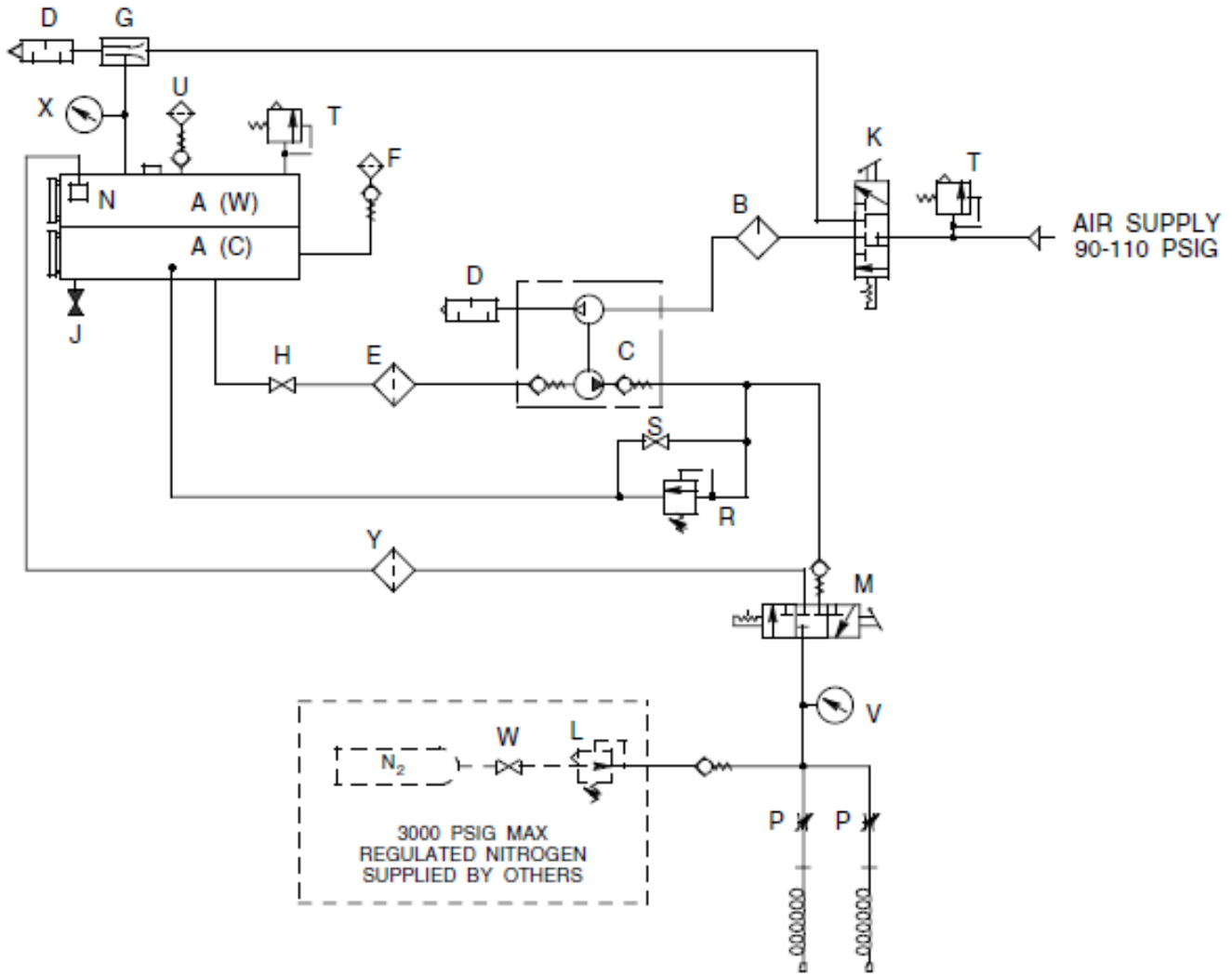

Figure 3 – Pneumatic/Hydraulic Diagram

- A(W) 7 GALLON WASTE RESERVOIR
- A(C) 8.5 GALLON CLEAN RESERVOIR
- B AIR LUBRICATOR
- C AIR OPERATED PUMP
- D MUFFLER
- E PUMP SUCTION FILTER
- F DESSICANT AIR FILTER
- G VACUUM PUMP
- H FILTER SERVICE SHUTOFF VALVE
- J DRAIN COCK VALVE
- K AIR SUPPLY VALVE
- L NITROGEN REGULATOR
- M MAIN VALVE
- N NITROGEN DIFFUSER
- P STRUT CONTROL VALVE
- R HYDRAULIC PRESSURE RELIEF VALVE
- S BALL VALVE
- T PRESSURE RELIEF VALVE
- U EXHAUST SILENCER/FILTER
- V ANALOG STRUT CONTROL PRESSURE GAUGE
- W NITROGEN SHUTOFF VALVE
- X ANALOG VACUUM GAUGE
- Y RETURN FILTER



PRIMARY SERVICE PROCEDURES:

1. Deflate the Upper Chamber, Port B.
2. Fill the Upper Chamber with hydraulic fluid, Port B.
3. Deflate the Main Chamber, Port A.
4. Fill the Main Chamber with hydraulic fluid, Port A.
5. Inflate the Upper Chamber with nitrogen, Port B.
6. Inflate the Main Chamber with nitrogen, Port A.
7. Verification of Strut Pressure, Port A and B.

AIRCRAFT POSITIONING and STRUT INSPECTION:

1. Position the aircraft to ensure the gear struts are in the normal position supporting the weight of the aircraft.
2. Check surrounding area for jacks, docks or other ground equipment and insure equipment is clear of the aircraft structure.
3. Inspect the gear strut service valves and fittings for proper installation and cleanliness.

MALABAR SERVICE UNIT POSITIONING and SERVICE CONNECTIONS:

1. Position the Service Unit clear of the aircraft gear structure with the Service Unit control panel in a position to allow the Service Technician to view both the control panel and the aircraft gear strut.
2. Verify the Service Unit hydraulic fluid lower clean reservoir sight gauge indicates at least 75% full. It is the responsibility of the user to ensure the hydraulic fluid is of the correct type to service the aircraft. A fluid tag is recommended each time the service unit reservoir is filled.
3. Verify all Control Panel valves are in the OFF or closed position.
4. Verify Main Valve is in the BYPASS / HYDRAULIC PUMP BYPASS TO RESERVOIR position.
5. Connect air supply (90-110 psig) to the Air Inlet on the side of the control panel. (If this is the first time the Service Unit is used, the Service Technician will need to install a compatible air service coupling to match the air supply hose fitting).

CAUTION!

Use only nitrogen bottle(s) with shutoff valve(s) and regulator(s) serviced to a pressure not to exceed 3600 psig.

6. Connect nitrogen supply with shutoff valve(s) closed and regulator(s) off to Regulated Nitrogen Inlet (3000 psig maximum) on the side of the control panel. The minimum recommended initial nitrogen bottle pressure should be at least 3000 PSIG. (If this is the first time the Service Unit is used, the Service Technician will need to install a compatible nitrogen service coupling to match the nitrogen supply hose fitting).

CAUTION!

(Refer to Figure 1) Ensure that port a and port b service valves are lockwired in place before proceeding. Serious injury may result if the strut service valves are loosened with the strut under pressure.

7. Connecting Service Unit hoses to the Struts:
 - a. Remove Dust Caps from the Strut Air Service Valves located at Ports A and B.

NOTE: 75-100 inch-pounds is recommended when installing the Service Hose Chucks to the Strut Air Service Valves at Ports A and B; do not exceed 100 inch pounds.

- b. If Service Unit is not equipped with retractable hose reels, unwind hoses from hose racks and connect Service Hose #1 to the Air Service Valve at Port a on the side of the Strut. Connect Service Hose #2 to the Strut Service Valve at Port B on the top of the Strut.
 - c. If Service Unit is equipped with retractable hose reels; pull out hoses and connect Hose #1 to the Strut Service Valve at Port A on the side of the Strut. Connect Hose #2 to the Strut Service Valve at Port B on the top of the Strut.
8. Slowly open the Strut Service Valve at Port A (utilizing an open end wrench) by rotating the swivel nut counter-clockwise. Make sure that the lockwired Valve Body remains tight by holding in place with a wrench. This will ensure that no serious injury will occur. This procedure will pressurize the #1 Service Hose.
9. Loosen the Strut Indicator Rod (located on the top of the strut) from its stowed position and lift it until it is magnetically engaged to the strut piston magnet.
10. Slowly open the Strut Service Valve at Port B in the same manner. This procedure will pressurize the #2 Service Hose.

The Aircraft Struts and the Service Unit are now ready for the following service procedures.



PROCEDURE 1 (Deflate the Upper Chamber, Port B, Service Hose #2):

- A. Verify Strut Control Valves #1 and #2 are closed.
- B. Set Main Valve to the STRUT TO WASTE TANK / STRUT SYSTEM HYDRAULIC FLUID TO RESERVOIR position.
- C. Slowly open Strut Control Valve #2. Nitrogen and hydraulic fluid will be vented into the Waste Reservoir where they will be separated. Nitrogen will vent out of the reservoir via the exhaust muffler. Fully deflate the Upper Chamber.
- D. Set Air Supply Valve to the TO RUN VACUUM PUMP position. This will vent nitrogen out of reservoir and evacuate residual hydraulic fluid from strut.
- E. Close Strut Control Valve #2.
- F. Set Main Valve to the BYPASS / HYDRAULIC PUMP BYPASS TO RESERVOIR position.
- G. Set Air Supply Valve to the OFF position.

PROCEDURE 2 (Fill Upper Chamber with Hydraulic Fluid, Port B, Service Hose #2):

- A. Verify Strut Control Valves #1 and #2 are closed.
- B. Set Main Valve to the FLUID TO STRUT / HYDRAULIC FLUID TO STRUT SYSTEM position.
- C. Open Strut Control Valve #2 approximately 2-3 turns.
- D. Set Air Supply Valve to the TO RUN HYDRAULIC PUMP position. The hydraulic pump will start and supply hydraulic fluid to the Upper Chamber at Port B. Continue running the hydraulic pump while monitoring the Strut. After the Upper Chamber fills with fluid, the Strut will extend and lift the aircraft as fluid is pumped into the strut. Allow the Strut to extend 1 to 2 inches and then set Air Supply valve to the OFF position.
- E. Close Strut Control Valve #2.
- F. Set Main Valve to the STRUT TO WASTE TANK / STRUT SYSTEM HYDRAULIC FLUID TO RESERVOIR position.
- G. Slowly open the Strut Control Valve #2. Excess hydraulic fluid will be vented into the Reservoir from the Upper Chamber. Allow the Upper Chamber to fully compress.
- H. Ensure strut is fully compressed.
- I. Close Strut Control Valve #2.
- J. Set Main Valve to the BYPASS / HYDRAULIC PUMP BYPASS TO RESERVOIR position.
- K. Set Air Supply Valve to the OFF position.
- L. Repeat the above Fill and Vent steps (A thru K) one more time if necessary to insure the hydraulic fluid has displaced all entrapped air or nitrogen in the Upper Chamber.

The Upper Chamber is now serviced with hydraulic fluid.

PROCEDURE 3 (Deflate the Main Chamber, Port A, Service Hose #1):

- A. Verify Strut Control Valves #1 and #2 are closed.
- B. Set Main Valve to the STRUT TO WASTE TANK / STRUT SYSTEM HYDRAULIC FLUID TO RESERVOIR position.



CAUTION!

Operate strut control valve #1 carefully. Adjustment controls strut and aircraft rate of descent.

- C. Slowly open Strut Control Valve #1. Nitrogen and hydraulic fluid will be vented into the Waste Reservoir where they will be separated. Nitrogen will vent out of the reservoir via the exhaust muffler. Fully deflate the Main Chamber.
- D. Set Air Supply Valve to the TO RUN VACUUM PUMP position. This will vent nitrogen out of reservoir and evacuate residual hydraulic fluid from strut.
- E. Close Strut Control Valve #1.
- F. Set Main Valve to the BYPASS / HYDRAULIC PUMP BYPASS TO RESERVOIR position.
- G. Set Air Supply Valve to the OFF position.



PROCEDURE 4 (Fill Main Chamber with Hydraulic Fluid, Port A, Service Hose #1):

- A. Verify Strut Control Valves #1 and #2 are closed.
- B. Set Main Valve to the FLUID TO STRUT / HYDRAULIC FLUID TO STRUT SYSTEM position.
- C. Open Strut Control Valve #1 approximately 2-3 turns.
- D. Set Air Supply Valve to the TO RUN HYDRAULIC PUMP position. The hydraulic pump will start and supply hydraulic fluid to the Main Chamber at Port A. Continue running the hydraulic pump while monitoring the Strut. After the Main Chamber fills with fluid, the Strut will extend and lift the aircraft as fluid is pumped into the Strut. Allow the Strut to extend 2 to 3 inches and then set Air Supply Valve to the OFF position.
- E. Close Strut Control Valve #1.
- F. Set Main Valve to the STRUT TO WASTE TANK / STRUT SYSTEM HYDRAULIC FLUID TO RESERVOIR position.
- G. Slowly open the Strut Control Valve #1. Hydraulic fluid will be vented into the Waste Reservoir from the Main Chamber. Allow the Strut to lower to its full compressed position.
- H. Ensure strut is fully compressed.
- I. Close Strut Control Valve #1.
- J. Set Main Valve to the BYPASS / HYDRAULIC PUMP BYPASS TO RESERVOIR position.
- K. Set Air Supply Valve to the OFF position.
- L. Repeat the above Fill and Vent steps (A thru K) one more time to insure the hydraulic fluid has displaced all entrapped air or nitrogen in the Main Chamber.

The Main Chamber is now serviced with hydraulic fluid.

PROCEDURE 5 (Inflate Upper Chamber with Nitrogen, Port B, Service Hose #2):

- A. Verify the Indicator Rod is free from its stowed position and magnetically engaged to the strut piston magnet.
- B. Verify Strut Control Valves #1 and #2 are closed.
- C. Verify Main Valve is set to the BYPASS / HYDRAULIC PUMP BYPASS TO RESERVOIR position.
- D. Verify that the bottle pressure gauge reads at least 3000 PSIG. This is needed to inflate the Strut Chambers.
- E. Verify Nitrogen Regulator is set to the fully counter-clockwise (OFF) position.
- F. Open Nitrogen Supply Shutoff Valve at least 5 turns.
- G. Slowly open Strut Control Valve #2 (3 to 4 turns) to service the upper chamber.
- H. Press "PSI" (white) button to turn on digital Strut Control Pressure Gauge.
- I. Turn Nitrogen Regulator clockwise to set the appropriate nitrogen pressure required to inflate the Upper Chamber. Nitrogen will begin flowing to the Strut. Slowly continue increasing regulator pressure until Indicator Scale reading on the Indicator Rod equals the Strut Control Pressure Gauge reading. Close Strut Control Valve #2 as soon as pressure is equalized.
- J. Close Nitrogen Supply Shutoff Valve.
- K. Set Main Valve to the STRUT TO WASTE TANK / STRUT SYSTEM HYDRAULIC FLUID TO RESERVOIR position. This will vent pressure from the Strut Unit.
- L. Turn Nitrogen Regulator to the fully counter-clockwise (OFF) position.
- M. Set Main Valve to the BYPASS / HYDRAULIC PUMP BYPASS TO RESERVOIR position.

The Upper Chamber is now serviced with both hydraulic fluid and nitrogen.

PROCEDURE 6 (Inflate Main Chamber with Nitrogen, Port A, Service Hose #1):

- A. Verify Strut Control Valves #1 and #2 are closed.
- B. Verify Main Valve is set to the BYPASS / HYDRAULIC PUMP BYPASS TO RESERVOIR position.
- C. Verify that the bottle pressure gauge reads at least 3000 PSIG. This is needed to inflate the Main Chamber.
- D. Open Nitrogen Supply Shutoff Valve at least 5 turns.
- E. Open Strut Control Valve #1 (3 to 4 turns) to service the Main Chamber.
- F. Press "PSI" (white) button to turn on digital Strut Control Pressure Gauge.
- G. Turn Nitrogen Regulator clockwise to set the appropriate nitrogen pressure required to inflate the Main Chamber. Nitrogen will begin flowing to the Strut. Slowly continue increasing regulator pressure until the Strut extends 3/4 inch to 1 inch from full compressed position. Close Strut Control Valve #1.



CAUTION!

Over-inflation may cause a loss of fluid in the main chamber. Complete re-servicing of the main chamber will be required if this occurs.

- H. Note the Strut Control Pressure Gauge reading. Determine from the Gear Strut Inflation Placard, the correct strut extension for the pressure observed. Open Strut Control Valve #1 and resume inflation until the Strut Control Pressure Gauge reading and Strut Extension agree with the curve on the Gear Strut Inflation Placard.

NOTE: Strut Extension is commonly referred to as Dimension "X".

- I. When the correct Dimension "X" is achieved, close Strut Control Valve #1.



CAUTION!

Do not dump unit nitrogen pressure here by touching the main valve.

The Main Chamber is now serviced with both hydraulic fluid and nitrogen.

PROCEDURE 7 (Verification of Strut Pressure, Ports A and B):

- A. After 15 minutes, press "PSI" (white) button to turn on digital Strut Control Pressure Gauge, open Strut Control Valve #1 and read Strut Control Pressure Gauge again for Main Chamber (Port A). Measure Dimension "X" and verify Strut Extension and the Strut Control Pressure gauge reading agree with the curve on the Gear Strut Inflation Placard.
- B. Close Strut Control Valve #1.
- C. Open Strut Control Valve #2 and read Strut Control Pressure Gauge again for Upper Chamber (Port B). Verify the reading on the Strut Control Pressure Gauge equals the reading on the Indicator Scale on the Indicator Rod of the Upper Chamber.

NOTE: If Strut Control Pressure Gauge turns off, press "PSI" (white) button to restart before taking readings. If the reading on the indicator rod is higher than the pressure gauge reading, add Nitrogen to equalize the two readings.

- D. Close Strut Control Valve #2.
- E. Return the Indicator Rod to its stowed position and tighten to 50 inch-pounds ± 5 inch-pounds.
- F. Close the Strut Service Valve at Port A. 50-70 inch-pounds is recommended.
- G. Close the Strut Service Valve at Port B. 50-70 inch-pounds is recommended.
- H. Turn Nitrogen Regulator to the fully counter-clockwise (OFF) position.
- I. Close Nitrogen Supply Shutoff Valve.
- J. Set the Main Valve to the STRUT TO WASTE TANK / STRUT SYSTEM HYDRAULIC FLUID TO RESERVOIR position.
- K. Open Strut Control Valves #1 and #2 and Verify Strut Control Pressure Gauge reading is "0".
- L. Disconnect Service Hose #1 and #2 from the Strut Service Valves and replace Dust Caps on Strut Service Valves. If Service Unit is equipped with retractable hose reels, retract Service Hoses. Otherwise, re-coil Service Hoses onto hose racks and secure in place with hose straps.
- M. Disconnect air supply hose and nitrogen supply hose to Service Unit and set all Control Panel Valves to off or closed position. Set Main Valve to the BYPASS / HYDRAULIC PUMP BYPASS TO RESERVOIR position.

The Strut is now fully serviced.



MANUFACTURER:

Malabar International
1 Air Cargo Pkwy East
Swanton, Ohio 43558 USA

Telephone: (419) 866-6301 or 800-426-6301
E-mail: sales@malabar.com
Website: www.malabar.com



APPENDIX II

Service Procedure SP8844BSC-2



SERVICE PROCEDURE SP8844BSC-2 TWO SINGLE CHAMBER STRUTS SIMULTANEOUSLY

Reference: 8844B Landing Gear Strut Service Unit



CAUTION!

Aircraft manufacturer's specifications and instructions must be followed. In the event of contradiction between aircraft manufacturer's specifications and Malabar's, aircraft manufacturer's specifications will prevail.

OBJECTIVE:

To properly service the Landing Gear Strut Chambers with hydraulic fluid MIL-PRF-5606 (or approved equivalent) and nitrogen.

GENERAL SERVICE DATA:

The Malabar Model 8844B utilizes the weight of the aircraft during the Strut Service Procedure. All aircraft jacks, stands, docks or other ground equipment must be clear of the aircraft. The procedures include deflating and inflating the aircraft struts which will lower and raise the aircraft structure.

DOCUMENT APPROVAL:

This document must be approved prior to its use for aircraft servicing. The following space is provided to record authorization.

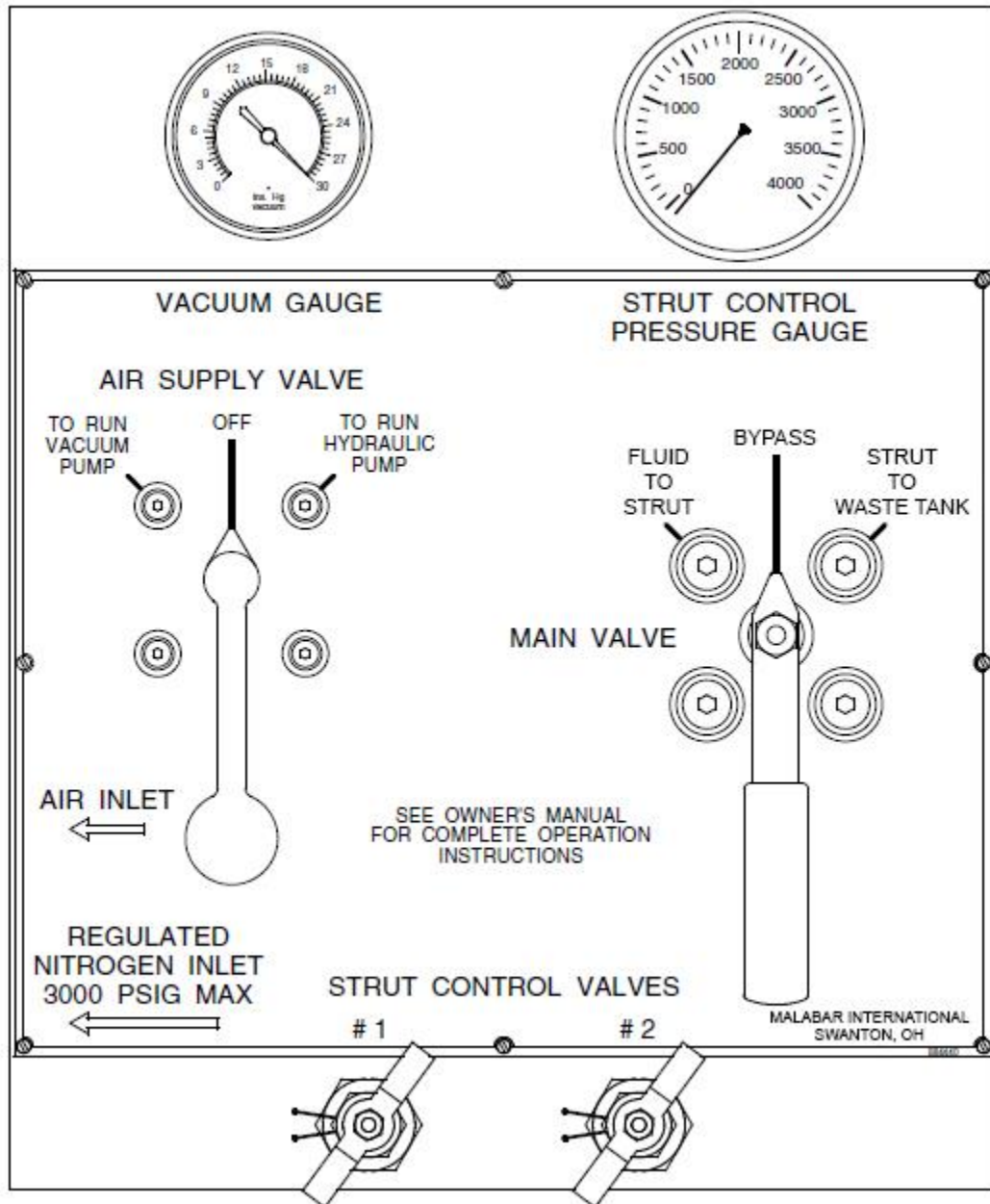

Figure 1 – Control Panel Illustration

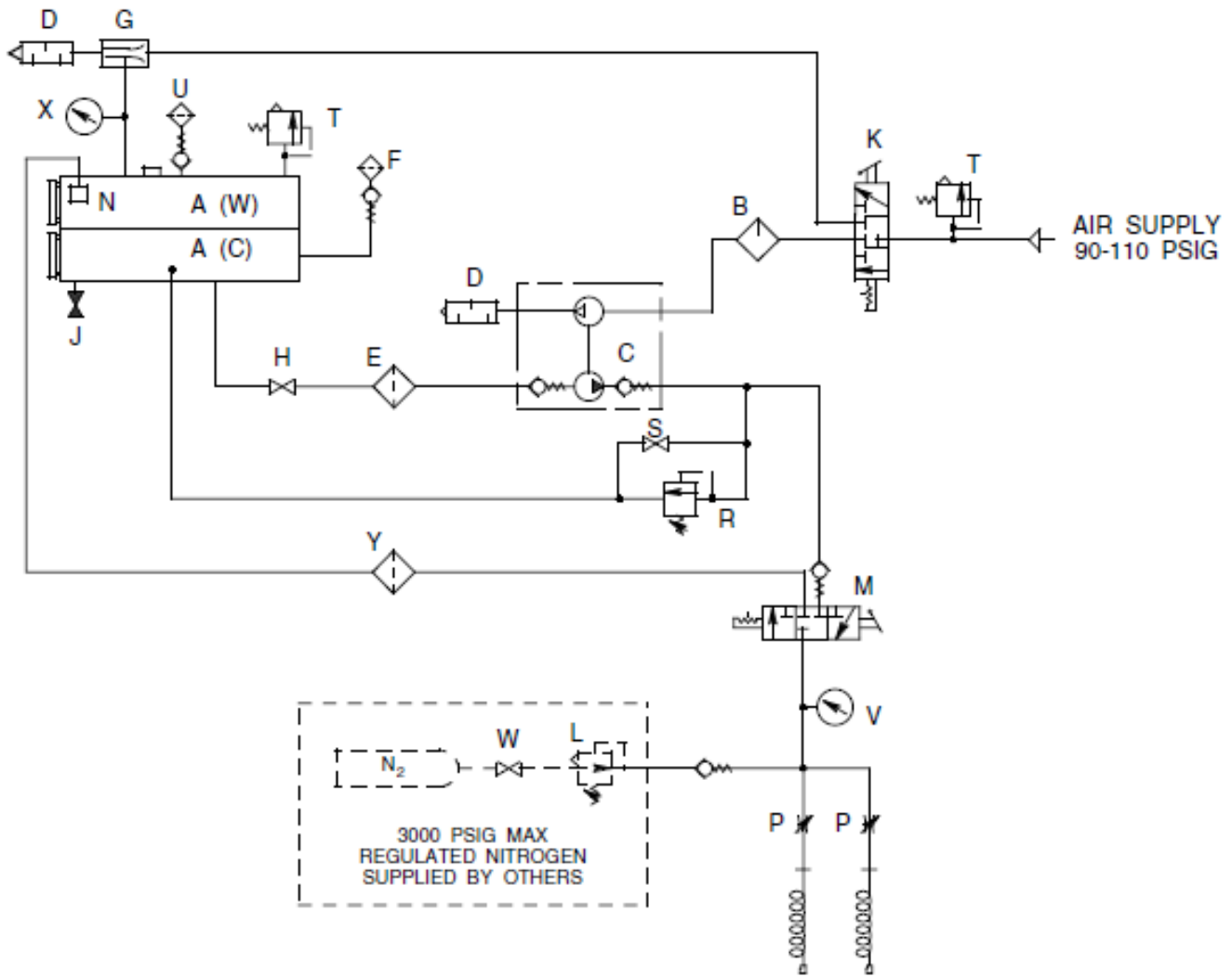

Figure 2 – Pneumatic/Hydraulic Diagram

- | | | | |
|------|------------------------------|---|-------------------------------------|
| A(W) | 7 GALLON WASTE RESERVOIR | M | MAIN VALVE |
| A(C) | 8.5 GALLON CLEAN RESERVOIR | N | NITROGEN DIFFUSER |
| B | AIR LUBRICATOR | P | STRUT CONTROL VALVE |
| C | AIR OPERATED PUMP | R | HYDRAULIC PRESSURE RELIEF VALVE |
| D | MUFFLER | S | BALL VALVE |
| E | PUMP SUCTION FILTER | T | PRESSURE RELIEF VALVE |
| F | DESSICANT AIR FILTER | U | EXHAUST SILENCER/FILTER |
| G | VACUUM PUMP | V | ANALOG STRUT CONTROL PRESSURE GAUGE |
| H | FILTER SERVICE SHUTOFF VALVE | W | NITROGEN SHUTOFF VALVE |
| J | DRAIN COCK VALVE | X | ANALOG VACUUM GAUGE |
| K | AIR SUPPLY VALVE | Y | RETURN FILTER |
| L | NITROGEN REGULATOR | | |



PRIMARY SERVICE PROCEDURES:

1. Deflate the Strut Chambers.
2. Fill the Strut Chambers with hydraulic fluid.
3. Inflate the Strut Chambers with nitrogen.
4. Service Unit shut down.

AIRCRAFT POSITIONING and STRUT INSPECTION:

1. Position the aircraft to ensure the gear struts are in the normal position supporting the weight of the aircraft.
2. Check surrounding area for jacks, docks or other ground equipment and insure equipment is clear of the aircraft structure.
3. Inspect the gear strut service valves and fittings for proper installation and cleanliness.

MALABAR SERVICE UNIT POSITIONING and SERVICE CONNECTIONS:

1. Position the Service Unit clear of the aircraft gear structure with the Service Unit control panel in a position to allow the Service Technician to view both the control panel and the aircraft gear struts.
2. Verify the Service Unit hydraulic fluid lower clean reservoir sight gauge indicates at least 75% full. It is the responsibility of the user to ensure the hydraulic fluid is of the correct type to service the aircraft. A fluid tag is recommended each time the service unit reservoir is filled.
3. Verify all Control Panel valves are in the OFF or closed position.
4. Verify Main Valve is in the BYPASS / HYDRAULIC PUMP BYPASS TO RESERVOIR position.
5. Connect air supply (90-110 psig) to the Air Inlet on the side of the control panel. (If this is the first time the Service Unit is used, the Service Technician will need to install a compatible air service coupling to match the air supply hose fitting).

**CAUTION!**

Use only nitrogen bottle(s) with shutoff valve(s) and regulator(s) serviced to a pressure not to exceed 3600psig.

6. Connect nitrogen supply with shutoff valve(s) closed and regulator(s) off to Regulated Nitrogen Inlet (3000 psig maximum) on the side of the control panel. The minimum recommended initial nitrogen bottle pressure should be at least 3000 PSIG. (If this is the first time the Service Unit is used, the Service Technician will need to install a compatible nitrogen service coupling to match the nitrogen supply hose fitting).

**CAUTION!**

Ensure that the strut service valves are lockwired inplace before proceeding. Serious injury may result if the strut service valves are loosened with the strut under pressure.

7. Connecting Service Unit hoses to the Struts:
 - a. Remove Dust Caps from the Strut Air Service Valves.

NOTE: 75-100 inch-pounds is recommended when installing the Service Hose Chucks to the Strut Air Service Valves; do not exceed 100 inch pounds.

- b. If Service Unit is not equipped with retractable hose reels, unwind hoses from hose racks and connect Service Hose #1 to the Air Service Valve located near the top of the Left Strut. Connect Service Hose #2 to the Air Service Valve located near the top of the Right Strut.
 - c. If Service Unit is equipped with retractable hose reels, pull out hoses and connect Hose #1 to the Air Service Valve located near the top of the Left Strut. Connect Service Hose #2 to the Air Service Valve located near the top of the Right Strut.
8. Slowly open the Left Strut Air Service Valve (utilizing an open end wrench) by rotating the swivel nut counter-clockwise. Make sure that the lockwired Valve Body remains tight by holding in place with a wrench. This will ensure that no serious injury will occur. This procedure will pressurize the #1 Service Hose.
9. Repeat step 8 for the Right Strut. This will pressurize the #2 Service Hose.

The Aircraft Struts and the Service Unit are now ready for the following service procedures.

PROCEDURE 1 (Deflate the Strut Chambers):

- A. Verify Strut Control Valves #1 and #2 are closed.
- B. Set Main Valve to the STRUT TO WASTE TANK / STRUT SYSTEM HYDRAULIC FLUID TO RESERVOIR position.



CAUTION!

Operate strut control valves #1 and #2 carefully. Adjustment controls strut and aircraft rate of descent.

- C. Slowly open Strut Control Valves #1 and #2. Nitrogen and hydraulic fluid will be vented into the Waste Reservoir where they will be separated. Nitrogen will vent out of the reservoir via the exhaust muffler. Fully deflate the Strut Chambers.
- D. Set Air Supply Valve to the TO RUN VACUUM PUMP position. This will vent nitrogen out of reservoir and evacuate residual hydraulic fluid from strut.
- E. Close Strut Control Valves #1 and #2.
- F. Set Main Valve to the BYPASS / HYDRAULIC PUMP BYPASS TO RESERVOIR position.
- G. Set Air Supply Valve to the OFF position.

PROCEDURE 2 (Fill the Strut Chambers with Hydraulic Fluid):

- A. Verify Strut Control Valves #1 and #2 are closed.
- B. Set Main Valve to the FLUID TO STRUT / HYDRAULIC FLUID TO STRUT SYSTEM position.
- C. Open Strut Control Valves #1 and #2 approximately 2-3 turns.
- D. Set Air Supply Valve to the TO RUN HYDRAULIC PUMP position. The hydraulic pump will start and supply hydraulic fluid to the Strut Chambers. Continue running the hydraulic pump while monitoring the Struts. After the Strut Chambers are filled with fluid, the Struts will extend and lift the aircraft as fluid is pumped into the Struts. Allow the Struts to extend 2 to 3 inches and then set Air Supply Valve to the OFF position.
- E. Close Strut Control Valves #1 and #2.
- F. Set Main Valve to the STRUT TO WASTE TANK / STRUT SYSTEM HYDRAULIC FLUID TO RESERVOIR position.
- G. Slowly open Strut Control Valves #1 and #2. Hydraulic fluid will be vented into the Reservoir from the Strut Chambers. Allow the Struts to lower to their full compressed position.
- H. Ensure struts are fully compressed.
- I. Close Strut Control Valves #1 and #2.
- J. Set Main Valve to the BYPASS / HYDRAULIC PUMP BYPASS TO RESERVOIR position.
- K. Set Air Supply Valve to the OFF position.
- L. Repeat the above Fill and Vent steps (A thru K) one more time to insure the hydraulic fluid has displaced all entrapped air or nitrogen in the Strut Chambers.

The Strut Chambers are now serviced with hydraulic fluid.

PROCEDURE 3 (Inflate the Strut Chambers with Nitrogen):

- A. Verify Strut Control Valves #1 and #2 are closed.
- B. Verify Main Valve is set to the BYPASS/HYDRAULIC PUMP BYPASS TO RESERVOIR position.
- C. Verify that the bottle pressure gauge reads at least 3000 PSIG. This is needed to inflate the StrutChambers
- D. Verify Nitrogen Regulator is set to the fully counter-clockwise (OFF) position.
- E. Open Nitrogen Supply Shutoff Valve at least 5 turns.
- F. Open Strut Control Valve #1 (3 to 4 turns) to service the Left Strut Chamber.
- G. Press "PSI" (white) button to turn on digital Strut Control Pressure Gauge.
- H. Turn Nitrogen Regulator clockwise to set the appropriate nitrogen pressure required to inflate the Left Strut Chamber. Nitrogen will begin flowing to the Strut. Slowly continue increasing regulator pressure until the Strut extends 3/4 inch to 1 inch from full compressed position. Close Strut Control Valve #1.



CAUTION!

Over-inflation may cause a loss of fluid in the strut chamber. Complete re-servicing of the strut chamber will be required if this occurs.

- I. Note the Strut Control Pressure Gauge reading. Determine from the Gear Strut Inflation Placard, the correct strut extension for the pressure observed. Open Strut Control Valve #1 and resume inflation until the Strut Control Pressure Gauge reading and Strut Extension agree with the curve on the Gear Strut Inflation Placard.

NOTE: Strut Extension is commonly referred to as Dimension "X".

- J. When the correct Dimension "X" is achieved, close Strut Control Valve #1.
- K. Turn Nitrogen Regulator to the full counter-clockwise (OFF) position.
- L. Open Strut Control Valve #2 (3 to 4 turns) to service the Right Strut Chamber.
- M. Turn Nitrogen Regulator clockwise to set the appropriate nitrogen pressure required to inflate the Right Strut Chamber. Nitrogen will begin flowing to the Strut. Slowly continue increasing regulator pressure until the Strut extends 3/4 inch to 1 inch from full compressed position. Close strut Control Valve #2.



CAUTION!

Over-inflation may cause a loss of fluid in the strut chamber. Complete re-servicing of the strut chamber will be required if this occurs.

- N. Note the Strut Control Pressure Gauge reading. Determine from the Gear Strut Inflation Placard, the correct strut extension for the pressure observed. Open Strut Control Valve #2 and resume inflation until the Strut Control Pressure Gauge reading and Strut Extension agree with the curve on the Gear Strut Inflation Placard.

NOTE: If Strut Control Pressure Gauge turns off, press "PSI" (white) button to restart before taking readings. Strut Extension is commonly referred to as Dimension "X".

- O. When the correct Dimension "X" is achieved, close Strut Control Valve #2.
- P. Turn Nitrogen Regulator to the full counter-clockwise (OFF) position.
- Q. Close Nitrogen Supply Shutoff Valve.

The Strut Chambers are now serviced with both hydraulic fluid and nitrogen.



PROCEDURE 4 (Unit shut down):

- A. Close the Strut Air Service Valves. 50-70 inch-pounds is recommended.
- B. Close Strut Control Valves #1 and #2.
- C. Set the Main Valve to the STRUT TO WASTE TANK / STRUT SYSTEM HYDRAULIC FLUID TO RESERVOIR position.
- D. Slowly open Strut Control Valves #1 and #2. Verify Strut Control Pressure Gauge reading is "0".
- E. Disconnect Service Hoses #1 and #2 from the Strut Air Service Valves. Replace Dust Caps on Strut Air Service Valves. If Service Unit is equipped with retractable hose reels, retract Service Hoses. Otherwise, re-coil Service Hoses on to hose racks and secure in place with hose straps.
- F. Disconnect air supply hose and nitrogen supply hose to Service Unit and set all Control Panel Valves to off or closed position. Set Main Valve to the HYDRAULIC PUMP BYPASS TO RESERVOIR position.

The Struts are now fully serviced.

MANUFACTURER:

Malabar International
1 Air Cargo Pkwy East
Swanton, Ohio 43558 USA

Telephone: (419) 866-6301 or 800-426-6301
E-mail: sales@malabar.com
Website: www.malabar.com