

Date: March 12, 2009

# **MALABAR**

**INTERNATIONAL**

***AIRCRAFT MAINTENANCE & SUPPORT EQUIPMENT***

***OWNER'S MANUAL FOR MALABAR MODEL***

## **150-24**

***1 QUART O-C FLUID GUN DISPENSER***

***READ  
AND  
SAVE***

**THIS  
INSTRUCTION  
MANUAL**

- \* GENERAL DESCRIPTION
- \* OPERATION
- \* SERVICE
- \* PARTS BREAKDOWN

For Service & Spare  
Parts, Please Contact:

Malabar International  
220 W. Los Angeles Avenue  
Simi Valley, California 93065  
Phone: (805) 581-0116  
Fax: (805) 584-1624  
E-mail: [sales@malabar.com](mailto:sales@malabar.com)  
Web site: <http://www.malabar.com>

***OVER 65 YEARS OF SERVICE & EXPERIENCE***

## GENERAL DESCRIPTION, OPERATION, SERVICE AND PARTS BREAKDOWN

# **MALABAR MODEL 150-24 1 QUART O-C FLUID GUN DISPENSER**

**CAUTION: AIRCRAFT MANUFACTURER'S SPECIFICATION AND INSTRUCTIONS MUST BE FOLLOWED IN THE EVENT OF CONTRADICTION BETWEEN AIRCRAFT MANUFACTURER'S SPECIFICATIONS AND MALABAR'S AIRCRAFT MANUFACTURER'S SPECIFICATIONS WILL PREVAIL.**

### **SPECIFICATIONS:**

Fluid-----	ENGINE AND IDG OIL
Fluid Capacity-----	1 quart (.95 liters)
Pump Outlet Pressure-----	80 psig (551 kg/sq cm)
Volume Per Stroke-----	2 cubic inches (33 cc)
Hose Length-----	74 inches (1880 mm)
Net Weight (empty)-----	6.5 lbs (2.9 kg)
Filter Rating-----	3 micron nominal

### **GENERAL DESCRIPTION:**

The Malabar Model 150-24 is a one quart original container fluid gun dispenser used to service various commercial aircraft. The O-C Fluid Gun Dispenser consists of a hand pump assembly, filter assembly and a fluid delivery hose with a coupling.

### **PREPARATION FOR USE:**

1. Attach the hose assembly to the gun. Avoid over tightening the swivel nut.
2. The two latches attached to the clamp bars may require adjustment. Loosen the four screws, washers and self-locking nuts and adjust latches to fit oil can before tightening screws.

### **OPERATION:**

1. Slide piercer rod fully up and latch oil can to gun. Check the fluid specification and brand for compatibility with the aircraft system.
2. Strike piercer handle firmly using palm of hand or rubber mallet to drive piercer through top of oil can. Assure piercer is firmly placed in oil can.

**CAUTION: TO PREVENT DAMAGE TO THE PIERCER ROD OR PIERCER HANDLE, DO NOT USE ANY TOOL OTHER THAN A RUBBER Mallet.**

3. Open the bleed screw on the sight gage (one turn only) and carefully pump the gun to prime and eliminate any air bubbles. Close bleed screw.

**CAUTION: AIR PUMPED IN WITH OIL MAY CAUSE FALSE LEVEL READINGS IN AIRCRAFT SYSTEMS AS THE AIR EVENTUALLY BUBBLES OFF AND THE LEVEL DROPS.**

4. Remove dust plug from hose end coupling and connect hose end coupling to the aircraft service

point.

5. Use full steady pump strokes when operating pump assembly during replenishing. Stop pumping oil when can is empty or air bubbles are detected in sight gage. Reprime gun when changing cans.
6. When finished, disconnect the hose end coupling from the aircraft service point. Replace the dust plug and store the gun in a dry dust free location.
7. When gun is stored, it is advisable to keep oil can latched to the gun to prevent contamination and oil mess.

## **SERVICING:**

The frequency of filter change depends on operating conditions. Generally, changes should be made every 3-4 months or sooner if more than normal resistance is felt on the pumping stroke at low pressure. Refer to figure 1A, item 43 to change filter element.

## **REPAIR AND REPLACEMENT:**

No definite time schedule can be established for the overhaul of the O-C fluid gun dispenser assembly for the replacement of the various moving parts. The number of times the pump assembly is operated materially affects the life of the working parts. The moving piston seals (figure 1A, item 20) and piercer rod seals (figure 1A, item 22) are normally the first to wear. This is usually indicated by leakage of fluid past the piston rod (figure 1A, item 2) or the piercer rod (figure 1A, item 12). It is advisable to change piston seals (figure 1A, item 20) and piercer rod seals (figure 1A, item 22) immediately if leakage is discovered. Regardless of apparent condition, replace all parts marked with (◆). A repair parts kit (P/N 150-4PK) which contains all of the parts marked with (◆) is available and recommended to keep on hand at your facility. Coat all o-rings with petroleum jelly prior to assembly. Clean all metal parts with solvent and dry with compressed air. Lubricate all threads. Refer to sheet 6 for the complete list of parts contained in the repair parts kit.

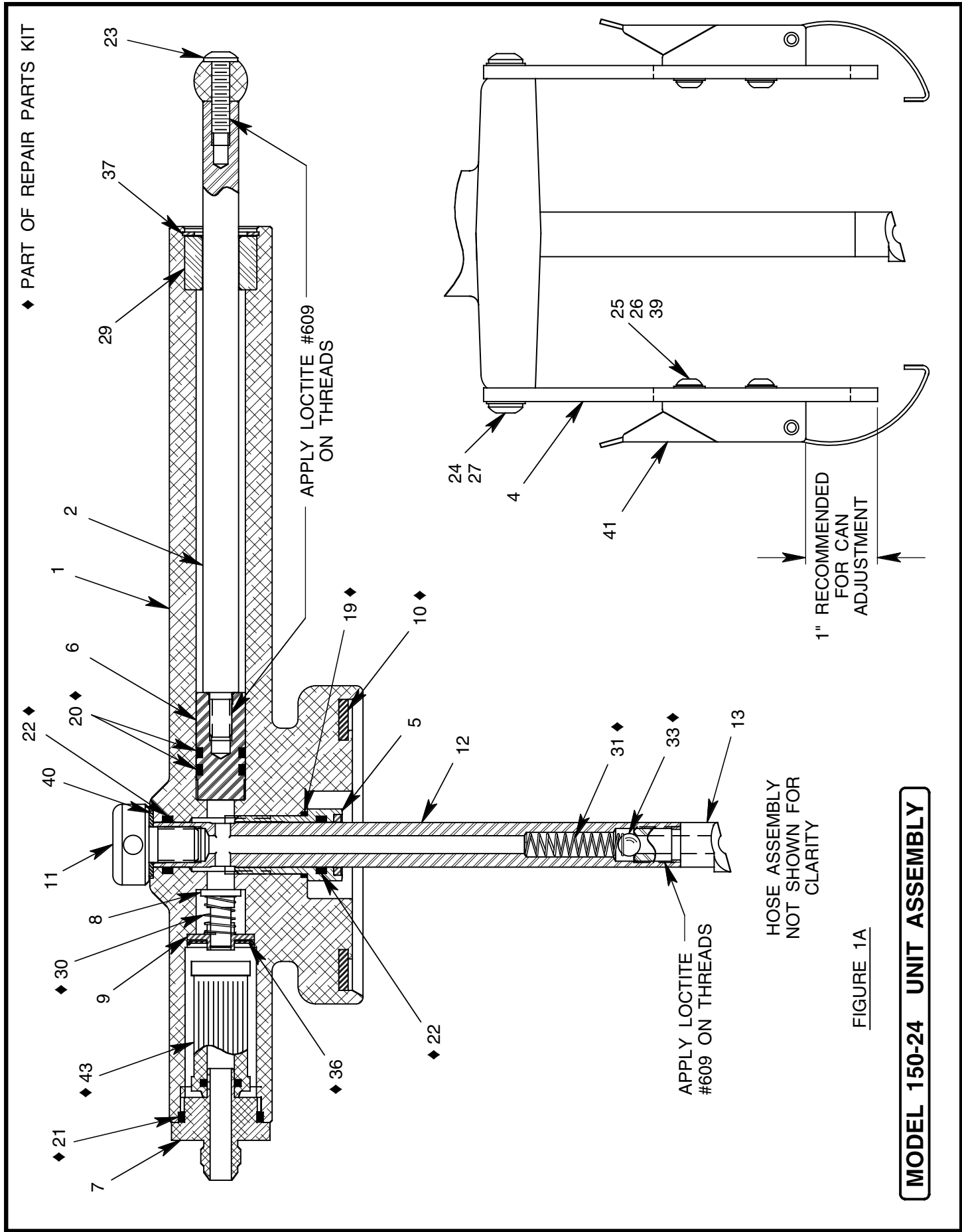

◆ PART OF REPAIR PARTS KIT

APPLY LOCTITE #609 ON THREADS

APPLY LOCTITE #609 ON THREADS

HOSE ASSEMBLY NOT SHOWN FOR CLARITY

1" RECOMMENDED FOR CAN ADJUSTMENT

FIGURE 1A

**MODEL 150-24 UNIT ASSEMBLY**

◆ PART OF REPAIR PARTS KIT

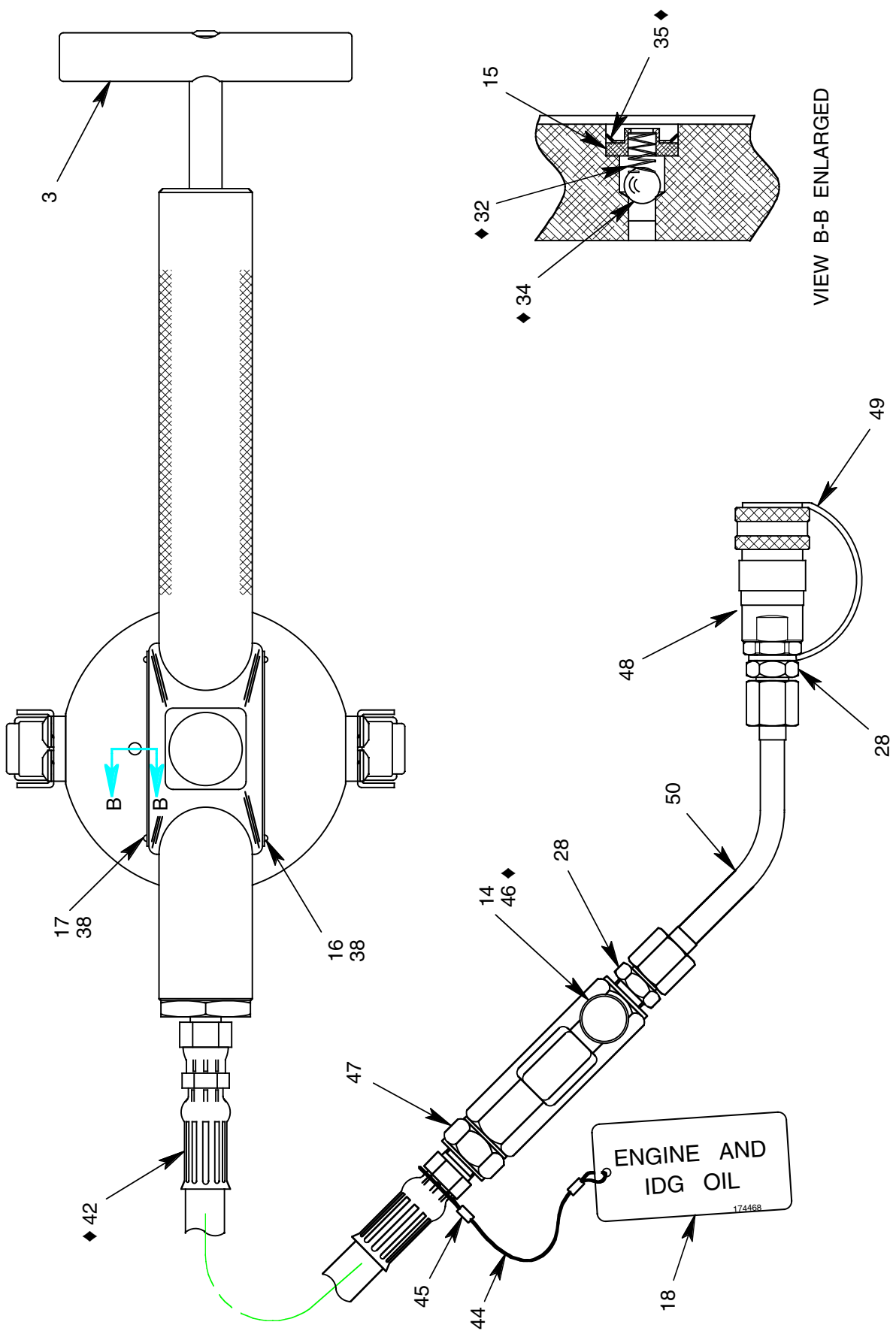

FIGURE 1B

**MODEL 150-24 UNIT ASSEMBLY**

**MODEL 150-24 UNIT ASSEMBLY PARTS LIST**

NO.	QTY	PART NO.	PART NAME
1	1	*174493-1	PUMP BODY MACHINE
2	1	174405	PISTON ROD
3	1	174406	HANDLE
4	2	174407	CLAMP BAR
5	1	174459	BEARING BOLT ASSEMBLY
6	1	174411	PISTON
7	1	174412	ADAPTER FITTING
8	1	174413	VALVE POPPET
9	1	174414	POPPET GUIDE
10	1	174415	CAN SEAL
11	1	174416	PIERCER HANDLE
12	1	174460	PIERCER ROD
13	1	174461	PIERCER
14	1	174419	BLEED SCREW
15	1	174420	SPRING SUPPORT
16	1	174421	PLACARD
17	1	174467	PLACARD, ENGINE AND IDG OIL
18	1	174468	PLACARD, ENGINE AND IDG OIL
19	1	55925-019	O-RING
20	2	55925-112	O-RING
21	1	55925-120	O-RING
22	2	55925-114	O-RING
23	1	326-009	BHCS, 1/4-20 x 1" LG
24	4	326-010	BHCS, 1/4-20 x 5/8 LG
25	4	326-020	BHCS, 10-24 x 1/2 LG
26	4	355-025	HEX LOCKNUT, 10-24
27	4	363-001	SPLIT LOCKWASHER, 1/4
28	2	721-004	CONNECTOR, 3/8 37° x 1/4 MPT
29	1	410-017	BRONZE BEARING
30	1	495-035	SPRING
31	1	495-036	SPRING
32	1	495-037	SPRING
33	1	412-002	BALL, CHROME, 5/16 DIA
34	1	412-004	BALL, CHROME, 1/4 DIA
35	1	380-005	RETAINING RING, PUSH ON
36	1	380-004	RETAINING RING, PUSH ON
37	1	55926-100	RETAINING RING, PUSH ON
38	8	393-004	DRIVE SCREW, #2 x 3/16 LG
39	4	362-045	FLAT WASHER, #10
40	1	369-002	NYLON FLAT WASHER
41	2	491-056	LATCH
42	1	174445	HOSE ASSEMBLY
43	1	481-005	FILTER ELEMENT
44	1	491-027	CABLE, .048 DIA x 6" LG
45	2	491-028	SLEEVE CRIMP
46	1	55925-904	O-RING
47	1	174425	SIGHT GAGE
48	1	736-001	COUPLING
49	1	736-120	DUST PLUG
50	1	PF55817	ELBOW ASSEMBLY

### 150-4PK REPAIR PARTS KIT

QTY	PART NO.	PART NAME
1	174445	HOSE ASSEMBLY
1	481-005	FILTER ELEMENT
1	174415	CAN SEAL
1	55925-904	O-RING
2	55925-114	O-RING
1	55925-120	O-RING
2	55925-112	O-RING
1	55925-019	O-RING
1	495-035	SPRING
1	495-036	SPRING
1	495-037	SPRING
1	412-002	BALL, CHROME, 5/16 DIA
1	412-004	BALL, CHROME, 1/4 DIA
1	380-005	RETAINING RING, PUSH ON
1	380-004	RETAINING RING, PUSH ON
1	150-4PKDOC	REPAIR PARTS KIT LIST